

PRECALCULUS

A RIGHT TRIANGLE APPROACH

FOURTH EDITION

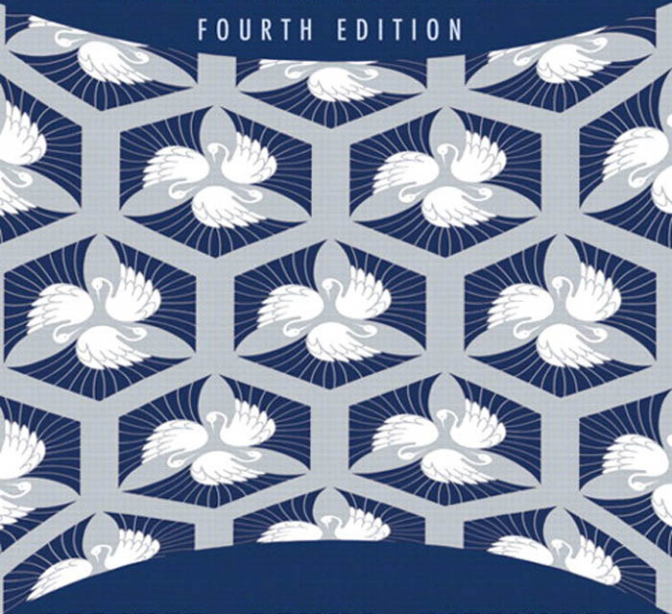

BEECHER PENNA BITTINGER

Precalculus

A Right Triangle Approach

4th

EDITION

Judith A. Beecher

Indiana University Purdue University Indianapolis

Judith A. Penna

Indiana University Purdue University Indianapolis

Marvin L. Bittinger

Indiana University Purdue University Indianapolis

Addison-Wesley

Boston Columbus Indianapolis
New York San Francisco Upper Saddle River
Amsterdam Cape Town Dubai London
Madrid Milan Munich Paris Montréal Toronto
Delhi Mexico City São Paulo Sydney
Hong Kong Seoul Singapore Taipei Tokyo

<i>Editor-in-Chief</i>	Anne Kelly
<i>Executive Content Editor</i>	Christine O'Brien
<i>Senior Content Editor</i>	Joanne Dill
<i>Editorial Assistant</i>	Brendan Berger
<i>Senior Managing Editor</i>	Karen Wernholm
<i>Senior Production Project Manager</i>	Kathleen A. Manley
<i>Design Manager</i>	Andrea Nix
<i>Senior Design Specialist</i>	Heather Scott
<i>Digital Assets Manager</i>	Marianne Groth
<i>Supplements Production Coordinator</i>	Kerri McQueen
<i>Media Producer</i>	Shana Siegmund
<i>Software Development</i>	Kristina Evans, MathXL; Mary Durnwald, TestGen
<i>Executive Marketing Manager</i>	Roxanne McCarley
<i>Marketing Manager</i>	Peggy Sue Lucas
<i>Marketing Assistant</i>	Katherine Minton
<i>Senior Author Support/Technology Specialist</i>	Joe Vetere
<i>Senior Manufacturing Buyer</i>	Carol Melville
<i>Senior Media Buyer</i>	Ginny Michaud
<i>Design, Art Editing, and Photo Research</i>	The Davis Group, Inc.
<i>Editorial Coordination</i>	Martha Morong/Quadrata, Inc.
<i>Production Coordination</i>	Sally Lifland/Lifland et al., Bookmakers
<i>Composition</i>	PreMediaGlobal
<i>Illustrations</i>	Network Graphics, William Melvin, and PreMediaGlobal
<i>Cover Image</i>	Shutterstock/©medvedeff

Photo credits can be found on p. 989.

Many of the designations used by manufacturers and sellers to distinguish their products are claimed as trademarks. Where those designations appear in this book, and Pearson was aware of a trademark claim, the designations have been printed in initial caps or all caps.

Library of Congress Cataloging-in-Publication Data

Beecher, Judith A.

Precalculus / Judith A. Beecher, Judith A. Penna, Marvin L. Bittinger.—4th ed.

p. cm.

ISBN-13: 978-0-321-69397-6

ISBN-10: 0-321-69397-3

I. Algebra—Textbooks. 2. Trigonometry—Textbooks. I. Penna, Judith A.

II. Bittinger, Marvin L. III. Title.

QA152.3.B45 2012

512'.13—dc22

2010034969

Copyright © 2012, 2008, 2005, 2002 Pearson Education, Inc. All rights reserved. No part of this publication may be reproduced, stored in a retrieval system, or transmitted, in any form or by any means, electronic, mechanical, photocopying, recording, or otherwise, without the prior written permission of the publisher. Printed in the United States of America. For information on obtaining permission for use of material in this work, please submit a written request to Pearson Education, Inc., Rights and Contracts Department, 501 Boylston Street, Suite 900, Boston, MA 02116, fax your request to 617-671-3447, or e-mail at <http://www.pearsoned.com/legal/permissions.htm>.

1 2 3 4 5 6 7 8 9 10—DOW—14 13 12 11 10

Addison-Wesley
is a imprint of



www.pearsonhighered.com

ISBN-13: 978-0-321-69397-6

ISBN-10: 0-321-69397-3

Contents

Preface xi

R

Basic Concepts of Algebra

1

- R.1 The Real-Number System** 2
Real Numbers / Interval Notation / Properties of the Real Numbers / Absolute Value
- R.2 Integer Exponents, Scientific Notation, and Order of Operations** 8
Integers as Exponents / Scientific Notation / Order of Operations
- R.3 Addition, Subtraction, and Multiplication of Polynomials** 17
Polynomials / Addition and Subtraction / Multiplication
- R.4 Factoring** 22
Terms with Common Factors / Factoring by Grouping / Trinomials of the Type $x^2 + bx + c$ / Trinomials of the Type $ax^2 + bx + c, a \neq 1$ / Special Factorizations
- R.5 The Basics of Equation Solving** 31
Linear Equations and Quadratic Equations / Formulas
- R.6 Rational Expressions** 36
The Domain of a Rational Expression / Simplifying, Multiplying, and Dividing Rational Expressions / Adding and Subtracting Rational Expressions / Complex Rational Expressions
- R.7 Radical Notation and Rational Exponents** 45
Simplifying Radical Expressions / An Application / Rationalizing Denominators or Numerators / Rational Exponents
- Study Guide 53
Review Exercises 54
Chapter Test 56

1

Graphs, Functions, and Models

59

- 1.1 Introduction to Graphing** 60
Graphs / Solutions of Equations / Graphs of Equations / The Distance Formula / Midpoints of Segments / Circles
- VISUALIZING THE GRAPH 71
- 1.2 Functions and Graphs** 75
Functions / Notation for Functions / Graphs of Functions / Finding Domains of Functions / Visualizing Domain and Range / Applications of Functions

- 1.3 Linear Functions, Slope, and Applications** 91
 Linear Functions / The Linear Function $f(x) = mx + b$ and Slope /
 Applications of Slope / Slope–Intercept Equations of Lines /
 Graphing $f(x) = mx + b$ Using m and b / Applications of Linear Functions
VISUALIZING THE GRAPH 102
MID-CHAPTER MIXED REVIEW 107
- 1.4 Equations of Lines and Modeling** 109
 Slope–Intercept Equations of Lines / Point–Slope Equations of Lines /
 Parallel Lines / Perpendicular Lines / Mathematical Models / Curve Fitting
- 1.5 Linear Equations, Functions, Zeros, and Applications** 121
 Linear Equations / Applications Using Linear Models / Zeros of Linear Functions
- 1.6 Solving Linear Inequalities** 138
 Linear Inequalities / Compound Inequalities / An Application
Study Guide 144
Review Exercises 150
Chapter Test 154

2

More on Functions**157**

- 2.1 Increasing, Decreasing, and Piecewise Functions; Applications** 158
 Increasing, Decreasing, and Constant Functions / Relative Maximum
 and Minimum Values / Applications of Functions / Functions
 Defined Piecewise
- 2.2 The Algebra of Functions** 171
 The Algebra of Functions: Sums, Differences, Products, and Quotients /
 Difference Quotients
- 2.3 The Composition of Functions** 179
 The Composition of Functions / Decomposing a Function as a Composition
MID-CHAPTER MIXED REVIEW 187
- 2.4 Symmetry and Transformations** 189
 Symmetry / Even Functions and Odd Functions / Transformations of Functions /
 Vertical Translations and Horizontal Translations / Reflections / Vertical and
 Horizontal Stretchings and Shrinkings
VISUALIZING THE GRAPH 205
- 2.5 Variation and Applications** 211
 Direct Variation / Inverse Variation / Combined Variation
Study Guide 220
Review Exercises 227
Chapter Test 231

3

Quadratic Functions and Equations; Inequalities**233**

- 3.1 The Complex Numbers 234**
The Complex-Number System / Addition and Subtraction /
Multiplication / Conjugates and Division
- 3.2 Quadratic Equations, Functions, Zeros, and Models 241**
Quadratic Equations and Quadratic Functions / Completing the Square /
Using the Quadratic Formula / The Discriminant / Equations Reducible to
Quadratic / Applications
- 3.3 Analyzing Graphs of Quadratic Functions 257**
Graphing Quadratic Functions of the Type $f(x) = a(x - h)^2 + k$ /
Graphing Quadratic Functions of the Type $f(x) = ax^2 + bx + c, a \neq 0$ /
Applications
VISUALIZING THE GRAPH 266
MID-CHAPTER MIXED REVIEW 270
- 3.4 Solving Rational Equations and Radical Equations 272**
Rational Equations / Radical Equations
- 3.5 Solving Equations and Inequalities with Absolute Value 280**
Equations with Absolute Value / Inequalities with Absolute Value
Study Guide 285
Review Exercises 289
Chapter Test 293

4

Polynomial Functions and Rational Functions**295**

- 4.1 Polynomial Functions and Models 296**
The Leading-Term Test / Finding Zeros of Factored Polynomial Functions /
Polynomial Models
- 4.2 Graphing Polynomial Functions 309**
Graphing Polynomial Functions / The Intermediate Value Theorem
VISUALIZING THE GRAPH 317
- 4.3 Polynomial Division; The Remainder Theorem
and the Factor Theorem 320**
Division and Factors / The Remainder Theorem and Synthetic Division /
Finding Factors of Polynomials
MID-CHAPTER MIXED REVIEW 328
- 4.4 Theorems about Zeros of Polynomial Functions 330**
The Fundamental Theorem of Algebra / Finding Polynomials with
Given Zeros / Zeros of Polynomial Functions with Real Coefficients /
Rational Coefficients / Integer Coefficients and the Rational Zeros Theorem /
Descartes' Rule of Signs

- 4.5 Rational Functions** 340
 The Domain of a Rational Function / Asymptotes / Applications
VISUALIZING THE GRAPH 356
- 4.6 Polynomial Inequalities and Rational Inequalities** 360
 Polynomial Inequalities / Rational Inequalities
 Study Guide 372
 Review Exercises 381
 Chapter Test 385

5**Exponential Functions and Logarithmic Functions 387**

- 5.1 Inverse Functions** 388
 Inverses / Inverses and One-to-One Functions / Finding Formulas for Inverses /
 Inverse Functions and Composition / Restricting a Domain
- 5.2 Exponential Functions and Graphs** 400
 Graphing Exponential Functions / Applications / The Number e /
 Graphs of Exponential Functions, Base e
- 5.3 Logarithmic Functions and Graphs** 413
 Logarithmic Functions / Finding Certain Logarithms / Converting Between Exponential
 Equations and Logarithmic Equations / Finding Logarithms on a Calculator / Natural
 Logarithms / Changing Logarithmic Bases / Graphs of Logarithmic Functions /
 Applications
VISUALIZING THE GRAPH 425
MID-CHAPTER MIXED REVIEW 429
- 5.4 Properties of Logarithmic Functions** 430
 Logarithms of Products / Logarithms of Powers / Logarithms of Quotients /
 Applying the Properties / Simplifying Expressions of the Type $\log_a a^x$ and $a^{\log_a x}$
- 5.5 Solving Exponential Equations and Logarithmic Equations** 439
 Solving Exponential Equations / Solving Logarithmic Equations
- 5.6 Applications and Models: Growth and Decay; Compound Interest** 450
 Population Growth / Interest Compounded Continuously / Models of
 Limited Growth / Exponential Decay
 Study Guide 465
 Review Exercises 471
 Chapter Test 475

6**The Trigonometric Functions 477**

- 6.1 Trigonometric Functions of Acute Angles** 478
 The Trigonometric Ratios / The Six Functions Related /
 Function Values of 30° , 45° , and 60° / Function Values of Any
 Acute Angle / Cofunctions and Complements

- 6.2 Applications of Right Triangles** 490
Solving Right Triangles / Applications
- 6.3 Trigonometric Functions of Any Angle** 503
Angles, Rotations, and Degree Measure / Trigonometric Functions of Angles or Rotations / The Six Functions Related / Terminal Side on an Axis / Reference Angles: 30° , 45° , and 60° / Function Values for Any Angle
MID-CHAPTER MIXED REVIEW 519
- 6.4 Radians, Arc Length, and Angular Speed** 520
Distances on the Unit Circle / Radian Measure / Arc Length and Central Angles / Linear Speed and Angular Speed
- 6.5 Circular Functions: Graphs and Properties** 536
Reflections on the Unit Circle / Finding Function Values / Graphs of the Sine and Cosine Functions / Graphs of the Tangent, Cotangent, Cosecant, and Secant Functions
- 6.6 Graphs of Transformed Sine and Cosine Functions** 551
Variations of Basic Graphs / Graphs of Sums: Addition of Ordinates / Damped Oscillation: Multiplication of Ordinates
VISUALIZING THE GRAPH 565
Study Guide 569
Review Exercises 578
Chapter Test 581

7

Trigonometric Identities, Inverse Functions, and Equations

583

- 7.1 Identities: Pythagorean and Sum and Difference** 584
Pythagorean Identities / Simplifying Trigonometric Expressions / Sum and Difference Identities
- 7.2 Identities: Cofunction, Double-Angle, and Half-Angle** 597
Cofunction Identities / Double-Angle Identities / Half-Angle Identities
- 7.3 Proving Trigonometric Identities** 605
The Logic of Proving Identities / Proving Identities / Product-to-Sum and Sum-to-Product Identities
MID-CHAPTER MIXED REVIEW 613
- 7.4 Inverses of the Trigonometric Functions** 614
Restricting Ranges to Define Inverse Functions / Composition of Trigonometric Functions and Their Inverses
- 7.5 Solving Trigonometric Equations** 625
VISUALIZING THE GRAPH 635
Study Guide 639
Review Exercises 645
Chapter Test 648

8

Applications of Trigonometry

649

- 8.1 The Law of Sines** 650
Solving Oblique Triangles / The Law of Sines / Solving Triangles (AAS and ASA) / Solving Triangles (SSA) / The Area of a Triangle
- 8.2 The Law of Cosines** 663
The Law of Cosines / Solving Triangles (SAS) / Solving Triangles (SSS)
- 8.3 Complex Numbers: Trigonometric Form** 673
Graphical Representation / Trigonometric Notation for Complex Numbers / Multiplication and Division with Trigonometric Notation / Powers of Complex Numbers / Roots of Complex Numbers
- MID-CHAPTER MIXED REVIEW 684
- 8.4 Polar Coordinates and Graphs** 686
Polar Coordinates / Polar Equations and Rectangular Equations / Graphing Polar Equations
- VISUALIZING THE GRAPH 694
- 8.5 Vectors and Applications** 697
Vectors / Vector Addition / Applications / Components
- 8.6 Vector Operations** 705
Position Vectors / Operations on Vectors / Unit Vectors / Direction Angles / Angle Between Vectors / Forces in Equilibrium
- Study Guide 720
Review Exercises 731
Chapter Test 735

9

Systems of Equations and Matrices

737

- 9.1 Systems of Equations in Two Variables** 738
Solving Systems of Equations Graphically / The Substitution Method / The Elimination Method / Applications
- VISUALIZING THE GRAPH 749
- 9.2 Systems of Equations in Three Variables** 754
Solving Systems of Equations in Three Variables / Applications / Mathematical Models and Applications
- 9.3 Matrices and Systems of Equations** 764
Matrices and Row-Equivalent Operations / Gaussian Elimination with Matrices / Gauss–Jordan Elimination

- 9.4 Matrix Operations 772**
Matrix Addition and Subtraction / Scalar Multiplication /
Products of Matrices / Matrix Equations
MID-CHAPTER MIXED REVIEW 783
- 9.5 Inverses of Matrices 785**
The Identity Matrix / The Inverse of a Matrix / Solving Systems of Equations
- 9.6 Determinants and Cramer's Rule 792**
Determinants of Square Matrices / Evaluating Determinants Using Cofactors /
Cramer's Rule
- 9.7 Systems of Inequalities and Linear Programming 800**
Graphs of Linear Inequalities / Systems of Linear Inequalities /
Applications: Linear Programming
- 9.8 Partial Fractions 813**
Partial Fraction Decompositions
Study Guide 819
Review Exercises 825
Chapter Test 829

10**Analytic Geometry Topics****831**

- 10.1 The Parabola 832**
Parabolas / Finding Standard Form by Completing the Square / Applications
- 10.2 The Circle and the Ellipse 840**
Circles / Ellipses / Applications
- 10.3 The Hyperbola 851**
Standard Equations of Hyperbolas / Applications
- 10.4 Nonlinear Systems of Equations and Inequalities 861**
Nonlinear Systems of Equations / Modeling and Problem Solving /
Nonlinear Systems of Inequalities
VISUALIZING THE GRAPH 869
MID-CHAPTER MIXED REVIEW 874
- 10.5 Rotation of Axes 875**
Rotation of Axes / The Discriminant
- 10.6 Polar Equations of Conics 885**
Polar Equations of Conics / Converting from Polar Equations to Rectangular
Equations / Finding Polar Equations of Conics
- 10.7 Parametric Equations 891**
Graphing Parametric Equations / Determining a Rectangular Equation
for Given Parametric Equations / Determining Parametric Equations
for a Given Rectangular Equation / Applications
Study Guide 898
Review Exercises 905
Chapter Test 908

11

Sequences, Series, and Combinatorics

911

- 11.1 Sequences and Series** 912
Sequences / Finding the General Term / Sums and Series /
Sigma Notation / Recursive Definitions
- 11.2 Arithmetic Sequences and Series** 920
Arithmetic Sequences / Sum of the First n Terms of an Arithmetic
Sequence / Applications
- 11.3 Geometric Sequences and Series** 929
Geometric Sequences / Sum of the First n Terms of a Geometric Sequence /
Infinite Geometric Series / Applications
VISUALIZING THE GRAPH 936
- 11.4 Mathematical Induction** 940
Proving Infinite Sequences of Statements
MID-CHAPTER MIXED REVIEW 945
- 11.5 Combinatorics: Permutations** 947
Permutations / Factorial Notation / Permutations of n Objects Taken
 k at a Time / Permutations of Sets with Nondistinguishable Objects
- 11.6 Combinatorics: Combinations** 956
Combinations
- 11.7 The Binomial Theorem** 964
Binomial Expansions Using Pascal's Triangle / Binomial Expansion Using
Factorial Notation / Finding a Specific Term / Total Number of Subsets
- 11.8 Probability** 971
Experimental and Theoretical Probability / Computing Experimental Probabilities /
Theoretical Probability
Study Guide 981
Review Exercises 985
Chapter Test 987

Photo Credits 989

Answers A-1

Index of Applications I-1

Index I-5

Preface

Note to Students In writing this textbook we challenged ourselves to do everything possible to help you learn the concepts and skills contained between its covers so that you will be successful in this course and in the mathematics courses you take in the future. Every feature we have included was done with this in mind. We realize that your time is both valuable and limited, so we communicate in a highly visual way that allows you to focus easily and learn quickly and efficiently. We feel confident that, if you are willing to invest an adequate amount of your time in the learning process, this text will be of great value to you.

Best wishes for a positive learning experience,
Judy Beecher
Judy Penna
Marv Bittinger

Precalculus, Fourth Edition, covers college-level precalculus and is appropriate for a one- or two-term course in precalculus mathematics. This textbook is known for enabling students to “see the math” through its focus on visualization, early introduction to functions, and making connections between math concepts and the real world. Additional information is presented on these themes in the pages that follow.

With the new edition, we continue to innovate by incorporating more ongoing review to help students develop understanding and study effectively. We have new Mid-Chapter Mixed Review exercise sets to give students an extra opportunity to master concepts and new Study Guides which provide built-in tools to help prepare for tests. Specific content changes to the Fourth Edition are outlined below.

MyMathLab[®] has been expanded so that the online content is even more integrated with the text’s approach, with the addition of Vocabulary, Synthesis, and Mid-Chapter Mixed Review exercises from the text as well as example-based videos that we created.

Our overarching goal is to provide students with a learning experience that will not only lead to success in this course but also prepare them to be successful in the mathematics courses they take in the future.

► Content Changes to the Fourth Edition

In this Fourth Edition, we have changed the table of contents to make the material at the beginning of the text more easily taught and learned. We have balanced and evened out the lengths of Chapters 1–3 in the Third Edition by presenting the material in four chapters in the Fourth Edition.

By spreading this material out over four chapters and presenting it in a different order, we provide the student with a more even-handed and consistent introduction to Precalculus. The new arrangement is well suited to a one-section-per-lecture class format. We think students and instructors alike will be pleased with the changes that have been made.

- The material on increasing, decreasing, and piecewise functions, along with the discussion of the algebra of functions, composition of functions, and symmetry and transformations that was in Chapter 1 in the Third Edition, has been moved to a separate chapter (Chapter 2) in the Fourth Edition.
- The algebra of functions and composition of functions are now presented in two sections rather than one.
- The material on linear equations, linear functions, and linear inequalities has been moved from Chapter 2 in the Third Edition, to Chapter 1 in the Fourth Edition, where functions are introduced.
- The chapter on polynomial functions and rational functions has been shortened by moving the section on variation to Chapter 2 in the Fourth Edition.
- The discussion of equations and inequalities with absolute value that was presented in different sections in the Third Edition is now combined in a single section in the Fourth Edition.
- In Chapter R, the review chapter, the section that reviews equation solving has been moved to appear now before the sections on rational expressions, radical notation, and rational exponents.
- The material on solving formulas for a specified letter has been moved from Chapter 2 in the Third Edition to Chapter R in the Fourth Edition so that it can be reviewed before it is used to solve a linear equation for one of the variables in Chapter 1.

► Emphasis on Functions

Functions are the core of this course and should be presented as a thread that runs throughout the course rather than as an isolated topic. We introduce functions in Chapter 1, whereas many traditional precalculus textbooks cover equation-solving in Chapter 1. Our approach of introducing students to a relatively new concept at the beginning of the course, rather than requiring them to begin with a review of material that was previously covered in intermediate algebra, immediately engages them and serves to help them avoid the temptation not to study early in the course because “I already know this.”

The concept of a function can be challenging for students. By repeatedly exposing them to the language, notation, and use of functions, demonstrating visually how functions relate to equations and graphs, and also showing how functions can be used to model real data, we hope to ensure that students not only become comfortable with functions but also come to understand and appreciate them. You will see this emphasis on functions woven throughout the other themes that follow.

■ **Classify the Function Exercises** With a focus on conceptual understanding, students are asked periodically to identify a number of functions by their type (linear, quadratic, rational, and so on). As students progress through the text, the variety of functions with which they are familiar increases and these exercises become more challenging. The “classifying the function” exercises appear with the review exercises in the Skill Maintenance portion of an exercise set. (See pp. 339, 438, and 567.)

► Visual Emphasis

Our early introduction of functions allows graphs to be used to provide a visual aspect to solving equations and inequalities. For example, we are able to show students both algebraically and visually that the solutions of a quadratic equation $ax^2 + bx + c = 0$ are the zeros of the quadratic function $f(x) = ax^2 + bx + c$ as well as the first coordinates of the x -intercepts of

the graph of that function. This makes it possible for students, particularly visual learners, to gain a quick understanding of these concepts. (See pp. 249, 252, 297, 360, 425, and 631.)

■ **Visualizing the Graph** Appearing at least once in every chapter, this feature provides students with an opportunity to match an equation with its graph by focusing on the characteristics of the equation and the corresponding attributes of the graph. (See pp. 205, 266, 356, and 565.) In addition to this full-page feature, many of the exercise sets include exercises in which the student is asked to match an equation with its graph or to find an equation of a function from its graph. (See pp. 208, 209, 306, and 408–409.) In MyMathLab, animated Visualizing the Graph features for each chapter allow students to interact with graphs on a whole new level.

■ **Side-by-Side Examples** Many examples are presented in a side-by-side, two-column format in which the algebraic solution of an equation appears in the left column and a graphical interpretation of the solution appears in the right column. (See pp. 242, 363–364, 443–444, and 627.) This enables students to visualize and comprehend the connections among the solutions of an equation, the zeros of a function, and the x -intercepts of the graph of a function.

■ **Technology Connections** This feature appears throughout the text to demonstrate how a graphing calculator can be used to solve problems. The technology is set apart from the traditional exposition so that it does not intrude if no technology is desired. Although students might not be using graphing calculators, the graphing calculator windows that appear in the Technology Connection features enhance the visual element of the text, providing graphical interpretations of solutions of equations, zeros of functions, and x -intercepts of graphs of functions. (See pp. 80, 250, 442, 526, and 633.) A graphing calculator manual providing keystroke-level instruction, written by author Judy Penna, is available online. (See Student Supplements.)

► Making Connections

■ **Zeros, Solutions, and x -Intercepts** We find that when students understand the connections among the real zeros of a function, the solutions of its associated equation, and the first coordinates of the x -intercepts of its graph, a door opens to a new level of mathematical comprehension that increases the probability of success in this course. We emphasize zeros, solutions, and x -intercepts throughout the text by using consistent, precise terminology and including exceptional graphics. Seeing this theme repeated in different contexts leads to a better understanding and retention of these concepts. (See pp. 243, 252, and 631.)

■ **Connecting the Concepts** This feature highlights the importance of connecting concepts. When students are presented with concepts in visual form—using graphs, an outline, or a chart—rather than merely in paragraphs of text, comprehension is streamlined and retention is enhanced. The visual aspect of this feature invites students to stop and check their understanding of how concepts work together in one section or in several sections. This check in turn enhances student performance on homework assignments and exams. (See pp. 132, 252, 328, and 545.)

■ **Annotated Examples** We have included over 1070 Annotated Examples designed to fully prepare the student to work the exercises. Learning is carefully guided with the use of numerous color-coded art pieces and step-by-step annotations. Substitutions and annotations are highlighted in red for emphasis. (See pp. 245, 433, and 586.)

■ **Now Try Exercises** Now Try Exercises are found after nearly every example. This feature encourages active learning by asking students to do an exercise in the exercise set that is similar to the example the student has just read. (See pp. 243, 347, 402, and 510.)

■ **Synthesis Exercises** These exercises appear at the end of each exercise set and encourage critical thinking by requiring students to synthesize concepts from several sections or to take a concept a step further than in the general exercises. For the Fourth Edition, these exercises are assignable in MyMathLab. (See pp. 327–328, 412, 464, and 535.)

■ **Real-Data Applications** We encourage students to see and interpret the mathematics that appears every day in the world around them. Throughout the writing process, we conducted an energetic search for real-data applications, and the result is a variety of examples and exercises that connect the mathematical content with everyday life. Most of these applications feature source lines and many include charts and graphs. Many are drawn from the fields of health, business and economics, life and physical sciences, social science, and areas of general interest such as sports and travel. (See pp. 98, 255, 410, 461, and 654.)

► Ongoing Review

The most significant addition to the Fourth Edition is the new ongoing review features that have been integrated throughout to help students reinforce their understanding and improve their success in the course.

New! ■ **Mid-Chapter Mixed Review** This new review reinforces understanding of the mathematical concepts and skills covered in the first half of the chapter before students move on to new material in the second half of the chapter. Each review begins with at least three True/False exercises that require students to consider the concepts they have studied and also contains exercises that drill the skills from all prior sections of the chapter. These exercises are assignable in MyMathLab. (See pp. 187–188, 429–430, and 519–520.)

Collaborative Discussion and Writing Exercises appear in the Mid-Chapter Mixed Review as well. These exercises can be discussed in small groups or by the class as a whole to encourage students to talk about the key mathematical concepts in the chapter. They can also be assigned to individual students to give them an opportunity to write about mathematics. (See pp. 271, 329, and 520.)

A section reference is provided for each exercise in the Mid-Chapter Mixed Review. This tells the student which section to refer to if help is needed to work the exercise. Answers to all exercises in the Mid-Chapter Mixed Review are given at the back of the book.

New! ■ **Study Guide** This new feature is found at the beginning of the **Summary and Review** near the end of each chapter. Presented in a two-column format organized by section, this feature gives key concepts and terms in the left column and a worked-out example in the right column. It provides students with a concise and effective review of the chapter that is a solid basis for studying for a test. In MyMathLab, these narrated Study Guides reinforce the key concepts and ideas. (See pp. 285–289, 465–471, and 569–578.)

■ **Exercise Sets** There are over 7700 exercises in this text. The exercise sets are enhanced with real-data applications and source lines, detailed art pieces, tables, graphs, and photographs. In addition to the exercises that provide students with concepts presented in the section, the exercise sets feature the following elements to provide ongoing review of topics presented earlier:

- **Skill Maintenance Exercises.** These exercises provide an ongoing review of concepts previously presented in the course, enhancing students' retention of these concepts. These exercises include **Vocabulary Review**, described below, and **Classifying the Function** exercises, described earlier in the section "Emphasis on Functions." Answers to all Skill Maintenance exercises appear in the answer section at the back of the book, along with a section reference that directs students quickly and efficiently to the appropriate section of the text if they need help with an exercise. (See pp. 209, 280, 359, 428, and 550.)
- **Enhanced Vocabulary Review Exercises.** This feature checks and reviews students' understanding of the vocabulary introduced throughout the text. It appears once in every chapter, in the Skill Maintenance portion of an exercise set, and is intended to provide a continuing review of the terms that students must know in order to be able to communicate effectively in the language of mathematics. (See pp. 219, 284, 359, and 535.) These are now assignable in MyMathLab and can serve as reading quizzes.
- **Enhanced Synthesis Exercises.** These exercises are described under the Making Connections heading and are also assignable in MyMathLab.

■ **Review Exercises** These exercises in the **Summary and Review** supplement the Study Guide by providing a thorough and comprehensive review of the skills taught in the chapter. A group of true/false exercises appears first, followed by a large number of exercises that drill the skills and concepts taught in the chapter. In addition, three multiple-choice exercises, one of which involves identifying the graph of a function, are included in the Review Exercises for every chapter with the exception of Chapter R, the review chapter. Each Review Exercise is accompanied by a section reference that, as in the Mid-Chapter Mixed Review, directs students to the section in which the material being reviewed can be found. Collaborative Discussion and Writing exercises are also included. These exercises are described under the Mid-Chapter Mixed Review heading on p. xiv. (See pp. 289–292, 471–474, and 578–581.)

■ **Chapter Test** The test at the end of each chapter allows students to test themselves and target areas that need further study before taking the in-class test. Each Chapter Test includes a multiple-choice exercise involving identifying the graph of a function (except in Chapter R, in which graphing has not yet been introduced). Answers to all questions in the Chapter Tests appear in the answer section at the back of the book, along with corresponding section references. (See pp. 292–293, 475–476, and 581–582.)

■ **Review Icons** Placed next to the concept that a student is currently studying, a review icon references a section of the text in which the student can find and review topics on which the current concept is built. (See pp. 341, 388, and 588.)

■ **Study Tips** The Study Tips that appear in the text margin provide helpful study hints and promote effective study habits such as good note taking and exam preparation. These tips help students make the connection between study skills and the material being studied. (See pp. 160, 190, 315, and 480.)

► Supplements

Student Supplements

Student's Solutions Manual

ISBN: 0-321-72564-6; 978-0-321-72564-6

- By Judith A. Penna
- Contains completely worked-out solutions with step-by-step annotations for all the odd-numbered exercises in the exercise sets, the Mid-Chapter Mixed Review exercises, and Chapter Review exercises, as well as solutions for all the Chapter Test exercises

Video Resources on DVD-ROM with Optional Subtitles

ISBN: 0-321-72565-4; 978-0-321-72565-3

- Complete set of digitized videos on DVD-ROM for student use at home or on campus
- Ideal for distance learning or supplemental instruction
- Features authors Judy Beecher and Judy Penna working through and explaining examples in the text

Graphing Calculator Manual

- By Judith A. Penna
- Contains keystroke-level instruction for the Texas Instruments TI-83 Plus, TI-84 Plus, and TI-89
- Teaches students how to use a graphing calculator using actual examples and exercises from the main text
- Mirrors the topic order in the main text to provide a just-in-time mode of instruction
- Available for download through www.pearsonhighered.com/irc or inside your MyMathLab course

Instructor Supplements

Annotated Instructor's Edition

ISBN: 0-321-69411-2; 978-0-321-69411-9

- Includes all the answers to the exercise sets, usually right on the page where the exercises appear
- Readily accessible answers help both new and experienced instructors prepare for class efficiently
- Sample homework assignments are now indicated by a blue underline within each end-of-section exercise set and may be assigned in MyMathLab

Instructor's Solutions Manual

ISBN: 0-321-72562-X; 978-0-321-72562-2

- By Judith A. Penna
- Contains worked-out solutions to all exercises in the exercise sets and solutions for all Mid-Chapter Mixed Review exercises, Chapter Review exercises, and Chapter Test exercises

Online Test Bank

- By Laurie Hurley
- Contains four free-response test forms for each chapter following the same format and having the same level of difficulty as the tests in the main text, plus two multiple-choice test forms for each chapter
- Provides six forms of the final examination, four with free-response questions and two with multiple-choice questions
- Available for download through www.pearsonhighered.com/irc or inside your MyMathLab course

TestGen®

- Enables instructors to build, edit, print, and administer tests
- Features a computerized bank of questions developed to cover all text objectives
- Available for download through www.pearsonhighered.com/irc or inside your MyMathLab course

Pearson Adjunct Support Center

- Offers consultation on suggested syllabi, helpful tips for using the textbook support package, assistance with content, and advice on classroom strategies
- Available Sunday through Thursday evenings from 5 P.M. to midnight EST
- e-mail: AdjunctSupport@aw.com; Telephone: 1-800-435-4084; fax: 1-877-262-9774

► Media Supplements

MyMathLab® Online Course (Access code required.)

MyMathLab® is a series of text-specific, easily customizable online courses for Pearson Education's textbooks in mathematics and statistics. MyMathLab gives you the tools you need to deliver all or a portion of your course online, whether your students are in a lab or working from home. MyMathLab provides a rich and flexible set of course materials, featuring free-response exercises that are algorithmically generated for unlimited practice and mastery. Students can also use online tools, such as video lectures, animations, and a multimedia textbook, to independently improve their understanding and performance. Instructors can use MyMathLab's homework and test managers to select and assign online exercises correlated directly to the textbook, as well as media related to that textbook, and they can also create and assign their own online exercises and import TestGen® tests for added flexibility. MyMathLab's online gradebook—designed specifically for mathematics and statistics—automatically tracks students' homework and test results and gives you control over how to calculate final grades. You can also add offline (paper-and-pencil) grades to the gradebook.

MyMathLab is now more closely integrated with the text and now offers new question types, for a more robust online experience that mirrors the authors' approach.

- **Example-based videos**, created by the authors themselves, walk students through the detailed solution process for key examples in the textbook. Videos have optional subtitles.
- **Vocabulary exercises** which can serve as reading quizzes have been added.
- **Mid-Chapter Mixed Reviews** are new to the text and are assignable online, helping students to reinforce their understanding of the concepts.
- **Synthesis exercises** are now assignable online, testing students' ability to answer questions that cover multiple concepts.
- **Sample homework assignments** are now indicated by a blue underline within each end-of-section exercise set and may be assigned in MyMathLab.
- **Study Guides** are new to the text. In MyMathLab, these narrated Study Guides reinforce the key concepts and ideas.

MyMathLab also includes access to the **Pearson Tutor Center** (www.pearson tutorservices.com). The Tutor Center is staffed by qualified mathematics instructors who provide textbook-specific tutoring for students via toll-free phone, fax, e-mail, and interactive Web sessions. MyMathLab is available to qualified adopters. For more information, visit our website at www.mymathlab.com or contact your Pearson representative.

MathXL® Online Course (Access code required.)

MathXL® is a powerful online homework, tutorial, and assessment system that accompanies Pearson Education's textbooks in mathematics and statistics. With MathXL, instructors can

- Create, edit, and assign online homework and tests using algorithmically generated exercises correlated at the objective level to the textbook.
- Create and assign their own online exercises and import TestGen tests for added flexibility.
- Maintain records of all student work tracked in MathXL's online gradebook.

With MathXL, students can

- Take chapter tests in MathXL and receive personalized study plans and/or personalized homework assignments based on their test results.
- Use the study plan and/or the homework to link directly to tutorial exercises for the objectives they need to study.
- Access supplemental animations and video clips directly from selected exercises.

MathXL is available to qualified adopters. For more information, visit our website at www.mathxl.com, or contact your Pearson representative.

Videos

The video lectures for this text are available on DVD-ROM, making it easy and convenient for students to watch the videos from a computer either at home or on campus. The videos feature authors Judy Beecher and Judy Penna, who present Example Solutions. Example Solutions walk students through the detailed solution process for the examples in the textbook. The format provides distance-learning students with comprehensive video instruction, but also allows students needing less review to watch instruction on a specific skill or procedure. The videos have optional text subtitles, which can be easily turned on or off for individual student needs. Subtitles are available in English and Spanish.

PowerPoints

PowerPoint Lecture Slides feature presentations written and designed specifically for this text. These lecture slides provide an outline to use in a lecture setting, presenting definitions, figures, and key examples from the text. They are available online within MML or from the Instructor Resource Center at www.pearsonhighered.com/irc.

► Acknowledgments

We wish to express our heartfelt thanks to a number of people who have contributed in special ways to the development of this textbook. Our editor, Anne Kelly, encouraged and supported our vision. We are very appreciative of the marketing insight provided by Roxanne McCarley, our marketing manager, and of the support that we received from the entire Addison-Wesley Higher Education Group, including Kathy Manley, senior production project manager, Joanne Dill, senior content editor, Brendan Berger, editorial assistant, and Katherine Minton, marketing assistant. We also thank Shana Siegmund, media producer, for her creative work on the media products that accompany this text. And we are immensely grateful to Martha Morong for her copyediting, to Sally Lifland for her production services, and to Geri Davis for her text design and art editing, and for the endless hours of hard work they have done to make this a book of which we are proud. We also thank Laurie Hurley, Joanne Koratich, Patty LaGree, Holly Martinez, and Jennifer Rosenberg for their meticulous accuracy checking and proofreading of the text.

The following reviewers made invaluable contributions to the development of the Fourth Edition and we thank them for that:

Michelle Askew, *Lamar State College—Port Arthur*
 Stacie Badran, *Embry-Riddle Aeronautical University*
 Sherry S. Biggers, *Clemson University Department of Mathematical Sciences*
 Gary Brice, *Lamar University*
 Christine Bush, *Palm Beach Community College, Lake Worth*
 Walter Czarneck, *Framingham State College*
 Randy Ellen Davidson, *Clemson University*
 Joseph De Guzman, *Riverside College, Norco Campus*
 Douglas Dunbar, *Okaloosa-Walton Community College*
 Sam Evers, *University of Alabama—Tuscaloosa*
 Wayne Ferguson, *Northwest Mississippi Community College*
 Joseph Gaskin, *State University of New York, Oswego*

Sunshine Gibbons, *Southeast Missouri State University*
Dauhrice K. Gibson (retired), *Gulf Coast Community College*
Jim Graziose, *Palm Beach Community College*
Joseph Lloyd Harris, *Gulf Coast Community College*
Susan K. Hitchcock, *Palm Beach Community College*
Sharon S. Hudson, *Gulf Coast Community College*
Jennifer Jameson, *Coconino Community College, Flagstaff*
Cheryl Kane, *University of Nebraska*
Marjorie S. LaSalle, *DeKalb College*
Susan Leland, *Montana Tech of the University of Montana*
Bernard F. Mathon, *Miami-Dade College*
Debra McCandrew, *Florence-Darlington Technical College*
Barry J. Monk, *Macon State College*
Darla Ottman, *Elizabethtown Community College*
Vicki Partin, *Lexington Community College*
Martha Pate, *Lamar State College—Port Arthur*
Leslie Richardson, *College of the Mainland*
Kathy V. Rodgers, *University of Southern Indiana*
Lucille Roth, *Tech of the Low Country*
Abdelrida Saleh, *Miami-Dade College*
Russell Simmons, *Brookhaven College*
Rajalakshmi Sriram, *Okaloosa-Walton Community College*

J. A. B.
J. A. P.
M. L. B.

This page intentionally left blank

Precalculus

This page intentionally left blank

Basic Concepts of Algebra

CHAPTER

R



Application

It is estimated that there were 51.2 billion pieces of trash on 76 million mi of U.S. roadways in a recent year (*Source: Keep America Beautiful*). On average, how many pieces of trash were on each mile of roadway?



This problem appears as Exercise 79 in Section R.2.

- R.1** The Real-Number System
- R.2** Integer Exponents, Scientific Notation, and Order of Operations
- R.3** Addition, Subtraction, and Multiplication of Polynomials
- R.4** Factoring
- R.5** The Basics of Equation Solving
- R.6** Rational Expressions
- R.7** Radical Notation and Rational Exponents

Study Guide

Review Exercises

Chapter Test

The Real-Number System

R.1

- ▶ Identify various kinds of real numbers.
- ▶ Use interval notation to write a set of numbers.
- ▶ Identify the properties of real numbers.
- ▶ Find the absolute value of a real number.

▶ Real Numbers

In applications of algebraic concepts, we use real numbers to represent quantities such as distance, time, speed, area, profit, loss, and temperature. Some frequently used sets of real numbers and the relationships among them are shown below.

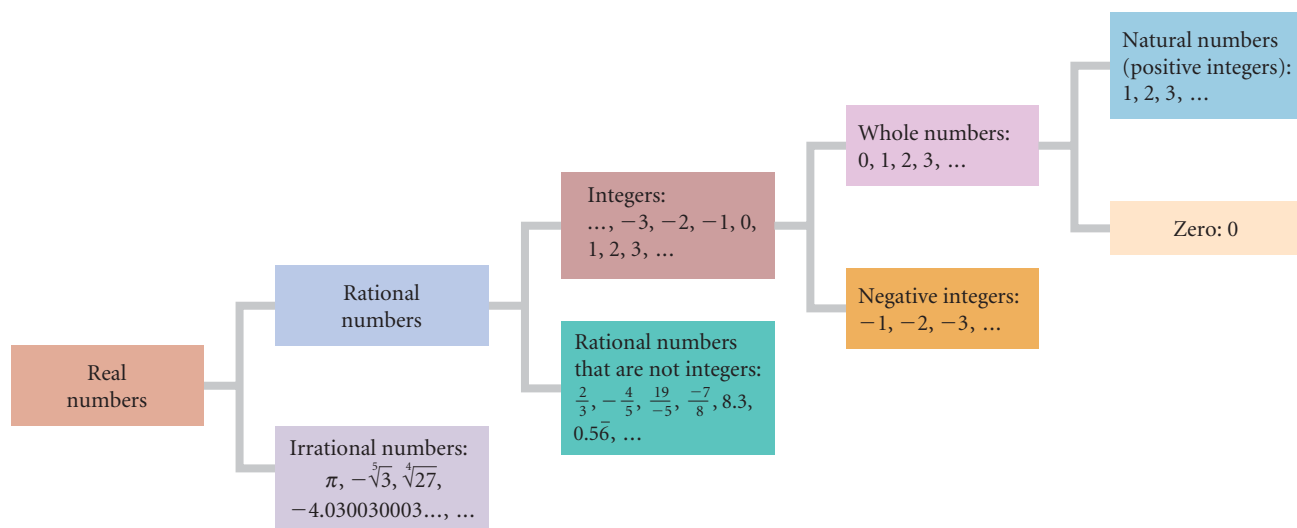

Numbers that can be expressed in the form p/q , where p and q are integers and $q \neq 0$, are **rational numbers**. Decimal notation for rational numbers either *terminates* (ends) or *repeats*. Each of the following is a rational number.

- a) 0 $0 = \frac{0}{a}$ for any nonzero integer a
- b) -7 $-7 = \frac{-7}{1}$, or $\frac{7}{-1}$
- c) $\frac{1}{4} = 0.25$ Terminating decimal
- d) $-\frac{5}{11} = -0.454545 \dots = -0.\overline{45}$ Repeating decimal
- e) $\frac{5}{6} = 0.8333 \dots = 0.8\overline{3}$ Repeating decimal

The real numbers that are not rational are **irrational numbers**. Decimal notation for irrational numbers neither terminates nor repeats. Each of the following is an irrational number.

- a) $\pi = 3.1415926535 \dots$ **There is no repeating block of digits.**
 ($\frac{22}{7}$ and 3.14 are rational *approximations* of the irrational number π .)
- b) $\sqrt{2} = 1.414213562 \dots$ **There is no repeating block of digits.**
- c) $-6.12122122212222 \dots$ **Although there is a pattern, there is no repeating block of digits.**

The set of all rational numbers combined with the set of all irrational numbers gives us the set of **real numbers**. The real numbers are modeled using a **number line**, as shown below.

Each point on the line represents a real number, and every real number is represented by a point on the line.



The order of the real numbers can be determined from the number line. If a number a is to the left of a number b , then a is **less than** b ($a < b$). Similarly, a is **greater than** b ($a > b$) if a is to the right of b on the number line. For example, we see from the number line above that $-2.9 < -\frac{3}{5}$, because -2.9 is to the left of $-\frac{3}{5}$. Also, $\frac{17}{4} > \sqrt{3}$, because $\frac{17}{4}$ is to the right of $\sqrt{3}$.

The statement $a \leq b$, read “ a is less than or equal to b ,” is true if either $a < b$ is true or $a = b$ is true.

The symbol \in is used to indicate that a member, or **element**, belongs to a set. Thus if we let \mathbb{Q} represent the set of rational numbers, we can see from the diagram on p. 2 that $0.5\bar{6} \in \mathbb{Q}$. We can also write $\sqrt{2} \notin \mathbb{Q}$ to indicate that $\sqrt{2}$ is *not* an element of the set of rational numbers.

When *all* the elements of one set are elements of a second set, we say that the first set is a **subset** of the second set. The symbol \subseteq is used to denote this. For instance, if we let \mathbb{R} represent the set of real numbers, we can see from the diagram that $\mathbb{Q} \subseteq \mathbb{R}$ (read “ \mathbb{Q} is a subset of \mathbb{R} ”).

► Interval Notation

Sets of real numbers can be expressed using **interval notation**. For example, for real numbers a and b such that $a < b$, the **open interval** (a, b) is the set of real numbers between, but not including, a and b . That is,

$$(a, b) = \{x \mid a < x < b\}.$$

The points a and b are **endpoints** of the interval. The parentheses indicate that the endpoints are not included in the interval.







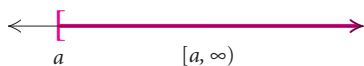
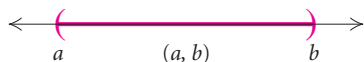

Some intervals extend without bound in one or both directions. The interval $[a, \infty)$, for example, begins at a and extends to the right without bound, that is,

$$[a, \infty) = \{x \mid x \geq a\}.$$

The bracket indicates that a is included in the interval.



The various types of intervals are listed below.

Intervals: Types, Notation, and Graphs			
TYPE	INTERVAL NOTATION	SET NOTATION	GRAPH
Open	(a, b)	$\{x \mid a < x < b\}$	
Closed	$[a, b]$	$\{x \mid a \leq x \leq b\}$	
Half-open	$[a, b)$	$\{x \mid a \leq x < b\}$	
Half-open	$(a, b]$	$\{x \mid a < x \leq b\}$	
Open	(a, ∞)	$\{x \mid x > a\}$	
Half-open	$[a, \infty)$	$\{x \mid x \geq a\}$	
Open	$(-\infty, b)$	$\{x \mid x < b\}$	
Half-open	$(-\infty, b]$	$\{x \mid x \leq b\}$	

The interval $(-\infty, \infty)$, graphed below, names the set of all real numbers, \mathbb{R} .



EXAMPLE 1 Write interval notation for each set and graph the set.

- a) $\{x \mid -4 < x < 5\}$ b) $\{x \mid x \geq 1.7\}$
 c) $\{x \mid -5 < x \leq -2\}$ d) $\{x \mid x < \sqrt{5}\}$

Solution

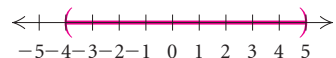
a) $\{x \mid -4 < x < 5\} = (-4, 5)$; 

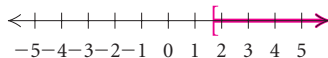
b) $\{x \mid x \geq 1.7\} = [1.7, \infty)$; 

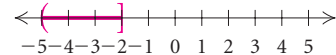
c) $\{x \mid -5 < x \leq -2\} = (-5, -2]$; 

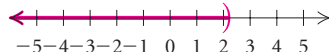
d) $\{x \mid x < \sqrt{5}\} = (-\infty, \sqrt{5})$; 

 **Now Try Exercises 13 and 15.**

► Properties of the Real Numbers

The following properties can be used to manipulate algebraic expressions as well as real numbers.

Properties of the Real Numbers

For any real numbers a , b , and c :

$$a + b = b + a \text{ and}$$

$$ab = ba$$

Commutative properties of addition and multiplication

$$a + (b + c) = (a + b) + c \text{ and}$$

$$a(bc) = (ab)c$$

Associative properties of addition and multiplication

$$a + 0 = 0 + a = a$$

Additive identity property

$$-a + a = a + (-a) = 0$$

Additive inverse property

$$a \cdot 1 = 1 \cdot a = a$$

Multiplicative identity property

$$a \cdot \frac{1}{a} = \frac{1}{a} \cdot a = 1 \quad (a \neq 0)$$

Multiplicative inverse property

$$a(b + c) = ab + ac$$

Distributive property

Note that the distributive property is also true for subtraction since $a(b - c) = a[b + (-c)] = ab + a(-c) = ab - ac$.

EXAMPLE 2 State the property being illustrated in each sentence.

a) $8 \cdot 5 = 5 \cdot 8$

b) $5 + (m + n) = (5 + m) + n$

c) $14 + (-14) = 0$

d) $6 \cdot 1 = 1 \cdot 6 = 6$

e) $2(a - b) = 2a - 2b$

Solution

SENTENCE	PROPERTY
a) $8 \cdot 5 = 5 \cdot 8$	Commutative property of multiplication: $ab = ba$
b) $5 + (m + n) = (5 + m) + n$	Associative property of addition: $a + (b + c) = (a + b) + c$
c) $14 + (-14) = 0$	Additive inverse property: $a + (-a) = 0$
d) $6 \cdot 1 = 1 \cdot 6 = 6$	Multiplicative identity property: $a \cdot 1 = 1 \cdot a = a$
e) $2(a - b) = 2a - 2b$	Distributive property: $a(b + c) = ab + ac$

 **Now Try Exercises 49 and 55.**

► Absolute Value

The number line can be used to provide a geometric interpretation of *absolute value*. The **absolute value** of a number a , denoted $|a|$, is its distance from 0 on the number line. For example, $|-5| = 5$, because the distance of -5 from 0 is 5. Similarly, $|\frac{3}{4}| = \frac{3}{4}$, because the distance of $\frac{3}{4}$ from 0 is $\frac{3}{4}$.

Absolute Value

For any real number a ,

$$|a| = \begin{cases} a, & \text{if } a \geq 0, \\ -a, & \text{if } a < 0. \end{cases}$$

When a is nonnegative, the absolute value of a is a . When a is negative, the absolute value of a is the opposite, or additive inverse, of a . Thus, $|a|$ is never negative; that is, for any real number a , $|a| \geq 0$.

Absolute value can be used to find the distance between two points on the number line.

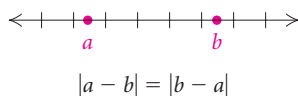

Distance Between Two Points on the Number Line

For any real numbers a and b , the **distance between a and b** is $|a - b|$, or equivalently, $|b - a|$.

TECHNOLOGY CONNECTION

We can use the absolute-value operation on a graphing calculator to find the distance between two points. On many graphing calculators, absolute value is denoted “abs” and is found in the MATH NUM menu and also in the CATALOG.

abs (-2-3)	5
abs (3-(-2))	5

EXAMPLE 3 Find the distance between -2 and 3 .

Solution The distance is

$$\begin{aligned} |-2 - 3| &= |-5| = 5, & \text{or equivalently,} \\ |3 - (-2)| &= |3 + 2| = |5| = 5. \end{aligned}$$

➔ Now Try Exercise 69.

R.1

Exercise Set

In Exercises 1–10, consider the numbers

$$\frac{2}{3}, 6, \sqrt{3}, -2.45, \sqrt[6]{26}, 18.\bar{4}, -11, \sqrt[3]{27}, 5\frac{1}{6}, 7.151551555\dots, -\sqrt{35}, \sqrt[5]{3}, -\frac{8}{7}, 0, \sqrt{16}.$$

- Which are rational numbers?
- Which are natural numbers?
- Which are irrational numbers?
- Which are integers?
- Which are whole numbers?
- Which are real numbers?
- Which are integers but not natural numbers?
- Which are integers but not whole numbers?
- Which are rational numbers but not integers?
- Which are real numbers but not integers?

Write interval notation. Then graph the interval.

- $\{x \mid -5 \leq x \leq 5\}$
- $\{x \mid -2 < x < 2\}$
- $\{x \mid -3 < x \leq -1\}$
- $\{x \mid 4 \leq x < 6\}$
- $\{x \mid x \leq -2\}$
- $\{x \mid x > -5\}$
- $\{x \mid x > 3.8\}$
- $\{x \mid x \geq \sqrt{3}\}$
- $\{x \mid 7 < x\}$
- $\{x \mid -3 > x\}$

Write interval notation for the graph.

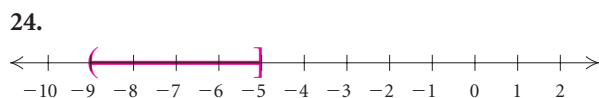
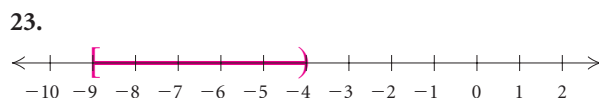
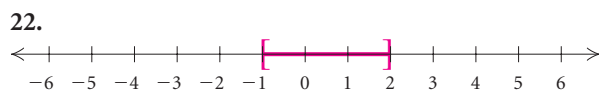
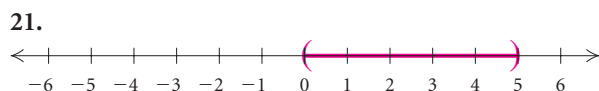

In Exercises 29–46, the following notation is used: \mathbb{N} = the set of natural numbers, \mathbb{W} = the set of whole numbers, \mathbb{Z} = the set of integers, \mathbb{Q} = the set of rational numbers, \mathbb{I} = the set of irrational numbers, and \mathbb{R} = the set of real numbers. Classify the statement as true or false.

- $6 \in \mathbb{N}$
- $0 \notin \mathbb{N}$
- $3.2 \in \mathbb{Z}$
- $-10.\bar{1} \in \mathbb{R}$
- $-\frac{11}{5} \in \mathbb{Q}$
- $-\sqrt{6} \in \mathbb{Q}$
- $\sqrt{11} \notin \mathbb{R}$
- $-1 \in \mathbb{W}$
- $24 \notin \mathbb{W}$
- $1 \in \mathbb{Z}$
- $1.089 \notin \mathbb{I}$
- $\mathbb{N} \subseteq \mathbb{W}$
- $\mathbb{W} \subseteq \mathbb{Z}$
- $\mathbb{Z} \subseteq \mathbb{N}$
- $\mathbb{Q} \subseteq \mathbb{R}$
- $\mathbb{Z} \subseteq \mathbb{Q}$
- $\mathbb{R} \subseteq \mathbb{Z}$
- $\mathbb{Q} \subseteq \mathbb{I}$

Name the property illustrated by the sentence.

- $3 + y = y + 3$
- $6(xz) = (6x)z$
- $-3 \cdot 1 = -3$
- $4(y - z) = 4y - 4z$
- $5 \cdot x = x \cdot 5$
- $7 + (x + y) = (7 + x) + y$
- $2(a + b) = (a + b)2$

54. $-11 + 11 = 0$
 55. $-6(m + n) = -6(n + m)$
 56. $t + 0 = t$
 57. $8 \cdot \frac{1}{8} = 1$
 58. $9x + 9y = 9(x + y)$

Simplify.

59. $|-8.15|$ 60. $|-14.7|$
 61. $|295|$ 62. $|-93|$
 63. $|-\sqrt{97}|$ 64. $\left|\frac{12}{19}\right|$
 65. $|0|$ 66. $|15|$
 67. $\left|\frac{5}{4}\right|$ 68. $|-\sqrt{3}|$

Find the distance between the given pair of points on the number line.

69. $-8, 14$ 70. $-5.2, 0$
 71. $-9, -3$ 72. $\frac{15}{8}, \frac{23}{12}$
 73. $6.7, 12.1$ 74. $-15, -6$
 75. $-\frac{3}{4}, \frac{15}{8}$ 76. $-3.4, 10.2$
 77. $-7, 0$ 78. $3, 19$

Synthesis

To the student and the instructor: The Synthesis exercises found at the end of every exercise set challenge students to combine concepts or skills studied in that section or in preceding parts of the text.

Between any two (different) real numbers there are many other real numbers. Find each of the following. Answers may vary.

79. An irrational number between 0.124 and 0.125
 80. A rational number between $-\sqrt{2.01}$ and $-\sqrt{2}$
 81. A rational number between $-\frac{1}{101}$ and $-\frac{1}{100}$
 82. An irrational number between $\sqrt{5.99}$ and $\sqrt{6}$
 83. The hypotenuse of an isosceles right triangle with legs of length 1 unit can be used to “measure” a value for $\sqrt{2}$ by using the Pythagorean theorem, as shown.

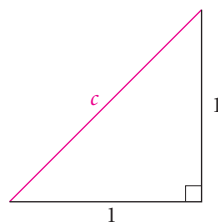

$$c^2 = 1^2 + 1^2$$

$$c^2 = 2$$

$$c = \sqrt{2}$$

Draw a right triangle that could be used to “measure” $\sqrt{10}$ units.

Integer Exponents, Scientific Notation, and Order of Operations

R.2

- ▶ Simplify expressions with integer exponents.
- ▶ Solve problems using scientific notation.
- ▶ Use the rules for order of operations.

▶ Integers as Exponents

When a positive integer is used as an *exponent*, it indicates the number of times a factor appears in a product. For example, 7^3 means $7 \cdot 7 \cdot 7$ and 5^1 means 5.

For any positive integer n ,

$$a^n = \underbrace{a \cdot a \cdot a \cdots a}_{n \text{ factors}}$$

where a is the **base** and n is the **exponent**.

Zero and negative-integer exponents are defined as follows.

For any nonzero real number a and any integer m ,

$$a^0 = 1 \quad \text{and} \quad a^{-m} = \frac{1}{a^m}.$$

EXAMPLE 1 Simplify each of the following.

a) 6^0 b) $(-3.4)^0$

Solution

a) $6^0 = 1$ b) $(-3.4)^0 = 1$

Now Try Exercise 7.

EXAMPLE 2 Write each of the following with positive exponents.

a) 4^{-5} b) $\frac{1}{(0.82)^{-7}}$ c) $\frac{x^{-3}}{y^{-8}}$

Solution

a) $4^{-5} = \frac{1}{4^5}$

b) $\frac{1}{(0.82)^{-7}} = (0.82)^{-(-7)} = (0.82)^7$

c) $\frac{x^{-3}}{y^{-8}} = x^{-3} \cdot \frac{1}{y^{-8}} = \frac{1}{x^3} \cdot y^8 = \frac{y^8}{x^3}$

Now Try Exercise 1.

The results in Example 2 can be generalized as follows.

For any nonzero numbers a and b and any integers m and n ,

$$\frac{a^{-m}}{b^{-n}} = \frac{b^n}{a^m}.$$

(A factor can be moved to the other side of the fraction bar if the sign of the exponent is changed.)

EXAMPLE 3 Write an equivalent expression without negative exponents:

$$\frac{x^{-3}y^{-8}}{z^{-10}}.$$

Solution Since each exponent is negative, we move each factor to the other side of the fraction bar and change the sign of each exponent:

$$\frac{x^{-3}y^{-8}}{z^{-10}} = \frac{z^{10}}{x^3y^8}.$$

 **Now Try Exercise 5.**

The following properties of exponents can be used to simplify expressions.

Properties of Exponents

For any real numbers a and b and any integers m and n , assuming 0 is not raised to a nonpositive power:

$$a^m \cdot a^n = a^{m+n} \quad \text{Product rule}$$

$$\frac{a^m}{a^n} = a^{m-n} \quad (a \neq 0) \quad \text{Quotient rule}$$

$$(a^m)^n = a^{mn} \quad \text{Power rule}$$

$$(ab)^m = a^m b^m \quad \text{Raising a product to a power}$$

$$\left(\frac{a}{b}\right)^m = \frac{a^m}{b^m} \quad (b \neq 0) \quad \text{Raising a quotient to a power}$$

EXAMPLE 4 Simplify each of the following.

- a) $y^{-5} \cdot y^3$ b) $\frac{48x^{12}}{16x^4}$ c) $(t^{-3})^5$
 d) $(2s^{-2})^5$ e) $\left(\frac{45x^{-4}y^2}{9z^{-8}}\right)^{-3}$

Solution

$$\text{a) } y^{-5} \cdot y^3 = y^{-5+3} = y^{-2}, \text{ or } \frac{1}{y^2}$$

$$\text{b) } \frac{48x^{12}}{16x^4} = \frac{48}{16}x^{12-4} = 3x^8$$

$$\text{c) } (t^{-3})^5 = t^{-3 \cdot 5} = t^{-15}, \text{ or } \frac{1}{t^{15}}$$

$$\text{d) } (2s^{-2})^5 = 2^5(s^{-2})^5 = 32s^{-10}, \text{ or } \frac{32}{s^{10}}$$

$$\begin{aligned} \text{e) } \left(\frac{45x^{-4}y^2}{9z^{-8}} \right)^{-3} &= \left(\frac{5x^{-4}y^2}{z^{-8}} \right)^{-3} \\ &= \frac{5^{-3}x^{12}y^{-6}}{z^{24}} = \frac{x^{12}}{5^3y^6z^{24}}, \text{ or } \frac{x^{12}}{125y^6z^{24}} \end{aligned}$$

➔ Now Try Exercises 15 and 39.

► Scientific Notation

We can use scientific notation to name very large and very small positive numbers and to perform computations.

Scientific Notation

Scientific notation for a number is an expression of the type

$$N \times 10^m,$$

where $1 \leq N < 10$, N is in decimal notation, and m is an integer.

Keep in mind that in scientific notation positive exponents are used for numbers greater than or equal to 10 and negative exponents for numbers between 0 and 1.



EXAMPLE 5 *Videos on Hulu.* The Web site Hulu.com, launched in 2008, offers videos of television shows and movies. In November 2009, less than 2 years after the launch, viewers watched about 923,800,000 shows and movies (*Source:* ComScore Media Matrix). Convert the number 923,800,000 to scientific notation.

Solution We want the decimal point to be positioned between the 9 and the 2, so we move it 8 places to the left. Since the number to be converted is greater than 10, the exponent must be positive. Thus we have

$$923,800,000 = 9.238 \times 10^8.$$

➔ Now Try Exercise 51.

EXAMPLE 6 *Volume Conversion.*

One cubic inch is approximately equal to 0.000016 m^3 . Convert 0.000016 to scientific notation.

Solution We want the decimal point to be positioned between the 1 and the 6, so we move it 5 places to the right. Since the number to be converted is between 0 and 1, the exponent must be negative. Thus we have

$$0.000016 = 1.6 \times 10^{-5}.$$

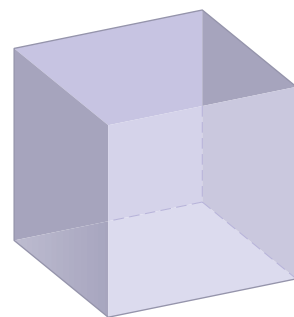

➔ Now Try Exercise 59.

EXAMPLE 7 Convert each of the following to decimal notation.

a) 7.632×10^{-4}

b) 9.4×10^5

Solution

a) The exponent is negative, so the number is between 0 and 1. We move the decimal point 4 places to the left.

$$7.632 \times 10^{-4} = 0.0007632$$

b) The exponent is positive, so the number is greater than 10. We move the decimal point 5 places to the right.

$$9.4 \times 10^5 = 940,000$$

➔ **Now Try Exercises 61 and 63.**

TECHNOLOGY CONNECTION

Most calculators make use of scientific notation. For example, the number 48,000,000,000,000 might be expressed as shown below.

4.8E13

The computation in Example 8 can be performed on a calculator using scientific notation.

9.3E7*3.01E1

2.7993E9

EXAMPLE 8 *Distance to Neptune.* The distance from Earth to the sun is defined as **1 astronomical unit**, or AU. It is about 93 million mi. The average distance from Earth to Neptune is 30.1 AUs (*Source:* Astronomy Department, Cornell University). How many miles is it from Earth to Neptune? Express your answer in scientific notation.

Solution First, we convert each number to scientific notation:

$$93 \text{ million} = 93,000,000 = 9.3 \times 10^7;$$

$$30.1 = 3.01 \times 10^1, \text{ or } 3.01 \times 10.$$

Now we multiply:

$$\begin{aligned} (9.3 \times 10^7)(3.01 \times 10) &= (9.3 \times 3.01) \times (10^7 \times 10) \\ &= 27.993 \times 10^8 \end{aligned}$$

This is not scientific notation because $27.993 > 10$.

$$= (2.7993 \times 10) \times 10^8$$

$$= 2.7993 \times (10 \times 10^8)$$

$$= 2.7993 \times 10^9 \text{ mi.}$$

Writing scientific notation

➔ **Now Try Exercise 79.**

► Order of Operations

Recall that to simplify the expression $3 + 4 \cdot 5$, we first multiply 4 and 5 to get 20 and then add 3 to get 23. Mathematicians have agreed on the following procedure, or rules for order of operations.

Rules for Order of Operations

1. Do all calculations within grouping symbols before operations outside. When nested grouping symbols are present, work from the inside out.
2. Evaluate all exponential expressions.
3. Do all multiplications and divisions in order from left to right.
4. Do all additions and subtractions in order from left to right.

TECHNOLOGY CONNECTION

Enter the computations in Example 9 on a graphing calculator as shown below. (The display will look somewhat different if your calculator's operating system includes MathPrint.)

$8(5-3)^3-20$	44
$(10/(8-6)+9*4)/(2^5+3^2)$	1

To confirm that the parentheses around the numerator and around the denominator are essential in Example 9(b), enter the computation without using these parentheses. Note that the result is 15.125 rather than 1.

TECHNOLOGY CONNECTION

The TVM Solver option in the Finance APP on a graphing calculator can be used to do Example 10.

N=32
I%=4.6
PV=-1250
PMT=0
FV=1802.263969
P/Y=4
C/Y=4
PMT: END BEGIN

EXAMPLE 9 Calculate each of the following.

a) $8(5 - 3)^3 - 20$

b) $\frac{10 \div (8 - 6) + 9 \cdot 4}{2^5 + 3^2}$

Solution

a) $8(5 - 3)^3 - 20 = 8 \cdot 2^3 - 20$ **Doing the calculation within parentheses**
 $= 8 \cdot 8 - 20$ **Evaluating the exponential expression**
 $= 64 - 20$ **Multiplying**
 $= 44$ **Subtracting**

b) $\frac{10 \div (8 - 6) + 9 \cdot 4}{2^5 + 3^2} = \frac{10 \div 2 + 9 \cdot 4}{32 + 9}$
 $= \frac{5 + 36}{41} = \frac{41}{41} = 1$

Note that fraction bars act as grouping symbols. That is, the given expression is equivalent to $[10 \div (8 - 6) + 9 \cdot 4] \div (2^5 + 3^2)$.

 **Now Try Exercises 87 and 91.**

EXAMPLE 10 Compound Interest. If a principal P is invested at an interest rate r , compounded n times per year, in t years it will grow to an amount A given by

$$A = P \left(1 + \frac{r}{n} \right)^{nt}$$

Suppose that \$1250 is invested at 4.6% interest, compounded quarterly. How much is in the account at the end of 8 years?

Solution We have $P = 1250$, $r = 4.6\%$, or 0.046, $n = 4$, and $t = 8$. Substituting, we find that the amount in the account at the end of 8 years is given by

$$A = 1250 \left(1 + \frac{0.046}{4} \right)^{4 \cdot 8}$$

Next, we evaluate this expression:

$$\begin{aligned} A &= 1250(1 + 0.0115)^{4 \cdot 8} && \text{Dividing inside the parentheses} \\ &= 1250(1.0115)^{4 \cdot 8} && \text{Adding inside the parentheses} \\ &= 1250(1.0115)^{32} && \text{Multiplying in the exponent} \\ &\approx 1250(1.441811175) && \text{Evaluating the exponential expression} \\ &\approx 1802.263969 && \text{Multiplying} \\ &\approx 1802.26 && \text{Rounding to the nearest cent} \end{aligned}$$

The amount in the account at the end of 8 years is \$1802.26.

 **Now Try Exercise 93.**

R.2

Exercise Set

Write an equivalent expression without negative exponents.

1. 3^{-7}

3. $\frac{x^{-5}}{y^{-4}}$

5. $\frac{m^{-1}n^{-12}}{t^{-6}}$

2. $\frac{1}{(5.9)^{-4}}$

4. $\frac{a^{-2}}{b^{-8}}$

6. $\frac{x^{-9}y^{-17}}{z^{-11}}$

Simplify.

7. 23^0

9. $z^0 \cdot z^7$

11. $5^8 \cdot 5^{-6}$

13. $m^{-5} \cdot m^5$

15. $y^3 \cdot y^{-7}$

17. $(x+3)^4(x+3)^{-2}$

19. $3^{-3} \cdot 3^8 \cdot 3$

21. $2x^3 \cdot 3x^2$

23. $(-3a^{-5})(5a^{-7})$

25. $(6x^{-3}y^5)(-7x^2y^{-9})$

27. $(2x)^4(3x)^3$

29. $(-2n)^3(5n)^2$

31. $\frac{y^{35}}{y^{31}}$

33. $\frac{b^{-7}}{b^{12}}$

35. $\frac{x^2y^{-2}}{x^{-1}y}$

37. $\frac{32x^{-4}y^3}{4x^{-5}y^8}$

8. $\left(-\frac{2}{5}\right)^0$

10. $x^{10} \cdot x^0$

12. $6^2 \cdot 6^{-7}$

14. $n^9 \cdot n^{-9}$

16. $b^{-4} \cdot b^{12}$

18. $(y-1)^{-1}(y-1)^5$

20. $6^7 \cdot 6^{-10} \cdot 6^2$

22. $3y^4 \cdot 4y^3$

24. $(-6b^{-4})(2b^{-7})$

26. $(8ab^7)(-7a^{-5}b^2)$

28. $(4y)^2(3y)^3$

30. $(2x)^5(3x)^2$

32. $\frac{x^{26}}{x^{13}}$

34. $\frac{a^{-18}}{a^{-13}}$

36. $\frac{x^3y^{-3}}{x^{-1}y^2}$

38. $\frac{20a^5b^{-2}}{5a^7b^{-3}}$

39. $(2x^2y)^4$

41. $(-2x^3)^5$

43. $(-5c^{-1}d^{-2})^{-2}$

45. $(3m^4)^3(2m^{-5})^4$

47. $\left(\frac{2x^{-3}y^7}{z^{-1}}\right)^3$

49. $\left(\frac{24a^{10}b^{-8}c^7}{12a^6b^{-3}c^5}\right)^{-5}$

50. $\left(\frac{125p^{12}q^{-14}r^{22}}{25p^8q^6r^{-15}}\right)^{-4}$

40. $(3ab^5)^3$

42. $(-3x^2)^4$

44. $(-4x^{-5}z^{-2})^{-3}$

46. $(4n^{-1})^2(2n^3)^3$

48. $\left(\frac{3x^5y^{-8}}{z^{-2}}\right)^4$

Convert to scientific notation.

51. 16,500,000

52. 359,000

53. 0.000000437

54. 0.0056

55. 234,600,000,000

56. 8,904,000,000

57. 0.00104

58. 0.0000000514

59. *Mass of a Neutron.* The mass of a neutron is about 0.0000000000000000000000167 kg.

60. *Tech Security Spending.* It is estimated that \$37,800,000,000 will be spent on information technology security systems in 2013 (Source: IDC).

Convert to decimal notation.

61. 7.6×10^5

62. 3.4×10^{-6}

63. 1.09×10^{-7}

64. 5.87×10^8

65. 3.496×10^{10}

66. 8.409×10^{11}

67. 5.41×10^{-8}

68. 6.27×10^{-10}

69. The amount of solid waste generated in the United States in a recent year was 2.319×10^8 tons (Source: Franklin Associates, Ltd.).

70. The mass of a proton is about 1.67×10^{-24} g.

Compute. Write the answer using scientific notation.

71. $(4.2 \times 10^7)(3.2 \times 10^{-2})$

72. $(8.3 \times 10^{-15})(7.7 \times 10^4)$

73. $(2.6 \times 10^{-18})(8.5 \times 10^7)$

74. $(6.4 \times 10^{12})(3.7 \times 10^{-5})$

75. $\frac{6.4 \times 10^{-7}}{8.0 \times 10^6}$

76. $\frac{1.1 \times 10^{-40}}{2.0 \times 10^{-71}}$

77. $\frac{1.8 \times 10^{-3}}{7.2 \times 10^{-9}}$

78. $\frac{1.3 \times 10^4}{5.2 \times 10^{10}}$

Solve. Write the answer using scientific notation.

79. **Trash on U.S. Roadways.** It is estimated that there were 51.2 billion pieces of trash on 76 million mi of U.S. roadways in a recent year (Source: Keep America Beautiful). On average, how many pieces of trash were on each mile of roadway?



80. **Nanowires.** A **nanometer** is 0.000000001 m. Scientists have developed optical nanowires to transmit light waves short distances. A nanowire with a diameter of 360 nanometers has been used in experiments on the transmission of light (Source: *The New York Times*, January 29, 2004). Find the diameter of such a wire in meters.
81. **Population Density.** The tiny country of Monaco has an area of 0.75 mi^2 . It is estimated that the population of Monaco will be 38,000 in 2050. Find the number of people per square mile in 2050.

82. **Chesapeake Bay Bridge-Tunnel.** The 17.6-mi long Chesapeake Bay Bridge-Tunnel was completed in 1964. Construction costs were \$210 million. Find the average cost per mile.

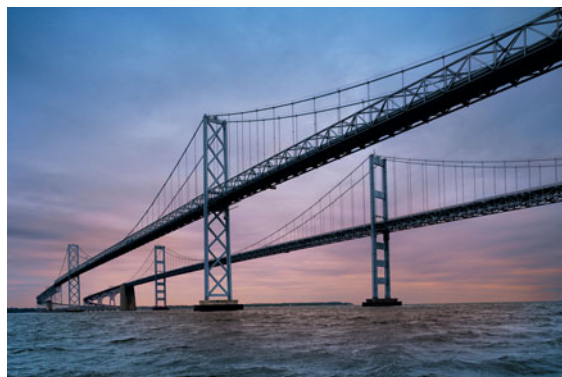

83. **Distance to a Star.** The nearest star, Alpha Centauri C, is about 4.22 light-years from Earth. One **light-year** is the distance that light travels in one year and is about 5.88×10^{12} mi. How many miles is it from Earth to Alpha Centauri C?
84. **Parsecs.** One **parsec** is about 3.26 light-years and 1 light-year is about 5.88×10^{12} mi. Find the number of miles in 1 parsec.
85. **Nuclear Disintegration.** One gram of radium produces 37 billion disintegrations per second. How many disintegrations are produced in 1 hr?
86. **Length of Earth's Orbit.** The average distance from Earth to the sun is 93 million mi. About how far does Earth travel in a yearly orbit? (Assume a circular orbit.)

Calculate.

87. $5 \cdot 3 + 8 \cdot 3^2 + 4(6 - 2)$

88. $5[3 - 8 \cdot 3^2 + 4 \cdot 6 - 2]$

89. $16 \div 4 \cdot 4 \div 2 \cdot 256$

90. $2^6 \cdot 2^{-3} \div 2^{10} \div 2^{-8}$

91. $\frac{4(8 - 6)^2 - 4 \cdot 3 + 2 \cdot 8}{3^1 + 19^0}$

$$92. \frac{[4(8 - 6)^2 + 4](3 - 2 \cdot 8)}{2^2(2^3 + 5)}$$

Compound Interest. Use the compound interest formula from Example 10 for Exercises 93–96. Round to the nearest cent.

93. Suppose that \$3225 is invested at 3.1%, compounded semiannually. How much is in the account at the end of 4 years?
94. Suppose that \$7550 is invested at 2.8%, compounded semiannually. How much is in the account at the end of 5 years?
95. Suppose that \$4100 is invested at 2.3%, compounded quarterly. How much is in the account at the end of 6 years?
96. Suppose that \$4875 is invested at 1.8%, compounded quarterly. How much is in the account at the end of 9 years?

Synthesis

Savings Plan. The formula

$$S = P \left[\frac{\left(1 + \frac{r}{12}\right)^{12t} - 1}{\frac{r}{12}} \right]$$

gives the amount S accumulated in a savings plan when a deposit of P dollars is made each month for t years in an account with interest rate r , compounded monthly. Use this formula for Exercises 97–100.

97. James deposits \$250 in a retirement account each month beginning at age 40. If the investment earns 5% interest, compounded monthly, how much will have accumulated in the account when he retires 27 years later?
98. Kayla deposits \$100 in a retirement account each month beginning at age 25. If the investment earns 4% interest, compounded monthly, how much will have accumulated in the account when she retires at age 65?

99. Sue and Richard want to establish a college fund for their daughter that will have accumulated \$120,000 at the end of 18 years. If they can count on an interest rate of 3%, compounded monthly, how much should they deposit each month to accomplish this?



100. Lamont wants to have \$200,000 accumulated in a retirement account by age 70. If he starts making monthly deposits to the plan at age 30 and can count on an interest rate of 4.5%, compounded monthly, how much should he deposit each month in order to accomplish this?

Simplify. Assume that all exponents are integers, all denominators are nonzero, and zero is not raised to a nonpositive power.

101. $(x^t \cdot x^{3t})^2$
102. $(x^y \cdot x^{-y})^3$
103. $(t^{a+x} \cdot t^{x-a})^4$
104. $(m^{x-b} \cdot n^{x+b})^x (m^b n^{-b})^x$
105. $\left[\frac{(3x^a y^b)^3}{(-3x^a y^b)^2} \right]^2$
106. $\left[\left(\frac{x^r}{y^t} \right)^2 \left(\frac{x^{2r}}{y^{4t}} \right)^{-2} \right]^{-3}$

Addition, Subtraction, and Multiplication of Polynomials

R.3

- ▶ Identify the terms, the coefficients, and the degree of a polynomial.
- ▶ Add, subtract, and multiply polynomials.

▶ Polynomials

Polynomials are a type of algebraic expression that you will often encounter in your study of algebra. Some examples of polynomials are

$$3x - 4y, \quad 5y^3 - \frac{7}{3}y^2 + 3y - 2, \quad -2.3a^4, \quad \text{and} \quad z^6 - \sqrt{5}.$$

All but the first are polynomials in one variable.

Polynomials in One Variable

A **polynomial in one variable** is any expression of the type

$$a_n x^n + a_{n-1} x^{n-1} + \cdots + a_2 x^2 + a_1 x + a_0,$$

where n is a nonnegative integer and a_n, \dots, a_0 are real numbers, called **coefficients**. The parts of a polynomial separated by plus signs are called **terms**. The **leading coefficient** is a_n , and the **constant term** is a_0 . If $a_n \neq 0$, the **degree** of the polynomial is n . The polynomial is said to be written in **descending order**, because the exponents decrease from left to right.

EXAMPLE 1 Identify the terms of the polynomial

$$2x^4 - 7.5x^3 + x - 12.$$

Solution Writing plus signs between the terms, we have

$$2x^4 - 7.5x^3 + x - 12 = 2x^4 + (-7.5x^3) + x + (-12),$$

so the terms are

$$2x^4, \quad -7.5x^3, \quad x, \quad \text{and} \quad -12. \quad \leftarrow$$

A polynomial, consisting of only a nonzero constant term like 23, has degree 0. It is agreed that the polynomial consisting only of 0 has *no* degree.

EXAMPLE 2 Find the degree of each polynomial.

- a) $2x^3 - 9$
 b) $y^2 - \frac{3}{2} + 5y^4$
 c) 7

Solution

POLYNOMIAL	DEGREE
a) $2x^3 - 9$	3
b) $y^2 - \frac{3}{2} + 5y^4 = 5y^4 + y^2 - \frac{3}{2}$	4
c) $7 = 7x^0$	0

 **Now Try Exercise 1.**

Algebraic expressions like $3ab^3 - 8$ and $5x^4y^2 - 3x^3y^8 + 7xy^2 + 6$ are **polynomials in several variables**. The **degree of a term** is the sum of the exponents of the variables in that term. The **degree of a polynomial** is the degree of the term of highest degree.

EXAMPLE 3 Find the degree of the polynomial

$$7ab^3 - 11a^2b^4 + 8.$$

Solution The degrees of the terms of $7ab^3 - 11a^2b^4 + 8$ are 4, 6, and 0, respectively, so the degree of the polynomial is 6.  **Now Try Exercise 3.**

A polynomial with just one term, like $-9y^6$, is a **monomial**. If a polynomial has two terms, like $x^2 + 4$, it is a **binomial**. A polynomial with three terms, like $4x^2 - 4xy + 1$, is a **trinomial**.

Expressions like

$$2x^2 - 5x + \frac{3}{x}, \quad 9 - \sqrt{x}, \quad \text{and} \quad \frac{x+1}{x^4+5}$$

are not polynomials, because they cannot be written in the form $a_nx^n + a_{n-1}x^{n-1} + \cdots + a_1x + a_0$, where the exponents are all nonnegative integers and the coefficients are all real numbers.

► Addition and Subtraction

If two terms of an expression have the same variables raised to the same powers, they are called **like terms**, or **similar terms**. We can **combine**, or **collect, like terms** using the distributive property. For example, $3y^2$ and $5y^2$ are like terms and

$$\begin{aligned} 3y^2 + 5y^2 &= (3 + 5)y^2 \\ &= 8y^2. \end{aligned}$$

We add or subtract polynomials by combining like terms.

EXAMPLE 4 Add or subtract each of the following.

a) $(-5x^3 + 3x^2 - x) + (12x^3 - 7x^2 + 3)$

b) $(6x^2y^3 - 9xy) - (5x^2y^3 - 4xy)$

Solution

a) $(-5x^3 + 3x^2 - x) + (12x^3 - 7x^2 + 3)$
 $= (-5x^3 + 12x^3) + (3x^2 - 7x^2) - x + 3$

Rearranging using the commutative and associative properties

$$= (-5 + 12)x^3 + (3 - 7)x^2 - x + 3$$

Using the distributive property

$$= 7x^3 - 4x^2 - x + 3$$

b) We can subtract by adding an opposite:

$$(6x^2y^3 - 9xy) - (5x^2y^3 - 4xy)$$

$$= (6x^2y^3 - 9xy) + (-5x^2y^3 + 4xy)$$

Adding the opposite of $5x^2y^3 - 4xy$

$$= 6x^2y^3 - 9xy - 5x^2y^3 + 4xy$$

$$= x^2y^3 - 5xy.$$

Combining like terms

➔ Now Try Exercises 5 and 9.

► Multiplication

To multiply monomials, we first multiply their coefficients, and then we multiply their variables.

EXAMPLE 5 Multiply each of the following.

a) $(-2x^3)(5x^4)$

b) $(3yz^2)(8y^3z^5)$

Solution

a) $(-2x^3)(5x^4) = (-2 \cdot 5)(x^3 \cdot x^4) = -10x^7$

b) $(3yz^2)(8y^3z^5) = (3 \cdot 8)(y \cdot y^3)(z^2 \cdot z^5) = 24y^4z^7$

➔ Now Try Exercises 13 and 15.

Multiplication of polynomials other than monomials is based on the distributive property—for example,

$$(x + 4)(x + 3) = x(x + 3) + 4(x + 3)$$

Using the distributive property

$$= x^2 + 3x + 4x + 12$$

Using the distributive property two more times

$$= x^2 + 7x + 12.$$

Combining like terms

In general, to multiply two polynomials, we multiply each term of one by each term of the other and add the products.

EXAMPLE 6 Multiply: $(4x^4y - 7x^2y + 3y)(2y - 3x^2y)$.

Solution We have

$$\begin{aligned}
 &(4x^4y - 7x^2y + 3y)(2y - 3x^2y) \\
 &= 4x^4y(2y - 3x^2y) - 7x^2y(2y - 3x^2y) + 3y(2y - 3x^2y) && \text{Using the distributive property} \\
 &= 8x^4y^2 - 12x^6y^2 - 14x^2y^2 + 21x^4y^2 + 6y^2 - 9x^2y^2 && \text{Using the distributive property three more times} \\
 &= 29x^4y^2 - 12x^6y^2 - 23x^2y^2 + 6y^2. && \text{Combining like terms}
 \end{aligned}$$

We can also use columns to organize our work, aligning like terms under each other in the products.

$$\begin{array}{r}
 4x^4y - 7x^2y + 3y \\
 2y - 3x^2y \\
 \hline
 -12x^6y^2 + 21x^4y^2 - 9x^2y^2 \\
 8x^4y^2 - 14x^2y^2 + 6y^2 \\
 \hline
 -12x^6y^2 + 29x^4y^2 - 23x^2y^2 + 6y^2
 \end{array}$$

Multiplying by $-3x^2y$
 Multiplying by $2y$
 Adding

 **Now Try Exercise 17.**

We can find the product of two binomials by multiplying the **F**irst terms, then the **O**uter terms, then the **I**nner terms, and then the **L**ast terms. Then we combine like terms, if possible. This procedure is sometimes called **FOIL**.

EXAMPLE 7 Multiply: $(2x - 7)(3x + 4)$.

Solution We have

$$\begin{array}{c}
 \text{F} \qquad \qquad \text{L} \\
 \text{O} \qquad \qquad \text{I} \\
 \text{I} \qquad \qquad \text{O}
 \end{array}
 \quad
 \begin{array}{c}
 \text{F} \quad \text{O} \quad \text{I} \quad \text{L} \\
 (2x - 7)(3x + 4) = 6x^2 + 8x - 21x - 28 \\
 = 6x^2 - 13x - 28.
 \end{array}$$

 **Now Try Exercise 19.**

We can use FOIL to find some special products.

Special Products of Binomials

$(A + B)^2 = A^2 + 2AB + B^2$	Square of a sum
$(A - B)^2 = A^2 - 2AB + B^2$	Square of a difference
$(A + B)(A - B) = A^2 - B^2$	Product of a sum and a difference

EXAMPLE 8 Multiply each of the following.

a) $(4x + 1)^2$ b) $(3y^2 - 2)^2$ c) $(x^2 + 3y)(x^2 - 3y)$

Solution

a) $(4x + 1)^2 = (4x)^2 + 2 \cdot 4x \cdot 1 + 1^2 = 16x^2 + 8x + 1$

b) $(3y^2 - 2)^2 = (3y^2)^2 - 2 \cdot 3y^2 \cdot 2 + 2^2 = 9y^4 - 12y^2 + 4$

c) $(x^2 + 3y)(x^2 - 3y) = (x^2)^2 - (3y)^2 = x^4 - 9y^2$

 Now Try Exercises 27 and 37.

Division of polynomials is discussed in Section 4.3.

R.3

Exercise Set

Determine the terms and the degree of the polynomial.

1. $7x^3 - 4x^2 + 8x + 5$

2. $-3n^4 - 6n^3 + n^2 + 2n - 1$

3. $3a^4b - 7a^3b^3 + 5ab - 2$

4. $6p^3q^2 - p^2q^4 - 3pq^2 + 5$

Perform the indicated operations.

5. $(3ab^2 - 4a^2b - 2ab + 6) + (-ab^2 - 5a^2b + 8ab + 4)$

6. $(-6m^2n + 3mn^2 - 5mn + 2) + (4m^2n + 2mn^2 - 6mn - 9)$

7. $(2x + 3y + z - 7) + (4x - 2y - z + 8) + (-3x + y - 2z - 4)$

8. $(2x^2 + 12xy - 11) + (6x^2 - 2x + 4) + (-x^2 - y - 2)$

9. $(3x^2 - 2x - x^3 + 2) - (5x^2 - 8x - x^3 + 4)$

10. $(5x^2 + 4xy - 3y^2 + 2) - (9x^2 - 4xy + 2y^2 - 1)$

11. $(x^4 - 3x^2 + 4x) - (3x^3 + x^2 - 5x + 3)$

12. $(2x^4 - 3x^2 + 7x) - (5x^3 + 2x^2 - 3x + 5)$

13. $(3a^2)(-7a^4)$

14. $(8y^5)(9y)$

15. $(6xy^3)(9x^4y^2)$

16. $(-5m^4n^2)(6m^2n^3)$

17. $(a - b)(2a^3 - ab + 3b^2)$

18. $(n + 1)(n^2 - 6n - 4)$

19. $(y - 3)(y + 5)$

20. $(z + 4)(z - 2)$

21. $(x + 6)(x + 3)$

22. $(a - 8)(a - 1)$

23. $(2a + 3)(a + 5)$

24. $(3b + 1)(b - 2)$

25. $(2x + 3y)(2x + y)$

26. $(2a - 3b)(2a - b)$

27. $(x + 3)^2$

28. $(z + 6)^2$

29. $(y - 5)^2$

30. $(x - 4)^2$

31. $(5x - 3)^2$

32. $(3x - 2)^2$

33. $(2x + 3y)^2$

34. $(5x + 2y)^2$

35. $(2x^2 - 3y)^2$

36. $(4x^2 - 5y)^2$

37. $(n + 6)(n - 6)$

38. $(m + 1)(m - 1)$

39. $(3y + 4)(3y - 4)$

40. $(2x - 7)(2x + 7)$

41. $(3x - 2y)(3x + 2y)$

42. $(3x + 5y)(3x - 5y)$

43. $(2x + 3y + 4)(2x + 3y - 4)$

44. $(5x + 2y + 3)(5x + 2y - 3)$

45. $(x + 1)(x - 1)(x^2 + 1)$

46. $(y - 2)(y + 2)(y^2 + 4)$

Synthesis

Multiply. Assume that all exponents are natural numbers.

47. $(a^n + b^n)(a^n - b^n)$

48. $(t^a + 4)(t^a - 7)$

49. $(a^n + b^n)^2$

50. $(x^{3m} - t^{5n})^2$

51. $(x - 1)(x^2 + x + 1)(x^3 + 1)$

52. $[(2x - 1)^2 - 1]^2$

53. $(x^{a-b})^{a+b}$

54. $(t^{m+n})^{m+n} \cdot (t^{m-n})^{m-n}$

55. $(a + b + c)^2$

Factoring

R.4

- ▶ Factor polynomials by removing a common factor.
- ▶ Factor polynomials by grouping.
- ▶ Factor trinomials of the type $x^2 + bx + c$.
- ▶ Factor trinomials of the type $ax^2 + bx + c$, $a \neq 1$, using the FOIL method and the grouping method.
- ▶ Factor special products of polynomials.

To factor a polynomial, we do the reverse of multiplying; that is, we find an equivalent expression that is written as a product.

▶ Terms with Common Factors

When a polynomial is to be factored, we should always look first to factor out a factor that is common to all the terms using the distributive property. We generally look for the constant common factor with the largest absolute value and for variables with the largest exponent common to all the terms. In this sense, we factor out the “largest” common factor.

EXAMPLE 1 Factor each of the following.

a) $15 + 10x - 5x^2$

b) $12x^2y^2 - 20x^3y$

Solution

a) $15 + 10x - 5x^2 = 5 \cdot 3 + 5 \cdot 2x - 5 \cdot x^2 = 5(3 + 2x - x^2)$

We can always check a factorization by multiplying:

$$5(3 + 2x - x^2) = 15 + 10x - 5x^2.$$

b) There are several factors common to the terms of $12x^2y^2 - 20x^3y$, but $4x^2y$ is the “largest” of these.

$$\begin{aligned} 12x^2y^2 - 20x^3y &= 4x^2y \cdot 3y - 4x^2y \cdot 5x \\ &= 4x^2y(3y - 5x) \end{aligned}$$

➔ Now Try Exercise 3.

► Factoring by Grouping

In some polynomials, pairs of terms have a common binomial factor that can be removed in a process called **factoring by grouping**.

EXAMPLE 2 Factor: $x^3 + 3x^2 - 5x - 15$.

Solution We have

$$\begin{aligned} x^3 + 3x^2 - 5x - 15 &= (x^3 + 3x^2) + (-5x - 15) \\ &= x^2(x + 3) - 5(x + 3) \\ &= (x + 3)(x^2 - 5). \end{aligned}$$

Grouping. Each group of terms has a common factor.

Factoring a common factor out of each group

Factoring out the common binomial factor

➔ Now Try Exercise 9.

► Trinomials of the Type $x^2 + bx + c$

Some trinomials can be factored into the product of two binomials. To factor a trinomial of the form $x^2 + bx + c$, we look for binomial factors of the form

$$(x + p)(x + q),$$

where $p \cdot q = c$ and $p + q = b$. That is, we look for two numbers p and q whose sum is the coefficient of the middle term of the polynomial, b , and whose product is the constant term, c .

When we factor any polynomial, we should always check first to determine whether there is a factor common to all the terms. If there is, we factor it out first.

EXAMPLE 3 Factor: $x^2 + 5x + 6$.

Solution First, we look for a common factor. There is none. Next, we look for two numbers whose product is 6 and whose sum is 5. Since the constant term, 6, and the coefficient of the middle term, 5, are both positive, we look for a factorization of 6 in which both factors are positive.

Pairs of Factors	Sums of Factors
1, 6	7
2, 3	5 ←

The numbers we need are 2 and 3.

The factorization is $(x + 2)(x + 3)$. We have

$$x^2 + 5x + 6 = (x + 2)(x + 3).$$

We can check this by multiplying:

$$(x + 2)(x + 3) = x^2 + 3x + 2x + 6 = x^2 + 5x + 6.$$

 **Now Try Exercise 21.**

EXAMPLE 4 Factor: $x^4 - 6x^3 + 8x^2$.

Solution First, we look for a common factor. Each term has a factor of x^2 , so we factor it out first:

$$x^4 - 6x^3 + 8x^2 = x^2(x^2 - 6x + 8).$$

Now we consider the trinomial $x^2 - 6x + 8$. We look for two numbers whose product is 8 and whose sum is -6 . Since the constant term, 8, is positive and the coefficient of the middle term, -6 , is negative, we look for a factorization of 8 in which both factors are negative.

Pairs of Factors	Sums of Factors
$-1, -8$	-9
$-2, -4$	-6

The numbers we need are -2 and -4 .

The factorization of $x^2 - 6x + 8$ is $(x - 2)(x - 4)$. We must also include the common factor that we factored out earlier. Thus we have

$$x^4 - 6x^3 + 8x^2 = x^2(x - 2)(x - 4).$$

 **Now Try Exercise 31.**

EXAMPLE 5 Factor: $x^2 + xy - 12y^2$.

Solution Having checked for a common factor and found none, we think much the same way as if we were factoring $x^2 + x - 12$. We look for factors of -12 whose sum is the coefficient of the xy -term, 1. Since the last term, $-12y^2$, is negative, one factor will be positive and the other will be negative.

Pairs of Factors	Sums of Factors
$-1, 12$	11
$1, -12$	-11
$-2, 6$	4
$2, -6$	-4
$-3, 4$	1
$3, -4$	-1

The numbers we need are -3 and 4 .

We might have observed at the outset that since the sum of the factors must be 1, a positive number, we need consider only pairs of factors for which the positive factor has the greater absolute value. Thus only the pairs -1 and 12 , -2 and 6 , -3 and 4 need have been considered.

The factorization is

$$(x - 3y)(x + 4y).$$

 **Now Try Exercise 25.**

► Trinomials of the Type $ax^2 + bx + c, a \neq 1$

We consider two methods for factoring trinomials of the type $ax^2 + bx + c, a \neq 1$.

The FOIL Method

We first consider the **FOIL method** for factoring trinomials of the type $ax^2 + bx + c, a \neq 1$. Consider the following multiplication.

$$\begin{array}{ccccccc} & & \text{F} & & \text{O} & \text{I} & \text{L} \\ & & \downarrow & & \downarrow & \downarrow & \downarrow \\ (3x + 2)(4x + 5) & = & 12x^2 & + & 15x & + & 8x & + & 10 \\ & & \downarrow & & \downarrow & & \downarrow & & \\ & & 12x^2 & + & 23x & + & 10 & & \end{array}$$

To factor $12x^2 + 23x + 10$, we must reverse what we just did. We look for two binomials whose product is this trinomial. The product of the **First** terms must be $12x^2$. The product of the **Outer** terms plus the product of the **Inner** terms must be $23x$. The product of the **Last** terms must be 10 . We know from the preceding discussion that the answer is $(3x + 2)(4x + 5)$. In general, however, finding such an answer involves trial and error. We use the following method.

To factor trinomials of the type $ax^2 + bx + c, a \neq 1$, using the **FOIL method**:

- Factor out the largest common factor.
- Find two First terms whose product is ax^2 :

$$\begin{array}{ccccccc} (\square x + \square) & (\square x + \square) & = & ax^2 & + & bx & + & c. \\ & \underbrace{\hspace{1.5cm}} & & \text{FOIL} & & & & \end{array}$$

- Find two Last terms whose product is c :

$$\begin{array}{ccccccc} (\square x + \square) & (\square x + \square) & = & ax^2 & + & bx & + & c. \\ & \underbrace{\hspace{1.5cm}} & & \text{FOIL} & & & & \end{array}$$

- Repeat steps (2) and (3) until a combination is found for which the sum of the Outer product and the Inner product is bx :

$$\begin{array}{ccccccc} (\square x + \square) & (\square x + \square) & = & ax^2 & + & bx & + & c. \\ & \underbrace{\hspace{1.5cm}} & \underbrace{\hspace{1.5cm}} & & & \text{FOIL} & & \\ & \underbrace{\hspace{1.5cm}} & \underbrace{\hspace{1.5cm}} & & & & & \\ & \text{O} & \text{I} & & & & & \end{array}$$

EXAMPLE 6 Factor: $3x^2 - 10x - 8$.

Solution

1. There is no common factor (other than 1 or -1).
2. Factor the first term, $3x^2$. The only possibility (with positive integer coefficients) is $3x \cdot x$. The factorization, if it exists, must be of the form $(3x + \square)(x + \square)$.
3. Next, factor the constant term, -8 . The possibilities are $-8(1)$, $8(-1)$, $-2(4)$, and $2(-4)$. The factors can be written in the opposite order as well: $1(-8)$, $-1(8)$, $4(-2)$, and $-4(2)$.
4. Find a pair of factors for which the sum of the outer product and the inner product is the middle term, $-10x$. Each possibility should be checked by multiplying. Some trials show that the desired factorization is $(3x + 2)(x - 4)$.

 **Now Try Exercise 35.**

The Grouping Method

The second method for factoring trinomials of the type $ax^2 + bx + c$, $a \neq 1$, is known as the **grouping method**, or the **ac -method**.

To factor $ax^2 + bx + c$, $a \neq 1$, using the **grouping method**:

1. Factor out the largest common factor.
2. Multiply the leading coefficient a and the constant c .
3. Try to factor the product ac so that the sum of the factors is b . That is, find integers p and q such that $pq = ac$ and $p + q = b$.
4. Split the middle term. That is, write it as a sum using the factors found in step (3).
5. Factor by grouping.

EXAMPLE 7 Factor: $12x^3 + 10x^2 - 8x$.

Solution

1. Factor out the largest common factor, $2x$:

$$12x^3 + 10x^2 - 8x = 2x(6x^2 + 5x - 4).$$

2. Now consider $6x^2 + 5x - 4$. Multiply the leading coefficient, 6, and the constant, -4 : $6(-4) = -24$.

3. Try to factor -24 so that the sum of the factors is the coefficient of the middle term, 5.

Pairs of Factors	Sums of Factors
1, -24	-23
-1 , 24	23
2, -12	-10
-2 , 12	10
3, -8	-5
-3 , 8	5 ← $-3 \cdot 8 = -24; -3 + 8 = 5$
4, -6	-2
-4 , 6	2

4. Split the middle term using the numbers found in step (3):

$$5x = -3x + 8x.$$

5. Finally, factor by grouping:

$$\begin{aligned} 6x^2 + 5x - 4 &= 6x^2 - 3x + 8x - 4 \\ &= 3x(2x - 1) + 4(2x - 1) \\ &= (2x - 1)(3x + 4). \end{aligned}$$

Be sure to include the common factor to get the complete factorization of the original trinomial:

$$12x^3 + 10x^2 - 8x = 2x(2x - 1)(3x + 4).$$

 Now Try Exercise 45.

► Special Factorizations

We reverse the equation $(A + B)(A - B) = A^2 - B^2$ to factor a **difference of squares**.

$$A^2 - B^2 = (A + B)(A - B)$$

EXAMPLE 8 Factor each of the following.

a) $x^2 - 16$

b) $9a^2 - 25$

c) $6x^4 - 6y^4$

Solution

a) $x^2 - 16 = x^2 - 4^2 = (x + 4)(x - 4)$

b) $9a^2 - 25 = (3a)^2 - 5^2 = (3a + 5)(3a - 5)$

$$\begin{aligned}
 \text{c) } 6x^4 - 6y^4 &= 6(x^4 - y^4) \\
 &= 6[(x^2)^2 - (y^2)^2] \\
 &= 6(x^2 + y^2)(x^2 - y^2) \\
 &= 6(x^2 + y^2)(x + y)(x - y)
 \end{aligned}$$

$x^2 - y^2$ can be factored further.

Because none of these factors can be factored further, we have *factored completely*.

 **Now Try Exercise 49.**

The rules for squaring binomials can be reversed to factor trinomials that are squares of binomials:

$$\begin{aligned}
 A^2 + 2AB + B^2 &= (A + B)^2; \\
 A^2 - 2AB + B^2 &= (A - B)^2.
 \end{aligned}$$

EXAMPLE 9 Factor each of the following.

a) $x^2 + 8x + 16$

b) $25y^2 - 30y + 9$

Solution

$$A^2 + 2 \cdot A \cdot B + B^2 = (A + B)^2$$

a) $x^2 + 8x + 16 = x^2 + 2 \cdot x \cdot 4 + 4^2 = (x + 4)^2$

$$A^2 - 2 \cdot A \cdot B + B^2 = (A - B)^2$$

b) $25y^2 - 30y + 9 = (5y)^2 - 2 \cdot 5y \cdot 3 + 3^2 = (5y - 3)^2$

 **Now Try Exercise 57.**

We can use the following rules to factor a **sum** or a **difference of cubes**:

$$\begin{aligned}
 A^3 + B^3 &= (A + B)(A^2 - AB + B^2); \\
 A^3 - B^3 &= (A - B)(A^2 + AB + B^2).
 \end{aligned}$$

These rules can be verified by multiplying.

EXAMPLE 10 Factor each of the following.

a) $x^3 + 27$

b) $16y^3 - 250$

Solution

a) $x^3 + 27 = x^3 + 3^3$
 $= (x + 3)(x^2 - 3x + 9)$

$$\begin{aligned}
 \text{b) } 16y^3 - 250 &= 2(8y^3 - 125) \\
 &= 2[(2y)^3 - 5^3] \\
 &= 2(2y - 5)(4y^2 + 10y + 25)
 \end{aligned}$$

 Now Try Exercises 67 and 69.

Not all polynomials can be factored into polynomials with integer coefficients. An example is $x^2 - x + 7$. There are no real factors of 7 whose sum is -1 . In such a case, we say that the polynomial is “not factorable,” or **prime**.

CONNECTING THE CONCEPTS

A Strategy for Factoring

- A. Always factor out the largest common factor first.
- B. Look at the number of terms.

Two terms: Try factoring as a difference of squares first. Next, try factoring as a sum or a difference of cubes. There is no rule for factoring a *sum* of squares.

Three terms: Try factoring as the square of a binomial. Next, try using the FOIL method or the grouping method for factoring a trinomial.

Four or more terms: Try factoring by grouping and factoring out a common binomial factor.

- C. Always *factor completely*. If a factor with more than one term can itself be factored further, do so.



R.4

Exercise Set

Factor out the largest common factor.

- | | |
|------------------------------|----------------------|
| 1. $3x + 18$ | 2. $5y - 20$ |
| 3. $2z^3 - 8z^2$ | 4. $12m^2 + 3m^6$ |
| 5. $4a^2 - 12a + 16$ | 6. $6n^2 + 24n - 18$ |
| 7. $a(b - 2) + c(b - 2)$ | |
| 8. $a(x^2 - 3) - 2(x^2 - 3)$ | |

Factor by grouping.

- | | |
|---------------------------|----------------------------|
| 9. $3x^3 - x^2 + 18x - 6$ | 10. $x^3 + 3x^2 + 6x + 18$ |
| 11. $y^3 - y^2 + 2y - 2$ | 12. $y^3 - y^2 + 3y - 3$ |

13. $24x^3 - 36x^2 + 72x - 108$

14. $5a^3 - 10a^2 + 25a - 50$

15. $x^3 - x^2 - 5x + 5$

16. $t^3 + 6t^2 - 2t - 12$

17. $a^3 - 3a^2 - 2a + 6$

18. $x^3 - x^2 - 6x + 6$

Factor the trinomial.

19. $w^2 - 7w + 10$

20. $p^2 + 6p + 8$

21. $x^2 + 6x + 5$

22. $x^2 - 8x + 12$

- | | | | |
|-----------------------------|-------------------------------|----------------------------|---------------------------|
| 23. $t^2 + 8t + 15$ | 24. $y^2 + 12y + 27$ | 79. $x^3 - 4x^2 + 5x - 20$ | 80. $z^3 + 3z^2 - 3z - 9$ |
| 25. $x^2 - 6xy - 27y^2$ | 26. $t^2 - 2t - 15$ | 81. $8x^2 - 32$ | 82. $6y^2 - 6$ |
| 27. $2n^2 - 20n - 48$ | 28. $2a^2 - 2ab - 24b^2$ | 83. $4y^2 - 5$ | 84. $16x^2 - 7$ |
| 29. $y^2 - 4y - 21$ | 30. $m^2 - m - 90$ | 85. $m^2 - 9n^2$ | 86. $25t^2 - 16$ |
| 31. $y^4 - 9y^3 + 14y^2$ | 32. $3z^3 - 21z^2 + 18z$ | 87. $x^2 + 9x + 20$ | 88. $y^2 + y - 6$ |
| 33. $2x^3 - 2x^2y - 24xy^2$ | 34. $a^3b - 9a^2b^2 + 20ab^3$ | 89. $y^2 - 6y + 5$ | 90. $x^2 - 4x - 21$ |
| 35. $2n^2 + 9n - 56$ | 36. $3y^2 + 7y - 20$ | 91. $2a^2 + 9a + 4$ | 92. $3b^2 - b - 2$ |
| 37. $12x^2 + 11x + 2$ | 38. $6x^2 - 7x - 20$ | 93. $6x^2 + 7x - 3$ | 94. $8x^2 + 2x - 15$ |
| 39. $4x^2 + 15x + 9$ | 40. $2y^2 + 7y + 6$ | 95. $y^2 - 18y + 81$ | 96. $n^2 + 2n + 1$ |
| 41. $2y^2 + y - 6$ | 42. $20p^2 - 23p + 6$ | 97. $9z^2 - 24z + 16$ | 98. $4z^2 + 20z + 25$ |
| 43. $6a^2 - 29ab + 28b^2$ | 44. $10m^2 + 7mn - 12n^2$ | 99. $x^2y^2 - 14xy + 49$ | 100. $x^2y^2 - 16xy + 64$ |
| 45. $12a^2 - 4a - 16$ | 46. $12a^2 - 14a - 20$ | 101. $4ax^2 + 20ax - 56a$ | 102. $21x^2y + 2xy - 8y$ |

Factor the difference of squares.

- | | | | |
|---------------------|-----------------------|-----------------------------|-----------------------------|
| 47. $z^2 - 81$ | 48. $m^2 - 4$ | 103. $3z^3 - 24$ | 104. $4t^3 + 108$ |
| 49. $16x^2 - 9$ | 50. $4z^2 - 81$ | 105. $16a^7b + 54ab^7$ | 106. $24a^2x^4 - 375a^8x$ |
| 51. $6x^2 - 6y^2$ | 52. $8a^2 - 8b^2$ | 107. $y^3 - 3y^2 - 4y + 12$ | 108. $p^3 - 2p^2 - 9p + 18$ |
| 53. $4xy^4 - 4xz^2$ | 54. $5x^2y - 5yz^4$ | 109. $x^3 - x^2 + x - 1$ | 110. $x^3 - x^2 - x + 1$ |
| 55. $7pq^4 - 7py^4$ | 56. $25ab^4 - 25az^4$ | 111. $5m^4 - 20$ | 112. $2x^2 - 288$ |

Factor the square of a binomial.

- | | | | |
|--------------------------|--------------------------|------------------------------|-------------------------------|
| 57. $x^2 + 12x + 36$ | 58. $y^2 - 6y + 9$ | 113. $2x^3 + 6x^2 - 8x - 24$ | 114. $3x^3 + 6x^2 - 27x - 54$ |
| 59. $9z^2 - 12z + 4$ | 60. $4z^2 + 12z + 9$ | 115. $4c^2 - 4cd + d^2$ | 116. $9a^2 - 6ab + b^2$ |
| 61. $1 - 8x + 16x^2$ | 62. $1 + 10x + 25x^2$ | 117. $m^6 + 8m^3 - 20$ | 118. $x^4 - 37x^2 + 36$ |
| 63. $a^3 + 24a^2 + 144a$ | 64. $y^3 - 18y^2 + 81y$ | 119. $p - 64p^4$ | 120. $125a - 8a^4$ |
| 65. $4p^2 - 8pq + 4q^2$ | 66. $5a^2 - 10ab + 5b^2$ | | |

Factor the sum or difference of cubes.

- | | | | |
|--------------------|-------------------|--|--|
| 67. $x^3 + 64$ | 68. $y^3 - 8$ | 121. $y^4 - 84 + 5y^2$ | 122. $11x^2 + x^4 - 80$ |
| 69. $m^3 - 216$ | 70. $n^3 + 1$ | 123. $y^2 - \frac{8}{49} + \frac{2}{7}y$ | 124. $t^2 - \frac{27}{100} + \frac{3}{5}t$ |
| 71. $8t^3 + 8$ | 72. $2y^3 - 128$ | 125. $x^2 + 3x + \frac{9}{4}$ | 126. $x^2 - 5x + \frac{25}{4}$ |
| 73. $3a^5 - 24a^2$ | 74. $250z^4 - 2z$ | 127. $x^2 - x + \frac{1}{4}$ | 128. $x^2 - \frac{2}{3}x + \frac{1}{9}$ |
| 75. $t^6 + 1$ | 76. $27x^6 - 8$ | 129. $(x + h)^3 - x^3$ | 130. $(x + 0.01)^2 - x^2$ |

Factor completely.

- | | | | |
|-----------------------|----------------------|----------------------------------|-------------------------------------|
| 77. $18a^2b - 15ab^2$ | 78. $4x^2y + 12xy^2$ | 131. $(y - 4)^2 + 5(y - 4) - 24$ | 132. $6(2p + q)^2 - 5(2p + q) - 25$ |
|-----------------------|----------------------|----------------------------------|-------------------------------------|

Synthesis

Factor.

Factor. Assume that variables in exponents represent natural numbers.

133. $x^{2n} + 5x^n - 24$

134. $4x^{2n} - 4x^n - 3$

135. $x^2 + ax + bx + ab$

136. $bdy^2 + ady + bcy + ac$

137. $25y^{2m} - (x^{2n} - 2x^n + 1)$

138. $x^{6a} - t^{3b}$

139. $(y - 1)^4 - (y - 1)^2$

140. $x^6 - 2x^5 + x^4 - x^2 + 2x - 1$

The Basics of Equation Solving

R.5

- ▶ Solve linear equations.
- ▶ Solve quadratic equations.
- ▶ Solve a formula for a given letter.

An **equation** is a statement that two expressions are equal. To **solve** an equation in one variable is to find all the values of the variable that make the equation true. Each of these numbers is a **solution** of the equation. The set of all solutions of an equation is its **solution set**. Equations that have the same solution set are called **equivalent equations**.

▶ Linear Equations and Quadratic Equations

A **linear equation in one variable** is an equation that is equivalent to one of the form $ax + b = 0$, where a and b are real numbers and $a \neq 0$.

A **quadratic equation** is an equation that is equivalent to one of the form $ax^2 + bx + c = 0$, where a , b , and c are real numbers and $a \neq 0$.

The following principles allow us to solve many linear equations and quadratic equations.

Equation-Solving Principles

For any real numbers a , b , and c ,

The Addition Principle: If $a = b$ is true, then $a + c = b + c$ is true.

The Multiplication Principle: If $a = b$ is true, then $ac = bc$ is true.

The Principle of Zero Products: If $ab = 0$ is true, then $a = 0$ or $b = 0$, and if $a = 0$ or $b = 0$, then $ab = 0$.

The Principle of Square Roots: If $x^2 = k$, then $x = \sqrt{k}$ or $x = -\sqrt{k}$.

First, we consider a linear equation. We will use the addition and multiplication principles to solve it.

EXAMPLE 1 Solve: $2x + 3 = 1 - 6(x - 1)$.

Solution We begin by using the distributive property to remove the parentheses.

$$\begin{array}{ll}
 2x + 3 = 1 - 6(x - 1) & \\
 2x + 3 = 1 - 6x + 6 & \text{Using the distributive property} \\
 2x + 3 = 7 - 6x & \text{Combining like terms} \\
 8x + 3 = 7 & \text{Using the addition principle to add } 6x \text{ on both sides} \\
 8x = 4 & \text{Using the addition principle to add } -3, \text{ or subtract } 3, \text{ on both sides} \\
 x = \frac{4}{8} & \text{Using the multiplication principle to multiply by } \frac{1}{8}, \text{ or divide by } 8, \text{ on both sides} \\
 x = \frac{1}{2} & \text{Simplifying}
 \end{array}$$

We check the result in the original equation.

Check:

$$\begin{array}{r|l}
 2x + 3 = 1 - 6(x - 1) & \\
 2 \cdot \frac{1}{2} + 3 \quad ? \quad 1 - 6\left(\frac{1}{2} - 1\right) & \text{Substituting } \frac{1}{2} \text{ for } x \\
 1 + 3 \quad \left| \quad 1 - 6\left(-\frac{1}{2}\right) & \\
 4 \quad \left| \quad 1 + 3 & \\
 4 \quad \left| \quad 4 & \text{TRUE}
 \end{array}$$

The solution is $\frac{1}{2}$.

 **Now Try Exercise 13.**

Next, we consider a quadratic equation that can be solved using the principle of zero products.

EXAMPLE 2 Solve: $x^2 - 3x = 4$.

Solution First, we write the equation with 0 on one side.

$$\begin{array}{ll}
 x^2 - 3x = 4 & \\
 x^2 - 3x - 4 = 0 & \text{Subtracting } 4 \text{ on both sides} \\
 (x + 1)(x - 4) = 0 & \text{Factoring} \\
 x + 1 = 0 \quad \text{or} \quad x - 4 = 0 & \text{Using the principle of} \\
 & \text{zero products} \\
 x = -1 \quad \text{or} \quad x = 4 &
 \end{array}$$

*Check:*For -1 :

$$\begin{array}{r|l} x^2 - 3x = 4 & \\ \hline (-1)^2 - 3(-1) & ? 4 \\ 1 + 3 & \\ 4 & 4 \quad \text{TRUE} \end{array}$$

For 4 :

$$\begin{array}{r|l} x^2 - 3x = 4 & \\ \hline 4^2 - 3 \cdot 4 & ? 4 \\ 16 - 12 & \\ 4 & 4 \quad \text{TRUE} \end{array}$$

The solutions are -1 and 4 .
 **Now Try Exercise 35.**

The principle of square roots can be used to solve some quadratic equations, as we see in the next example.

EXAMPLE 3 Solve: $3x^2 - 6 = 0$.**Solution** We use the principle of square roots.

$$3x^2 - 6 = 0$$

$$3x^2 = 6 \quad \text{Adding 6 on both sides}$$

$$x^2 = 2 \quad \text{Dividing by 3 on both sides to isolate } x^2$$

$$x = \sqrt{2} \quad \text{or} \quad x = -\sqrt{2} \quad \text{Using the principle of square roots}$$

Both numbers check. The solutions are $\sqrt{2}$ and $-\sqrt{2}$, or $\pm\sqrt{2}$ (read “plus or minus $\sqrt{2}$ ”).

 **Now Try Exercise 53.**

► Formulas

A **formula** is an equation that can be used to model a situation. For example, the formula $P = 2l + 2w$ gives the perimeter of a rectangle with length l and width w .

The equation-solving principles presented earlier can be used to solve a formula for a given letter.

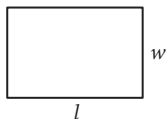
**EXAMPLE 4** Solve $P = 2l + 2w$ for l .**Solution** We have

$$P = 2l + 2w \quad \text{We want to isolate } l.$$

$$P - 2w = 2l \quad \text{Subtracting } 2w \text{ on both sides}$$

$$\frac{P - 2w}{2} = l \quad \text{Dividing by 2 on both sides}$$

 **Now Try Exercise 63.**

The formula $l = \frac{P - 2w}{2}$ can be used to determine a rectangle's length if we are given the perimeter and the width of the rectangle.

EXAMPLE 5 The formula $A = P + Prt$ gives the amount A to which a principal of P dollars will grow when invested at simple interest rate r for t years. Solve the formula for P .

Solution We have

$$A = P + Prt$$

We want to isolate P .

$$A = P(1 + rt)$$

Factoring

$$\frac{A}{1 + rt} = \frac{P(1 + rt)}{1 + rt}$$

Dividing by $1 + rt$ on both sides

$$\frac{A}{1 + rt} = P.$$

 Now Try Exercise 77.

The formula $P = \frac{A}{1 + rt}$ can be used to determine how much should be invested at simple interest rate r in order to have A dollars t years later.

EXAMPLE 6 Solve $A = \frac{1}{2}h(b_1 + b_2)$ for b_1 .

Solution We have

$$A = \frac{1}{2}h(b_1 + b_2)$$

Formula for the area of a trapezoid

$$2A = h(b_1 + b_2)$$

Multiplying by 2

$$2A = hb_1 + hb_2$$

Removing parentheses

$$2A - hb_2 = hb_1$$

Subtracting hb_2

$$\frac{2A - hb_2}{h} = b_1.$$

Dividing by h

 Now Try Exercise 65.

R.5

Exercise Set

Solve.

1. $x - 5 = 7$

2. $y + 3 = 4$

15. $7y - 1 = 23 - 5y$

16. $3x - 15 = 15 - 3x$

3. $3x + 4 = -8$

4. $5x - 7 = 23$

17. $3x - 4 = 5 + 12x$

18. $9t - 4 = 14 + 15t$

5. $5y - 12 = 3$

6. $6x + 23 = 5$

19. $5 - 4a = a - 13$

20. $6 - 7x = x - 14$

7. $6x - 15 = 45$

8. $4x - 7 = 81$

21. $3m - 7 = -13 + m$

22. $5x - 8 = 2x - 8$

9. $5x - 10 = 45$

10. $6x - 7 = 11$

23. $11 - 3x = 5x + 3$

24. $20 - 4y = 10 - 6y$

11. $9t + 4 = -5$

12. $5x + 7 = -13$

25. $2(x + 7) = 5x + 14$

26. $3(y + 4) = 8y$

13. $8x + 48 = 3x - 12$

14. $15x + 40 = 8x - 9$

27. $24 = 5(2t + 5)$

28. $9 = 4(3y - 2)$

29. $5y - (2y - 10) = 25$

30. $8x - (3x - 5) = 40$

31. $7(3x + 6) = 11 - (x + 2)$
 32. $9(2x + 8) = 20 - (x + 5)$
 33. $4(3y - 1) - 6 = 5(y + 2)$
 34. $3(2n - 5) - 7 = 4(n - 9)$
 35. $x^2 + 3x - 28 = 0$
 36. $y^2 - 4y - 45 = 0$
 37. $x^2 + 5x = 0$
 38. $t^2 + 6t = 0$
 39. $y^2 + 6y + 9 = 0$
 40. $n^2 + 4n + 4 = 0$
 41. $x^2 + 100 = 20x$
 42. $y^2 + 25 = 10y$
 43. $x^2 - 4x - 32 = 0$
 44. $t^2 + 12t + 27 = 0$
 45. $3y^2 + 8y + 4 = 0$
 46. $9y^2 + 15y + 4 = 0$
 47. $12z^2 + z = 6$
 48. $6x^2 - 7x = 10$
 49. $12a^2 - 28 = 5a$
 50. $21n^2 - 10 = n$
 51. $14 = x(x - 5)$
 52. $24 = x(x - 2)$
 53. $x^2 - 36 = 0$
 54. $y^2 - 81 = 0$
 55. $z^2 = 144$
 56. $t^2 = 25$
 57. $2x^2 - 20 = 0$
 58. $3y^2 - 15 = 0$
 59. $6z^2 - 18 = 0$
 60. $5x^2 - 75 = 0$

Solve.

61. $A = \frac{1}{2}bh$, for b
 (Area of a triangle)

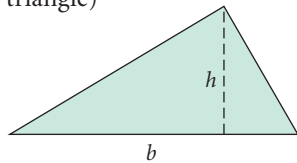

62. $A = \pi r^2$, for π
 (Area of a circle)

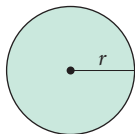

63. $P = 2l + 2w$, for w
 (Perimeter of a rectangle)
 64. $A = P + Prt$, for r
 (Simple interest)

65. $A = \frac{1}{2}h(b_1 + b_2)$, for h
 (Area of a trapezoid)
 66. $A = \frac{1}{2}h(b_1 + b_2)$, for b_2
 67. $V = \frac{4}{3}\pi r^3$, for π
 (Volume of a sphere)
 68. $V = \frac{4}{3}\pi r^3$, for r^3
 69. $F = \frac{9}{5}C + 32$, for C
 (Temperature conversion)
 70. $Ax + By = C$, for y
 (Standard linear equation)
 71. $Ax + By = C$, for A
 72. $2w + 2h + l = p$, for w
 73. $2w + 2h + l = p$, for h
 74. $3x + 4y = 12$, for y
 75. $2x - 3y = 6$, for y
 76. $T = \frac{3}{10}(I - 12,000)$, for I
 77. $a = b + bcd$, for b
 78. $q = p - np$, for p
 79. $z = xy - xy^2$, for x
 80. $st = t - 4$, for t

Synthesis

Solve.

81. $3[5 - 3(4 - t)] - 2 = 5[3(5t - 4) + 8] - 26$
 82. $6[4(8 - y) - 5(9 + 3y)] - 21 = -7[3(7 + 4y) - 4]$
 83. $x - \{3x - [2x - (5x - (7x - 1))]\} = x + 7$
 84. $23 - 2[4 + 3(x - 1)] + 5[x - 2(x + 3)] = 7\{x - 2[5 - (2x + 3)]\}$
 85. $(5x^2 + 6x)(12x^2 - 5x - 2) = 0$
 86. $(3x^2 + 7x - 20)(x^2 - 4x) = 0$
 87. $3x^3 + 6x^2 - 27x - 54 = 0$
 88. $2x^3 + 6x^2 = 8x + 24$

Rational Expressions

R.6

- ▶ Determine the domain of a rational expression.
- ▶ Simplify rational expressions.
- ▶ Multiply, divide, add, and subtract rational expressions.
- ▶ Simplify complex rational expressions.

A **rational expression** is the quotient of two polynomials. For example,

$$\frac{3}{5}, \quad \frac{2}{x-3}, \quad \text{and} \quad \frac{x^2-4}{x^2-4x-5}$$

are rational expressions.

▶ The Domain of a Rational Expression

The **domain** of an algebraic expression is the set of all real numbers for which the expression is defined. Since division by 0 is not defined, any number that makes the denominator 0 is not in the domain of a rational expression.

EXAMPLE 1 Find the domain of each of the following.

a) $\frac{2}{x-3}$

b) $\frac{x^2-4}{x^2-4x-5}$

Solution

- a) We solve the equation $x - 3 = 0$ to determine the numbers that are *not* in the domain:

$$x - 3 = 0$$

$$x = 3. \quad \text{Adding 3 on both sides}$$

Since the denominator is 0 when $x = 3$, the domain of $2/(x - 3)$ is the set of all real numbers except 3.

- b) We solve the equation $x^2 - 4x - 5 = 0$ to find the numbers that are not in the domain:

$$x^2 - 4x - 5 = 0$$

$$(x + 1)(x - 5) = 0$$

$$x + 1 = 0 \quad \text{or} \quad x - 5 = 0$$

$$x = -1 \quad \text{or} \quad x = 5.$$

Factoring

Using the principle of zero products

Since the denominator is 0 when $x = -1$ or $x = 5$, the domain is the set of all real numbers except -1 and 5 .

➡ Now Try Exercise 3.

We can describe the domains found in Example 1 using *set-builder notation*. For example, we write “The set of all real numbers x such that x is not equal to 3” as

$$\{x \mid x \text{ is a real number and } x \neq 3\}.$$

Similarly, we write “The set of all real numbers x such that x is not equal to -1 and x is not equal to 5 ” as

$$\{x \mid x \text{ is a real number and } x \neq -1 \text{ and } x \neq 5\}.$$

► Simplifying, Multiplying, and Dividing Rational Expressions

To simplify rational expressions, we use the fact that

$$\frac{a \cdot c}{b \cdot c} = \frac{a}{b} \cdot \frac{c}{c} = \frac{a}{b} \cdot 1 = \frac{a}{b}.$$

EXAMPLE 2 Simplify: $\frac{9x^2 + 6x - 3}{12x^2 - 12}$.

Solution

$$\begin{aligned} \frac{9x^2 + 6x - 3}{12x^2 - 12} &= \frac{3(3x^2 + 2x - 1)}{12(x^2 - 1)} \\ &= \frac{3(x + 1)(3x - 1)}{3 \cdot 4(x + 1)(x - 1)} \\ &= \frac{3(x + 1)}{3(x + 1)} \cdot \frac{3x - 1}{4(x - 1)} \\ &= 1 \cdot \frac{3x - 1}{4(x - 1)} \\ &= \frac{3x - 1}{4(x - 1)} \end{aligned}$$

Factoring the numerator and the denominator

Factoring the rational expression

$$\frac{3(x + 1)}{3(x + 1)} = 1$$

Removing a factor of 1

➔ Now Try Exercise 9.

Canceling is a shortcut that is often used to remove a factor of 1.

EXAMPLE 3 Simplify each of the following.

$$\text{a) } \frac{4x^3 + 16x^2}{2x^3 + 6x^2 - 8x} \qquad \text{b) } \frac{2 - x}{x^2 + x - 6}$$

Solution

$$\begin{aligned} \text{a) } \frac{4x^3 + 16x^2}{2x^3 + 6x^2 - 8x} &= \frac{2 \cdot 2 \cdot x \cdot x(x + 4)}{2 \cdot x(x + 4)(x - 1)} \\ &= \frac{2 \cdot 2 \cdot \cancel{x} \cdot \cancel{x}(x + 4)}{2 \cdot \cancel{x}(x + 4)(x - 1)} \\ &= \frac{2x}{x - 1} \end{aligned}$$

Factoring the numerator and the denominator

Removing a factor of 1:

$$\frac{2x(x + 4)}{2x(x + 4)} = 1$$

$$\begin{aligned}
 \text{b) } \frac{2-x}{x^2+x-6} &= \frac{2-x}{(x+3)(x-2)} \\
 &= \frac{-1(x-2)}{(x+3)(x-2)} \\
 &= \frac{-1(\cancel{x-2})}{(x+3)(\cancel{x-2})} \\
 &= \frac{-1}{x+3}, \text{ or } -\frac{1}{x+3}
 \end{aligned}$$

Factoring the denominator

$$2 - x = -1(x - 2)$$

$$\text{Removing a factor of 1: } \frac{x-2}{x-2} = 1$$

 Now Try Exercises 11 and 15.

In Example 3(b), we saw that

$$\frac{2-x}{x^2+x-6} \quad \text{and} \quad -\frac{1}{x+3}$$

are **equivalent expressions**. This means that they have the same value for all numbers that are in *both* domains. Note that -3 is not in the domain of *either* expression, whereas 2 is in the domain of $-1/(x+3)$ but not in the domain of $(2-x)/(x^2+x-6)$ and thus is not in the domain of *both* expressions.

To multiply rational expressions, we multiply numerators and multiply denominators and, if possible, simplify the result. To divide rational expressions, we multiply the dividend by the reciprocal of the divisor and, if possible, simplify the result. That is,

$$\frac{a}{b} \cdot \frac{c}{d} = \frac{ac}{bd} \quad \text{and} \quad \frac{a}{b} \div \frac{c}{d} = \frac{a}{b} \cdot \frac{d}{c} = \frac{ad}{bc}.$$

EXAMPLE 4 Multiply or divide and simplify each of the following.

$$\begin{array}{ll}
 \text{a) } \frac{a^2-4}{16a} \cdot \frac{20a^2}{a+2} & \text{b) } \frac{x+4}{2x^2-6x} \cdot \frac{x^4-9x^2}{x^2+2x-8} \\
 \text{c) } \frac{x-2}{12} \div \frac{x^2-4x+4}{3x^3+15x^2} & \text{d) } \frac{y^3-1}{y^2-1} \div \frac{y^2+y+1}{y^2+2y+1}
 \end{array}$$

Solution

$$\begin{aligned}
 \text{a) } \frac{a^2-4}{16a} \cdot \frac{20a^2}{a+2} &= \frac{(a^2-4)(20a^2)}{16a(a+2)} && \text{Multiplying the numerators} \\
 &= \frac{\cancel{(a+2)}(a-2) \cdot 4 \cdot 5 \cdot a \cdot a}{4 \cdot 4 \cdot a \cdot \cancel{(a+2)}} && \text{Factoring and removing a factor of 1} \\
 &= \frac{5a(a-2)}{4}
 \end{aligned}$$

$$\begin{aligned}
 \text{b) } & \frac{x+4}{2x^2-6x} \cdot \frac{x^4-9x^2}{x^2+2x-8} \\
 &= \frac{(x+4)(x^4-9x^2)}{(2x^2-6x)(x^2+2x-8)} \\
 &= \frac{(x+4)(x^2)(x^2-9)}{2x(x-3)(x+4)(x-2)} \\
 &= \frac{\cancel{(x+4)} \cdot \cancel{x} \cdot x \cdot (x+3)\cancel{(x-3)}}{2 \cdot \cancel{x} \cdot \cancel{(x-3)} \cdot \cancel{(x+4)} \cdot (x-2)} \\
 &= \frac{x(x+3)}{2(x-2)}
 \end{aligned}$$

Multiplying the numerators
and the denominators

Factoring

Factoring further and
removing a factor of 1

$$\begin{aligned}
 \text{c) } & \frac{x-2}{12} \div \frac{x^2-4x+4}{3x^3+15x^2} \\
 &= \frac{x-2}{12} \cdot \frac{3x^3+15x^2}{x^2-4x+4} \\
 &= \frac{(x-2)(3x^3+15x^2)}{12(x^2-4x+4)} \\
 &= \frac{\cancel{(x-2)}(\cancel{3})(x^2)(x+5)}{\cancel{3} \cdot 4 \cdot \cancel{(x-2)}(x-2)} \\
 &= \frac{x^2(x+5)}{4(x-2)}
 \end{aligned}$$

Multiplying by the reciprocal
of the divisor

Factoring and removing a factor of 1

$$\begin{aligned}
 \text{d) } & \frac{y^3-1}{y^2-1} \div \frac{y^2+y+1}{y^2+2y+1} \\
 &= \frac{y^3-1}{y^2-1} \cdot \frac{y^2+2y+1}{y^2+y+1} \\
 &= \frac{(y^3-1)(y^2+2y+1)}{(y^2-1)(y^2+y+1)} \\
 &= \frac{\cancel{(y-1)}(\cancel{y^2+y+1})(y+1)(y+1)}{\cancel{(y-1)}(\cancel{y^2+y+1})(y^2+y+1)} \\
 &= y+1
 \end{aligned}$$

Multiplying by the
reciprocal of the
divisor

Factoring and
removing a factor
of 1

➔ Now Try Exercises 19 and 25.

► Adding and Subtracting Rational Expressions

When rational expressions have the same denominator, we can add or subtract by adding or subtracting the numerators and retaining the common denominator. If the denominators differ, we must find equivalent rational expressions that have a common denominator. In general, it is most efficient to find the **least common denominator (LCD)** of the expressions.

To find the least common denominator of rational expressions, factor each denominator and form the product that uses each factor the greatest number of times it occurs in any factorization.

EXAMPLE 5 Add or subtract and simplify each of the following.

$$\begin{array}{ll} \text{a) } \frac{x^2 - 4x + 4}{2x^2 - 3x + 1} + \frac{x + 4}{2x - 2} & \text{b) } \frac{x - 2}{x^2 - 25} - \frac{x + 5}{x^2 - 5x} \\ \text{c) } \frac{x}{x^2 + 11x + 30} - \frac{5}{x^2 + 9x + 20} \end{array}$$

Solution

$$\begin{aligned} \text{a) } \frac{x^2 - 4x + 4}{2x^2 - 3x + 1} + \frac{x + 4}{2x - 2} &= \frac{x^2 - 4x + 4}{(2x - 1)(x - 1)} + \frac{x + 4}{2(x - 1)} && \text{Factoring the denominators} \\ &\text{The LCD is } (2x - 1)(x - 1)(2), \text{ or } 2(2x - 1)(x - 1). \\ &= \frac{x^2 - 4x + 4}{(2x - 1)(x - 1)} \cdot \frac{2}{2} + \frac{x + 4}{2(x - 1)} \cdot \frac{2x - 1}{2x - 1} && \text{Multiplying each term by 1 to get the LCD} \\ &= \frac{2x^2 - 8x + 8}{(2x - 1)(x - 1)(2)} + \frac{2x^2 + 7x - 4}{2(x - 1)(2x - 1)} \\ &= \frac{4x^2 - x + 4}{2(2x - 1)(x - 1)} && \text{Adding the numerators; we cannot simplify.} \end{aligned}$$

$$\begin{aligned} \text{b) } \frac{x - 2}{x^2 - 25} - \frac{x + 5}{x^2 - 5x} &= \frac{x - 2}{(x + 5)(x - 5)} - \frac{x + 5}{x(x - 5)} && \text{Factoring the denominators} \\ &\text{The LCD is } (x + 5)(x - 5)(x), \text{ or } x(x + 5)(x - 5). \\ &= \frac{x - 2}{(x + 5)(x - 5)} \cdot \frac{x}{x} - \frac{x + 5}{x(x - 5)} \cdot \frac{x + 5}{x + 5} && \text{Multiplying each term by 1 to get the LCD} \\ &= \frac{x^2 - 2x}{x(x + 5)(x - 5)} - \frac{x^2 + 10x + 25}{x(x + 5)(x - 5)} \\ &= \frac{x^2 - 2x - (x^2 + 10x + 25)}{x(x + 5)(x - 5)} && \text{Subtracting numerators and keeping the common denominator} \\ &= \frac{x^2 - 2x - x^2 - 10x - 25}{x(x + 5)(x - 5)} && \text{Removing parentheses} \\ &= \frac{-12x - 25}{x(x + 5)(x - 5)} && \text{Adding the numerators; we cannot simplify.} \end{aligned}$$

$$\begin{aligned}
 \text{c) } & \frac{x}{x^2 + 11x + 30} - \frac{5}{x^2 + 9x + 20} \\
 &= \frac{x}{(x+5)(x+6)} - \frac{5}{(x+5)(x+4)} && \text{Factoring the denominators} \\
 & \text{The LCD is } (x+5)(x+6)(x+4). \\
 &= \frac{x}{(x+5)(x+6)} \cdot \frac{x+4}{x+4} - \frac{5}{(x+5)(x+4)} \cdot \frac{x+6}{x+6} \\
 & && \text{Multiplying each term by 1 to get the LCD} \\
 &= \frac{x^2 + 4x}{(x+5)(x+6)(x+4)} - \frac{5x + 30}{(x+5)(x+4)(x+6)} \\
 &= \frac{x^2 + 4x - 5x - 30}{(x+5)(x+6)(x+4)} && \text{Be sure to change the sign of every} \\
 & && \text{term in the numerator of the} \\
 & && \text{expression being subtracted:} \\
 & && -(5x + 30) = -5x - 30. \\
 &= \frac{x^2 - x - 30}{(x+5)(x+6)(x+4)} \\
 &= \frac{\cancel{(x+5)}(x-6)}{\cancel{(x+5)}(x+6)(x+4)} && \text{Factoring and removing a factor} \\
 & && \text{of 1: } \frac{x+5}{x+5} = 1 \\
 &= \frac{x-6}{(x+6)(x+4)}
 \end{aligned}$$

 Now Try Exercises 37 and 39.

► Complex Rational Expressions

A **complex rational expression** has rational expressions in its numerator or its denominator or both.

To simplify a complex rational expression:

Method 1. Find the LCD of all the denominators within the complex rational expression. Then multiply by 1 using the LCD as the numerator and the denominator of the expression for 1.

Method 2. First add or subtract, if necessary, to get a single rational expression in the numerator and in the denominator. Then divide by multiplying by the reciprocal of the denominator.

EXAMPLE 6 Simplify: $\frac{\frac{1}{a} + \frac{1}{b}}{\frac{1}{a^3} + \frac{1}{b^3}}$.

Solution

Method 1. The LCD of the four rational expressions in the numerator and the denominator is a^3b^3 .

$$\begin{aligned} \frac{\frac{1}{a} + \frac{1}{b}}{\frac{1}{a^3} + \frac{1}{b^3}} &= \frac{\frac{1}{a} + \frac{1}{b}}{\frac{1}{a^3} + \frac{1}{b^3}} \cdot \frac{a^3b^3}{a^3b^3} && \text{Multiplying by 1 using } \frac{a^3b^3}{a^3b^3} \\ &= \frac{\left(\frac{1}{a} + \frac{1}{b}\right)(a^3b^3)}{\left(\frac{1}{a^3} + \frac{1}{b^3}\right)(a^3b^3)} \\ &= \frac{a^2b^3 + a^3b^2}{b^3 + a^3} \\ &= \frac{a^2b^2(\cancel{b+a})}{(\cancel{b+a})(b^2 - ba + a^2)} && \text{Factoring and removing} \\ & && \text{a factor of 1: } \frac{b+a}{b+a} = 1 \\ &= \frac{a^2b^2}{b^2 - ba + a^2} \end{aligned}$$

Method 2. We add in the numerator and in the denominator.

$$\begin{aligned} \frac{\frac{1}{a} + \frac{1}{b}}{\frac{1}{a^3} + \frac{1}{b^3}} &= \frac{\frac{1}{a} \cdot \frac{b}{b} + \frac{1}{b} \cdot \frac{a}{a}}{\frac{1}{a^3} \cdot \frac{b^3}{b^3} + \frac{1}{b^3} \cdot \frac{a^3}{a^3}} \leftarrow \text{The LCD is } ab. \\ &= \frac{\frac{b}{ab} + \frac{a}{ab}}{\frac{b^3}{a^3b^3} + \frac{a^3}{a^3b^3}} \leftarrow \text{The LCD is } a^3b^3. \\ &= \frac{\frac{b+a}{ab}}{\frac{b^3+a^3}{a^3b^3}} \\ &= \frac{b+a}{ab} \cdot \frac{a^3b^3}{b^3+a^3} && \text{We have a single rational expression} \\ & && \text{in both the numerator and the} \\ & && \text{denominator.} \\ &= \frac{(b+a)(a)(b)(a^2b^2)}{(a)(b)(\cancel{b+a})(b^2 - ba + a^2)} && \text{Multiplying by the reciprocal of} \\ & && \text{the denominator} \\ &= \frac{a^2b^2}{b^2 - ba + a^2} \end{aligned}$$

 Now Try Exercise 57.

R.6

Exercise Set

Find the domain of the rational expression.

1. $-\frac{5}{3}$

2. $\frac{4}{7-x}$

3. $\frac{3x-3}{x(x-1)}$

4. $\frac{15x-10}{2x(3x-2)}$

5. $\frac{x+5}{x^2+4x-5}$

6. $\frac{(x^2-4)(x+1)}{(x+2)(x^2-1)}$

7. $\frac{7x^2-28x+28}{(x^2-4)(x^2+3x-10)}$

8. $\frac{7x^2+11x-6}{x(x^2-x-6)}$

Simplify.

9. $\frac{x^2-4}{x^2-4x+4}$

10. $\frac{x^2+2x-3}{x^2-9}$

11. $\frac{x^3-6x^2+9x}{x^3-3x^2}$

12. $\frac{y^5-5y^4+4y^3}{y^3-6y^2+8y}$

13. $\frac{6y^2+12y-48}{3y^2-9y+6}$

14. $\frac{2x^2-20x+50}{10x^2-30x-100}$

15. $\frac{4-x}{x^2+4x-32}$

16. $\frac{6-x}{x^2-36}$

Multiply or divide and, if possible, simplify.

17. $\frac{r-s}{r+s} \cdot \frac{r^2-s^2}{(r-s)^2}$

18. $\frac{x^2-y^2}{(x-y)^2} \cdot \frac{1}{x+y}$

19. $\frac{x^2+2x-35}{3x^3-2x^2} \cdot \frac{9x^3-4x}{7x+49}$

20. $\frac{x^2-2x-35}{2x^3-3x^2} \cdot \frac{4x^3-9x}{7x-49}$

21. $\frac{a^2-a-6}{a^2-7a+12} \cdot \frac{a^2-2a-8}{a^2-3a-10}$

22. $\frac{a^2-a-12}{a^2-6a+8} \cdot \frac{a^2+a-6}{a^2-2a-24}$

23. $\frac{m^2-n^2}{r+s} \div \frac{m-n}{r+s}$

24. $\frac{a^2-b^2}{x-y} \div \frac{a+b}{x-y}$

25. $\frac{3x+12}{2x-8} \div \frac{(x+4)^2}{(x-4)^2}$

26. $\frac{a^2-a-2}{a^2-a-6} \div \frac{a^2-2a}{2a+a^2}$

27. $\frac{x^2-y^2}{x^3-y^3} \cdot \frac{x^2+xy+y^2}{x^2+2xy+y^2}$

28. $\frac{c^3+8}{c^2-4} \div \frac{c^2-2c+4}{c^2-4c+4}$

29. $\frac{(x-y)^2-z^2}{(x+y)^2-z^2} \div \frac{x-y+z}{x+y-z}$

30. $\frac{(a+b)^2-9}{(a-b)^2-9} \cdot \frac{a-b-3}{a+b+3}$

Add or subtract and, if possible, simplify.

31. $\frac{7}{5x} + \frac{3}{5x}$

32. $\frac{7}{12y} - \frac{1}{12y}$

33. $\frac{4}{3a+4} + \frac{3a}{3a+4}$

34. $\frac{a-3b}{a+b} + \frac{a+5b}{a+b}$

35. $\frac{5}{4z} - \frac{3}{8z}$

36. $\frac{12}{x^2y} + \frac{5}{xy^2}$

37. $\frac{3}{x+2} + \frac{2}{x^2-4}$

38. $\frac{5}{a-3} - \frac{2}{a^2-9}$

39. $\frac{y}{y^2-y-20} - \frac{2}{y+4}$

40. $\frac{6}{y^2+6y+9} - \frac{5}{y+3}$

41. $\frac{3}{x+y} + \frac{x-5y}{x^2-y^2}$

42. $\frac{a^2+1}{a^2-1} - \frac{a-1}{a+1}$

43. $\frac{y}{y-1} + \frac{2}{1-y}$
(Note: $1-y = -1(y-1)$.)

44. $\frac{a}{a-b} + \frac{b}{b-a}$
(Note: $b-a = -1(a-b)$.)

45. $\frac{x}{2x-3y} - \frac{y}{3y-2x}$

46. $\frac{3a}{3a-2b} - \frac{2a}{2b-3a}$

47. $\frac{9x+2}{3x^2-2x-8} + \frac{7}{3x^2+x-4}$

48. $\frac{3y}{y^2-7y+10} - \frac{2y}{y^2-8y+15}$

49. $\frac{5a}{a-b} + \frac{ab}{a^2-b^2} + \frac{4b}{a+b}$

50. $\frac{6a}{a-b} - \frac{3b}{b-a} + \frac{5}{a^2-b^2}$

51. $\frac{7}{x+2} - \frac{x+8}{4-x^2} + \frac{3x-2}{4-4x+x^2}$

52. $\frac{6}{x+3} - \frac{x+4}{9-x^2} + \frac{2x-3}{9-6x+x^2}$

53. $\frac{1}{x+1} + \frac{x}{2-x} + \frac{x^2+2}{x^2-x-2}$

54. $\frac{x-1}{x-2} - \frac{x+1}{x+2} - \frac{x-6}{4-x^2}$

Simplify.

55. $\frac{\frac{a-b}{b}}{a^2-b^2} \cdot \frac{ab}{ab}$

56. $\frac{\frac{x^2-y^2}{xy}}{\frac{x-y}{y}}$

57. $\frac{\frac{x-y}{y} - \frac{y-x}{x}}{\frac{1}{y} + \frac{1}{x}}$

58. $\frac{\frac{a-b}{b} - \frac{b-a}{a}}{\frac{1}{a} - \frac{1}{b}}$

59. $\frac{c + \frac{8}{c^2}}{1 + \frac{2}{c}}$

60. $\frac{a - \frac{a}{b}}{b - \frac{b}{a}}$

61. $\frac{x^2+xy+y^2}{\frac{x^2}{y} - \frac{y^2}{x}}$

62. $\frac{\frac{a^2}{b} + \frac{b^2}{a}}{a^2-ab+b^2}$

63. $\frac{a-a^{-1}}{a+a^{-1}}$

64. $\frac{x^{-1}+y^{-1}}{x^{-3}+y^{-3}}$

65. $\frac{\frac{1}{x-3} + \frac{2}{x+3}}{\frac{3}{x-1} - \frac{4}{x+2}}$

67. $\frac{\frac{a}{1-a} + \frac{1+a}{a}}{\frac{1-a}{a} + \frac{a}{1+a}}$

69. $\frac{\frac{1}{a^2} + \frac{2}{ab} + \frac{1}{b^2}}{\frac{1}{a^2} - \frac{1}{b^2}}$

66. $\frac{\frac{5}{x+1} - \frac{3}{x-2}}{\frac{1}{x-5} + \frac{2}{x+2}}$

68. $\frac{\frac{1-x}{x} + \frac{x}{1+x}}{\frac{1+x}{x} + \frac{x}{1-x}}$

70. $\frac{\frac{1}{x^2} - \frac{1}{y^2}}{\frac{1}{x^2} - \frac{2}{xy} + \frac{1}{y^2}}$

Synthesis

Simplify.

71. $\frac{(x+h)^2 - x^2}{h}$

72. $\frac{\frac{1}{x+h} - \frac{1}{x}}{h}$

73. $\frac{(x+h)^3 - x^3}{h}$

74. $\frac{\frac{1}{(x+h)^2} - \frac{1}{x^2}}{h}$

75. $\left[\frac{\frac{x+1}{x-1} + 1}{\frac{x+1}{x-1} - 1} \right]^5$

76. $1 + \frac{1}{1 + \frac{1}{1 + \frac{1}{x}}}$

Perform the indicated operations and, if possible, simplify.

77. $\frac{n(n+1)(n+2)}{2 \cdot 3} + \frac{(n+1)(n+2)}{2}$

78. $\frac{n(n+1)(n+2)(n+3)}{2 \cdot 3 \cdot 4} + \frac{(n+1)(n+2)(n+3)}{2 \cdot 3}$

79. $\frac{x^2-9}{x^3+27} \cdot \frac{5x^2-15x+45}{x^2-2x-3} + \frac{x^2+x}{4+2x}$

80. $\frac{x^2+2x-3}{x^2-x-12} \div \frac{x^2-1}{x^2-16} - \frac{2x+1}{x^2+2x+1}$

Radical Notation and Rational Exponents

R.7

- ▶ Simplify radical expressions.
- ▶ Rationalize denominators or numerators in rational expressions.
- ▶ Convert between exponential notation and radical notation.
- ▶ Simplify expressions with rational exponents.

A number c is said to be a **square root** of a if $c^2 = a$. Thus, 3 is a square root of 9, because $3^2 = 9$, and -3 is also a square root of 9, because $(-3)^2 = 9$. Similarly, 5 is a third root (called a **cube root**) of 125, because $5^3 = 125$. The number 125 has no other real-number cube root.

*n*th Root

A number c is said to be an ***n*th root** of a if $c^n = a$.

The symbol \sqrt{a} denotes the nonnegative square root of a , and the symbol $\sqrt[3]{a}$ denotes the real-number cube root of a . The symbol $\sqrt[n]{a}$ denotes the n th root of a , that is, a number whose n th power is a . The symbol $\sqrt[n]{}$ is called a **radical**, and the expression under the radical is called the **radicand**. The number n (which is omitted when it is 2) is called the **index**. Examples of roots for $n = 2, 3$, and 4 are, respectively,

$$\sqrt{3600}, \quad \sqrt[3]{125}, \quad \text{and} \quad \sqrt[4]{16}.$$

Any real number has only one real-number odd root. Any positive number has two square roots, one positive and one negative. Similarly, for any even index, a positive number has two real-number roots. The positive root is called the **principal root**. When an expression such as $\sqrt{4}$ or $\sqrt[6]{23}$ is used, it is understood to represent the principal (nonnegative) root. To denote a negative root, we use $-\sqrt{4}$, $-\sqrt[6]{23}$, and so on.

EXAMPLE 1 Simplify each of the following.

- a) $\sqrt{36}$ b) $-\sqrt{36}$ c) $\sqrt[3]{-8}$
 d) $\sqrt[5]{\frac{32}{243}}$ e) $\sqrt[4]{-16}$

Solution

- a) $\sqrt{36} = 6$, because $6^2 = 36$.
 b) $-\sqrt{36} = -6$, because $6^2 = 36$ and $-(\sqrt{36}) = -(6) = -6$.
 c) $\sqrt[3]{-8} = -2$, because $(-2)^3 = -8$.

TECHNOLOGY CONNECTION

We can find $\sqrt{36}$ and $-\sqrt{36}$ in Example 1 using the square-root feature on the keypad of a graphing calculator, and we can use the cube-root feature to find $\sqrt[3]{-8}$. We can use the x th-root feature to find higher roots.

$\sqrt{(36)}$	6
$-\sqrt{(36)}$	-6

$\sqrt[3]{(-8)}$	-2
$5^x\sqrt{(32/243)} \blacktriangleright \text{Frac}$	2/3

When we try to find $\sqrt[4]{-16}$ on a graphing calculator set in REAL mode, we get an error message indicating that the answer is nonreal.

$4^x\sqrt{-16}$

ERR:NONREAL ANS 1: Quit 2: Goto

d) $\sqrt[5]{\frac{32}{243}} = \frac{2}{3}$, because $\left(\frac{2}{3}\right)^5 = \frac{2^5}{3^5} = \frac{32}{243}$.

e) $\sqrt[4]{-16}$ is not a real number, because we cannot find a real number that can be raised to the fourth power to get -16 .  **Now Try Exercise 11.**

We can generalize Example 1(e) and say that when a is negative and n is even, $\sqrt[n]{a}$ is not a real number. For example, $\sqrt{-4}$ and $\sqrt[4]{-81}$ are not real numbers.

► Simplifying Radical Expressions

Consider the expression $\sqrt{(-3)^2}$. This is equivalent to $\sqrt{9}$, or 3. Similarly, $\sqrt{3^2} = \sqrt{9} = 3$. This illustrates the first of several properties of radicals, listed below.

Properties of Radicals

Let a and b be any real numbers or expressions for which the given roots exist. For any natural numbers m and n ($n \neq 1$):

1. If n is even, $\sqrt[n]{a^n} = |a|$.
2. If n is odd, $\sqrt[n]{a^n} = a$.
3. $\sqrt[n]{a} \cdot \sqrt[n]{b} = \sqrt[n]{ab}$.
4. $\sqrt[n]{\frac{a}{b}} = \frac{\sqrt[n]{a}}{\sqrt[n]{b}}$ ($b \neq 0$).
5. $\sqrt[n]{a^m} = (\sqrt[n]{a})^m$.

EXAMPLE 2 Simplify each of the following.

- | | |
|------------------------------------|----------------------------|
| a) $\sqrt{(-5)^2}$ | b) $\sqrt[3]{(-5)^3}$ |
| c) $\sqrt[4]{4} \cdot \sqrt[4]{5}$ | d) $\sqrt{50}$ |
| e) $\frac{\sqrt{72}}{\sqrt{6}}$ | f) $\sqrt[3]{8^5}$ |
| g) $\sqrt{216x^5y^3}$ | h) $\sqrt{\frac{x^2}{16}}$ |

Solution

- a) $\sqrt{(-5)^2} = |-5| = 5$ **Using Property 1**
- b) $\sqrt[3]{(-5)^3} = -5$ **Using Property 2**
- c) $\sqrt[4]{4} \cdot \sqrt[4]{5} = \sqrt[4]{4 \cdot 5} = \sqrt[4]{20}$ **Using Property 3**
- d) $\sqrt{50} = \sqrt{25 \cdot 2} = \sqrt{25} \cdot \sqrt{2} = 5\sqrt{2}$ **Using Property 3**
- e) $\frac{\sqrt{72}}{\sqrt{6}} = \sqrt{\frac{72}{6}}$ **Using Property 4**
 $= \sqrt{12} = \sqrt{4 \cdot 3} = \sqrt{4} \cdot \sqrt{3}$ **Using Property 3**
 $= 2\sqrt{3}$

$$\begin{aligned} \text{f) } \sqrt[3]{8^5} &= (\sqrt[3]{8})^5 && \text{Using Property 5} \\ &= 2^5 = 32 \end{aligned}$$

$$\begin{aligned} \text{g) } \sqrt{216x^5y^3} &= \sqrt{36 \cdot 6 \cdot x^4 \cdot x \cdot y^2 \cdot y} \\ &= \sqrt{36x^4y^2} \sqrt{6xy} && \text{Using Property 3} \\ &= |6x^2y| \sqrt{6xy} && \text{Using Property 1} \\ &= 6x^2|y| \sqrt{6xy} && 6x^2 \text{ cannot be negative, so absolute-value signs are not needed for it.} \end{aligned}$$

$$\begin{aligned} \text{h) } \sqrt{\frac{x^2}{16}} &= \frac{\sqrt{x^2}}{\sqrt{16}} && \text{Using Property 4} \\ &= \frac{|x|}{4} && \text{Using Property 1} \end{aligned}$$

 **Now Try Exercise 19.**

In many situations, radicands are never formed by raising negative quantities to even powers. In such cases, absolute-value notation is not required. For this reason, **we will henceforth assume that no radicands are formed by raising negative quantities to even powers** and, consequently, we will not use absolute-value notation when we simplify radical expressions. For example, we will write $\sqrt{x^2} = x$ and $\sqrt[4]{a^5b} = a\sqrt[4]{ab}$.

Radical expressions with the same index and the same radicand can be combined (added or subtracted) in much the same way that we combine like terms.

EXAMPLE 3 Perform the operations indicated.

$$\text{a) } 3\sqrt{8x^2} - 5\sqrt{2x^2} \qquad \text{b) } (4\sqrt{3} + \sqrt{2})(\sqrt{3} - 5\sqrt{2})$$

Solution

$$\begin{aligned} \text{a) } 3\sqrt{8x^2} - 5\sqrt{2x^2} &= 3\sqrt{4x^2 \cdot 2} - 5\sqrt{x^2 \cdot 2} \\ &= 3 \cdot 2x\sqrt{2} - 5x\sqrt{2} \\ &= 6x\sqrt{2} - 5x\sqrt{2} \\ &= (6x - 5x)\sqrt{2} && \text{Using the distributive property} \\ &= x\sqrt{2} \end{aligned}$$

$$\begin{aligned} \text{b) } (4\sqrt{3} + \sqrt{2})(\sqrt{3} - 5\sqrt{2}) &= 4(\sqrt{3})^2 - 20\sqrt{6} + \sqrt{6} - 5(\sqrt{2})^2 \\ &= 4 \cdot 3 + (-20 + 1)\sqrt{6} - 5 \cdot 2 && \text{Multiplying} \\ &= 12 - 19\sqrt{6} - 10 \\ &= 2 - 19\sqrt{6} \end{aligned}$$

 **Now Try Exercises 45 and 51.**

An Application

The Pythagorean theorem relates the lengths of the sides of a right triangle. The side opposite the triangle's right angle is called the **hypotenuse**. The other sides are the **legs**.

The Pythagorean Theorem

The sum of the squares of the lengths of the legs of a right triangle is equal to the square of the length of the hypotenuse:

$$a^2 + b^2 = c^2.$$

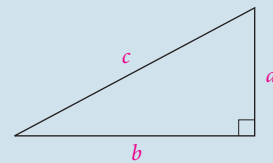

EXAMPLE 4 *Building a Doll House.* Roy is building a doll house for his granddaughter. The doll house measures 26 in. across, and the slanted side of the roof measures 15 in. Find the height of the roof.

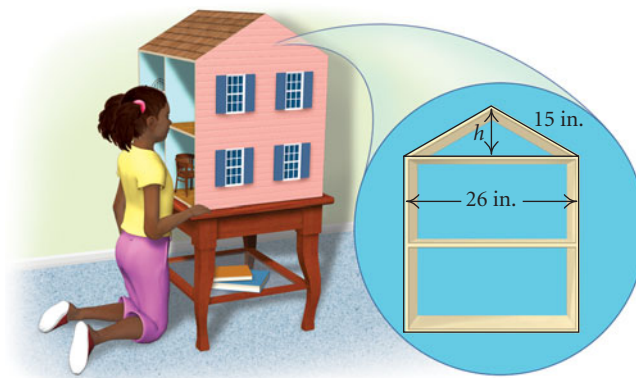

Solution We have a right triangle with hypotenuse 15 in. and one leg that measures $26/2$, or 13 in. We use the Pythagorean theorem to find the length of the other leg:

$$c^2 = a^2 + b^2$$

$$15^2 = 13^2 + h^2 \quad \text{Substituting 15 for } c, 13 \text{ for } a, \text{ and } h \text{ for } b$$

$$225 = 169 + h^2$$

$$56 = h^2$$

$$\sqrt{56} = h$$

$$7.5 \approx h.$$

The height of the roof is about 7.5 in.

Now Try Exercise 59.

► Rationalizing Denominators or Numerators

There are times when we need to remove the radicals in a denominator or a numerator. This is called **rationalizing the denominator** or **rationalizing the numerator**. It is done by multiplying by 1 in such a way as to obtain a perfect n th power.

EXAMPLE 5 Rationalize the denominator of each of the following.

a) $\sqrt{\frac{3}{2}}$

b) $\frac{\sqrt[3]{7}}{\sqrt[3]{9}}$

Solution

$$\begin{aligned} \text{a) } \sqrt{\frac{3}{2}} &= \sqrt{\frac{3 \cdot 2}{2 \cdot 2}} = \sqrt{\frac{6}{4}} = \frac{\sqrt{6}}{\sqrt{4}} = \frac{\sqrt{6}}{2} \\ \text{b) } \frac{\sqrt[3]{7}}{\sqrt[3]{9}} &= \frac{\sqrt[3]{7}}{\sqrt[3]{9}} \cdot \frac{\sqrt[3]{3}}{\sqrt[3]{3}} = \frac{\sqrt[3]{21}}{\sqrt[3]{27}} = \frac{\sqrt[3]{21}}{3} \end{aligned}$$

 **Now Try Exercise 65.**

Pairs of expressions of the form $a\sqrt{b} + c\sqrt{d}$ and $a\sqrt{b} - c\sqrt{d}$ are called **conjugates**. The product of such a pair contains no radicals and can be used to rationalize a denominator or a numerator.

EXAMPLE 6 Rationalize the numerator: $\frac{\sqrt{x} - \sqrt{y}}{5}$.

Solution

$$\begin{aligned} \frac{\sqrt{x} - \sqrt{y}}{5} &= \frac{\sqrt{x} - \sqrt{y}}{5} \cdot \frac{\sqrt{x} + \sqrt{y}}{\sqrt{x} + \sqrt{y}} \\ &= \frac{(\sqrt{x})^2 - (\sqrt{y})^2}{5\sqrt{x} + 5\sqrt{y}} \\ &= \frac{x - y}{5\sqrt{x} + 5\sqrt{y}} \end{aligned}$$

The conjugate of
 $\sqrt{x} - \sqrt{y}$ is $\sqrt{x} + \sqrt{y}$.
 $(A + B)(A - B) =$
 $A^2 - B^2$

 **Now Try Exercise 85.**

► Rational Exponents

We are motivated to define *rational exponents* so that the properties for integer exponents hold for them as well. For example, we must have

$$a^{1/2} \cdot a^{1/2} = a^{1/2+1/2} = a^1 = a.$$

Thus we are led to define $a^{1/2}$ to mean \sqrt{a} . Similarly, $a^{1/n}$ means $\sqrt[n]{a}$. Again, if the laws of exponents are to hold, we must have

$$(a^{1/n})^m = (a^m)^{1/n} = a^{m/n}.$$

Thus we are led to define $a^{m/n}$ to mean $\sqrt[n]{a^m}$, or, equivalently, $(\sqrt[n]{a})^m$.

Rational Exponents

For any real number a and any natural numbers m and n , $n \neq 1$, for which $\sqrt[n]{a}$ exists,

$$\begin{aligned} a^{1/n} &= \sqrt[n]{a}, \\ a^{m/n} &= \sqrt[n]{a^m} = (\sqrt[n]{a})^m, \quad \text{and} \\ a^{-m/n} &= \frac{1}{a^{m/n}}, \quad a \neq 0. \end{aligned}$$

We can use the definition of rational exponents to convert between radical notation and exponential notation.

EXAMPLE 7 Convert to radical notation and, if possible, simplify each of the following.

a) $7^{3/4}$ b) $8^{-5/3}$ c) $m^{1/6}$ d) $(-32)^{2/5}$

Solution

a) $7^{3/4} = \sqrt[4]{7^3}$, or $(\sqrt[4]{7})^3$

b) $8^{-5/3} = \frac{1}{8^{5/3}} = \frac{1}{(\sqrt[3]{8})^5} = \frac{1}{2^5} = \frac{1}{32}$

c) $m^{1/6} = \sqrt[6]{m}$

d) $(-32)^{2/5} = \sqrt[5]{(-32)^2} = \sqrt[5]{1024} = 4$, or
 $(-32)^{2/5} = (\sqrt[5]{-32})^2 = (-2)^2 = 4$

➔ Now Try Exercise 87.

EXAMPLE 8 Convert each of the following to exponential notation.

a) $(\sqrt[4]{7xy})^5$ b) $\sqrt[6]{x^3}$

Solution

a) $(\sqrt[4]{7xy})^5 = (7xy)^{5/4}$

b) $\sqrt[6]{x^3} = x^{3/6} = x^{1/2}$

➔ Now Try Exercise 97.

We can use the laws of exponents to simplify exponential expressions and radical expressions.

EXAMPLE 9 Simplify and then, if appropriate, write radical notation for each of the following.

a) $x^{5/6} \cdot x^{2/3}$ b) $(x + 3)^{5/2}(x + 3)^{-1/2}$ c) $\sqrt[3]{\sqrt{7}}$

Solution

a) $x^{5/6} \cdot x^{2/3} = x^{5/6+2/3} = x^{9/6} = x^{3/2} = \sqrt{x^3} = \sqrt{x^2} \sqrt{x} = x\sqrt{x}$

b) $(x + 3)^{5/2}(x + 3)^{-1/2} = (x + 3)^{5/2-1/2} = (x + 3)^2$

c) $\sqrt[3]{\sqrt{7}} = \sqrt[3]{7^{1/2}} = (7^{1/2})^{1/3} = 7^{1/6} = \sqrt[6]{7}$

➔ Now Try Exercise 107.

EXAMPLE 10 Write an expression containing a single radical: $\sqrt{a}\sqrt[6]{b^5}$.

Solution $\sqrt{a}\sqrt[6]{b^5} = a^{1/2}b^{5/6} = a^{3/6}b^{5/6} = (a^3b^5)^{1/6} = \sqrt[6]{a^3b^5}$

➔ Now Try Exercise 117.

TECHNOLOGY CONNECTION

We can add and subtract rational exponents on a graphing calculator. The FRAC feature from the MATH menu allows us to express the result as a fraction. The addition of the exponents in Example 9(a) is shown here.

5/6+2/3▶Frac

3/2

R.7

Exercise Set

Simplify. Assume that variables can represent any real number.

1. $\sqrt{(-21)^2}$

2. $\sqrt{(-7)^2}$

3. $\sqrt{9y^2}$

4. $\sqrt{64t^2}$

5. $\sqrt{(a-2)^2}$

7. $\sqrt[3]{-27x^3}$

9. $\sqrt[4]{81x^8}$

6. $\sqrt{(2b+5)^2}$

8. $\sqrt[3]{-8y^3}$

10. $\sqrt[4]{16z^{12}}$

11. $\sqrt[5]{32}$ 12. $\sqrt[5]{-32}$
 13. $\sqrt{180}$ 14. $\sqrt{48}$
 15. $\sqrt{72}$ 16. $\sqrt{250}$
 17. $\sqrt[3]{54}$ 18. $\sqrt[3]{135}$
 19. $\sqrt{128c^2d^4}$ 20. $\sqrt{162c^4d^6}$
 21. $\sqrt[4]{48x^6y^4}$ 22. $\sqrt[4]{243m^5n^{10}}$
 23. $\sqrt{x^2 - 4x + 4}$ 24. $\sqrt{x^2 + 16x + 64}$

Simplify. Assume that no radicands were formed by raising negative quantities to even powers.

25. $\sqrt{15}\sqrt{35}$ 26. $\sqrt{21}\sqrt{6}$
 27. $\sqrt{8}\sqrt{10}$ 28. $\sqrt{12}\sqrt{15}$
 29. $\sqrt{2x^3y}\sqrt{12xy}$ 30. $\sqrt{3y^4z}\sqrt{20z}$
 31. $\sqrt[3]{3x^2y}\sqrt[3]{36x}$ 32. $\sqrt[5]{8x^3y^4}\sqrt[5]{4x^4y}$
 33. $\sqrt[3]{2(x+4)}\sqrt[3]{4(x+4)^4}$
 34. $\sqrt[3]{4(x+1)^2}\sqrt[3]{18(x+1)^2}$
 35. $\sqrt[8]{\frac{m^{16}n^{24}}{2^8}}$ 36. $\sqrt[6]{\frac{m^{12}n^{24}}{64}}$
 37. $\frac{\sqrt{40xy}}{\sqrt{8x}}$ 38. $\frac{\sqrt[3]{40m}}{\sqrt[3]{5m}}$
 39. $\frac{\sqrt[3]{3x^2}}{\sqrt[3]{24x^5}}$ 40. $\frac{\sqrt{128a^2b^4}}{\sqrt{16ab}}$
 41. $\sqrt[3]{\frac{64a^4}{27b^3}}$ 42. $\sqrt{\frac{9x^7}{16y^8}}$
 43. $\sqrt{\frac{7x^3}{36y^6}}$ 44. $\sqrt[3]{\frac{2yz}{250z^4}}$
 45. $5\sqrt{2} + 3\sqrt{32}$ 46. $7\sqrt{12} - 2\sqrt{3}$
 47. $6\sqrt{20} - 4\sqrt{45} + \sqrt{80}$
 48. $2\sqrt{32} + 3\sqrt{8} - 4\sqrt{18}$
 49. $8\sqrt{2x^2} - 6\sqrt{20x} - 5\sqrt{8x^2}$
 50. $2\sqrt[3]{8x^2} + 5\sqrt[3]{27x^2} - 3\sqrt{x^3}$
 51. $(\sqrt{8} + 2\sqrt{5})(\sqrt{8} - 2\sqrt{5})$
 52. $(\sqrt{3} - \sqrt{2})(\sqrt{3} + \sqrt{2})$
 53. $(2\sqrt{3} + \sqrt{5})(\sqrt{3} - 3\sqrt{5})$
 54. $(\sqrt{6} - 4\sqrt{7})(3\sqrt{6} + 2\sqrt{7})$

55. $(\sqrt{2} - 5)^2$ 56. $(1 + \sqrt{3})^2$
 57. $(\sqrt{5} - \sqrt{6})^2$ 58. $(\sqrt{3} + \sqrt{2})^2$

59. **Surveying.** A surveyor places poles at points A, B, and C in order to measure the distance across a pond. The distances AC and BC are measured as shown. Find the distance AB across the pond.

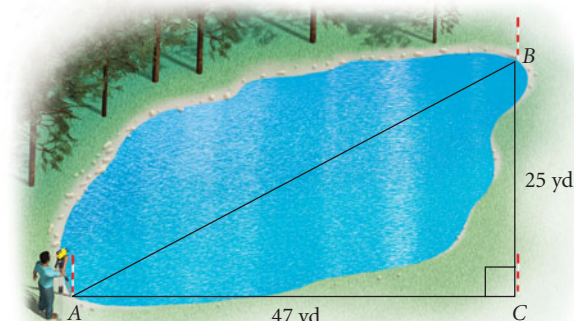

60. **Distance from Airport.** An airplane is flying at an altitude of 3700 ft. The slanted distance directly to the airport is 14,200 ft. How far horizontally is the airplane from the airport?



61. An equilateral triangle is shown below.

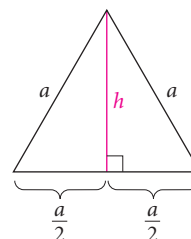

- a) Find an expression for its height h in terms of a .
 b) Find an expression for its area A in terms of a .
62. An isosceles right triangle has legs of length s . Find an expression for the length of the hypotenuse in terms of s .

63. The diagonal of a square has length $8\sqrt{2}$. Find the length of a side of the square.
64. The area of square PQRS is 100 ft^2 , and A, B, C, and D are the midpoints of the sides. Find the area of square ABCD.

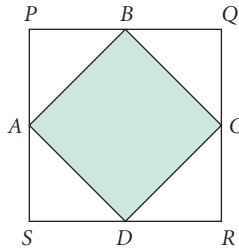

Rationalize the denominator.

- | | |
|---|---|
| 65. $\frac{\sqrt{3}}{\sqrt{7}}$ | 66. $\frac{\sqrt{2}}{\sqrt{3}}$ |
| 67. $\frac{\sqrt[3]{7}}{\sqrt[3]{25}}$ | 68. $\frac{\sqrt[3]{5}}{\sqrt[3]{4}}$ |
| 69. $\frac{\sqrt[3]{16}}{\sqrt{9}}$ | 70. $\frac{\sqrt[3]{3}}{\sqrt{5}}$ |
| 71. $\frac{2}{\sqrt{3}-1}$ | 72. $\frac{6}{3+\sqrt{5}}$ |
| 73. $\frac{1-\sqrt{2}}{2\sqrt{3}-\sqrt{6}}$ | 74. $\frac{\sqrt{5}+4}{\sqrt{2}+3\sqrt{7}}$ |
| 75. $\frac{6}{\sqrt{m}-\sqrt{n}}$ | 76. $\frac{3}{\sqrt{v}+\sqrt{w}}$ |

Rationalize the numerator.

- | | |
|-------------------------------------|--|
| 77. $\frac{\sqrt{50}}{3}$ | 78. $\frac{\sqrt{12}}{5}$ |
| 79. $\frac{\sqrt[3]{2}}{\sqrt{5}}$ | 80. $\frac{\sqrt[3]{7}}{\sqrt{2}}$ |
| 81. $\frac{\sqrt{11}}{\sqrt{3}}$ | 82. $\frac{\sqrt{5}}{\sqrt{2}}$ |
| 83. $\frac{9-\sqrt{5}}{3-\sqrt{3}}$ | 84. $\frac{8-\sqrt{6}}{5-\sqrt{2}}$ |
| 85. $\frac{\sqrt{a}+\sqrt{b}}{3a}$ | 86. $\frac{\sqrt{p}-\sqrt{q}}{1+\sqrt{q}}$ |

Convert to radical notation and, if possible, simplify.

- | | |
|----------------|---------------|
| 87. $y^{5/6}$ | 88. $x^{2/3}$ |
| 89. $16^{3/4}$ | 90. $4^{7/2}$ |

- | | |
|-----------------------|-----------------------|
| 91. $125^{-1/3}$ | 92. $32^{-4/5}$ |
| 93. $a^{5/4}b^{-3/4}$ | 94. $x^{2/5}y^{-1/5}$ |
| 95. $m^{5/3}n^{7/3}$ | 96. $p^{7/6}q^{11/6}$ |

Convert to exponential notation.

- | | |
|----------------------------|------------------------------|
| 97. $\sqrt[5]{17^3}$ | 98. $(\sqrt[4]{13})^5$ |
| 99. $(\sqrt[5]{12})^4$ | 100. $\sqrt[3]{20^2}$ |
| 101. $\sqrt[3]{\sqrt{11}}$ | 102. $\sqrt[3]{\sqrt[4]{7}}$ |
| 103. $\sqrt{5}\sqrt[3]{5}$ | 104. $\sqrt[3]{2}\sqrt{2}$ |
| 105. $\sqrt[5]{32^2}$ | 106. $\sqrt[3]{64^2}$ |

Simplify and then, if appropriate, write radical notation.

- | | |
|---|--|
| 107. $(2a^{3/2})(4a^{1/2})$ | 108. $(3a^{5/6})(8a^{2/3})$ |
| 109. $(\frac{x^6}{9b^{-4}})^{1/2}$ | 110. $(\frac{x^{2/3}}{4y^{-2}})^{1/2}$ |
| 111. $\frac{x^{2/3}y^{5/6}}{x^{-1/3}y^{1/2}}$ | 112. $\frac{a^{1/2}b^{5/8}}{a^{1/4}b^{3/8}}$ |
| 113. $(m^{1/2}n^{5/2})^{2/3}$ | 114. $(x^{5/3}y^{1/3}z^{2/3})^{3/5}$ |
| 115. $a^{3/4}(a^{2/3}+a^{4/3})$ | 116. $m^{2/3}(m^{7/4}-m^{5/4})$ |

Write an expression containing a single radical and simplify.

- | | |
|--|--------------------------------|
| 117. $\sqrt[3]{6}\sqrt{2}$ | 118. $\sqrt{2}\sqrt[4]{8}$ |
| 119. $\sqrt[4]{xy}\sqrt[3]{x^2y}$ | 120. $\sqrt[3]{ab^2}\sqrt{ab}$ |
| 121. $\sqrt[3]{a^4}\sqrt{a^3}$ | 122. $\sqrt{a^3}\sqrt[3]{a^2}$ |
| 123. $\frac{\sqrt{(a+x)^3}\sqrt[3]{(a+x)^2}}{\sqrt[4]{a+x}}$ | |
| 124. $\frac{\sqrt[4]{(x+y)^2}\sqrt[3]{x+y}}{\sqrt{(x+y)^3}}$ | |

Synthesis

Simplify.

- | |
|--|
| 125. $\sqrt{1+x^2} + \frac{1}{\sqrt{1+x^2}}$ |
| 126. $\sqrt{1-x^2} - \frac{x^2}{2\sqrt{1-x^2}}$ |
| 127. $(\sqrt{a\sqrt{a}})^{\sqrt{a}}$ |
| 128. $(2a^3b^{5/4}c^{1/7})^4 \div (54a^{-2}b^{2/3}c^{6/5})^{-1/3}$ |

Chapter R Summary and Review

STUDY GUIDE

IMPORTANT PROPERTIES AND FORMULAS

Properties of the Real Numbers

<i>Commutative:</i>	$a + b = b + a;$ $ab = ba$
<i>Associative:</i>	$a + (b + c) = (a + b) + c;$ $a(bc) = (ab)c$
<i>Additive Identity:</i>	$a + 0 = 0 + a = a$
<i>Additive Inverse:</i>	$-a + a = a + (-a) = 0$
<i>Multiplicative Identity:</i>	$a \cdot 1 = 1 \cdot a = a$
<i>Multiplicative Inverse:</i>	$a \cdot \frac{1}{a} = \frac{1}{a} \cdot a = 1 \quad (a \neq 0)$
<i>Distributive:</i>	$a(b + c) = ab + ac$

Absolute Value

For any real number a ,

$$|a| = \begin{cases} a, & \text{if } a \geq 0, \\ -a, & \text{if } a < 0. \end{cases}$$

Properties of Exponents

For any real numbers a and b and any integers m and n , assuming 0 is not raised to a nonpositive power:

<i>The Product Rule:</i>	$a^m \cdot a^n = a^{m+n}$
<i>The Quotient Rule:</i>	$\frac{a^m}{a^n} = a^{m-n} \quad (a \neq 0)$
<i>The Power Rule:</i>	$(a^m)^n = a^{mn}$
<i>Raising a Product to a Power:</i>	$(ab)^m = a^m b^m$
<i>Raising a Quotient to a Power:</i>	$\left(\frac{a}{b}\right)^m = \frac{a^m}{b^m} \quad (b \neq 0)$

Compound Interest Formula

$$A = P \left(1 + \frac{r}{n} \right)^{nt}$$

Special Products of Binomials

$$\begin{aligned} (A + B)^2 &= A^2 + 2AB + B^2 \\ (A - B)^2 &= A^2 - 2AB + B^2 \\ (A + B)(A - B) &= A^2 - B^2 \end{aligned}$$

Sum or Difference of Cubes

$$\begin{aligned} A^3 + B^3 &= (A + B)(A^2 - AB + B^2) \\ A^3 - B^3 &= (A - B)(A^2 + AB + B^2) \end{aligned}$$

Equation-Solving Principles

The Addition Principle: If $a = b$ is true, then $a + c = b + c$ is true.

The Multiplication Principle: If $a = b$ is true, then $ac = bc$ is true.

The Principle of Zero Products: If $ab = 0$ is true, then $a = 0$ or $b = 0$, and if $a = 0$ or $b = 0$, then $ab = 0$.

The Principle of Square Roots: If $x^2 = k$, then $x = \sqrt{k}$ or $x = -\sqrt{k}$.

Properties of Radicals

Let a and b be any real numbers or expressions for which the given roots exist. For any natural numbers m and n ($n \neq 1$):

$$\text{If } n \text{ is even, } \sqrt[n]{a^n} = |a|.$$

$$\text{If } n \text{ is odd, } \sqrt[n]{a^n} = a.$$

$$\sqrt[n]{a} \cdot \sqrt[n]{b} = \sqrt[n]{ab}.$$

$$\sqrt[n]{\frac{a}{b}} = \frac{\sqrt[n]{a}}{\sqrt[n]{b}} \quad (b \neq 0).$$

$$\sqrt[n]{a^m} = (\sqrt[n]{a})^m.$$

Pythagorean Theorem

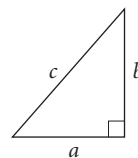

$$a^2 + b^2 = c^2$$

Rational Exponents

For any real number a and any natural numbers m and n , $n \neq 1$, for which $\sqrt[n]{a}$ exists,

$$a^{1/n} = \sqrt[n]{a},$$

$$a^{m/n} = \sqrt[n]{a^m} = (\sqrt[n]{a})^m, \quad \text{and}$$

$$a^{-m/n} = \frac{1}{a^{m/n}}, \quad a \neq 0.$$

REVIEW EXERCISES

Answers for all the review exercises appear in the answer section at the back of the book. If your answer is incorrect, reread the section indicated in red next to the exercise or the direction line that precedes it.

Determine whether the statement is true or false.

- If $a < 0$, then $|a| = -a$. [R.1]
- For any real number a , $a \neq 0$, and any integers m and n , $a^m \cdot a^n = a^{mn}$. [R.2]
- If $a = b$ is true, then $a + c = b + c$ is true. [R.5]
- The domain of an algebraic expression is the set of all real numbers for which the expression is defined. [R.6]

In Exercises 5–10, consider the following numbers

$$-7, 43, -\frac{4}{9}, \sqrt{17}, 0, 2.191191119\dots, \sqrt[3]{64},$$

$$-\sqrt{2}, 4\frac{3}{4}, \frac{12}{7}, 102, \sqrt[5]{5}.$$

- Which are rational numbers? [R.1]
- Which are whole numbers? [R.1]
- Which are integers? [R.1]
- Which are real numbers? [R.1]
- Which are natural numbers? [R.1]
- Which are irrational numbers? [R.1]
- Write interval notation for $\{x \mid -4 < x \leq 7\}$. [R.1]

Simplify. [R.1]

$$12. |24| \qquad 13. \left| -\frac{7}{8} \right|$$

- Find the distance between -5 and 5 on the number line. [R.1]

Calculate. [R.2]

$$15. 3 \cdot 2 - 4 \cdot 2^2 + 6(3 - 1)$$

$$16. \frac{3^4 - (6 - 7)^4}{2^3 - 2^4}$$

Convert to decimal notation. [R.2]

$$17. 8.3 \times 10^{-5}$$

$$18. 2.07 \times 10^7$$

Convert to scientific notation. [R.2]

$$19. 405,000$$

$$20. 0.00000039$$

Compute. Write the answer using scientific notation. [R.2]

$$21. (3.1 \times 10^5)(4.5 \times 10^{-3})$$

$$22. \frac{2.5 \times 10^{-8}}{3.2 \times 10^{13}}$$

Simplify.

$$23. (-3x^4y^{-5})(4x^{-2}y) \text{ [R.2]}$$

$$24. \frac{48a^{-3}b^2c^5}{6a^3b^{-1}c^4} \text{ [R.2]}$$

$$25. \sqrt[4]{81} \text{ [R.7]}$$

$$26. \sqrt[5]{-32} \text{ [R.7]}$$

$$27. \frac{b - a^{-1}}{a - b^{-1}} \text{ [R.6]}$$

$$28. \frac{\frac{x^2}{y} + \frac{y^2}{x}}{y^2 - xy + x^2} \text{ [R.6]}$$

$$29. (\sqrt{3} - \sqrt{7})(\sqrt{3} + \sqrt{7}) \text{ [R.7]}$$

$$30. (5 - \sqrt{2})^2 \text{ [R.7]}$$

$$31. 8\sqrt{5} + \frac{25}{\sqrt{5}} \text{ [R.7]}$$

$$32. (x + t)(x^2 - xt + t^2) \text{ [R.3]}$$

$$33. (5a + 4b)(2a - 3b) \text{ [R.3]}$$

$$34. (6x^2y - 3xy^2 + 5xy - 3) - (-4x^2y - 4xy^2 + 3xy + 8) \text{ [R.3]}$$

Factor. [R.4]

35. $32x^4 - 40xy^3$
 36. $y^3 + 3y^2 - 2y - 6$
 37. $24x + 144 + x^2$
 38. $9x^3 + 35x^2 - 4x$
 39. $9x^2 - 30x + 25$
 40. $8x^3 - 1$
 41. $18x^2 - 3x + 6$
 42. $4x^3 - 4x^2 - 9x + 9$
 43. $6x^3 + 48$
 44. $a^2b^2 - ab - 6$
 45. $2x^2 + 5x - 3$

Solve. [R.5]

46. $2x - 7 = 7$
 47. $5x - 7 = 3x - 9$
 48. $8 - 3x = -7 + 2x$
 49. $6(2x - 1) = 3 - (x + 10)$
 50. $y^2 + 16y + 64 = 0$
 51. $x^2 - x = 20$
 52. $2x^2 + 11x - 6 = 0$
 53. $x(x - 2) = 3$
 54. $y^2 - 16 = 0$
 55. $n^2 - 7 = 0$

56. Divide and simplify:

$$\frac{3x^2 - 12}{x^2 + 4x + 4} \div \frac{x - 2}{x + 2}. \quad [\text{R.6}]$$

57. Subtract and simplify:

$$\frac{x}{x^2 + 9x + 20} - \frac{4}{x^2 + 7x + 12}. \quad [\text{R.6}]$$

Write an expression containing a single radical. [R.7]

58. $\sqrt{y^5} \sqrt[3]{y^2}$

59. $\frac{\sqrt{(a+b)^3} \sqrt[3]{a+b}}{\sqrt[6]{(a+b)^7}}$

60. Convert to radical notation: $b^{7/5}$. [R.7]

61. Convert to exponential notation:

$$\sqrt[8]{m^{32}n^{16}}. \quad [\text{R.7}]$$

62. Rationalize the denominator:

$$\frac{4 - \sqrt{3}}{5 + \sqrt{3}}. \quad [\text{R.7}]$$

63. How long is a guy wire that reaches from the top of a 17-ft pole to a point on the ground 8 ft from the bottom of the pole? [R.7]

64. Calculate: $128 \div (-2)^3 \div (-2) \cdot 3$. [R.2]

A. $\frac{8}{3}$ B. 24 C. 96 D. $\frac{512}{3}$

65. Factor completely: $9x^2 - 36y^2$. [R.4]

- A. $(3x + 6y)(3x - 6y)$
 B. $3(x + 2y)(x - 2y)$
 C. $9(x + 2y)(x - 2y)$
 D. $9(x - 2y)^2$

Synthesis

Mortgage Payments. The formula

$$M = P \left[\frac{\frac{r}{12} \left(1 + \frac{r}{12} \right)^n}{\left(1 + \frac{r}{12} \right)^n - 1} \right]$$

gives the monthly mortgage payment M on a home loan of P dollars at interest rate r , where n is the total number of payments (12 times the number of years). Use this formula in Exercises 66–69. [R.2]

66. The cost of a house is \$98,000. The down payment is \$16,000, the interest rate is $6\frac{1}{2}\%$, and the loan period is 25 years. What is the monthly mortgage payment?

67. The cost of a house is \$124,000. The down payment is \$20,000, the interest rate is $5\frac{3}{4}\%$, and the loan period is 30 years. What is the monthly mortgage payment?
68. The cost of a house is \$135,000. The down payment is \$18,000, the interest rate is $7\frac{1}{2}\%$, and the loan period is 20 years. What is the monthly mortgage payment?
69. The cost of a house is \$151,000. The down payment is \$21,000, the interest rate is $6\frac{1}{4}\%$, and the loan period is 25 years. What is the monthly mortgage payment?

Multiply. Assume that all exponents are integers. [R.3]

70. $(x^n + 10)(x^n - 4)$

71. $(t^a + t^{-a})^2$

72. $(y^b - z^c)(y^b + z^c)$

73. $(a^n - b^n)^3$

Factor. [R.4]

74. $y^{2n} + 16y^n + 64$

75. $x^{2t} - 3x^t - 28$

76. $m^{6n} - m^{3n}$

Collaborative Discussion and Writing

To the student and the instructor: The Collaborative Discussion and Writing exercises are meant to be answered with one or more sentences. These exercises can also be discussed and answered collaboratively by the entire class or by small groups. Answers to these exercises appear at the back of the book.

77. Anya says that $15 - 6 \div 3 \cdot 4$ is 12. What mistake is she probably making? [R.2]
78. When adding or subtracting rational expressions, we can always find a common denominator by forming the product of all the denominators. Explain why it is usually preferable to find the least common denominator. [R.6]
79. Explain how the rule for factoring a sum of cubes can be used to factor a difference of cubes. [R.4]
80. Explain how you would determine whether $10\sqrt{26} - 50$ is positive or negative without carrying out the actual computation. [R.7]

Chapter R Test

1. Consider the numbers

$$6\frac{6}{7}, \sqrt{12}, 0, -\frac{13}{4}, \sqrt[3]{8}, -1.2, 29, -5.$$

- a) Which are whole numbers?
 b) Which are irrational numbers?
 c) Which are integers but not natural numbers?
 d) Which are rational numbers but not integers?

Simplify.

2. $|-17.6|$ 3. $\left|\frac{15}{11}\right|$ 4. $|0|$

5. Write interval notation for $\{x | -3 < x \leq 6\}$. Then graph the interval.
6. Find the distance between -9 and 6 on the number line.
7. Calculate: $32 \div 2^3 - 12 \div 4 \cdot 3$.

8. Convert to scientific notation: 4,509,000.

9. Convert to decimal notation: 8.6×10^{-5} .

10. Compute and write scientific notation for the answer:

$$\frac{2.7 \times 10^4}{3.6 \times 10^{-3}}$$

Simplify.

11. $x^{-8} \cdot x^5$
12. $(2y^2)^3(3y^4)^2$
13. $(-3a^5b^{-4})(5a^{-1}b^3)$
14. $(5xy^4 - 7xy^2 + 4x^2 - 3) - (-3xy^4 + 2xy^2 - 2y + 4)$
15. $(y - 2)(3y + 4)$
16. $(4x - 3)^2$

$$17. \frac{\frac{x}{y} - \frac{y}{x}}{x + y}$$

$$18. \sqrt{45}$$

$$19. \sqrt[3]{56}$$

$$20. 3\sqrt{75} + 2\sqrt{27}$$

$$21. \sqrt{18} \sqrt{10}$$

$$22. (2 + \sqrt{3})(5 - 2\sqrt{3})$$

Factor.

$$23. 8x^2 - 18$$

$$24. y^2 - 3y - 18$$

$$25. 2n^2 + 5n - 12$$

$$26. x^3 + 10x^2 + 25x$$

$$27. m^3 - 8$$

Solve.

$$28. 7x - 4 = 24$$

$$29. 3(y - 5) + 6 = 8 - (y + 2)$$

$$30. 2x^2 + 5x + 3 = 0$$

$$31. z^2 - 11 = 0$$

32. Multiply and simplify:

$$\frac{x^2 + x - 6}{x^2 + 8x + 15} \cdot \frac{x^2 - 25}{x^2 - 4x + 4}$$

33. Subtract and simplify:

$$\frac{x}{x^2 - 1} - \frac{3}{x^2 + 4x - 5}$$

34. Rationalize the denominator:

$$\frac{5}{7 - \sqrt{3}}$$

35. Convert to radical notation: $m^{3/8}$.

36. Convert to exponential notation: $\sqrt[6]{3^5}$.

37. How long is a guy wire that reaches from the top of a 12-ft pole to a point on the ground 5 ft from the bottom of the pole?

Synthesis

38. Multiply: $(x - y - 1)^2$.

This page intentionally left blank

Graphs, Functions, and Models

CHAPTER

1



Application

In the Dominican Republic, factory-bottled water is the primary source of drinking water for 67% of the urban population. In 2009, the population of the Dominican Republic was 9,650,054, of which 66.8% was urban (*Source: National Geographic*, April 2010). For how many in the urban population of the Dominican Republic was bottled water the primary source of drinking water?

This problem is Exercise 69 in Section 1.5.

1.1 Introduction to Graphing

Visualizing the Graph

1.2 Functions and Graphs

1.3 Linear Functions, Slope, and Applications

Visualizing the Graph

Mid-Chapter Mixed Review

1.4 Equations of Lines and Modeling

1.5 Linear Equations, Functions, Zeros, and Applications

1.6 Solving Linear Inequalities

Study Guide

Review Exercises

Chapter Test

Introduction to Graphing

1.1

- ▶ Plot points.
- ▶ Determine whether an ordered pair is a solution of an equation.
- ▶ Find the x - and y -intercepts of an equation of the form $Ax + By = C$.
- ▶ Graph equations.
- ▶ Find the distance between two points in the plane and find the midpoint of a segment.
- ▶ Find an equation of a circle with a given center and radius, and given an equation of a circle in standard form, find the center and the radius.
- ▶ Graph equations of circles.

▶ Graphs

Graphs provide a means of displaying, interpreting, and analyzing data in a visual format. It is not uncommon to open a newspaper or magazine and encounter graphs. Examples of line, circle, and bar graphs are shown below.

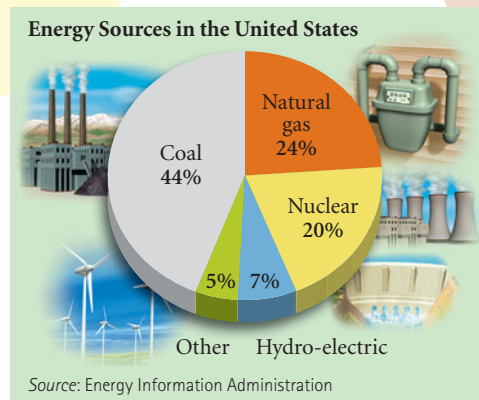
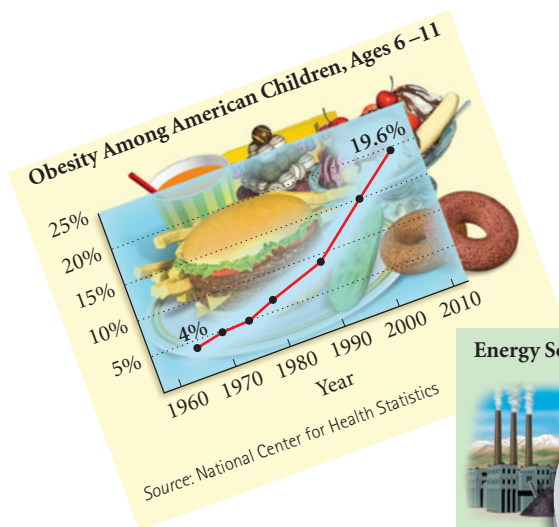

Many real-world situations can be modeled, or described mathematically, using equations in which two variables appear. We use a plane to graph a pair of numbers. To locate points on a plane, we use two perpendicular number lines, called **axes**, which intersect at $(0, 0)$. We call this point the

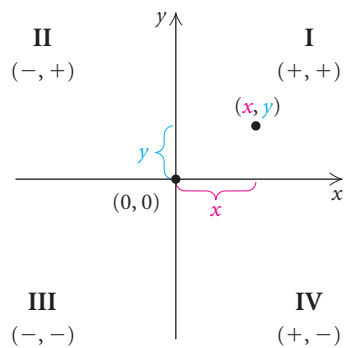

origin. The horizontal axis is called the **x -axis**, and the vertical axis is called the **y -axis**. (Other variables, such as a and b , can also be used.) The axes divide the plane into four regions, called **quadrants**, denoted by Roman numerals and numbered counterclockwise from the upper right. Arrows show the positive direction of each axis.

Each point (x, y) in the plane is described by an **ordered pair**. The first number, x , indicates the point's horizontal location with respect to the y -axis, and the second number, y , indicates the point's vertical location with respect to the x -axis. We call x the **first coordinate**, **x -coordinate**, or **abscissa**. We call y the **second coordinate**, **y -coordinate**, or **ordinate**. Such a representation is called the **Cartesian coordinate system** in honor of the French mathematician and philosopher René Descartes (1596–1650).

In the first quadrant, both coordinates of a point are positive. In the second quadrant, the first coordinate is negative and the second is positive. In the third quadrant, both coordinates are negative, and in the fourth quadrant, the first coordinate is positive and the second is negative.

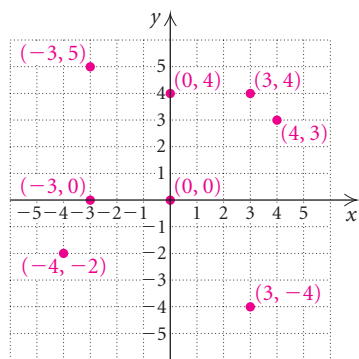

EXAMPLE 1 Graph and label the points $(-3, 5)$, $(4, 3)$, $(3, 4)$, $(-4, -2)$, $(3, -4)$, $(0, 4)$, $(-3, 0)$, and $(0, 0)$.

Solution To graph or **plot** $(-3, 5)$, we note that the x -coordinate, -3 , tells us to move from the origin 3 units to the left of the y -axis. Then we move 5 units up from the x -axis.* To graph the other points, we proceed in a similar manner. (See the graph at left.) Note that the point $(4, 3)$ is different from the point $(3, 4)$.

Now Try Exercise 3.

► Solutions of Equations

Equations in two variables, like $2x + 3y = 18$, have solutions (x, y) that are ordered pairs such that when the first coordinate is substituted for x and the second coordinate is substituted for y , the result is a true equation. The first coordinate in an ordered pair generally represents the variable that occurs first alphabetically.

EXAMPLE 2 Determine whether each ordered pair is a solution of $2x + 3y = 18$.

a) $(-5, 7)$

b) $(3, 4)$

Solution We substitute the ordered pair into the equation and determine whether the resulting equation is true.

$$\begin{array}{r|l} \text{a) } & 2x + 3y = 18 \\ & 2(-5) + 3(7) \quad ? \quad 18 \\ & -10 + 21 \\ & 11 \quad | \quad 18 \quad \text{FALSE} \end{array} \quad \begin{array}{l} \text{We substitute } -5 \text{ for } x \\ \text{and } 7 \text{ for } y \text{ (alphabetical order).} \end{array}$$

The equation $11 = 18$ is false, so $(-5, 7)$ is not a solution.

*We first saw notation such as $(-3, 5)$ in Section R.1. There the notation represented an open interval. Here the notation represents an ordered pair. The context in which the notation appears usually makes the meaning clear.

$$\begin{array}{r} \text{b) } \frac{2x + 3y = 18}{2(3) + 3(4) \quad ? \quad 18} \quad \text{We substitute 3 for } x \text{ and 4 for } y. \\ \quad \quad \quad 6 + 12 \quad | \\ \quad \quad \quad 18 \quad | \quad 18 \quad \text{TRUE} \end{array}$$

The equation $18 = 18$ is true, so $(3, 4)$ is a solution.

 **Now Try Exercise 11.**

► Graphs of Equations

The equation considered in Example 2 actually has an infinite number of solutions. Since we cannot list all the solutions, we will make a drawing, called a **graph**, that represents them. On the following page are some suggestions for drawing graphs.

To Graph an Equation

To **graph an equation** is to make a drawing that represents the solutions of that equation.

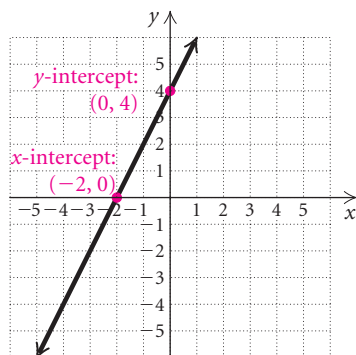

Graphs of equations of the type $Ax + By = C$ are straight lines. Many such equations can be graphed conveniently using intercepts. The **x-intercept** of the graph of an equation is the point at which the graph crosses the x -axis. The **y-intercept** is the point at which the graph crosses the y -axis. We know from geometry that only one line can be drawn through two given points. Thus, if we know the intercepts, we can graph the line. To ensure that a computational error has not been made, it is a good idea to calculate and plot a third point as a check.

x- and y-Intercepts

An **x-intercept** is a point $(a, 0)$. To find a , let $y = 0$ and solve for x .

A **y-intercept** is a point $(0, b)$. To find b , let $x = 0$ and solve for y .

EXAMPLE 3 Graph: $2x + 3y = 18$.

Solution The graph is a line. To find ordered pairs that are solutions of this equation, we can replace either x or y with any number and then solve for the other variable. In this case, it is convenient to find the intercepts of the graph. For instance, if x is replaced with 0, then

$$\begin{aligned} 2 \cdot 0 + 3y &= 18 \\ 3y &= 18 \\ y &= 6. \quad \text{Dividing by 3 on both sides} \end{aligned}$$

Thus, $(0, 6)$ is a solution. It is the y -intercept of the graph. If y is replaced with 0, then

$$2x + 3 \cdot 0 = 18$$

$$2x = 18$$

$$x = 9. \quad \text{Dividing by 2 on both sides}$$

Thus, $(9, 0)$ is a solution. It is the x -intercept of the graph. We find a third solution as a check. If x is replaced with 3, then

$$2 \cdot 3 + 3y = 18$$

$$6 + 3y = 18$$

$$3y = 12 \quad \text{Subtracting 6 on both sides}$$

$$y = 4. \quad \text{Dividing by 3 on both sides}$$

Thus, $(3, 4)$ is a solution.

We list the solutions in a table and then plot the points. Note that the points appear to lie on a straight line.

Suggestions for Drawing Graphs

1. Calculate solutions and list the ordered pairs in a table.
2. Use graph paper.
3. Draw axes and label them with the variables.
4. Use arrows on the axes to indicate positive directions.
5. Scale the axes; that is, label the tick marks on the axes. Consider the ordered pairs found in part (1) above when choosing the scale.
6. Plot the ordered pairs, look for patterns, and complete the graph. Label the graph with the equation being graphed.

x	y	(x, y)
0	6	$(0, 6)$
9	0	$(9, 0)$
3	4	$(3, 4)$

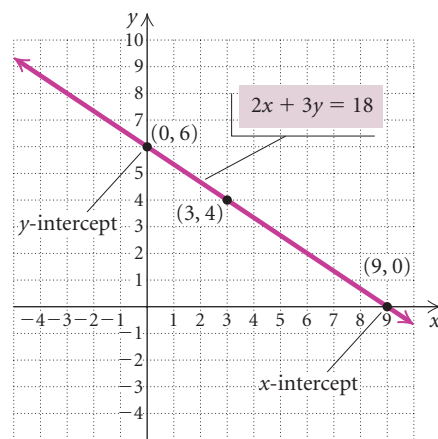

Were we to graph additional solutions of $2x + 3y = 18$, they would be on the same straight line. Thus, to complete the graph, we use a straight-edge to draw a line, as shown in the figure. This line represents all solutions of the equation. Every point on the line represents a solution; every solution is represented by a point on the line.

Now Try Exercise 17.

When graphing some equations, it is convenient to first solve for y and then find ordered pairs. We can use the addition and multiplication principles to solve for y .

EQUATION SOLVING

REVIEW SECTION R.5

EXAMPLE 4 Graph: $3x - 5y = -10$.

Solution We first solve for y :

$$3x - 5y = -10$$

$$-5y = -3x - 10$$

$$y = \frac{3}{5}x + 2.$$

Subtracting $3x$ on both sides

Multiplying by $-\frac{1}{5}$ on both sides

By choosing multiples of 5 for x , we can avoid fraction values when calculating y . For example, if we choose -5 for x , we get

$$y = \frac{3}{5}x + 2 = \frac{3}{5}(-5) + 2 = -3 + 2 = -1.$$

The following table lists a few more points. We plot the points and draw the graph.

x	y	(x, y)
-5	-1	$(-5, -1)$
0	2	$(0, 2)$
5	5	$(5, 5)$

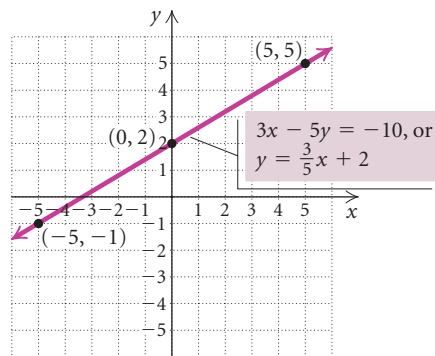

Now Try Exercise 29.

In the equation $y = \frac{3}{5}x + 2$ in Example 4, the value of y depends on the value chosen for x , so x is said to be the **independent variable** and y the **dependent variable**.

TECHNOLOGY CONNECTION

```
Plot1 Plot2 Plot3
Y1=(3/5)X+2
Y2=
Y3=
Y4=
Y5=
Y6=
Y7=
```

```
WINDOW
Xmin = -10
Xmax = 10
Xscl = 1
Ymin = -10
Ymax = 10
Yscl = 1
Xres = 1
```

We can graph an equation on a graphing calculator. Many calculators require an equation to be entered in the form “ $y =$.” In such a case, if the equation is not initially given in this form, it must be solved for y before it is entered in the calculator. For the equation $3x - 5y = -10$ in Example 4, we enter $y = \frac{3}{5}x + 2$ on the equation-editor, or $y =$, screen in the form $y = (3/5)x + 2$, as shown in the window at left. If your calculator uses MathPrint, the display on the equation-editor screen might look somewhat different than what is shown here.

Next, we determine the portion of the xy -plane that will appear on the calculator’s screen. That portion of the plane is called the **viewing window**.

The notation used in this text to denote a window setting consists of four numbers $[L, R, B, T]$, which represent the **L**eft and **R**ight endpoints of the x -axis and the **B**ottom and **T**op endpoints of the y -axis, respectively. The window with the settings $[-10, 10, -10, 10]$ is the **standard viewing window**. On some graphing calculators, the standard window can be selected quickly using the ZSTANDARD feature from the ZOOM menu.

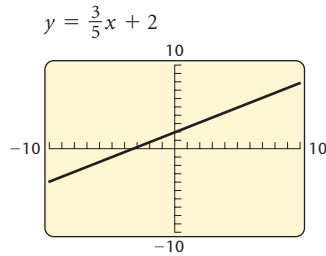

Xmin and Xmax are used to set the left and right endpoints of the x -axis, respectively; Ymin and Ymax are used to set the bottom and top endpoints of the y -axis, respectively. The settings Xscl and Yscl give the scales for the axes. For example, Xscl = 1 and Yscl = 1 means that there is 1 unit between tick marks on each of the axes. In this text, scaling factors other than 1 will be listed by the window unless they are readily apparent.

After entering the equation $y = (3/5)x + 2$ and choosing a viewing window, we can then draw the graph shown at left.

TECHNOLOGY CONNECTION

A graphing calculator can be used to create a table of ordered pairs that are solutions of an equation. For the equation in Example 5, $y = x^2 - 9x - 12$, we first enter the equation on the equation-editor screen. Then we set up a table in AUTO mode by designating a value for TBLSTART and a value for Δ TBL. The calculator will produce a table starting with the value of TBLSTART and continuing by adding Δ TBL to supply succeeding x -values. For the equation $y = x^2 - 9x - 12$, we let TBLSTART = -3 and Δ TBL = 1. We can scroll up and down in the table to find values other than those shown here.

TABLE SETUP
TblStart = -3
 Δ Tbl = 1
Indpnt: Auto Ask
Depend: Auto Ask

X	Y1
-3	24
-2	10
-1	-2
0	-12
1	-20
2	-26
3	-30

X = -3

EXAMPLE 5 Graph: $y = x^2 - 9x - 12$.

Solution Note that since this equation is not of the form $Ax + By = C$, its graph is not a straight line. We make a table of values, plot enough points to obtain an idea of the shape of the curve, and connect them with a smooth curve. It is important to scale the axes to include most of the ordered pairs listed in the table. Here it is appropriate to use a larger scale on the y -axis than on the x -axis.

x	y	(x, y)
-3	24	(-3, 24)
-1	-2	(-1, -2)
0	-12	(0, -12)
2	-26	(2, -26)
4	-32	(4, -32)
5	-32	(5, -32)
10	-2	(10, -2)
12	24	(12, 24)

- ① Select values for x .
② Compute values for y .

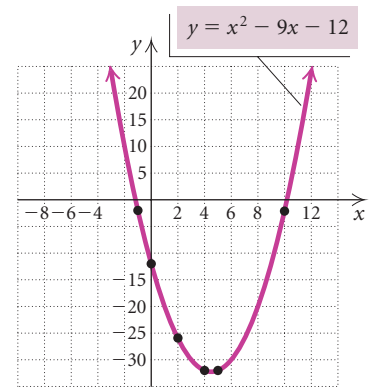

➔ Now Try Exercise 39.

► The Distance Formula

Suppose that a photographer assigned to a story on the Panama Canal needs to determine the distance between two points, A and B , on opposite sides of the canal. One way in which he or she might proceed is to measure two legs of a right triangle that is situated as shown on the following page. The Pythagorean equation, $a^2 + b^2 = c^2$, where c is the length of the hypotenuse

and a and b are the lengths of the legs, can then be used to find the length of the hypotenuse, which is the distance from A to B .

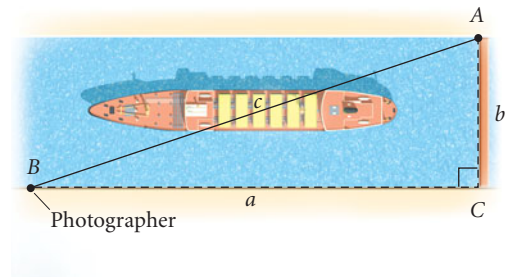

A similar strategy is used to find the distance between two points in a plane. For two points (x_1, y_1) and (x_2, y_2) , we can draw a right triangle in which the legs have lengths $|x_2 - x_1|$ and $|y_2 - y_1|$.

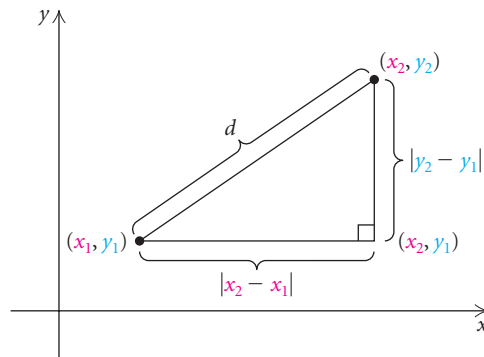

Using the Pythagorean equation, we have

$$d^2 = |x_2 - x_1|^2 + |y_2 - y_1|^2.$$

Substituting d for c , $|x_2 - x_1|$ for a , and $|y_2 - y_1|$ for b in the Pythagorean equation,
 $c^2 = a^2 + b^2$

Because we are squaring, parentheses can replace the absolute-value symbols:

$$d^2 = (x_2 - x_1)^2 + (y_2 - y_1)^2.$$

Taking the principal square root, we obtain the distance formula.

The Distance Formula

The **distance** d between any two points (x_1, y_1) and (x_2, y_2) is given by

$$d = \sqrt{(x_2 - x_1)^2 + (y_2 - y_1)^2}.$$

The subtraction of the x -coordinates can be done in any order, as can the subtraction of the y -coordinates. Although we derived the distance formula by considering two points not on a horizontal line or a vertical line, the distance formula holds for *any* two points.

EXAMPLE 6 Find the distance between each pair of points.

a) $(-2, 2)$ and $(3, -6)$

b) $(-1, -5)$ and $(-1, 2)$

Solution We substitute into the distance formula.

$$\begin{aligned} \text{a) } d &= \sqrt{(x_2 - x_1)^2 + (y_2 - y_1)^2} \\ &= \sqrt{[3 - (-2)]^2 + (-6 - 2)^2} \\ &= \sqrt{5^2 + (-8)^2} = \sqrt{25 + 64} \\ &= \sqrt{89} \approx 9.4 \end{aligned}$$

$$\begin{aligned} \text{b) } d &= \sqrt{(x_2 - x_1)^2 + (y_2 - y_1)^2} \\ &= \sqrt{[-1 - (-1)]^2 + (-5 - 2)^2} \\ &= \sqrt{0^2 + (-7)^2} = \sqrt{0 + 49} \\ &= \sqrt{49} = 7 \end{aligned}$$

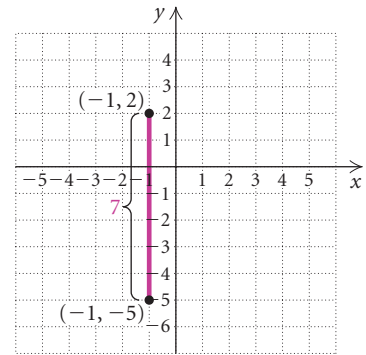
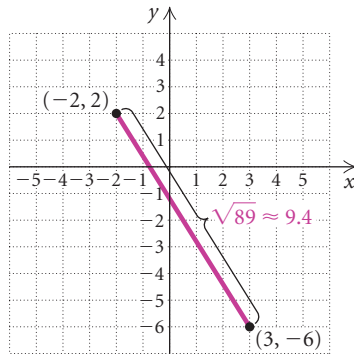

➔ Now Try Exercises 41 and 49.

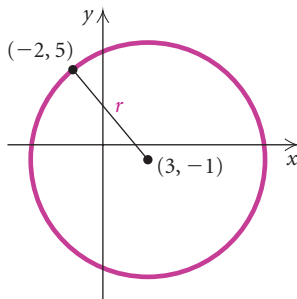

EXAMPLE 7 The point $(-2, 5)$ is on a circle that has $(3, -1)$ as its center. Find the length of the radius of the circle.

Solution Since the length of the radius is the distance from the center to a point on the circle, we substitute into the distance formula:

$$\begin{aligned} d &= \sqrt{(x_2 - x_1)^2 + (y_2 - y_1)^2} \\ r &= \sqrt{[3 - (-2)]^2 + (-1 - 5)^2} \\ &= \sqrt{5^2 + (-6)^2} = \sqrt{25 + 36} \\ &= \sqrt{61} \approx 7.8. \end{aligned}$$

Substituting r for d , $(3, -1)$ for (x_2, y_2) , and $(-2, 5)$ for (x_1, y_1) . Either point can serve as (x_1, y_1) .

Rounded to the nearest tenth

The radius of the circle is approximately 7.8.

➔ Now Try Exercise 55.

► Midpoints of Segments

The distance formula can be used to develop a method of determining the *midpoint* of a segment when the endpoints are known. We state the formula and leave its proof to the exercises.

The Midpoint Formula

If the endpoints of a segment are (x_1, y_1) and (x_2, y_2) , then the coordinates of the **midpoint** of the segment are

$$\left(\frac{x_1 + x_2}{2}, \frac{y_1 + y_2}{2} \right).$$

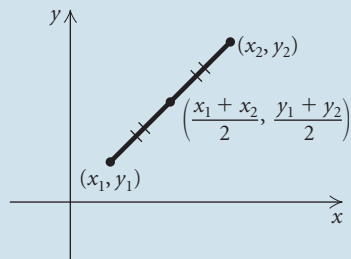

Note that we obtain the coordinates of the midpoint by averaging the coordinates of the endpoints. This is a good way to remember the midpoint formula.

EXAMPLE 8 Find the midpoint of the segment whose endpoints are $(-4, -2)$ and $(2, 5)$.

Solution Using the midpoint formula, we obtain

$$\left(\frac{-4 + 2}{2}, \frac{-2 + 5}{2} \right) = \left(\frac{-2}{2}, \frac{3}{2} \right) = \left(-1, \frac{3}{2} \right).$$

➔ Now Try Exercise 61.

EXAMPLE 9 The diameter of a circle connects the points $(2, -3)$ and $(6, 4)$ on the circle. Find the coordinates of the center of the circle.

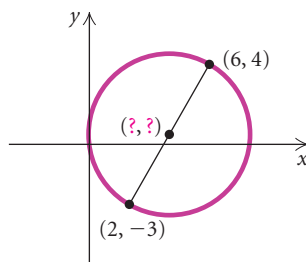

Solution Since the center of the circle is the midpoint of the diameter, we use the midpoint formula:

$$\left(\frac{2 + 6}{2}, \frac{-3 + 4}{2} \right), \text{ or } \left(\frac{8}{2}, \frac{1}{2} \right), \text{ or } \left(4, \frac{1}{2} \right).$$

The coordinates of the center are $\left(4, \frac{1}{2} \right)$.

➔ Now Try Exercise 73.

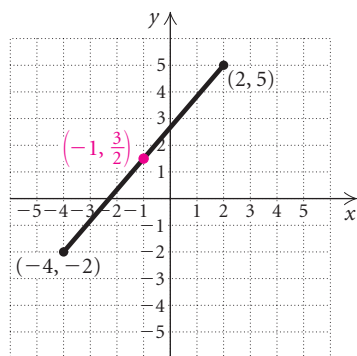

► Circles

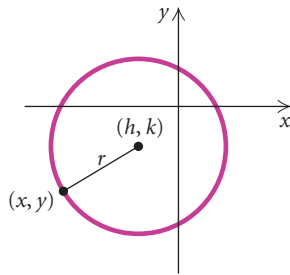

A **circle** is the set of all points in a plane that are a fixed distance r from a **center** (h, k) . Thus if a point (x, y) is to be r units from the center, we must have

$$r = \sqrt{(x - h)^2 + (y - k)^2}.$$

Using the distance formula,

$$d = \sqrt{(x_2 - x_1)^2 + (y_2 - y_1)^2}$$

Squaring both sides gives an equation of a circle. The distance r is the length of a *radius* of the circle.

The Equation of a Circle

The standard form of the equation of a circle with center (h, k) and radius r is

$$(x - h)^2 + (y - k)^2 = r^2.$$

EXAMPLE 10 Find an equation of the circle having radius 5 and center $(3, -7)$.

Solution Using the standard form, we have

$$[x - 3]^2 + [y - (-7)]^2 = 5^2 \quad \text{Substituting}$$

$$(x - 3)^2 + (y + 7)^2 = 25.$$

➔ Now Try Exercise 75.

EXAMPLE 11 Graph the circle $(x + 5)^2 + (y - 2)^2 = 16$.

Solution We write the equation in standard form to determine the center and the radius:

$$[x - (-5)]^2 + [y - 2]^2 = 4^2.$$

The center is $(-5, 2)$ and the radius is 4. We locate the center and draw the circle using a compass.

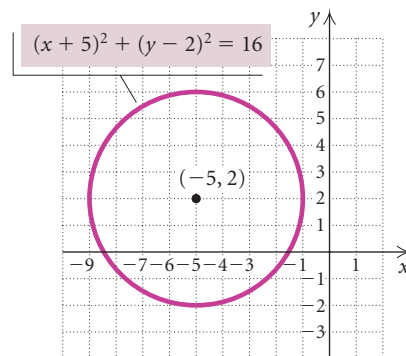

➔ Now Try Exercise 87.

TECHNOLOGY CONNECTION

When we graph a circle, we select a viewing window in which the distance between units is visually the same on both axes. This procedure is called **squaring the viewing window**. We do this so that the graph will not be distorted. A graph of the circle $x^2 + y^2 = 36$ in a nonsquared window is shown in Fig. 1.

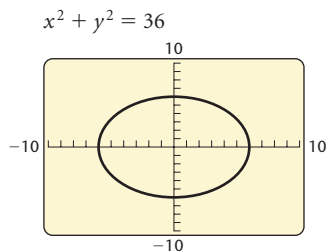

Figure 1

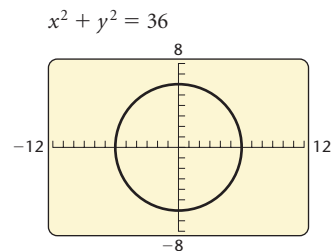
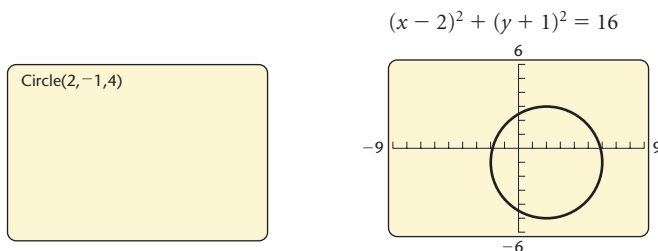
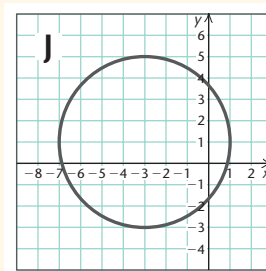
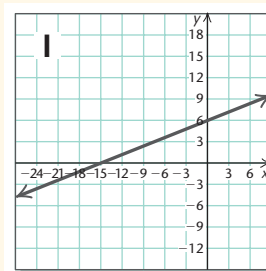
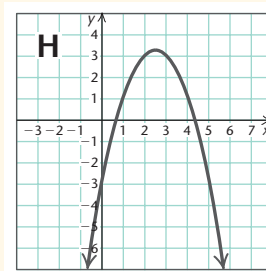
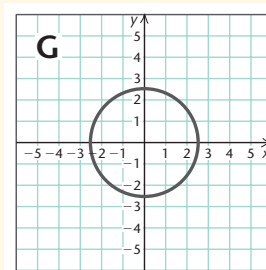
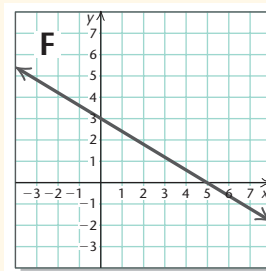
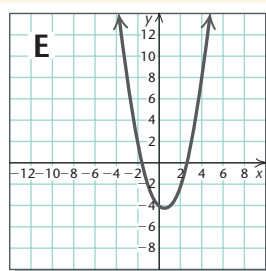
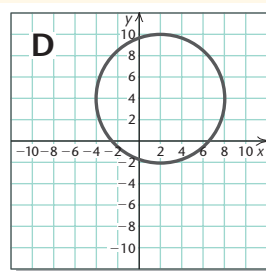
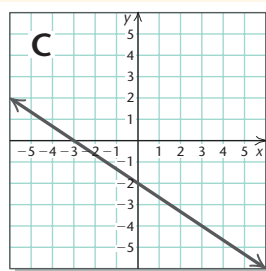
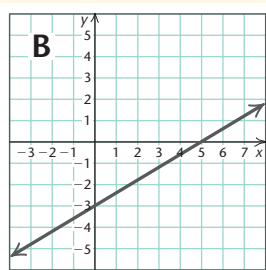
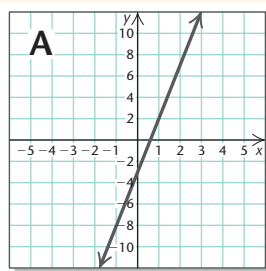

Figure 2

On many graphing calculators, the ratio of the height to the width of the viewing screen is $\frac{2}{3}$. When we choose a window in which $X_{\text{scl}} = Y_{\text{scl}}$ and the length of the y -axis is $\frac{2}{3}$ the length of the x -axis, the window will be squared. The windows with dimensions $[-6, 6, -4, 4]$, $[-9, 9, -6, 6]$, and $[-12, 12, -8, 8]$ are examples of squared windows. A graph of the circle $x^2 + y^2 = 36$ in a squared window is shown in Fig. 2. Many graphing calculators have an option on the ZOOM menu that squares the window automatically.

To graph a circle, we select the CIRCLE feature from the DRAW menu and enter the coordinates of the center and the length of the radius. The graph of the circle $(x - 2)^2 + (y + 1)^2 = 16$ is shown here. For more on graphing circles with a graphing calculator, see Section 7.2.





Visualizing the Graph

Match the equation with its graph.

- $y = -x^2 + 5x - 3$
- $3x - 5y = 15$
- $(x - 2)^2 + (y - 4)^2 = 36$
- $y - 5x = -3$
- $x^2 + y^2 = \frac{25}{4}$
- $15y - 6x = 90$
- $y = -\frac{2}{3}x - 2$
- $(x + 3)^2 + (y - 1)^2 = 16$
- $3x + 5y = 15$
- $y = x^2 - x - 4$

Answers on page A-3

1.1

Exercise Set

Use this graph for Exercises 1 and 2.

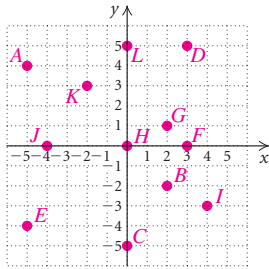

- Find the coordinates of points A, B, C, D, E, and F.
- Find the coordinates of points G, H, I, J, K, and L.

Graph and label the given points.

- $(4, 0)$, $(-3, -5)$, $(-1, 4)$, $(0, 2)$, $(2, -2)$
- $(1, 4)$, $(-4, -2)$, $(-5, 0)$, $(2, -4)$, $(4, 0)$
- $(-5, 1)$, $(5, 1)$, $(2, 3)$, $(2, -1)$, $(0, 1)$
- $(4, 0)$, $(4, -3)$, $(-5, 2)$, $(-5, 0)$, $(-1, -5)$

Express the data pictured in the graph as ordered pairs, letting the first coordinate represent the year and the second coordinate the amount or percent.

7. Percentage of U.S. Population That Is Foreign-Born

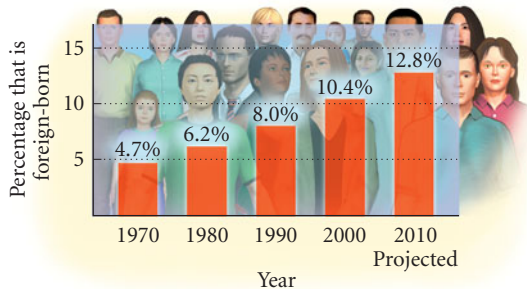

Sources: U.S. Census Bureau; U.S. Department of Commerce

8. NASCAR — Jeff Gordon in the Top 5

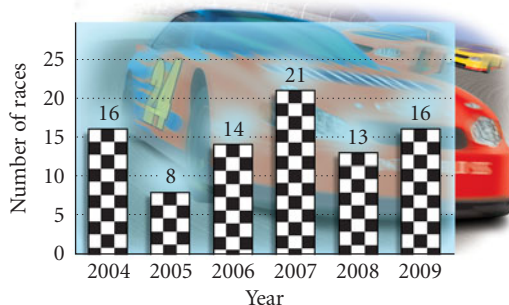

Source: Racing-Reference.info

Use substitution to determine whether the given ordered pairs are solutions of the given equation.

- $(-1, -9)$, $(0, 2)$; $y = 7x - 2$
- $(\frac{1}{2}, 8)$, $(-1, 6)$; $y = -4x + 10$
- $(\frac{2}{3}, \frac{3}{4})$, $(1, \frac{3}{2})$; $6x - 4y = 1$
- $(1.5, 2.6)$, $(-3, 0)$; $x^2 + y^2 = 9$
- $(-\frac{1}{2}, -\frac{4}{5})$, $(0, \frac{3}{5})$; $2a + 5b = 3$
- $(0, \frac{3}{2})$, $(\frac{2}{3}, 1)$; $3m + 4n = 6$
- $(-0.75, 2.75)$, $(2, -1)$; $x^2 - y^2 = 3$
- $(2, -4)$, $(4, -5)$; $5x + 2y^2 = 70$

Find the intercepts and then graph the line.

- $5x - 3y = -15$
- $2x - 4y = 8$
- $2x + y = 4$
- $3x + y = 6$
- $4y - 3x = 12$
- $3y + 2x = -6$

Graph the equation.

- $y = 3x + 5$
- $y = -2x - 1$
- $x - y = 3$
- $x + y = 4$
- $y = -\frac{3}{4}x + 3$
- $3y - 2x = 3$
- $5x - 2y = 8$
- $y = 2 - \frac{4}{3}x$
- $x - 4y = 5$
- $6x - y = 4$
- $2x + 5y = -10$
- $4x - 3y = 12$
- $y = -x^2$
- $y = x^2$
- $y = x^2 - 3$
- $y = 4 - x^2$
- $y = -x^2 + 2x + 3$
- $y = x^2 + 2x - 1$

Find the distance between the pair of points. Give an exact answer and, where appropriate, an approximation to three decimal places.

- $(4, 6)$ and $(5, 9)$
- $(-3, 7)$ and $(2, 11)$
- $(-11, -8)$ and $(1, -13)$
- $(-60, 5)$ and $(-20, 35)$
- $(6, -1)$ and $(9, 5)$
- $(-4, -7)$ and $(-1, 3)$

47. $(-8, \frac{7}{11})$ and $(8, \frac{7}{11})$
48. $(\frac{1}{2}, -\frac{4}{25})$ and $(\frac{1}{2}, -\frac{13}{25})$
49. $(-\frac{3}{5}, -4)$ and $(-\frac{3}{5}, \frac{2}{3})$
50. $(-\frac{11}{3}, -\frac{1}{2})$ and $(\frac{1}{3}, \frac{5}{2})$
51. $(-4.2, 3)$ and $(2.1, -6.4)$
52. $(0.6, -1.5)$ and $(-8.1, -1.5)$
53. $(0, 0)$ and (a, b)
54. (r, s) and $(-r, -s)$
55. The points $(-3, -1)$ and $(9, 4)$ are the endpoints of the diameter of a circle. Find the length of the radius of the circle.
56. The point $(0, 1)$ is on a circle that has center $(-3, 5)$. Find the length of the diameter of the circle.
69. $(-\frac{1}{6}, -\frac{3}{5})$ and $(-\frac{2}{3}, \frac{5}{4})$
70. $(\frac{2}{9}, \frac{1}{3})$ and $(-\frac{2}{5}, \frac{4}{5})$
71. Graph the rectangle described in Exercise 60. Then determine the coordinates of the midpoint of each of the four sides. Are the midpoints vertices of a rectangle?
72. Graph the square with vertices $(-5, -1)$, $(7, -6)$, $(12, 6)$, and $(0, 11)$. Then determine the midpoint of each of the four sides. Are the midpoints vertices of a square?
73. The points $(\sqrt{7}, -4)$ and $(\sqrt{2}, 3)$ are endpoints of the diameter of a circle. Determine the center of the circle.
74. The points $(-3, \sqrt{5})$ and $(1, \sqrt{2})$ are endpoints of the diagonal of a square. Determine the center of the square.

The converse of the Pythagorean theorem is also a true statement: If the sum of the squares of the lengths of two sides of a triangle is equal to the square of the length of the third side, then the triangle is a right triangle. Use the distance formula and the Pythagorean theorem to determine whether the set of points could be vertices of a right triangle.

57. $(-4, 5)$, $(6, 1)$, and $(-8, -5)$
58. $(-3, 1)$, $(2, -1)$, and $(6, 9)$
59. $(-4, 3)$, $(0, 5)$, and $(3, -4)$
60. The points $(-3, 4)$, $(2, -1)$, $(5, 2)$, and $(0, 7)$ are vertices of a quadrilateral. Show that the quadrilateral is a rectangle. (*Hint:* Show that the quadrilateral's opposite sides are the same length and that the two diagonals are the same length.)

Find the midpoint of the segment having the given endpoints.

61. $(4, -9)$ and $(-12, -3)$
62. $(7, -2)$ and $(9, 5)$
63. $(0, \frac{1}{2})$ and $(-\frac{2}{5}, 0)$
64. $(0, 0)$ and $(-\frac{7}{13}, \frac{2}{7})$
65. $(6.1, -3.8)$ and $(3.8, -6.1)$
66. $(-0.5, -2.7)$ and $(4.8, -0.3)$
67. $(-6, 5)$ and $(-6, 8)$
68. $(1, -2)$ and $(-1, 2)$

Find an equation for a circle satisfying the given conditions.

75. Center $(2, 3)$, radius of length $\frac{5}{3}$
76. Center $(4, 5)$, diameter of length 8.2
77. Center $(-1, 4)$, passes through $(3, 7)$
78. Center $(6, -5)$, passes through $(1, 7)$
79. The points $(7, 13)$ and $(-3, -11)$ are at the ends of a diameter.
80. The points $(-9, 4)$, $(-2, 5)$, $(-8, -3)$, and $(-1, -2)$ are vertices of an inscribed square.
81. Center $(-2, 3)$, tangent (touching at one point) to the y -axis

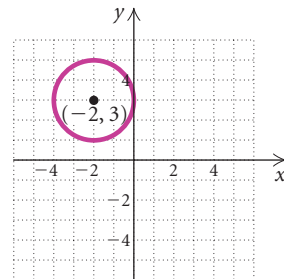

82. Center $(4, -5)$, tangent to the x -axis

Find the center and the radius of the circle. Then graph the circle.

83. $x^2 + y^2 = 4$
84. $x^2 + y^2 = 81$

85. $x^2 + (y - 3)^2 = 16$
 86. $(x + 2)^2 + y^2 = 100$
 87. $(x - 1)^2 + (y - 5)^2 = 36$
 88. $(x - 7)^2 + (y + 2)^2 = 25$
 89. $(x + 4)^2 + (y + 5)^2 = 9$
 90. $(x + 1)^2 + (y - 2)^2 = 64$

Find the equation of the circle. Express the equation in standard form.

91.

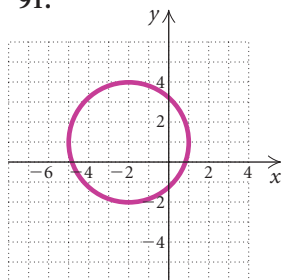

92.

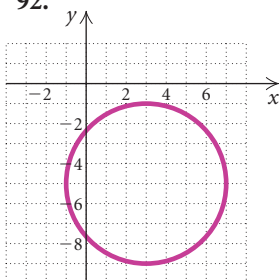

93.

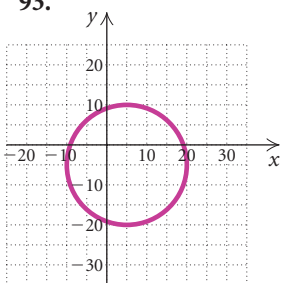

94.

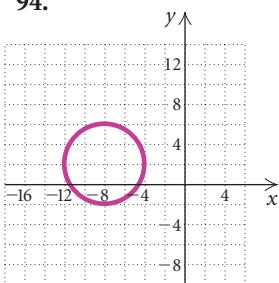

Find an equation of a circle satisfying the given conditions.

98. Center $(-5, 8)$ with a circumference of 10π units
 99. Center $(2, -7)$ with an area of 36π square units
 100. Find the point on the x -axis that is equidistant from the points $(-4, -3)$ and $(-1, 5)$.
 101. Find the point on the y -axis that is equidistant from the points $(-2, 0)$ and $(4, 6)$.
 102. Determine whether the points $(-1, -3)$, $(-4, -9)$, and $(2, 3)$ are collinear.
 103. **An Arch of a Circle in Carpentry.** Matt is remodeling the front entrance to his home and needs to cut an arch for the top of an entranceway. The arch needs to be 8 ft wide and 2 ft high. To draw the arch, he will use a stretched string with chalk attached at an end as a compass.

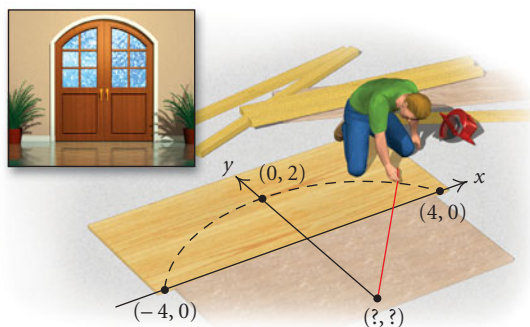

- a) Using a coordinate system, locate the center of the circle.
 b) What radius should Matt use to draw the arch?

104. Consider any right triangle with base b and height h , situated as shown. Show that the midpoint of the hypotenuse P is equidistant from the three vertices of the triangle.

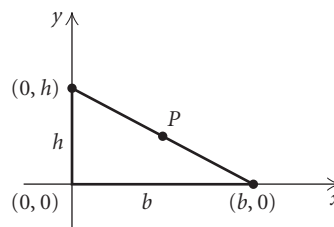

Synthesis

To the student and the instructor: The Synthesis exercises found at the end of every exercise set challenge students to combine concepts or skills studied in that section or in preceding parts of the text.

95. If the point (p, q) is in the fourth quadrant, in which quadrant is the point $(q, -p)$?

Find the distance between the pair of points and find the midpoint of the segment having the given points as endpoints.

96. $(a, \frac{1}{a})$ and $(a + h, \frac{1}{a + h})$
 97. (a, \sqrt{a}) and $(a + h, \sqrt{a + h})$

Determine whether each of the following points lies on the **unit circle**, $x^2 + y^2 = 1$.

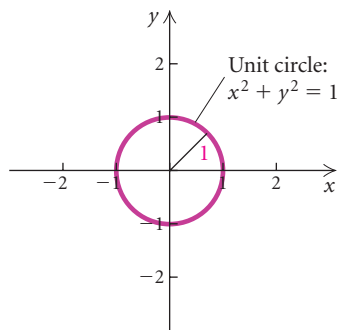

105. $\left(\frac{\sqrt{3}}{2}, -\frac{1}{2}\right)$

106. $(0, -1)$

107. $\left(-\frac{\sqrt{2}}{2}, \frac{\sqrt{2}}{2}\right)$

108. $\left(\frac{1}{2}, -\frac{\sqrt{3}}{2}\right)$

109. Prove the midpoint formula by showing that:

- a) $\left(\frac{x_1 + x_2}{2}, \frac{y_1 + y_2}{2}\right)$ is equidistant from the points (x_1, y_1) and (x_2, y_2) ; and
 b) the distance from (x_1, y_1) to the midpoint plus the distance from (x_2, y_2) to the midpoint equals the distance from (x_1, y_1) to (x_2, y_2) .

Functions and Graphs

1.2

- ▶ Determine whether a correspondence or a relation is a function.
- ▶ Find function values, or outputs, using a formula or a graph.
- ▶ Graph functions.
- ▶ Determine whether a graph is that of a function.
- ▶ Find the domain and the range of a function.
- ▶ Solve applied problems using functions.

We now focus our attention on a concept that is fundamental to many areas of mathematics—the idea of a *function*.

▶ Functions

We first consider an application.

Child's Age Related to Recommended Daily Amount of Fiber. The recommended minimum amount of dietary fiber needed each day for children age 3 and older is the child's age, in years, plus 5 grams of fiber. If a child is



7 years old, the minimum recommendation per day is $7 + 5$, or 12, grams of fiber. Similarly, a 3-year-old needs $3 + 5$, or 8, grams of fiber. (Sources: *American Family Physician*, April 1996; American Health Foundation) We can express this relationship with a set of ordered pairs, a graph, and an equation.

x	y	Ordered Pairs: (x, y)	Correspondence
3	8	$(3, 8)$	$3 \rightarrow 8$
$4\frac{1}{2}$	$9\frac{1}{2}$	$(4\frac{1}{2}, 9\frac{1}{2})$	$4\frac{1}{2} \rightarrow 9\frac{1}{2}$
7	12	$(7, 12)$	$7 \rightarrow 12$
$10\frac{2}{3}$	$15\frac{2}{3}$	$(10\frac{2}{3}, 15\frac{2}{3})$	$10\frac{2}{3} \rightarrow 15\frac{2}{3}$
14	19	$(14, 19)$	$14 \rightarrow 19$

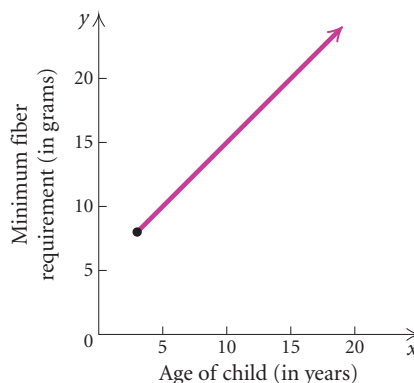

The ordered pairs express a relationship, or correspondence, between the first and second coordinates. We can see this relationship in the graph as well. The equation that describes the correspondence is

$$y = x + 5, x \geq 3.$$

This is an example of a *function*. In this case, grams of fiber y is a function of age x ; that is, y is a function of x , where x is the independent variable and y is the dependent variable.

Let's consider some other correspondences before giving the definition of a function.

First Set	Correspondence	Second Set
To each person	there corresponds	that person's DNA.
To each blue spruce sold	there corresponds	its price.
To each real number	there corresponds	the square of that number.

In each correspondence, the first set is called the **domain** and the second set is called the **range**. For each member, or **element**, in the domain, there is *exactly one* member in the range to which it corresponds. Thus each person has exactly *one* DNA, each blue spruce has exactly *one* price, and each real number has exactly *one* square. Each correspondence is a *function*.

Function

A **function** is a correspondence between a first set, called the **domain**, and a second set, called the **range**, such that each member of the domain corresponds to *exactly one* member of the range.

It is important to note that not every correspondence between two sets is a function.

EXAMPLE 1 Determine whether each of the following correspondences is a function.

a)

$$\begin{array}{l} -6 \rightarrow 36 \\ 6 \rightarrow 36 \\ -3 \rightarrow 9 \\ 3 \rightarrow 9 \\ 0 \rightarrow 0 \end{array}$$

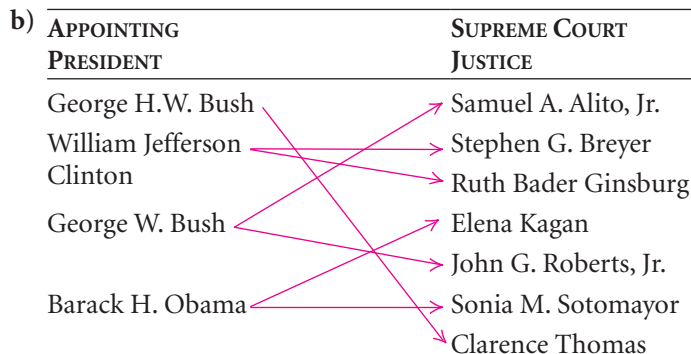

Solution

- a) This correspondence *is* a function because each member of the domain corresponds to exactly one member of the range. Note that the definition of a function allows more than one member of the domain to correspond to the same member of the range.
- b) This correspondence is *not* a function because there is at least one member of the domain who is paired with more than one member of the range (William Jefferson Clinton with Stephen G. Breyer and Ruth Bader Ginsburg; George W. Bush with Samuel A. Alito, Jr., and John G. Roberts, Jr.; Barack H. Obama with Elena Kagan and Sonia M. Sotomayor).



EXAMPLE 2 Determine whether each of the following correspondences is a function.

DOMAIN	CORRESPONDENCE	RANGE
a) Years in which a presidential election occurs	The person elected	A set of presidents
b) All automobiles produced in 2011	Each automobile's VIN	A set of VIN numbers
c) The set of all drivers who won a NASCAR race in 2009	The race won	The set of all NASCAR races in 2009
d) The set of all NASCAR races in 2009	The winner of the race	The set of all drivers who won a NASCAR race in 2009

Solution

- a) This correspondence *is* a function because in each presidential election *exactly one* president is elected.
- b) This correspondence *is* a function because each automobile has *exactly one* VIN number.
- c) This correspondence *is not* a function because a winning driver could be paired with more than one race.
- d) This correspondence *is* a function because each race has only one winning driver.

 **Now Try Exercise 11.**



When a correspondence between two sets is not a function, it may still be an example of a **relation**.

Relation

A **relation** is a correspondence between a first set, called the **domain**, and a second set, called the **range**, such that each member of the domain corresponds to *at least one* member of the range.

All the correspondences in Examples 1 and 2 are relations, but, as we have seen, not all are functions. Relations are sometimes written as sets of ordered pairs (as we saw earlier in the example on dietary fiber) in which elements of the domain are the first coordinates of the ordered pairs and elements of the range are the second coordinates. For example, instead of writing $-3 \rightarrow 9$, as we did in Example 1(a), we could write the ordered pair $(-3, 9)$.

EXAMPLE 3 Determine whether each of the following relations is a function. Identify the domain and the range.

- a) $\{(9, -5), (9, 5), (2, 4)\}$
- b) $\{(-2, 5), (5, 7), (0, 1), (4, -2)\}$
- c) $\{(-5, 3), (0, 3), (6, 3)\}$

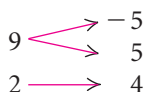

Figure 1

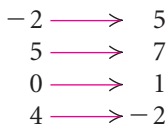

Figure 2

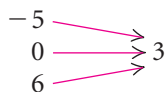

Figure 3

Solution

- a) The relation *is not* a function because the ordered pairs $(9, -5)$ and $(9, 5)$ have the same first coordinate and different second coordinates. (See Fig. 1.)

The domain is the set of all first coordinates: $\{9, 2\}$.

The range is the set of all second coordinates: $\{-5, 5, 4\}$.

- b) The relation *is* a function because *no* two ordered pairs have the same first coordinate and different second coordinates. (See Fig. 2.)

The domain is the set of all first coordinates: $\{-2, 5, 0, 4\}$.

The range is the set of all second coordinates: $\{5, 7, 1, -2\}$.

- c) The relation *is* a function because *no* two ordered pairs have the same first coordinate and different second coordinates. (See Fig. 3.)

The domain is $\{-5, 0, 6\}$.

The range is $\{3\}$.

➡ Now Try Exercises 15 and 17.

► Notation for Functions

Functions used in mathematics are often given by equations. They generally require that certain calculations be performed in order to determine which member of the range is paired with each member of the domain. For example, in Section 1.1 we graphed the function $y = x^2 - 9x - 12$ by doing calculations like the following:

$$\text{for } x = -2, y = (-2)^2 - 9(-2) - 12 = 10,$$

$$\text{for } x = 0, y = 0^2 - 9 \cdot 0 - 12 = -12, \text{ and}$$

$$\text{for } x = 1, y = 1^2 - 9 \cdot 1 - 12 = -20.$$

A more concise notation is often used. For $y = x^2 - 9x - 12$, the **inputs** (members of the domain) are values of x substituted into the equation. The **outputs** (members of the range) are the resulting values of y . If we call the function f , we can use x to represent an arbitrary *input* and $f(x)$ —read “ f of x ,” or “ f at x ,” or “the value of f at x ”—to represent the corresponding *output*. In this notation, the function given by $y = x^2 - 9x - 12$ is written as $f(x) = x^2 - 9x - 12$ and the above calculations would be

$$f(-2) = (-2)^2 - 9(-2) - 12 = 10,$$

$$f(0) = 0^2 - 9 \cdot 0 - 12 = -12,$$

$$f(1) = 1^2 - 9 \cdot 1 - 12 = -20.$$

Keep in mind that $f(x)$ does not mean $f \cdot x$.

Thus, instead of writing “when $x = -2$, the value of y is 10,” we can simply write “ $f(-2) = 10$,” which can be read as “ f of -2 is 10” or “for the input -2 , the output of f is 10.” The letters g and h are also often used to name functions.

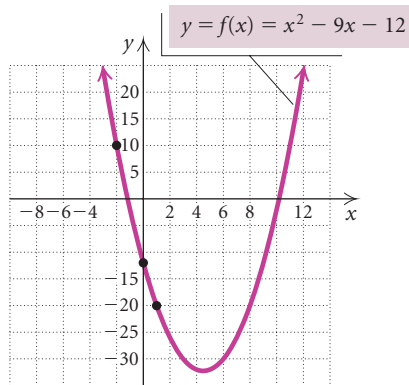

TECHNOLOGY CONNECTION

We can find function values with a graphing calculator. Below, we illustrate finding $f(-7)$ from Example 4(b), first with the TABLE feature set in ASK mode and then with the VALUE feature from the CALC menu. In both screens, we see that $f(-7) = 108$.

X	Y1
-7	108

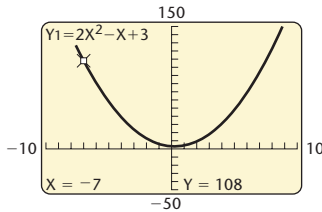

EXAMPLE 4 A function f is given by $f(x) = 2x^2 - x + 3$. Find each of the following.

- a) $f(0)$ b) $f(-7)$
 c) $f(5a)$ d) $f(a - 4)$

Solution We can think of this formula as follows:

$$f(\square) = 2(\square)^2 - (\square) + 3.$$

Then to find an output for a given input, we think: “Whatever goes in the blank on the left goes in the blank(s) on the right.” This gives us a “recipe” for finding outputs.

a) $f(0) = 2(0)^2 - 0 + 3 = 0 - 0 + 3 = 3$

b) $f(-7) = 2(-7)^2 - (-7) + 3 = 2 \cdot 49 + 7 + 3 = 108$

c) $f(5a) = 2(5a)^2 - 5a + 3 = 2 \cdot 25a^2 - 5a + 3 = 50a^2 - 5a + 3$

d) $f(a - 4) = 2(a - 4)^2 - (a - 4) + 3$
 $= 2(a^2 - 8a + 16) - (a - 4) + 3$
 $= 2a^2 - 16a + 32 - a + 4 + 3$
 $= 2a^2 - 17a + 39$

Now Try Exercise 21.

▶ Graphs of Functions

We graph functions the same way we graph equations. We find ordered pairs (x, y) , or $(x, f(x))$, plot points, and complete the graph.

EXAMPLE 5 Graph each of the following functions.

- a) $f(x) = x^2 - 5$
 b) $f(x) = x^3 - x$
 c) $f(x) = \sqrt{x + 4}$

Solution We select values for x and find the corresponding values of $f(x)$. Then we plot the points and connect them with a smooth curve.

a) $f(x) = x^2 - 5$

x	$f(x)$	$(x, f(x))$
-3	4	$(-3, 4)$
-2	-1	$(-2, -1)$
-1	-4	$(-1, -4)$
0	-5	$(0, -5)$
1	-4	$(1, -4)$
2	-1	$(2, -1)$
3	4	$(3, 4)$

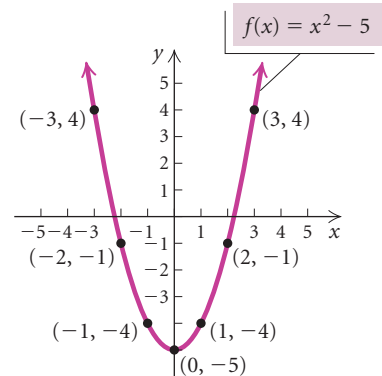

b) $f(x) = x^3 - x$

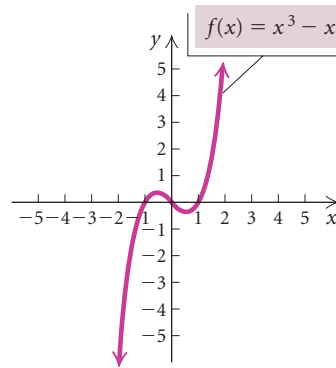

c) $f(x) = \sqrt{x + 4}$

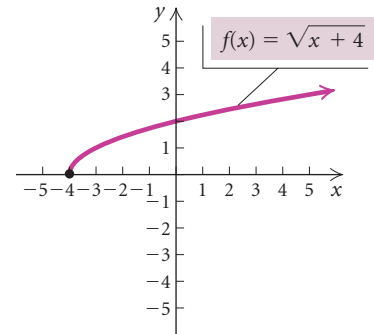

Now Try Exercise 31.

Function values can be also determined from a graph.

EXAMPLE 6 For the function $f(x) = x^2 - 6$, use the graph to find each of the following function values.

a) $f(-3)$

b) $f(1)$

Solution

a) To find the function value $f(-3)$ from the graph at left, we locate the input -3 on the horizontal axis, move vertically to the graph of the function, and then move horizontally to find the output on the vertical axis. We see that $f(-3) = 3$.

b) To find the function value $f(1)$, we locate the input 1 on the horizontal axis, move vertically to the graph, and then move horizontally to find the output on the vertical axis. We see that $f(1) = -5$.

Now Try Exercise 35.

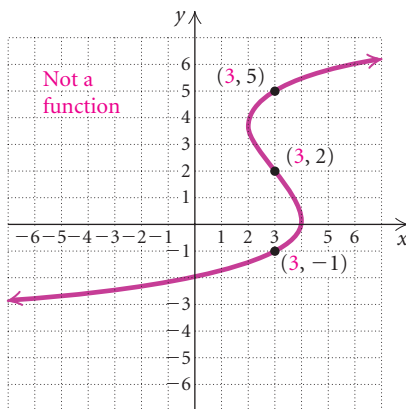
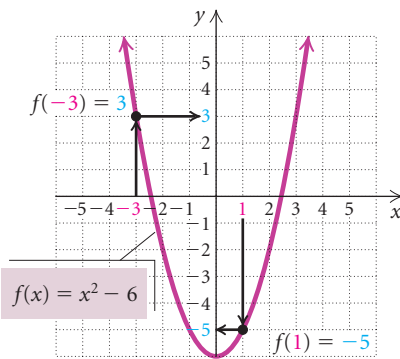

Since 3 is paired with more than one member of the range, the graph does not represent a function.

We know that when one member of the domain is paired with two or more different members of the range, the correspondence *is not* a function. Thus, when a graph contains two or more different points with the same first coordinate, the graph cannot represent a function. (See the graph at left. Note that 3 is paired with -1 , 2 , and 5 .) Points sharing a common first coordinate are vertically above or below each other. This leads us to the *vertical-line test*.

The Vertical-Line Test

If it is possible for a vertical line to cross a graph more than once, then the graph *is not* the graph of a function.

To apply the vertical-line test, we try to find a vertical line that crosses the graph more than once. If we succeed, then the graph is not that of a function. If we do not, then the graph is that of a function.

EXAMPLE 7 Which of graphs (a)–(f) (in red) are graphs of functions? In graph (f), the solid dot shows that $(-1, 1)$ belongs to the graph. The open circle shows that $(-1, -2)$ does *not* belong to the graph.

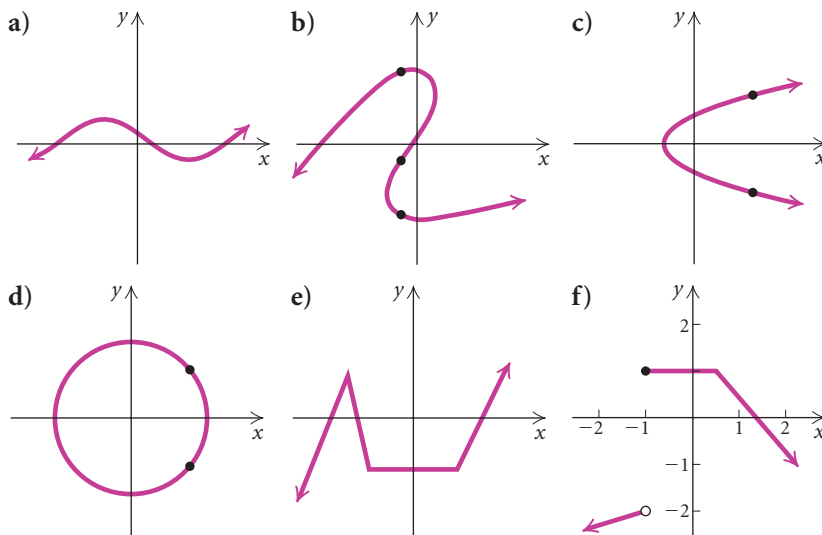

Solution Graphs (a), (e), and (f) are graphs of functions because we cannot find a vertical line that crosses any of them more than once. In (b), the vertical line drawn crosses the graph at three points, so graph (b) is not that of a function. Also, in (c) and (d), we can find a vertical line that crosses the graph more than once, so these are not graphs of functions.

➔ Now Try Exercises 43 and 47.

REAL NUMBERS

REVIEW SECTION R.1

► Finding Domains of Functions

When a function f whose inputs and outputs are real numbers is given by a formula, the *domain* is understood to be the set of all inputs for which the expression is defined as a real number. When an input results in an expression that is not defined as a real number, we say that the function value *does not exist* and that the number being substituted is *not* in the domain of the function.

EXAMPLE 8 Find the indicated function values, if possible, and determine whether the given values are in the domain of the function.

- a) $f(1)$ and $f(3)$, for $f(x) = \frac{1}{x-3}$
 b) $g(16)$ and $g(-7)$, for $g(x) = \sqrt{x} + 5$

Solution

$$\text{a) } f(1) = \frac{1}{1-3} = \frac{1}{-2} = -\frac{1}{2}$$

Since $f(1)$ is defined, 1 is in the domain of f .

TECHNOLOGY CONNECTION

When we use a graphing calculator to find function values and a function value does not exist, the calculator indicates this with an ERROR message.

In the tables below, we see in Example 8 that $f(3)$ for $f(x) = 1/(x - 3)$ and $g(-7)$ for $g(x) = \sqrt{x} + 5$ do not exist. Thus, 3 and -7 are *not* in the domains of the corresponding functions.

$$y = \frac{1}{x - 3}$$

X	Y1	
1	-5	
3	ERROR	
X =		

$$y = \sqrt{x} + 5$$

X	Y1	
16	9	
-7	ERROR	
X =		

INTERVAL NOTATION

REVIEW SECTION R.1

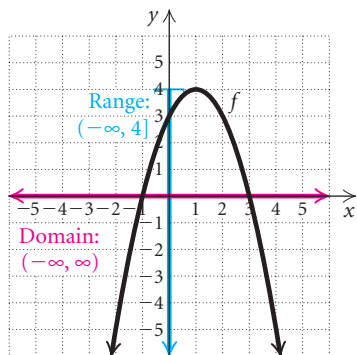

$$f(3) = \frac{1}{3 - 3} = \frac{1}{0}$$

Since division by 0 is not defined, $f(3)$ does not exist and the number 3 is not in the domain of f .

$$\text{b) } g(16) = \sqrt{16} + 5 = 4 + 5 = 9$$

Since $g(16)$ is defined, 16 is in the domain of g .

$$g(-7) = \sqrt{-7} + 5$$

Since $\sqrt{-7}$ is not defined as a real number, $g(-7)$ does not exist and the number -7 is not in the domain of g . ←

As we see in Example 8, inputs that make a denominator 0 or that yield a negative radicand in an even root are not in the domain of a function.

EXAMPLE 9 Find the domain of each of the following functions.

$$\text{a) } f(x) = \frac{1}{x - 7} \quad \text{b) } h(x) = \frac{3x^2 - x + 7}{x^2 + 2x - 3} \quad \text{c) } f(x) = x^3 + |x|$$

Solution

- a) Because $x - 7 = 0$ when $x = 7$, the only input that results in a denominator of 0 is 7. The domain is $\{x \mid x \neq 7\}$. We can also write the solution using interval notation and the symbol \cup for the **union**, or inclusion, of both sets: $(-\infty, 7) \cup (7, \infty)$.
- b) We can substitute any real number in the numerator, but we must avoid inputs that make the denominator 0. To find those inputs, we solve $x^2 + 2x - 3 = 0$, or $(x + 3)(x - 1) = 0$. Since $x^2 + 2x - 3$ is 0 for -3 and 1, the domain consists of the set of all real numbers except -3 and 1, or $\{x \mid x \neq -3 \text{ and } x \neq 1\}$, or $(-\infty, -3) \cup (-3, 1) \cup (1, \infty)$.
- c) We can substitute any real number for x . Thus the domain is the set of all real numbers, \mathbb{R} , or $(-\infty, \infty)$. → **Now Try Exercises 55, 57, and 61.**

► Visualizing Domain and Range

Keep the following in mind regarding the *graph* of a function:

Domain = the set of a function's inputs, found on the horizontal axis (x -axis);

Range = the set of a function's outputs, found on the vertical axis (y -axis).

Consider the graph of function f , shown at left. To determine the domain of f , we look for the inputs on the x -axis that correspond to a point on the graph. We see that they include the entire set of real numbers, illustrated in red on the x -axis. Thus the **domain** is $(-\infty, \infty)$. To find the range, we look for the outputs on the y -axis that correspond to a point on

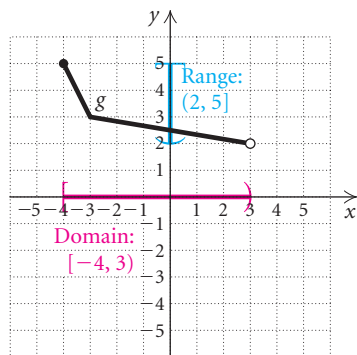

the graph. We see that they include 4 and all real numbers less than 4, illustrated in blue on the y -axis. The bracket at 4 indicates that 4 is included in the interval. The **range** is $\{y \mid y \leq 4\}$, or $(-\infty, 4]$.

Let's now consider the graph of function g , shown at left. The solid dot shows that $(-4, 5)$ belongs to the graph. The open circle shows that $(3, 2)$ does *not* belong to the graph.

We see that the inputs of the function include -4 and all real numbers between -4 and 3 , illustrated in red on the x -axis. The bracket at -4 indicates that -4 is included in the interval. The parenthesis at 3 indicates that 3 is not included in the interval. The **domain** is $\{x \mid -4 \leq x < 3\}$, or $[-4, 3)$. The outputs of the function include 5 and all real numbers between 2 and 5 , illustrated in blue on the y -axis. The parenthesis at 2 indicates that 2 is not included in the interval. The bracket at 5 indicates that 5 is included in the interval. The **range** is $\{y \mid 2 < y \leq 5\}$, or $(2, 5]$.

EXAMPLE 10 Graph each of the following functions. Then estimate the domain and the range of each.

a) $f(x) = \frac{1}{2}x + 1$

c) $f(x) = x^3 - x$

e) $f(x) = x^4 - 2x^2 - 3$

b) $f(x) = \sqrt{x + 4}$

d) $f(x) = \frac{1}{x - 2}$

f) $f(x) = \sqrt{4 - (x - 3)^2}$

Solution

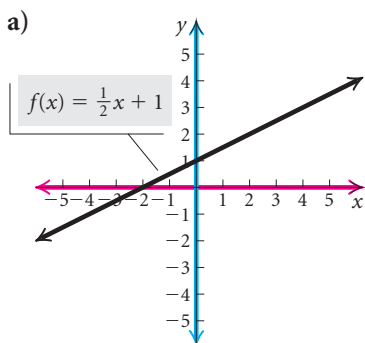

Domain = all real numbers, $(-\infty, \infty)$; range = all real numbers, $(-\infty, \infty)$

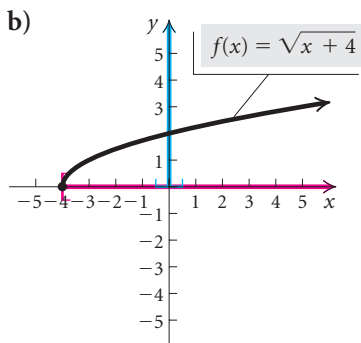

Domain = $[-4, \infty)$;
range = $[0, \infty)$

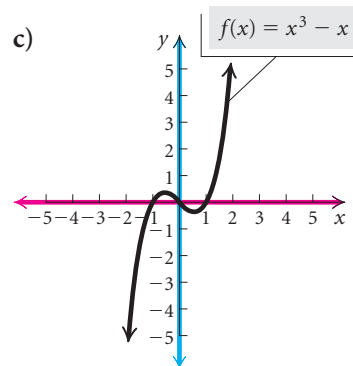

Domain = all real numbers, $(-\infty, \infty)$; range = all real numbers, $(-\infty, \infty)$

d)

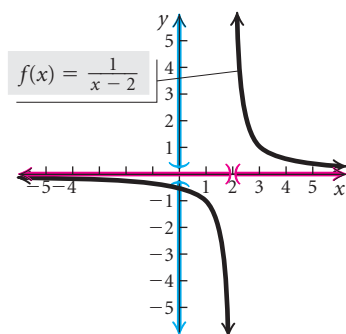

Since the graph does not touch or cross either the vertical line $x = 2$ or the x -axis, $y = 0$, 2 is excluded from the domain and 0 is excluded from the range.

Domain = $(-\infty, 2) \cup (2, \infty)$;
range = $(-\infty, 0) \cup (0, \infty)$

e)

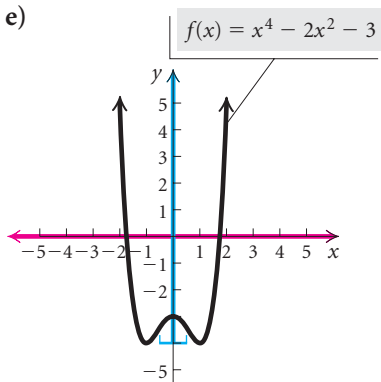

Domain = all real numbers,
 $(-\infty, \infty)$; range = $[-4, \infty)$

f)

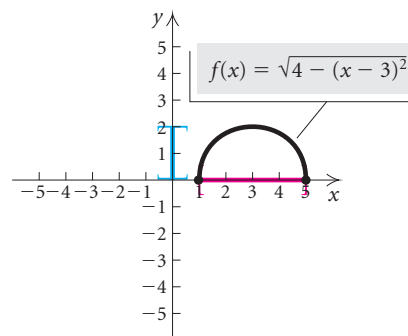

Domain = $[1, 5]$;
range = $[0, 2]$

➔ Now Try Exercises 71 and 77.

Always consider adding the reasoning of Example 9 to a graphical analysis. Think, “What can I input?” to find the domain. Think, “What do I get out?” to find the range. Thus, in Examples 10(c) and 10(e), it might not appear as though the domain is all real numbers because the graph rises steeply, but by examining the equation we see that we can indeed substitute any real number for x .



► Applications of Functions

EXAMPLE 11 *Linear Expansion of a Bridge.* The linear expansion L of the steel center span of a suspension bridge that is 1420 m long is a function of the change in temperature t , in degrees Celsius, from winter to summer and is given by

$$L(t) = 0.000013 \cdot 1420 \cdot t,$$

where 0.000013 is the coefficient of linear expansion for steel and L is in meters. Find the linear expansion of the steel center span when the change in temperature from winter to summer is 30° , 42° , 50° , and 56° Celsius.

Solution Using a calculator, we compute function values. We find that

$$L(30) = 0.5538 \text{ m,}$$

$$L(42) = 0.77532 \text{ m,}$$

$$L(50) = 0.923 \text{ m, and}$$

$$L(56) = 1.03376 \text{ m.}$$

➔ Now Try Exercise 83.

CONNECTING THE CONCEPTS

FUNCTION CONCEPTS

Formula for f : $f(x) = 5 + 2x^2 - x^4$.

For every input, there is exactly one output.

$(1, 6)$ is on the graph.

For the input 1, the output is 6.

$f(1) = 6$

Domain: set of all inputs = $(-\infty, \infty)$

Range: set of all outputs = $(-\infty, 6]$

GRAPH

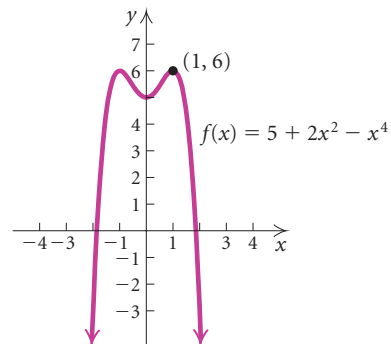

1.2

Exercise Set

In Exercises 1–14, determine whether the correspondence is a function.

1. $a \rightarrow w$

$b \rightarrow y$

$c \rightarrow z$

3. $-6 \rightarrow 36$

$-2 \rightarrow 4$

$2 \rightarrow 4$

5. $m \rightarrow A$

$n \rightarrow B$

$r \rightarrow C$

$s \rightarrow D$

2. $m \rightarrow q$

$n \rightarrow r$

$o \rightarrow s$

4. $-3 \rightarrow 2$

$1 \rightarrow 4$

$5 \rightarrow 6$

$9 \rightarrow 8$

6. $a \rightarrow r$

$b \rightarrow s$

$c \rightarrow t$

$d \rightarrow t$

7.

BOOK TITLE	AMERICAN NOVELIST
<i>The Color Purple</i> , 1982 (Pulitzer Prize 1983)	Ray Bradbury
<i>East of Eden</i> , 1952	Pearl Buck
<i>Fahrenheit 451</i> , 1953	Ernest Hemingway
<i>The Good Earth</i> , 1931 (Pulitzer Prize 1932)	Harper Lee
<i>For Whom the Bell Tolls</i> , 1940	John Steinbeck
<i>The Grapes of Wrath</i> , 1939 (Pulitzer Prize 1940)	Alice Walker
<i>To Kill a Mockingbird</i> , 1960 (Pulitzer Prize 1961)	Eudora Welty
<i>The Old Man and the Sea</i> , 1952 (Pulitzer Prize 1953)	
<i>The Optimist's Daughter</i> , 1972 (Pulitzer Prize 1973)	

8.

ACTOR PORTRAYING

JAMES BOND

MOVIE TITLE

Sean Connery	→	<i>Goldfinger</i> , 1964
George Lazenby	→	<i>On Her Majesty's Secret Service</i> , 1969
Roger Moore	→	<i>Diamonds Are Forever</i> , 1971
	→	<i>Moonraker</i> , 1979
Timothy Dalton	→	<i>For Your Eyes Only</i> , 1981
	→	<i>The Living Daylights</i> , 1987
Pierce Brosnan	→	<i>GoldenEye</i> , 1995
	→	<i>The World Is Not Enough</i> , 1999
Daniel Craig	→	<i>Quantum of Solace</i> , 2008

DOMAIN	CORRESPONDENCE	RANGE
9. A set of cars in a parking lot	Each car's license number	A set of letters and numbers
10. A set of people in a town	A doctor a person uses	A set of doctors
11. The integers less than 9	Five times the integer	A subset of integers
12. A set of members of a rock band	An instrument each person plays	A set of instruments
13. A set of students in a class	A student sitting in a neighboring seat	A set of students
14. A set of bags of chips on a shelf	Each bag's weight	A set of weights

Determine whether the relation is a function. Identify the domain and the range.

15. $\{(2, 10), (3, 15), (4, 20)\}$
16. $\{(3, 1), (5, 1), (7, 1)\}$
17. $\{(-7, 3), (-2, 1), (-2, 4), (0, 7)\}$
18. $\{(1, 3), (1, 5), (1, 7), (1, 9)\}$

19. $\{(-2, 1), (0, 1), (2, 1), (4, 1), (-3, 1)\}$

20. $\{(5, 0), (3, -1), (0, 0), (5, -1), (3, -2)\}$

21. Given that $g(x) = 3x^2 - 2x + 1$, find each of the following.

- a) $g(0)$
- b) $g(-1)$
- c) $g(3)$
- d) $g(-x)$
- e) $g(1 - t)$

22. Given that $f(x) = 5x^2 + 4x$, find each of the following.

- a) $f(0)$
- b) $f(-1)$
- c) $f(3)$
- d) $f(t)$
- e) $f(t - 1)$

23. Given that $g(x) = x^3$, find each of the following.

- a) $g(2)$
- b) $g(-2)$
- c) $g(-x)$
- d) $g(3y)$
- e) $g(2 + h)$

24. Given that $f(x) = 2|x| + 3x$, find each of the following.

- a) $f(1)$
- b) $f(-2)$
- c) $f(-x)$
- d) $f(2y)$
- e) $f(2 - h)$

25. Given that

$$g(x) = \frac{x - 4}{x + 3},$$

find each of the following.

- a) $g(5)$
- b) $g(4)$
- c) $g(-3)$
- d) $g(-16.25)$
- e) $g(x + h)$

26. Given that

$$f(x) = \frac{x}{2 - x},$$

find each of the following.

- a) $f(2)$
- b) $f(1)$
- c) $f(-16)$
- d) $f(-x)$
- e) $f\left(-\frac{2}{3}\right)$

27. Find $g(0)$, $g(-1)$, $g(5)$, and $g\left(\frac{1}{2}\right)$ for

$$g(x) = \frac{x}{\sqrt{1 - x^2}}.$$

28. Find $h(0)$, $h(2)$, and $h(-x)$ for

$$h(x) = x + \sqrt{x^2 - 1}.$$

Graph the function.

29. $f(x) = \frac{1}{2}x + 3$

30. $f(x) = \sqrt{x} - 1$

31. $f(x) = -x^2 + 4$

32. $f(x) = x^2 + 1$

33. $f(x) = \sqrt{x - 1}$

34. $f(x) = x - \frac{1}{2}x^3$

A graph of a function is shown. Using the graph, find the indicated function values; that is, given the inputs, find the outputs.

35. $h(1)$, $h(3)$, and $h(4)$

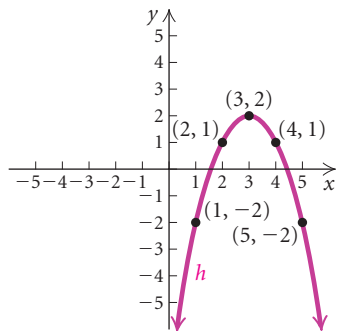

36. $t(-4)$, $t(0)$, and $t(3)$

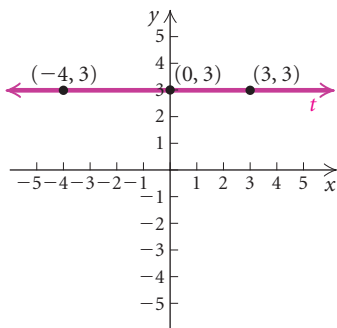

37. $s(-4)$, $s(-2)$, and $s(0)$

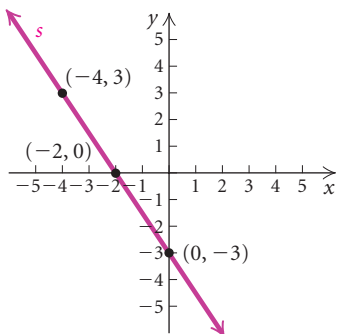

38. $g(-4)$, $g(-1)$, and $g(0)$

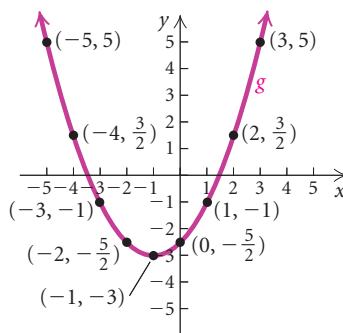

39. $f(-1)$, $f(0)$, and $f(1)$

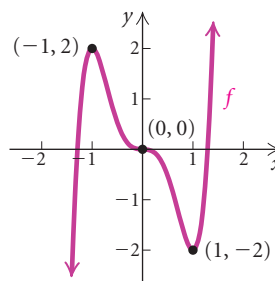

40. $g(-2)$, $g(0)$, and $g(2.4)$

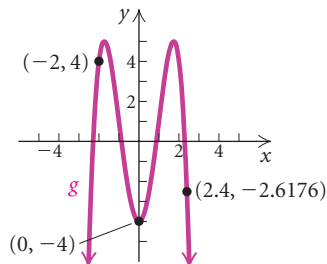

In Exercises 41–48, determine whether the graph is that of a function. An open circle indicates that the point does not belong to the graph.

41.

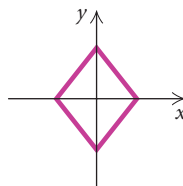

42.

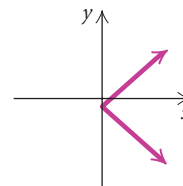

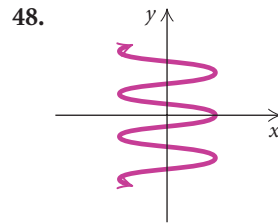
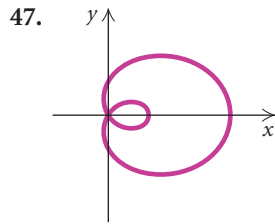
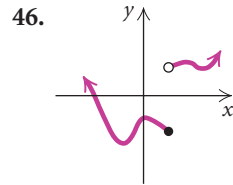
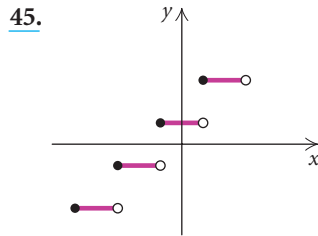
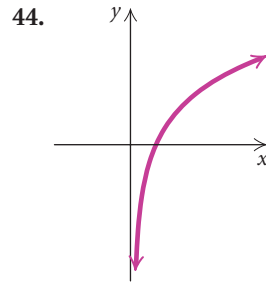
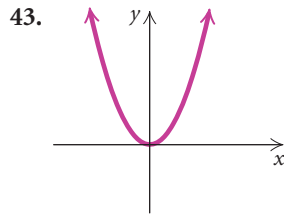

Find the domain of the function.

49. $f(x) = 7x + 4$

50. $f(x) = |3x - 2|$

51. $f(x) = |6 - x|$

52. $f(x) = \frac{1}{x^4}$

53. $f(x) = 4 - \frac{2}{x}$

54. $f(x) = \frac{1}{5}x^2 - 5$

55. $f(x) = \frac{x + 5}{2 - x}$

56. $f(x) = \frac{8}{x + 4}$

57. $f(x) = \frac{1}{x^2 - 4x - 5}$

58. $f(x) = \frac{(x - 2)(x + 9)}{x^3}$

59. $f(x) = \frac{8 - x}{x^2 - 7x}$

60. $f(x) = \frac{x^4 - 2x^3 + 7}{3x^2 - 10x - 8}$

61. $f(x) = \frac{1}{10}|x|$

62. $f(x) = x^2 - 2x$

In Exercises 63–70, determine the domain and the range of the function.

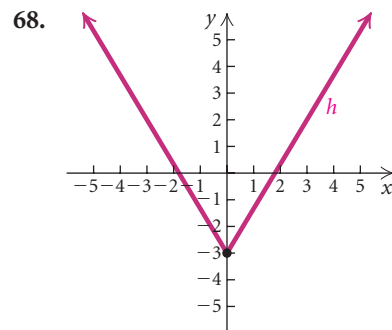
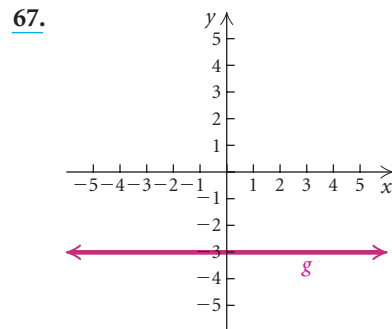
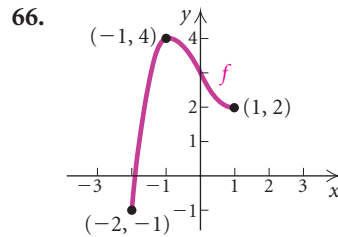
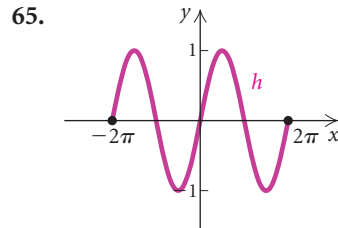
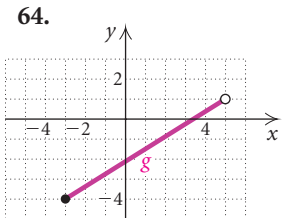
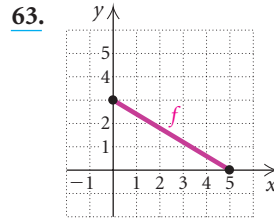

69.

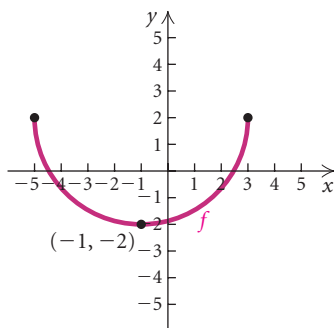

70.

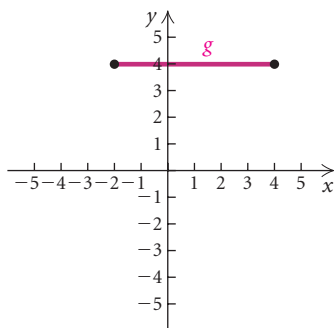

Graph the function. Then visually estimate the domain and the range.

71. $f(x) = |x|$

72. $f(x) = 5 - 3x$

73. $f(x) = 3x - 2$

74. $f(x) = \frac{1}{x+1}$

75. $f(x) = (x-1)^3 + 2$

76. $f(x) = (x-2)^4 + 1$

77. $f(x) = \sqrt{7-x}$

78. $f(x) = \sqrt{x+8}$

79. $f(x) = -x^2 + 4x - 1$

80. $f(x) = 2x^2 - x^4 + 5$

81. **Decreasing Value of the Dollar.** In 2005, it took \$19.37 to equal the value of \$1 in 1913. In 1990, it took only \$13.20 to equal the value of \$1 in 1913. The amount it takes to equal the value of \$1 in 1913 can be estimated by the linear function V given by

$$V(x) = 0.4123x + 13.2617,$$

where x is the number of years since 1990. Thus, $V(11)$ gives the amount it took in 2001 to equal the value of \$1 in 1913.



Source: U.S. Bureau of Labor Statistics

- a) Use this function to predict the amount it will take in 2015 and in 2020 to equal the value of \$1 in 1913.
- b) When will it take approximately \$30 to equal the value of \$1 in 1913?
82. **Windmill Power.** Under certain conditions, the power P , in watts per hour, generated by a windmill with winds blowing v miles per hour is given by

$$P(v) = 0.015v^3.$$

Find the power generated by 15-mph winds and 35-mph winds.



83. **Boiling Point and Elevation.** The elevation E , in meters, above sea level at which the boiling point of water is t degrees Celsius is given by the function
- $$E(t) = 1000(100 - t) + 580(100 - t)^2.$$
- At what elevation is the boiling point 99.5°? 100°?



Skill Maintenance

To the student and the instructor: The Skill Maintenance exercises review skills covered previously in the text. You can expect such exercises in every exercise set. They provide excellent review for a final examination.

Answers to all skill maintenance exercises, along with section references, appear in the answer section at the back of the book.

Use substitution to determine whether the given ordered pairs are solutions of the given equation.

84. $(-3, -2), (2, -3); y^2 - x^2 = -5$

85. $(0, -7), (8, 11); y = 0.5x + 7$

86. $(\frac{4}{5}, -2), (\frac{11}{5}, \frac{1}{10}); 15x - 10y = 32$

Graph the equation.

87. $y = (x - 1)^2$

88. $y = \frac{1}{3}x - 6$

89. $-2x - 5y = 10$

90. $(x - 3)^2 + y^2 = 4$

Synthesis

Find the domain of the function.

91. $f(x) = \sqrt[3]{x - 1}$

92. $f(x) = \sqrt[4]{2x + 5} + 3$

93. $f(x) = \sqrt{8 - x}$

94. $f(x) = \frac{\sqrt{x + 1}}{x}$

95. $f(x) = \frac{\sqrt{x + 6}}{(x + 2)(x - 3)}$

96. $f(x) = \frac{\sqrt{x - 1}}{x^2 + x - 6}$

97. $f(x) = \sqrt{3 - x} + \sqrt{x + 5}$

98. $f(x) = \sqrt{x} - \sqrt{4 - x}$

99. Give an example of two different functions that have the same domain and the same range, but have no pairs in common. Answers may vary.

100. Draw a graph of a function for which the domain is $[-4, 4]$ and the range is $[1, 2] \cup [3, 5]$. Answers may vary.

101. Suppose that for some function g , $g(x + 3) = 2x + 1$. Find $g(-1)$.

102. Suppose $f(x) = |x + 3| - |x - 4|$. Write $f(x)$ without using absolute-value notation if x is in each of the following intervals.

a) $(-\infty, -3)$

b) $[-3, 4)$

c) $[4, \infty)$

Linear Functions, Slope, and Applications

1.3

- ▶ Determine the slope of a line given two points on the line.
- ▶ Solve applied problems involving slope, or average rate of change.
- ▶ Find the slope and the y -intercept of a line given the equation $y = mx + b$, or $f(x) = mx + b$.
- ▶ Graph a linear equation using the slope and the y -intercept.
- ▶ Solve applied problems involving linear functions.

In real-life situations, we often need to make decisions on the basis of limited information. When the given information is used to formulate an equation or an inequality that at least approximates the situation mathematically, we have created a **model**. One of the most frequently used mathematical models is *linear*. The graph of a linear model is a straight line.

▶ Linear Functions

Let's begin to examine the connections among equations, functions, and graphs that are straight lines. Compare the graphs of linear functions and nonlinear functions shown on the following page.

Linear Functions

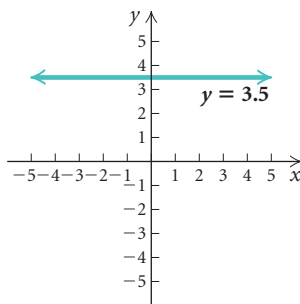
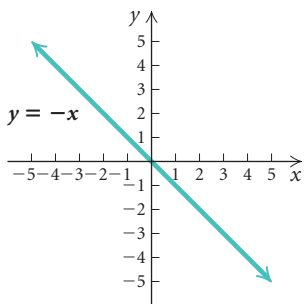

Nonlinear Functions

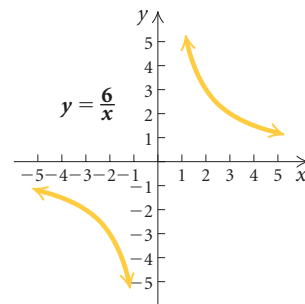
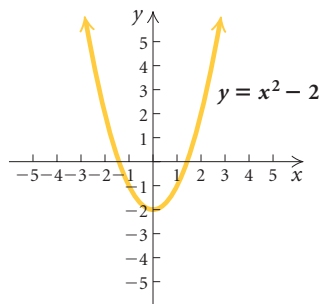

We have the following conclusions and related terminology.

Linear Functions

A function f is a **linear function** if it can be written as

$$f(x) = mx + b,$$

where m and b are constants.

If $m = 0$, the function is a **constant function** $f(x) = b$. If $m = 1$ and $b = 0$, the function is the **identity function** $f(x) = x$.

Linear function:
 $y = mx + b$

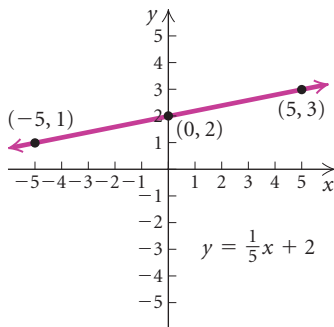

Identity function:
 $y = 1 \cdot x + 0$, or $y = x$

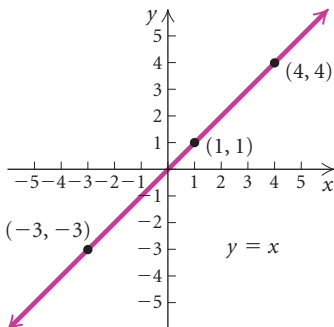

Constant function:
 $y = 0 \cdot x + b$, or $y = b$ (Horizontal line)

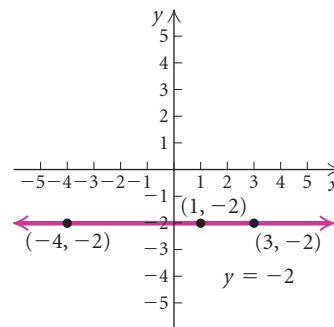

Vertical line: $x = a$
(not a function)

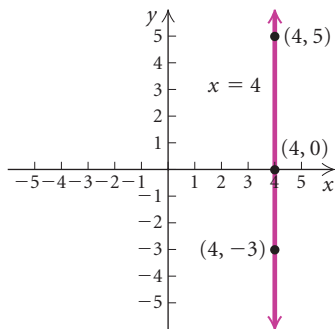

Horizontal Lines and Vertical Lines

Horizontal lines are given by equations of the type $y = b$ or $f(x) = b$. (They are functions.)

Vertical lines are given by equations of the type $x = a$. (They are *not* functions.)

► The Linear Function $f(x) = mx + b$ and Slope

To attach meaning to the constant m in the equation $f(x) = mx + b$, we first consider an application. Suppose Quality Foods is a wholesale supplier to restaurants that currently has stores in locations A and B in a large city. Their total operating costs for the same time period are given by the two functions shown in the tables and graphs that follow. The variable x represents time, in months. The variable y represents total costs, in thousands of dollars, over that period of time. Look for a pattern.

x	y
10	\$50
20	100
30	150
40	200
50	250
60	300
70	350
80	400

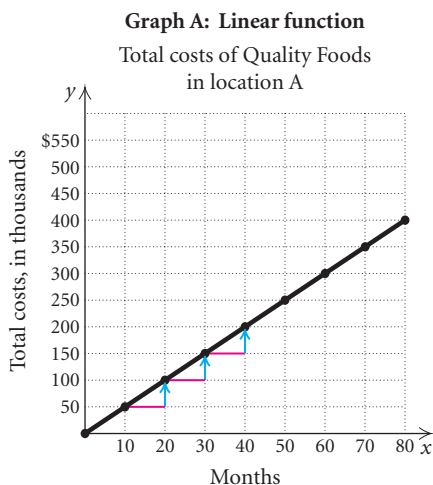

x	y
10	\$10
20	30
30	70
40	130
50	210
60	310
70	430
80	570

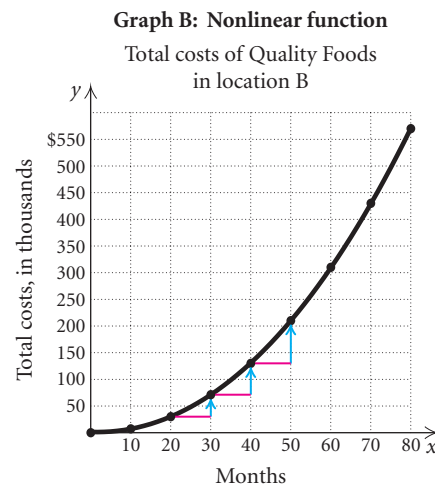

We see in graph A that *every* change of 10 months results in a \$50 thousand change in total costs. But in graph B, changes of 10 months do *not* result in constant changes in total costs. This is a way to distinguish linear functions from nonlinear functions. The rate at which a linear function changes, or the steepness of its graph, is constant.

Mathematically, we define the steepness, or **slope**, of a line as the ratio of its vertical change (*rise*) to the corresponding horizontal change (*run*). Slope represents the **rate of change** of y with respect to x .

Slope

The **slope** m of a line containing points (x_1, y_1) and (x_2, y_2) is given by

$$\begin{aligned}
 m &= \frac{\text{rise}}{\text{run}} \\
 &= \frac{\text{the change in } y}{\text{the change in } x} \\
 &= \frac{y_2 - y_1}{x_2 - x_1} = \frac{y_1 - y_2}{x_1 - x_2}.
 \end{aligned}$$

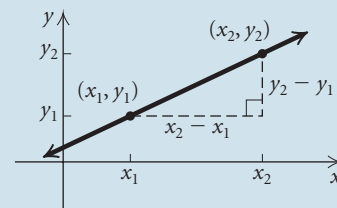

TECHNOLOGY CONNECTION

We can animate the effect of the slope m in linear functions of the type $f(x) = mx$ with a graphing calculator. Graph the equations

$$y_1 = x, \quad y_2 = 2x,$$

$$y_3 = 5x, \quad \text{and} \quad y_4 = 10x$$

by entering them as

$$y_1 = \{1, 2, 5, 10\}x.$$

What do you think the graph of $y = 128x$ will look like?

Clear the screen and graph the following equations:

$$y_1 = x, \quad y_2 = 0.75x,$$

$$y_3 = 0.48x, \quad \text{and} \quad y_4 = 0.12x.$$

What do you think the graph of $y = 0.000029x$ will look like?

Again clear the screen and graph each set of equations:

$$y_1 = -x, \quad y_2 = -2x,$$

$$y_3 = -4x, \quad \text{and} \quad y_4 = -10x$$

and

$$y_1 = -x, \quad y_2 = -\frac{2}{3}x,$$

$$y_3 = -\frac{7}{20}x, \quad \text{and} \quad y_4 = -\frac{1}{10}x.$$

From your observations, what do you think the graphs of $y = -200x$ and $y = -\frac{17}{100,000}x$ will look like?

How does the value of m affect the graph of a function of the form $f(x) = mx$?

EXAMPLE 1 Graph the function $f(x) = -\frac{2}{3}x + 1$ and determine its slope.

Solution Since the equation for f is in the form $f(x) = mx + b$, we know that it is a linear function. We can graph it by connecting two points on the graph with a straight line. We calculate two ordered pairs, plot the points, graph the function, and determine the slope:

$$f(3) = -\frac{2}{3} \cdot 3 + 1 = -2 + 1 = -1;$$

$$f(9) = -\frac{2}{3} \cdot 9 + 1 = -6 + 1 = -5;$$

Pairs: $(3, -1)$, $(9, -5)$;

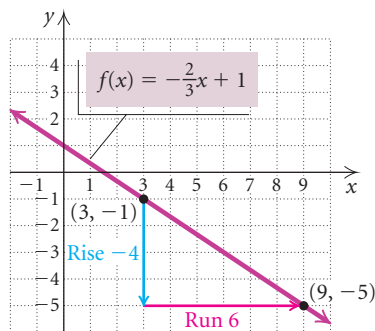

$$\begin{aligned} \text{Slope} = m &= \frac{f(x_2) - f(x_1)}{x_2 - x_1} \\ &= \frac{y_2 - y_1}{x_2 - x_1} \\ &= \frac{-5 - (-1)}{9 - 3} = \frac{-4}{6} = -\frac{2}{3}. \end{aligned}$$

The slope is the same for any two points on a line. Thus, to check our work, note that $f(6) = -\frac{2}{3} \cdot 6 + 1 = -4 + 1 = -3$. Using the points $(6, -3)$ and $(3, -1)$, we have

$$m = \frac{-1 - (-3)}{3 - 6} = \frac{2}{-3} = -\frac{2}{3}.$$

We can also use the points in the opposite order when computing slope:

$$m = \frac{-3 - (-1)}{6 - 3} = \frac{-2}{3} = -\frac{2}{3}.$$

Note too that the slope of the line is the number m in the equation for the function, $f(x) = -\frac{2}{3}x + 1$.

Now Try Exercise 7.

The slope of the line given by $f(x) = mx + b$ is m .

If a line slants up from left to right, the change in x and the change in y have the same sign, so the line has a positive slope. The larger the slope, the steeper the line, as shown in Fig. 1. If a line slants down from left to right, the change in x and the change in y are of opposite signs, so the line has a negative slope. The larger the absolute value of the slope, the steeper the line, as shown in Fig. 2. Considering $y = mx$ when $m = 0$, we have $y = 0x$, or $y = 0$. Note that this horizontal line is the x -axis, as shown in Fig. 3.

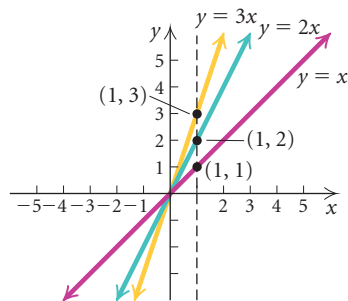

Figure 1

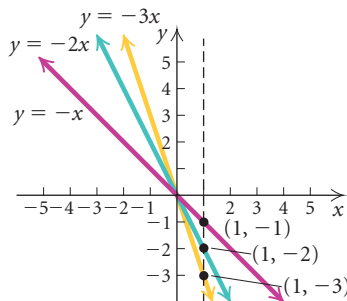

Figure 2

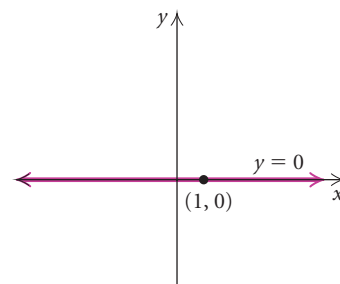

Figure 3

STUDY TIP

Are you aware of all the learning resources that exist for this textbook? Many details are given in the preface. The *Student's Solutions Manual* contains worked-out solutions to the odd-numbered exercises in the exercise sets and to all the exercises in the end-of-chapter material.

Horizontal Lines and Vertical Lines

If a line is horizontal, the change in y for any two points is 0 and the change in x is nonzero. Thus a horizontal line has slope 0. (See Fig. 4.)

If a line is vertical, the change in y for any two points is nonzero and the change in x is 0. Thus the slope is *not defined* because we cannot divide by 0. (See Fig. 5.)

Horizontal lines

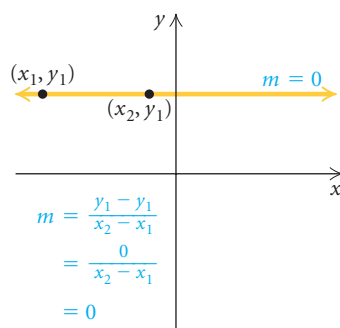

Figure 4

Vertical lines

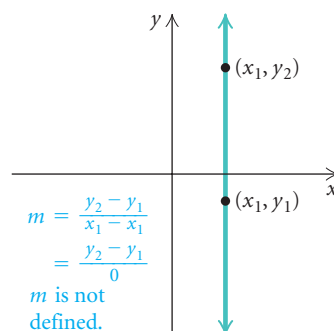

Figure 5

Note that zero slope and an undefined slope are two very different concepts.

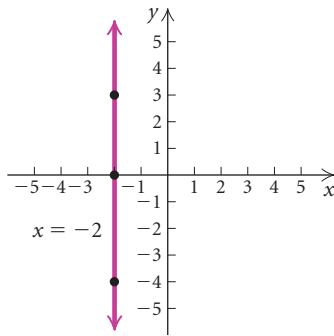

Figure 6

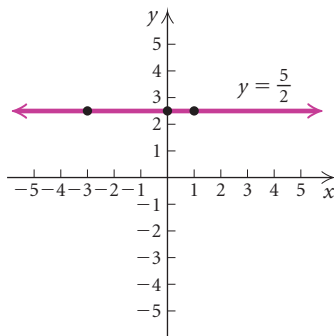

Figure 7

EXAMPLE 2 Graph each linear equation and determine its slope.

a) $x = -2$

b) $y = \frac{5}{2}$

Solution

a) Since y is missing in $x = -2$, any value for y will do.

x	y
-2	0
-2	3
-2	-4

Choose any number for y ; x must be -2 .

The graph is a *vertical line* 2 units to the left of the y -axis. (See Fig. 6.) The slope is not defined. The graph is *not* the graph of a function.

b) Since x is missing in $y = \frac{5}{2}$, any value for x will do.

x	y
0	$\frac{5}{2}$
-3	$\frac{5}{2}$
1	$\frac{5}{2}$

Choose any number for x ; y must be $\frac{5}{2}$.

The graph is a *horizontal line* $\frac{5}{2}$, or $2\frac{1}{2}$, units above the x -axis. (See Fig. 7.) The slope is 0. The graph is the graph of a constant function.

➔ Now Try Exercises 17 and 23.

► Applications of Slope

Slope has many real-world applications. Numbers like 2%, 4%, and 7% are often used to represent the **grade** of a road. Such a number is meant to tell how steep a road is on a hill or a mountain. For example, a 4% grade means that the road rises (or falls) 4 ft for every horizontal distance of 100 ft.

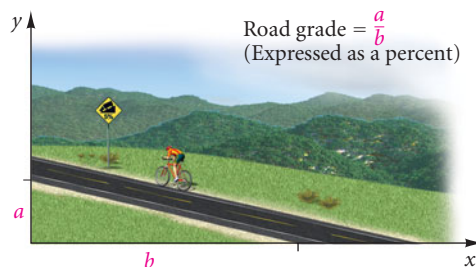

Whistler's bobsled/luge course for the 2010 Winter Olympics in Vancouver, British Columbia, was the fastest-ever Olympic course. The vertical drop for the course is 499 ft. The maximum slope of the track is 20% at Curve 2. (Source: Ron Judd, *The Seattle Times*)



The concept of grade is also used with a treadmill. During a treadmill test, a cardiologist might change the slope, or grade, of the treadmill to measure its effect on heart rate.



Another example occurs in hydrology. The strength or force of a river depends on how far the river falls vertically compared to how far it flows horizontally.

EXAMPLE 3 *Ramp for the Disabled.* Construction laws regarding access ramps for the disabled state that every vertical rise of 1 ft requires a horizontal run of at least 12 ft. What is the grade, or slope, of such a ramp?

Solution The grade, or slope, is given by $m = \frac{1}{12} \approx 0.083 = 8.3\%$.

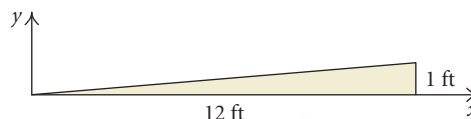

Average Rate of Change

Slope can also be considered as an **average rate of change**. To find the average rate of change between any two data points on a graph, we determine the slope of the line that passes through the two points.

EXAMPLE 4 Adolescent Obesity. The percent of American adolescents ages 12 to 19 who are obese increased from about 6.5% in 1985 to 18% in 2008. The graph below illustrates this trend. Find the average rate of change in the percent of adolescents who are obese from 1985 to 2008.



Jamie Oliver's first U.S. network TV series, *Jamie Oliver's Revolution*, won an Emmy award in August 2010. Jamie's goal is to save America's health by changing the way we eat.

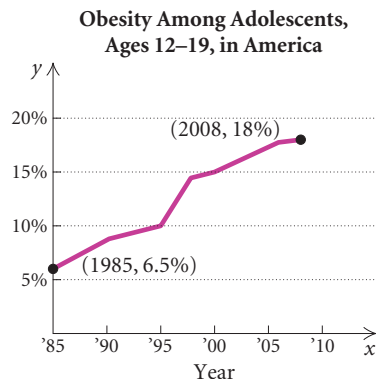

Source: National Center for Health Statistics, a division of the U.S. Centers for Disease Control and Prevention

Solution We use the coordinates of two points on the graph. In this case, we use (1985, 6.5%) and (2008, 18%). Then we compute the slope, or average rate of change, as follows:

$$\begin{aligned} \text{Slope} = \text{Average rate of change} &= \frac{\text{Change in } y}{\text{Change in } x} \\ &= \frac{18\% - 6.5\%}{2008 - 1985} = \frac{11.5\%}{23} \approx 0.5\%. \end{aligned}$$

The result tells us that each year from 1985 to 2008, the percent of adolescents who are obese increased an average of 0.5%. The average rate of change over this 23-year period was an increase of 0.5% per year.

Now Try Exercise 41.

EXAMPLE 5 Snowboard Sales. Sales of snowboards decreased from 2005 to 2009. In 2005, 336,966 snowboards were sold in specialty shops in the United States. This number decreased to 287,524 in 2009. (*Source: SIA Retail Audit*) Find the average rate of change in snowboard sales from 2005 to 2009.

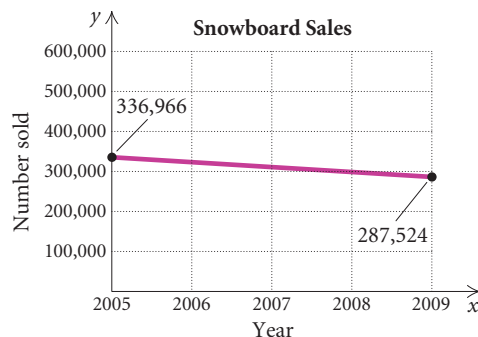

TECHNOLOGY CONNECTION

We can use a graphing calculator to explore the effect of the constant b in linear equations of the type $f(x) = mx + b$. Begin with the graph of $y = x$. Now graph the lines $y = x + 3$ and $y = x - 4$ in the same viewing window. Try entering these equations as $y = x + \{0, 3, -4\}$ and compare the graphs. How do the last two lines differ from $y = x$? What do you think the line $y = x - 6$ will look like?

Clear the first set of equations and graph $y = -0.5x$, $y = -0.5x + 3$, and $y = -0.5x - 4$ in the same viewing window. Describe what happens to the graph of $y = -0.5x$ when a number b is added.

y-INTERCEPT

REVIEW SECTION 1.1

Solution Using the points (2005, 336,966) and (2009, 287,524), we compute the slope of the line containing these two points.

$$\begin{aligned} \text{Slope} = \text{Average rate of change} &= \frac{\text{Change in } y}{\text{Change in } x} \\ &= \frac{287,524 - 336,966}{2009 - 2005} = \frac{-49,442}{4} \approx -12,361. \end{aligned}$$

The result tells us that each year from 2005 to 2009, the sales of snowboards decreased on average by 12,361. The average rate of change over the 4-year period was a decrease of 12,361 snowboards per year.

Now Try Exercise 47.

► Slope–Intercept Equations of Lines

Let's explore the effect of the constant b in linear equations of the type $f(x) = mx + b$. Compare the graphs of the equations

$$y = 3x \quad \text{and} \quad y = 3x - 2.$$

Note that the graph of $y = 3x - 2$ is a shift of the graph of $y = 3x$ down 2 units and that $y = 3x - 2$ has y -intercept $(0, -2)$. That is, the graph is parallel to $y = 3x$ and it crosses the y -axis at $(0, -2)$. The point $(0, -2)$ is the **y -intercept** of the graph.

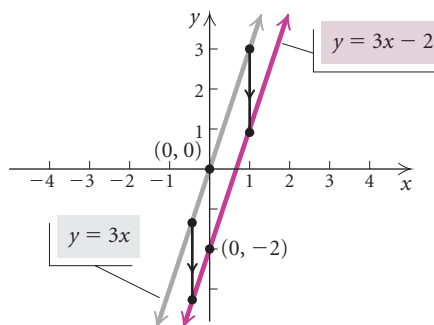

The Slope–Intercept Equation

The linear function f given by

$$f(x) = mx + b$$

is written in slope–intercept form. The graph of an equation in this form is a straight line parallel to $f(x) = mx$. The constant m is called the slope, and the y -intercept is $(0, b)$.

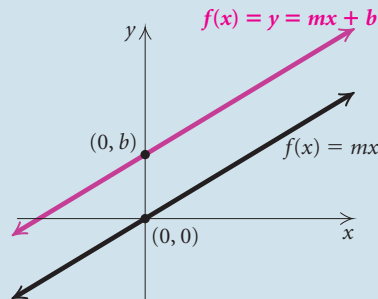

We can read the slope m and the y -intercept $(0, b)$ directly from the equation of a line written in slope–intercept form $y = mx + b$.

EXAMPLE 6 Find the slope and the y -intercept of the line with equation $y = -0.25x - 3.8$.

Solution

$$y = \underbrace{-0.25}x \underbrace{- 3.8}$$

$$\text{Slope} = -0.25; \quad y\text{-intercept} = (0, -3.8)$$

➔ Now Try Exercise 49.

Any equation whose graph is a straight line is a **linear equation**. To find the slope and the y -intercept of the graph of a nonvertical linear equation, we can solve for y , and then read the information from the equation.

EXAMPLE 7 Find the slope and the y -intercept of the line with equation $3x - 6y - 7 = 0$.

Solution We solve for y :

$$3x - 6y - 7 = 0$$

$$-6y = -3x + 7$$

Adding $-3x$ and 7 on both sides

$$-\frac{1}{6}(-6y) = -\frac{1}{6}(-3x + 7)$$

Multiplying by $-\frac{1}{6}$

$$y = \frac{1}{2}x - \frac{7}{6}$$

Thus the slope is $\frac{1}{2}$, and the y -intercept is $(0, -\frac{7}{6})$.

➔ Now Try Exercise 61.

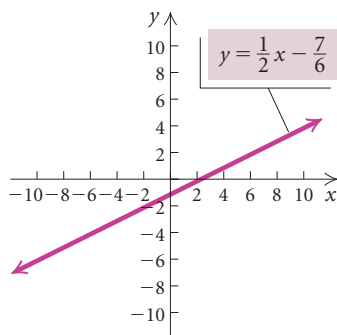
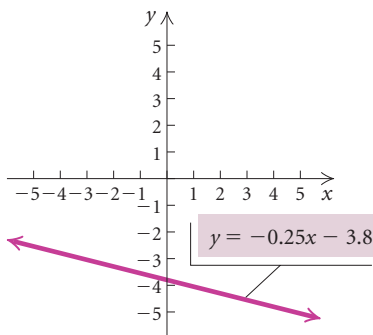

► Graphing $f(x) = mx + b$ Using m and b

We can also graph a linear equation using its slope and y -intercept.

EXAMPLE 8 Graph: $y = -\frac{2}{3}x + 4$.

Solution This equation is in slope–intercept form, $y = mx + b$. The y -intercept is $(0, 4)$. We plot this point. We can think of the slope ($m = -\frac{2}{3}$) as $-\frac{2}{3}$.

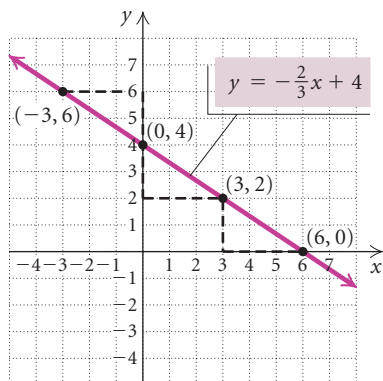

$$m = \frac{\text{rise}}{\text{run}} = \frac{\text{change in } y}{\text{change in } x} = \frac{-2}{3} \leftarrow \text{Move 2 units down.}$$

$$\leftarrow \text{Move 3 units to the right.}$$

Starting at the y -intercept and using the slope, we find another point by moving 2 units down and 3 units to the right. We get a new point $(3, 2)$. In a similar manner, we can move from $(3, 2)$ to find another point $(6, 0)$.

We could also think of the slope ($m = -\frac{2}{3}$) as $\frac{2}{3}$. Then we can start at $(0, 4)$ and move 2 units up and 3 units to the left. We get to another point on the graph, $(-3, 6)$. We now plot the points and draw the line. Note that we need only the y -intercept and one other point in order to graph the line, but it's a good idea to find a third point as a check that the first two points are correct.

➔ Now Try Exercise 63.

► Applications of Linear Functions

We now consider an application of linear functions.

EXAMPLE 9 *Estimating Adult Height.* There is no proven way to predict a child's adult height, but there is a linear function that can be used to estimate the adult height of a child, given the sum of the child's parents' heights. The adult height M , in inches, of a male child whose parents' total height is x , in inches, can be estimated with the function

$$M(x) = 0.5x + 2.5.$$

The adult height F , in inches, of a female child whose parents' total height is x , in inches, can be estimated with the function

$$F(x) = 0.5x - 2.5.$$

(Source: Jay L. Hoecker, M.D., MayoClinic.com) Estimate the height of a female child whose parents' total height is 135 in. What is the domain of this function?

Solution We substitute in the function:

$$F(135) = 0.5(135) - 2.5 = 65.$$

Thus we can estimate the adult height of the female child as 65 in., or 5 ft 5 in.

Theoretically, the domain of the function is the set of all real numbers. However, the context of the problem dictates a different domain. Thus the domain consists of all positive real numbers—that is, the interval $(0, \infty)$. A more realistic domain might be 100 in. to 170 in.—that is, the interval $[100, 170]$.

➔ Now Try Exercise 73.



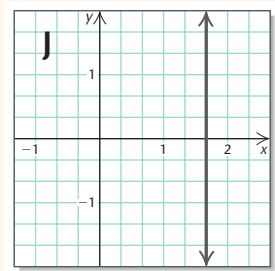
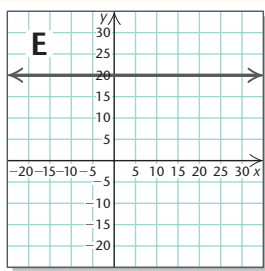
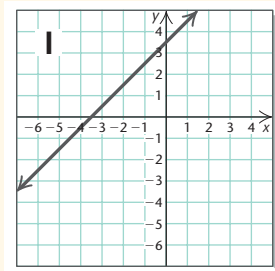
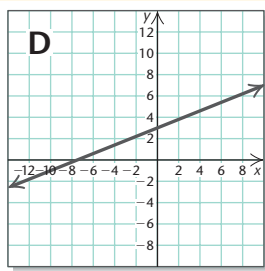
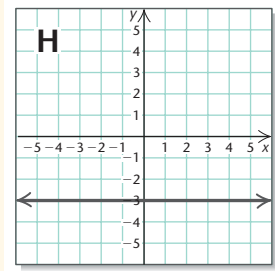
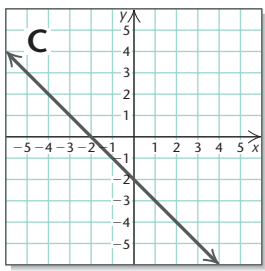
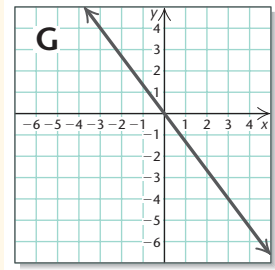
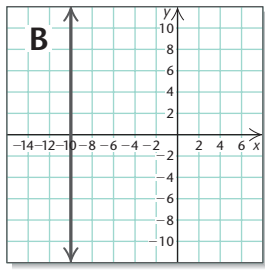
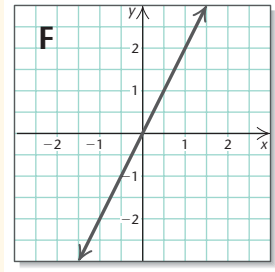
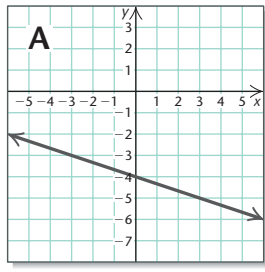

Visualizing the Graph

Match the equation with its graph.

1. $y = 20$
2. $5y = 2x + 15$
3. $y = -\frac{1}{3}x - 4$
4. $x = \frac{5}{3}$
5. $y = -x - 2$
6. $y = 2x$
7. $y = -3$
8. $3y = -4x$
9. $x = -10$
10. $y = x + \frac{7}{2}$

Answers on page A-6

1.3 Exercise Set

In Exercises 1–4, the table of data lists input–output values for a function. Answer the following questions for each table.

- Is the change in the inputs x the same?
- Is the change in the outputs y the same?
- Is the function linear?

1.

x	y
-3	7
-2	10
-1	13
0	16
1	19
2	22
3	25

2.

x	y
20	12.4
30	24.8
40	49.6
50	99.2
60	198.4
70	396.8
80	793.6

3.

x	y
11	3.2
26	5.7
41	8.2
56	9.3
71	11.3
86	13.7
101	19.1

4.

x	y
2	-8
4	-12
6	-16
8	-20
10	-24
12	-28
14	-32

Find the slope of the line containing the given points.

5.

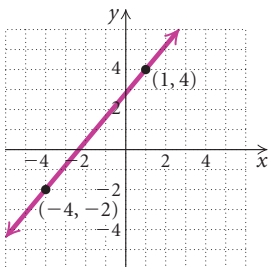

6.

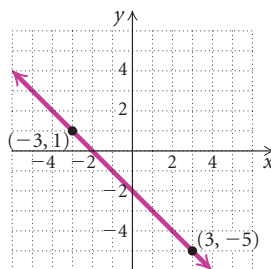

7.

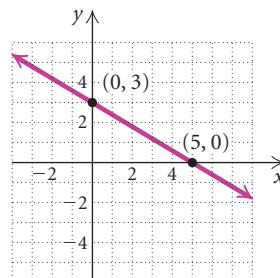

8.

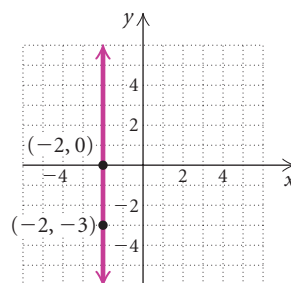

9.

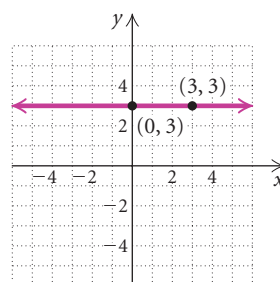

10.

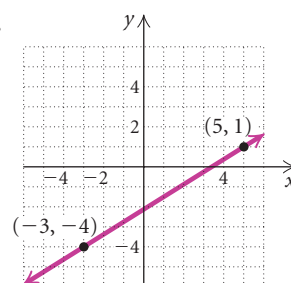

11. $(9, 4)$ and $(-1, 2)$
12. $(-3, 7)$ and $(5, -1)$
13. $(4, -9)$ and $(4, 6)$
14. $(-6, -1)$ and $(2, -13)$
15. $(0.7, -0.1)$ and $(-0.3, -0.4)$
16. $(-\frac{3}{4}, -\frac{1}{4})$ and $(\frac{2}{7}, -\frac{5}{7})$
17. $(2, -2)$ and $(4, -2)$
18. $(-9, 8)$ and $(7, -6)$
19. $(\frac{1}{2}, -\frac{3}{5})$ and $(-\frac{1}{2}, \frac{3}{5})$
20. $(-8.26, 4.04)$ and $(3.14, -2.16)$
21. $(16, -13)$ and $(-8, -5)$
22. $(\pi, -3)$ and $(\pi, 2)$
23. $(-10, -7)$ and $(-10, 7)$
24. $(\sqrt{2}, -4)$ and $(0.56, -4)$
25. $f(4) = 3$ and $f(-2) = 15$
26. $f(-4) = -5$ and $f(4) = 1$
27. $f(\frac{1}{5}) = \frac{1}{2}$ and $f(-1) = -\frac{11}{2}$
28. $f(8) = -1$ and $f(-\frac{2}{3}) = \frac{10}{3}$
29. $f(-6) = \frac{4}{5}$ and $f(0) = \frac{4}{5}$
30. $g(-\frac{9}{2}) = \frac{2}{9}$ and $g(\frac{2}{5}) = -\frac{5}{2}$

Determine the slope, if it exists, of the graph of the given linear equation.

31. $y = 1.3x - 5$
32. $y = -\frac{2}{5}x + 7$
33. $x = -2$
34. $f(x) = 4x - \frac{1}{4}$
35. $f(x) = -\frac{1}{2}x + 3$
36. $y = \frac{3}{4}$
37. $y = 9 - x$
38. $x = 8$
39. $y = 0.7$
40. $y = \frac{4}{5} - 2x$

41. **Private Jets.** To cut costs, many corporations have been selling their private jets. The number of used jets for sale worldwide has increased from 1022 in 1999 to 3014 in 2009 (Source: UBS Investment

Research). Find the average rate of change in the number of used jets for sale from 1999 to 2009.



42. **Highway Deaths.** In 2009, the traffic fatality rate in the United States was the lowest since the federal government began keeping records in 1966. There were 43,510 highway deaths in 2005. This number decreased to 33,963 in 2009. (Source: National Highway Traffic Safety Administration) Find the average rate of change in the number of highway deaths from 2005 to 2009.
43. **Coffee Consumption.** The U.S. annual per-capita consumption of coffee was 33.4 gal in 1970. By 2007, this amount had decreased to 24.6 gal. (Source: Economic Research Service, U.S. Department of Agriculture) Find the average rate of change in coffee consumption per capita from 1970 to 2007.
44. **Consumption of Broccoli.** The U.S. annual per-capita consumption of broccoli was 3.1 lb in 1990. By 2007, this amount had risen to 5.5 lb. (Source: Economic Research Service, U.S. Department of Agriculture) Find the average rate of change in the consumption of broccoli per capita from 1990 to 2007.



45. **Account Overdraft Fees.** Bank revenue from overdraft fees for checking accounts, ATMs, and debit cards is increasing in the United States. In 2003, account overdraft revenue was \$27.1 billion. By 2009, this amount had risen to \$38.5 billion. (Source: Moebs Services, R. K. Hammer Investment Bank) Find the average rate of change in account overdraft fees from 2003 to 2009.
46. **Credit-Card Penalties.** In 2009, bank credit-card penalties in the United States totaled \$20.5 billion. This amount was up from \$10.7 billion in 2003. (Source: Moebs Services, R. K. Hammer Investment Bank) Find the average rate of change in credit-card penalties over the 6-year period.
47. **Population Loss.** The population of Flint, Michigan, decreased from 124,943 in 2000 to 112,900 in 2008 (Source: U.S. Census Bureau). Find the average rate of change in the population of Flint, Michigan, over the 8-year period.
48. **Baled Hay.** In 2008, U.S. farmers received an average price of \$157 per ton for baled hay. In 2000, they received an average price of only \$84.60 per ton. (Source: National Agricultural Statistics Services, U.S. Department of Agriculture) Find the average rate of change in the price per ton of baled hay from 2000 to 2008.



Find the slope and the y -intercept of the line with the given equation.

49. $y = \frac{3}{5}x - 7$
50. $f(x) = -2x + 3$

51. $x = -\frac{2}{5}$
52. $y = \frac{4}{7}$
53. $f(x) = 5 - \frac{1}{2}x$
54. $y = 2 + \frac{3}{7}x$
55. $3x + 2y = 10$
56. $2x - 3y = 12$
57. $y = -6$
58. $x = 10$
59. $5y - 4x = 8$
60. $5x - 2y + 9 = 0$
61. $4y - x + 2 = 0$
62. $f(x) = 0.3 + x$

Graph the equation using the slope and the y -intercept.

63. $y = -\frac{1}{2}x - 3$
64. $y = \frac{3}{2}x + 1$
65. $f(x) = 3x - 1$
66. $f(x) = -2x + 5$
67. $3x - 4y = 20$
68. $2x + 3y = 15$
69. $x + 3y = 18$
70. $5y - 2x = -20$
71. **Pressure at Sea Depth.** The function P , given by

$$P(d) = \frac{1}{33}d + 1,$$

gives the pressure, in atmospheres (atm), at a depth d , in feet, under the sea. Find $P(0)$, $P(5)$, $P(10)$, $P(33)$, and $P(200)$.

72. **Minimum Ideal Weight.** One way to estimate the minimum ideal weight of a woman, in pounds, is to multiply her height, in inches, by 4 and subtract 130. Let W = the minimum ideal weight and h = height.
- a) Express W as a linear function of h .
- b) Find the minimum ideal weight of a woman whose height is 62 in.
73. **Estimating Adult Height.** Consider Example 9 and the function

$$M(x) = 0.5x + 2.5$$

for estimating the adult height of a male child.

- a) If the sum of the heights of the parents of a male child is 139 in., estimate the adult height of the child.
- b) What is the domain of M ?

74. **Stopping Distance on Glare Ice.** The stopping distance (at some fixed speed) of regular tires on glare ice is a function of the air temperature F , in degrees Fahrenheit. This function is estimated by

$$D(F) = 2F + 115,$$

where $D(F)$ is the stopping distance, in feet, when the air temperature is F , in degrees Fahrenheit.

- a) Find $D(0^\circ)$, $D(-20^\circ)$, $D(10^\circ)$, and $D(32^\circ)$.
- b) Explain why the domain should be restricted to $[-57.5^\circ, 32^\circ]$.
75. **Reaction Time.** Suppose that while driving a car, you suddenly see a deer standing in the road. Your brain registers the information and sends a signal to your foot to hit the brake. The car travels a distance D , in feet, during this time, where D is a function of the speed r , in miles per hour, of the car when you see the deer. That reaction distance is a linear function given by

$$D(r) = \frac{11}{10}r + \frac{1}{2}.$$

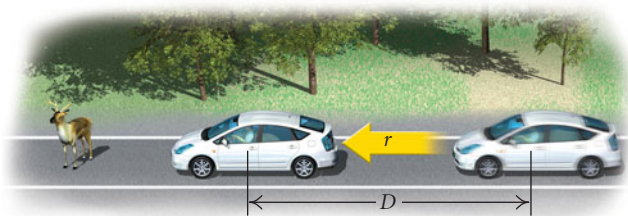

- a) Find the slope of this line and interpret its meaning in this application.
- b) Find $D(5)$, $D(10)$, $D(20)$, $D(50)$, and $D(65)$.
- c) What is the domain of this function? Explain.
76. **Straight-Line Depreciation.** A contractor buys a new truck for \$23,000. The truck is purchased on January 1 and is expected to last 5 years, at the end of which time its *trade-in*, or *salvage value* will be \$4500. If the company figures the decline or

depreciation in value to be the same each year, then the salvage value V , after t years, is given by the linear function

$$V(t) = \$23,000 - \$3700t, \quad \text{for } 0 \leq t \leq 5.$$

- a) Find $V(0)$, $V(1)$, $V(2)$, $V(3)$, and $V(5)$.
- b) Find the domain and the range of this function.
77. **Total Cost.** Steven buys a phone for \$89 and signs up for a Verizon nationwide plus Mexico single-line phone plan with 2000 monthly anytime minutes. The plan costs \$114.99 per month (*Source*: verizonwireless.com). Write an equation that can be used to determine the total cost, $C(t)$, of operating this Verizon phone plan for t months. Then find the cost for 24 months, assuming that the number of minutes Steven uses does not exceed 2000 per month.
78. **Total Cost.** Superior Cable Television charges a \$95 installation fee and \$125 per month for the Star plan. Write an equation that can be used to determine the total cost, $C(t)$, for t months of the Star plan. Then find the total cost for 18 months of service.

*In Exercises 79 and 80, the term **fixed costs** refers to the start-up costs of operating a business. This includes costs for machinery and building. The term **variable costs** refers to what it costs a business to produce or service one item.*

79. Ty's Custom Tees experienced fixed costs of \$800 and variable costs of \$3 per shirt. Write an equation that can be used to determine the total costs encountered by Ty's Custom Tees when x shirts are produced. Then determine the total cost of producing 75 shirts.
80. It's My Racquet experienced fixed costs of \$950 and variable costs of \$24 for each tennis racquet that is restring. Write an equation that can be used to determine the total costs encountered by It's My Racquet when x racquets are restring. Then determine the total cost of restringing 150 tennis racquets.

Skill Maintenance

If $f(x) = x^2 - 3x$, find each of the following.

81. $f\left(\frac{1}{2}\right)$

82. $f(5)$

83. $f(-5)$

84. $f(-a)$

85. $f(a + h)$

Synthesis

86. **Grade of Treadmills.** A treadmill is 5 ft long and is set at an 8% grade. How high is the end of the treadmill?

Find the slope of the line containing the given points.

87. $(-c, -d)$ and $(9c, -2d)$

88. $(r, s + t)$ and (r, s)

89. $(z + q, z)$ and $(z - q, z)$

90. $(-a - b, p + q)$ and $(a + b, p - q)$

91. (a, a^2) and $(a + h, (a + h)^2)$

92. $(a, 3a + 1)$ and $(a + h, 3(a + h) + 1)$

Suppose that f is a linear function. Determine whether the statement is true or false.

93. $f(cd) = f(c)f(d)$

94. $f(c + d) = f(c) + f(d)$

95. $f(c - d) = f(c) - f(d)$

96. $f(kx) = kf(x)$

Let $f(x) = mx + b$. Find a formula for $f(x)$ given each of the following.

97. $f(x + 2) = f(x) + 2$

98. $f(3x) = 3f(x)$

Mid-Chapter Mixed Review

Determine whether the statement is true or false.

- The x -intercept of the line that passes through $\left(-\frac{2}{3}, \frac{3}{2}\right)$ and the origin is $\left(-\frac{2}{3}, 0\right)$. [1.1]
- All functions are relations, but not all relations are functions. [1.2]
- The line parallel to the y -axis that passes through $(-5, 25)$ is $y = -5$. [1.3]
- Find the intercepts of the graph of the line $-8x + 5y = -40$. [1.1]

For each pair of points, find the distance between the points and the midpoint of the segment having the points as endpoints. [1.1]

- $(-8, -15)$ and $(3, 7)$
- $\left(-\frac{3}{4}, \frac{1}{5}\right)$ and $\left(\frac{1}{4}, -\frac{4}{5}\right)$
- Find an equation for a circle with center $(-5, 2)$ and radius of length 13. [1.1]
- Find the center and the radius of the circle $(x - 3)^2 + (y + 1)^2 = 4$. [1.1]

Graph the equation.

9. $3x - 6y = 6$ [1.1] 10. $y = -\frac{1}{2}x + 3$ [1.3]
11. $y = 2 - x^2$ [1.1] 12. $(x + 4)^2 + y^2 = 4$ [1.1]
13. Given that $f(x) = x - 2x^2$, find $f(-4)$, $f(0)$, and $f(1)$. [1.2]
14. Given that $g(x) = \frac{x + 6}{x - 3}$, find $g(-6)$, $g(0)$, and $g(3)$. [1.2]

Find the domain of the function. [1.2]

15. $g(x) = x + 9$ 16. $f(x) = \frac{-5}{x + 5}$ 17. $h(x) = \frac{1}{x^2 + 2x - 3}$

Graph the function. [1.2]

18. $f(x) = -2x$ 19. $g(x) = x^2 - 1$ 20. Determine the domain and the range of the function. [1.2]

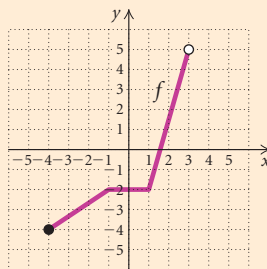

Find the slope of the line containing the given points. [1.3]

21. $(-2, 13)$ and $(-2, -5)$ 22. $(10, -1)$ and $(-6, 3)$ 23. $\left(\frac{5}{7}, \frac{1}{3}\right)$ and $\left(\frac{2}{7}, \frac{1}{3}\right)$

Determine the slope, if it exists, and the y -intercept of the line with the given equation. [1.3]

24. $f(x) = -\frac{1}{9}x + 12$ 25. $y = -6$
26. $x = 2$ 27. $3x - 16y + 1 = 0$

Collaborative Discussion and Writing

To the student and the instructor: The Collaborative Discussion and Writing exercises are meant to be answered with one or more sentences. They can be discussed and answered collaboratively by the entire class or by small groups.

28. Explain as you would to a fellow student how the numerical value of slope can be used to describe the slant and the steepness of a line. [1.3]
29. Discuss why the graph of a vertical line $x = a$ cannot represent a function. [1.3]
30. Explain in your own words the difference between the domain of a function and the range of a function. [1.2]
31. Explain how you could find the coordinates of a point $\frac{7}{8}$ of the way from point A to point B . [1.1]

Equations of Lines and Modeling

1.4

- ▶ Determine equations of lines.
- ▶ Given the equations of two lines, determine whether their graphs are parallel or perpendicular.
- ▶ Model a set of data with a linear function.

▶ Slope–Intercept Equations of Lines

In Section 1.3, we developed the slope–intercept equation $y = mx + b$, or $f(x) = mx + b$. If we know the slope and the y -intercept of a line, we can find an equation of the line using the slope–intercept equation.

EXAMPLE 1 A line has slope $-\frac{7}{9}$ and y -intercept $(0, 16)$. Find an equation of the line.

Solution We use the slope–intercept equation and substitute $-\frac{7}{9}$ for m and 16 for b :

$$y = mx + b$$

$$y = -\frac{7}{9}x + 16, \text{ or } f(x) = -\frac{7}{9}x + 16.$$

➔ Now Try Exercise 7.

EXAMPLE 2 A line has slope $-\frac{2}{3}$ and contains the point $(-3, 6)$. Find an equation of the line.

Solution We use the slope–intercept equation, $y = mx + b$, and substitute $-\frac{2}{3}$ for m : $y = -\frac{2}{3}x + b$. Using the point $(-3, 6)$, we substitute -3 for x and 6 for y in $y = -\frac{2}{3}x + b$. Then we solve for b .

$$y = mx + b$$

$$y = -\frac{2}{3}x + b \quad \text{Substituting } -\frac{2}{3} \text{ for } m$$

$$6 = -\frac{2}{3}(-3) + b \quad \text{Substituting } -3 \text{ for } x \text{ and } 6 \text{ for } y$$

$$6 = 2 + b$$

$$4 = b \quad \text{Solving for } b. \text{ The } y\text{-intercept is } (0, b).$$

The equation of the line is $y = -\frac{2}{3}x + 4$, or $f(x) = -\frac{2}{3}x + 4$.

➔ Now Try Exercise 13.

► Point–Slope Equations of Lines

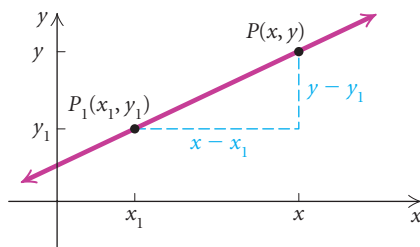

Another formula that can be used to determine an equation of a line is the *point–slope equation*. Suppose that we have a nonvertical line and that the coordinates of point P_1 on the line are (x_1, y_1) . We can think of P_1 as fixed and imagine another point P on the line with coordinates (x, y) . Thus the slope is given by

$$\frac{y - y_1}{x - x_1} = m.$$

Multiplying by $x - x_1$ on both sides, we get the *point–slope equation* of the line:

$$\begin{aligned} (x - x_1) \cdot \frac{y - y_1}{x - x_1} &= m \cdot (x - x_1) \\ y - y_1 &= m(x - x_1). \end{aligned}$$

Point–Slope Equation

The **point–slope equation** of the line with slope m passing through (x_1, y_1) is

$$y - y_1 = m(x - x_1).$$

If we know the slope of a line and the coordinates of one point on the line, we can find an equation of the line using either the **point–slope equation**,

$$y - y_1 = m(x - x_1),$$

or the **slope–intercept equation**,

$$y = mx + b.$$

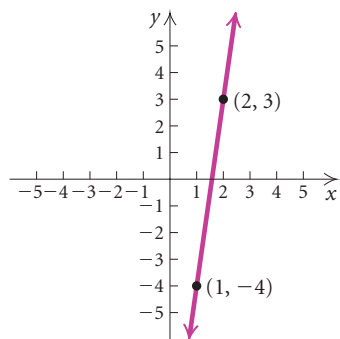

EXAMPLE 3 Find an equation of the line containing the points $(2, 3)$ and $(1, -4)$.

Solution We first determine the slope:

$$m = \frac{-4 - 3}{1 - 2} = \frac{-7}{-1} = 7.$$

Using the Point–Slope Equation: We substitute 7 for m and either of the points $(2, 3)$ or $(1, -4)$ for (x_1, y_1) in the point–slope equation. In this case, we use $(2, 3)$.

$$y - y_1 = m(x - x_1) \quad \text{Point–slope equation}$$

$$y - 3 = 7(x - 2) \quad \text{Substituting}$$

$$y - 3 = 7x - 14$$

$$y = 7x - 11, \text{ or } f(x) = 7x - 11$$

Using the Slope–Intercept Equation: We substitute 7 for m and either of the points $(2, 3)$ or $(1, -4)$ for (x, y) in the slope–intercept equation and solve for b . Here we use $(1, -4)$.

$$y = mx + b \quad \text{Slope–intercept equation}$$

$$-4 = 7 \cdot 1 + b \quad \text{Substituting}$$

$$-4 = 7 + b$$

$$-11 = b \quad \text{Solving for } b$$

We substitute 7 for m and -11 for b in $y = mx + b$ to get

$$y = 7x - 11, \text{ or } f(x) = 7x - 11.$$

 **Now Try Exercise 19.**

► Parallel Lines

Can we determine whether the graphs of two linear equations are parallel without graphing them? Let's look at three pairs of equations and their graphs.

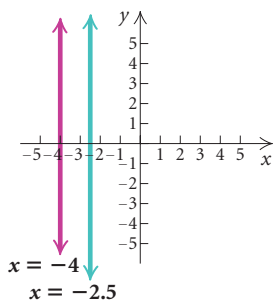

Parallel

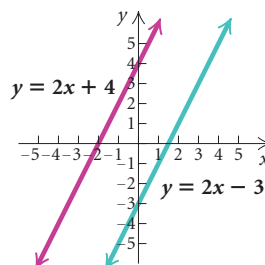

Parallel

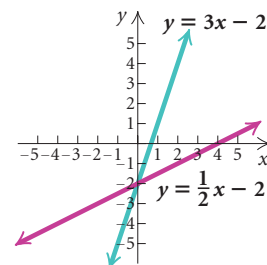

Not parallel

If two different lines, such as $x = -4$ and $x = -2.5$, are vertical, then they are parallel. Thus two equations such as $x = a_1$ and $x = a_2$, where $a_1 \neq a_2$, have graphs that are *parallel lines*. Two nonvertical lines, such as $y = 2x + 4$ and $y = 2x - 3$, or, in general, $y = mx + b_1$ and $y = mx + b_2$, where the slopes are the *same* and $b_1 \neq b_2$, also have graphs that are *parallel lines*.

Parallel Lines

Vertical lines are **parallel**. Nonvertical lines are **parallel** if and only if they have the same slope and different y -intercepts.

► Perpendicular Lines

Can we examine a pair of equations to determine whether their graphs are perpendicular without graphing the equations? Let's look at the following pairs of equations and their graphs.

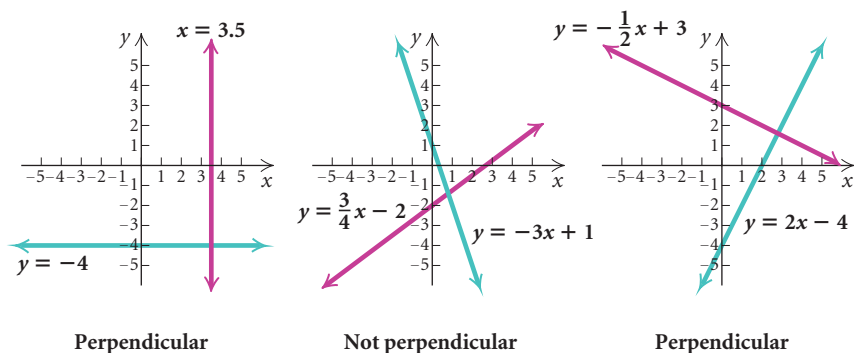

Perpendicular Lines

Two lines with slopes m_1 and m_2 are **perpendicular** if and only if the product of their slopes is -1 :

$$m_1 m_2 = -1.$$

Lines are also **perpendicular** if one is vertical ($x = a$) and the other is horizontal ($y = b$).

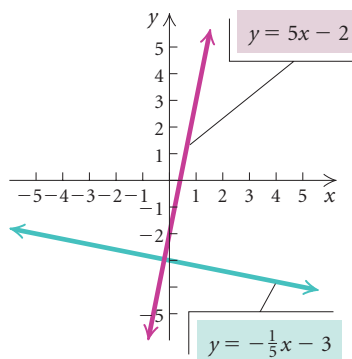

Figure 1

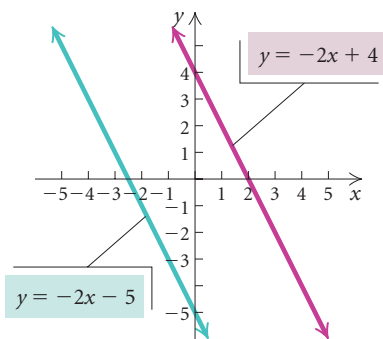

Figure 2

If a line has slope m_1 , the slope m_2 of a line perpendicular to it is $-1/m_1$. The slope of one line is the *opposite of the reciprocal* of the other:

$$m_2 = -\frac{1}{m_1}, \quad \text{or} \quad m_1 = -\frac{1}{m_2}.$$

EXAMPLE 4 Determine whether each of the following pairs of lines is parallel, perpendicular, or neither.

- $y + 2 = 5x$, $5y + x = -15$
- $2y + 4x = 8$, $5 + 2x = -y$
- $2x + 1 = y$, $y + 3x = 4$

Solution We use the slopes of the lines to determine whether the lines are parallel or perpendicular.

- a) We solve each equation for y :

$$y = 5x - 2, \quad y = -\frac{1}{5}x - 3.$$

The slopes are 5 and $-\frac{1}{5}$. Their product is -1 , so the lines are perpendicular. (See Fig. 1.)

- b) Solving each equation for y , we get

$$y = -2x + 4, \quad y = -2x - 5.$$

We see that $m_1 = -2$ and $m_2 = -2$. Since the slopes are the same and the y -intercepts, $(0, 4)$ and $(0, -5)$, are different, the lines are parallel. (See Fig. 2.)

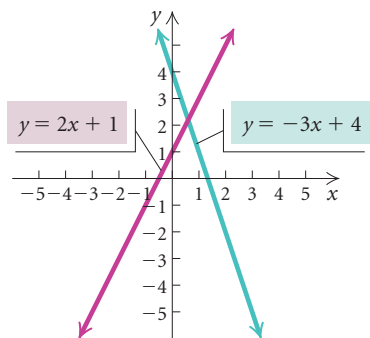

Figure 3

c) Solving each equation for y , we get

$$y = 2x + 1, \quad y = -3x + 4.$$

We see that $m_1 = 2$ and $m_2 = -3$. Since the slopes are not the same and their product is not -1 , it follows that the lines are neither parallel nor perpendicular. (See Fig. 3.)

➔ Now Try Exercises 35 and 39.

EXAMPLE 5 Write equations of the lines (a) parallel to and (b) perpendicular to the graph of the line $4y - x = 20$ and containing the point $(2, -3)$.

Solution We first solve $4y - x = 20$ for y to get $y = \frac{1}{4}x + 5$. We see that the slope of the given line is $\frac{1}{4}$.

a) The line parallel to the given line will have slope $\frac{1}{4}$. We use either the slope–intercept equation or the point–slope equation for a line with slope $\frac{1}{4}$ and containing the point $(2, -3)$. Here we use the point–slope equation:

$$\begin{aligned} y - y_1 &= m(x - x_1) \\ y - (-3) &= \frac{1}{4}(x - 2) \\ y + 3 &= \frac{1}{4}x - \frac{1}{2} \\ y &= \frac{1}{4}x - \frac{7}{2}. \end{aligned}$$

b) The slope of the perpendicular line is the opposite of the reciprocal of $\frac{1}{4}$, or -4 . Again we use the point–slope equation to write an equation for a line with slope -4 and containing the point $(2, -3)$:

$$\begin{aligned} y - y_1 &= m(x - x_1) \\ y - (-3) &= -4(x - 2) \\ y + 3 &= -4x + 8 \\ y &= -4x + 5. \end{aligned}$$

➔ Now Try Exercise 43.

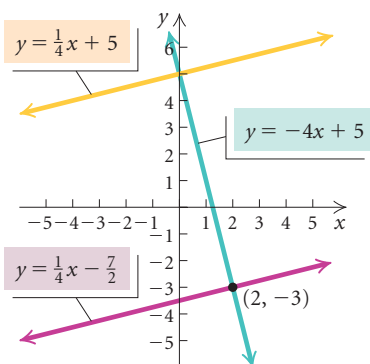

Summary of Terminology about Lines

TERMINOLOGY	MATHEMATICAL INTERPRETATION
Slope	$m = \frac{y_2 - y_1}{x_2 - x_1}$, or $\frac{y_1 - y_2}{x_1 - x_2}$
Slope–intercept equation	$y = mx + b$
Point–slope equation	$y - y_1 = m(x - x_1)$
Horizontal line	$y = b$
Vertical line	$x = a$
Parallel lines	$m_1 = m_2, b_1 \neq b_2$; also $x = a_1, x = a_2, a_1 \neq a_2$
Perpendicular lines	$m_1 m_2 = -1$, or $m_2 = -\frac{1}{m_1}$; also $x = a, y = b$

Creating a Mathematical Model

1. Recognize real-world problem.



2. Collect data.



3. Analyze data.



4. Construct model.



5. Test and refine model.



6. Explain and predict.

► Mathematical Models

When a real-world situation can be described in mathematical language, we have a **mathematical model**. For example, the natural numbers constitute a mathematical model for situations in which counting is essential. Situations in which algebra can be brought to bear often require the use of functions as models.

Mathematical models are abstracted from real-world situations. The mathematical model gives results that allow one to predict what will happen in that real-world situation. If the predictions are inaccurate or the results of experimentation do not conform to the model, the model must be changed or discarded.

Mathematical modeling can be an ongoing process. For example, finding a mathematical model that will provide an accurate prediction of population growth is not a simple problem. Any population model that one might devise would need to be reshaped as further information is acquired.

► Curve Fitting

We will develop and use many kinds of mathematical models in this text. In this chapter, we have used *linear* functions as models. Other types of functions, such as quadratic, cubic, and exponential functions, can also model data. These functions are *nonlinear*.

Quadratic function:
 $y = ax^2 + bx + c, a > 0$

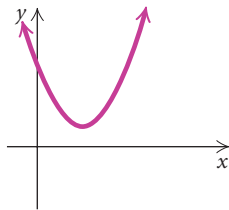

Cubic function:
 $y = ax^3 + bx^2 + cx + d, a > 0$

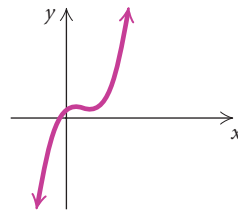

Exponential function:
 $y = ab^x, a, b > 0, b \neq 1$

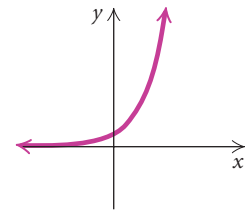

In general, we try to find a function that fits, as well as possible, observations (data), theoretical reasoning, and common sense. We call this **curve fitting**; it is one aspect of mathematical modeling.

Let's look at some data and related graphs, or **scatterplots**, and determine whether a linear function seems to fit the set of data.

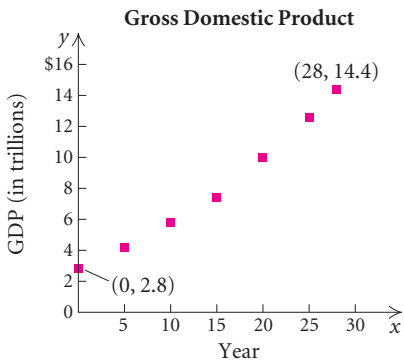
Year, x	Gross Domestic Product (GDP) (in trillions)	Scatterplot
1980, 0	\$ 2.8	 <p>Gross Domestic Product</p> <p>It appears that the data points can be represented or modeled by a linear function. The graph is linear.</p>
1985, 5	4.2	
1990, 10	5.8	
1995, 15	7.4	
2000, 20	10.0	
2005, 25	12.6	
2008, 28	14.4	

Sources: Bureau of Economic Analysis; U.S. Department of Commerce

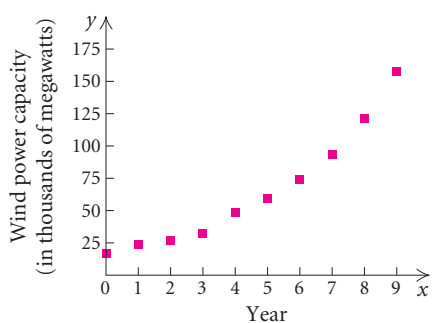
Year, x	Installed Wind Power Capacity (in megawatts)	Scatterplot
2000, 0	16,200	 <p>Wind power capacity</p> <p>It appears that the data points cannot be modeled accurately by a linear function. The graph is nonlinear.</p>
2001, 1	23,960	
2002, 2	26,520	
2003, 3	32,145	
2004, 4	48,780	
2005, 5	59,024	
2006, 6	74,151	
2007, 7	93,927	
2008, 8	121,188	
2009, 9	157,899	

Source: World Wind Energy Association, February 2010



Looking at the scatterplots, we see that the data on gross domestic product seem to be rising in a manner to suggest that a *linear function* might fit, although a “perfect” straight line cannot be drawn through the data points. A linear function does not seem to fit the data on wind power capacity.

EXAMPLE 6 *U.S. Gross Domestic Product.* The **gross domestic product** (GDP) of a country is the market value of final goods and services produced. Market value depends on the quantity of goods and services and their price. Model the data in the table above on the U.S. Gross Domestic Product with a linear function. Then estimate the GDP in 2012.

Solution We can choose any two of the data points to determine an equation. Note that the first coordinate is the number of years since 1980 and the second coordinate is the corresponding GDP in trillions of dollars. Let's use $(5, 4.2)$ and $(25, 12.6)$.

We first determine the slope of the line:

$$m = \frac{12.6 - 4.2}{25 - 5} = \frac{8.4}{20} = 0.42.$$

Then we substitute 0.42 for m and either of the points (5, 4.2) or (25, 12.6) for (x_1, y_1) in the point-slope equation. In this case, we use (5, 4.2). We get

$$y - y_1 = m(x - x_1) \quad \text{Point-slope equation}$$

$$y - 4.2 = 0.42(x - 5), \quad \text{Substituting}$$

which simplifies to

$$y = 0.42x + 2.1,$$

where x is the number of years after 1980 and y is in trillions of dollars.



Next, we estimate the GDP in 2012 by substituting 32 ($2012 - 1980 = 32$) for x in the model:

$$\begin{aligned} y &= 0.42x + 2.1 && \text{Model} \\ &= 0.42(32) + 2.1 && \text{Substituting} \\ &= 15.54. \end{aligned}$$

We estimate that the gross domestic product will be \$15.54 trillion in 2012.

Now Try Exercise 61.

In Example 6, if we were to use the data points (0, 2.8) and (28, 14.4), our model would be

$$y = 0.41x + 2.8,$$

and our estimate for the GDP in 2012 would be \$15.92 trillion, about \$0.38 trillion more than the estimate provided by the first model. This illustrates that a model and the estimates it produces are dependent on the data points used.

Models that consider all the data points, not just two, are generally better models. The model that best fits the data can be found using a graphing calculator and a procedure called **linear regression**. This procedure is explained in the following Technology Connection.

TECHNOLOGY CONNECTION

L1	L2	L3	2
0	2.8	---	---
5	4.2		
10	5.8		
15	7.4		
20	10		
25	12.6		
28	14.4		
Lz(7) = 14.4			

Figure 1

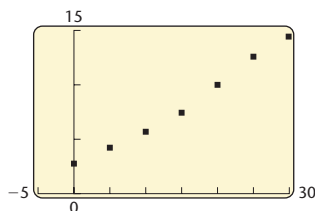

Figure 2

EDIT	CALC	TESTS
1:	1-Var Stats	
2:	2-Var Stats	
3:	Med-Med	
4:	LinReg(ax + b)	
5:	QuadReg	
6:	CubicReg	
7:	QuartReg	

Figure 3

LinReg
$y = ax + b$
$a = .4142539964$
$b = 2.075976909$
$r^2 = .9806576159$
$r = .9902815842$

Figure 4

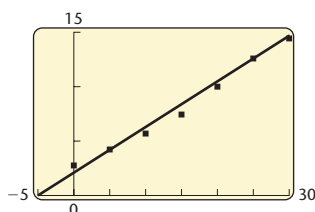

Figure 5

We now consider **linear regression**, a procedure that can be used to model a set of data using a linear function. Although discussion leading to a complete understanding of this method belongs in a statistics course, we present the procedure here because we can carry it out easily using technology. The graphing calculator gives us the powerful capability to find linear models and to make predictions using them.

Consider the data presented before Example 6 on the gross domestic product. We can fit a regression line of the form $y = mx + b$ to the data using the LINEAR REGRESSION feature on a graphing calculator.

First, we enter the data in lists on the calculator. We enter the values of the independent variable x in list L1 and the corresponding values of the dependent variable y in L2. (See Fig. 1.) The graphing calculator can then create a scatterplot of the data, as shown at left in Fig. 2.

When we select the LINEAR REGRESSION feature from the STAT CALC menu, we find the linear equation that best models the data. It is

$$y = .4142539964x + 2.075976909. \quad \text{Regression line}$$

(See Figs. 3 and 4.) We can then graph the regression line on the same graph as the scatterplot, as shown in Fig. 5.

To estimate the gross domestic product in 2012, we substitute 32 for x in the regression equation. Using this model, we see that the gross domestic product in 2012 is estimated to be about \$15.33 trillion. (See Fig. 6.)

Y1(32)	15.3321048
--------	------------

Figure 6

Note that \$15.33 trillion is closer to the value \$15.54 trillion found with data points (5, 4.2) and (25, 12.6) in Example 6 than to the value \$15.92 trillion found with the data points (0, 2.8) and (28, 14.4) following Example 6.

The Correlation Coefficient

On some graphing calculators with the DIAGNOSTIC feature turned on, a constant r between -1 and 1 , called the **coefficient of linear correlation**, appears with the equation of the regression line. Though we cannot develop a formula for calculating r in this text, keep in mind that it is used to describe the strength of the linear relationship between x and y . The closer $|r|$ is to 1 , the better the correlation. A positive value of r also indicates that the regression line has a positive slope, and a negative value of r indicates that the regression line has a negative slope. As shown in Fig. 4, for the data on gross domestic product just discussed,

$$r = 0.9902815842,$$

which indicates a good linear correlation.

1.4 Exercise Set

Find the slope and the y -intercept of the graph of the linear equation. Then write the equation of the line in slope–intercept form.

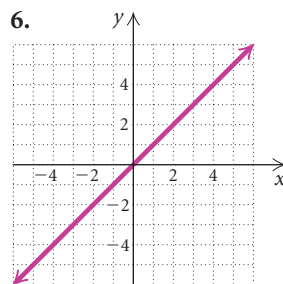
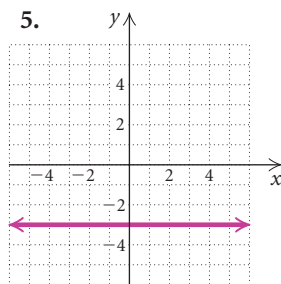
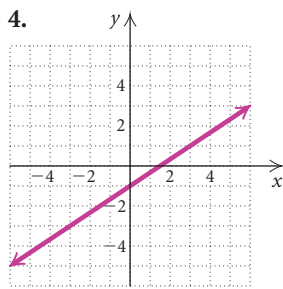
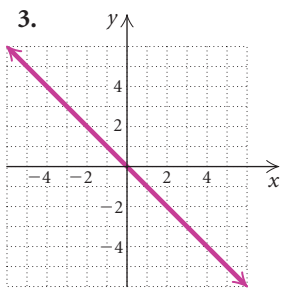
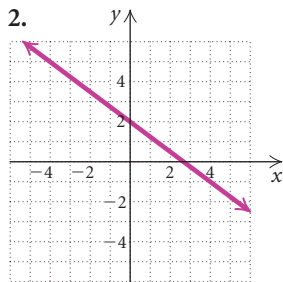
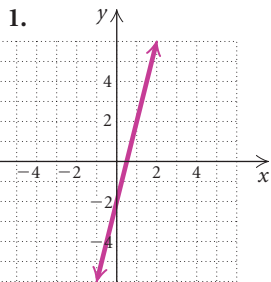

Write a slope–intercept equation for a line with the given characteristics.

- $m = \frac{2}{9}$, y -intercept $(0, 4)$
- $m = -\frac{3}{8}$, y -intercept $(0, 5)$
- $m = -4$, y -intercept $(0, -7)$
- $m = \frac{2}{7}$, y -intercept $(0, -6)$
- $m = -4.2$, y -intercept $(0, \frac{3}{4})$
- $m = -4$, y -intercept $(0, -\frac{3}{2})$
- $m = \frac{2}{9}$, passes through $(3, 7)$
- $m = -\frac{3}{8}$, passes through $(5, 6)$

- $m = 0$, passes through $(-2, 8)$
- $m = -2$, passes through $(-5, 1)$
- $m = -\frac{3}{5}$, passes through $(-4, -1)$
- $m = \frac{2}{3}$, passes through $(-4, -5)$
- Passes through $(-1, 5)$ and $(2, -4)$
- Passes through $(-3, \frac{1}{2})$ and $(1, \frac{1}{2})$
- Passes through $(7, 0)$ and $(-1, 4)$
- Passes through $(-3, 7)$ and $(-1, -5)$
- Passes through $(0, -6)$ and $(3, -4)$
- Passes through $(-5, 0)$ and $(0, \frac{4}{5})$
- Passes through $(-4, 7.3)$ and $(0, 7.3)$
- Passes through $(-13, -5)$ and $(0, 0)$

Write equations of the horizontal lines and the vertical lines that pass through the given point.

- $(0, -3)$
- $(-\frac{1}{4}, 7)$
- $(\frac{2}{11}, -1)$
- $(0.03, 0)$
- Find a linear function h given $h(1) = 4$ and $h(-2) = 13$. Then find $h(2)$.
- Find a linear function g given $g(-\frac{1}{4}) = -6$ and $g(2) = 3$. Then find $g(-3)$.
- Find a linear function f given $f(5) = 1$ and $f(-5) = -3$. Then find $f(0)$.
- Find a linear function h given $h(-3) = 3$ and $h(0) = 2$. Then find $h(-6)$.

Determine whether the pair of lines is parallel, perpendicular, or neither.

- $y = \frac{26}{3}x - 11$, $y = -\frac{3}{26}x - 11$
- $y = -3x + 1$, $y = -\frac{1}{3}x + 1$
- $y = \frac{2}{5}x - 4$, $y = -\frac{2}{5}x + 4$
- $y = \frac{3}{2}x - 8$, $y = 8 + 1.5x$
- $x + 2y = 5$, $2x + 4y = 8$
- $2x - 5y = -3$, $2x + 5y = 4$
- $y = 4x - 5$, $4y = 8 - x$
- $y = 7 - x$, $y = x + 3$

Write a slope–intercept equation for a line passing through the given point that is parallel to the given line. Then write a second equation for a line passing through the given point that is perpendicular to the given line.

43. $(3, 5)$, $y = \frac{2}{7}x + 1$
 44. $(-1, 6)$, $f(x) = 2x + 9$
 45. $(-7, 0)$, $y = -0.3x + 4.3$
 46. $(-4, -5)$, $2x + y = -4$
 47. $(3, -2)$, $3x + 4y = 5$
 48. $(8, -2)$, $y = 4.2(x - 3) + 1$
 49. $(3, -3)$, $x = -1$
 50. $(4, -5)$, $y = -1$

In Exercises 51–56, determine whether the statement is true or false.

51. The lines $x = -3$ and $y = 5$ are perpendicular.
 52. The lines $y = 2x - 3$ and $y = -2x - 3$ are perpendicular.
 53. The lines $y = \frac{2}{5}x + 4$ and $y = \frac{2}{5}x - 4$ are parallel.
 54. The intersection of the lines $y = 2$ and $x = -\frac{3}{4}$ is $(-\frac{3}{4}, 2)$.
 55. The lines $x = -1$ and $x = 1$ are perpendicular.
 56. The lines $2x + 3y = 4$ and $3x - 2y = 4$ are perpendicular.

In Exercises 57–60, determine whether a linear model might fit the data.

57.

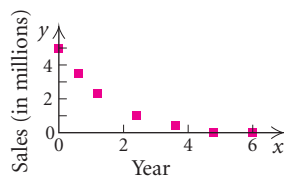

58.

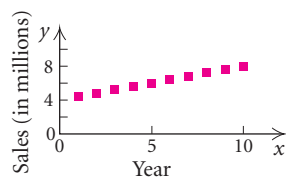

59.

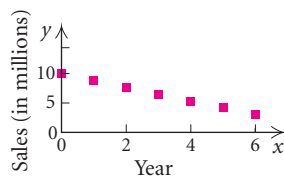

60.

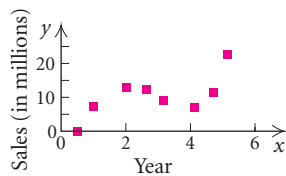

61. **Internet Use.** The table below illustrates the world growth in Internet use.

- a) Model the data with a linear function. Let the independent variable represent the number of years after 2001; that is, the data points are $(0, 494.1)$, $(3, 935.0)$, and so on. Answers may vary depending on the data points used.
 b) Using the function found in part (a), estimate the number of world Internet users in 2012 and in 2015.

Year, x	Number of World Internet Users, y (in millions)
2001, 0	494.1
2002, 1	679.8
2003, 2	790.1
2004, 3	935.0
2005, 4	1047.9
2006, 5	1217.0
2007, 6	1402.1
2008, 7	1542.5

Sources: International Telecommunication Union; ICT Indicators Database

62. **Cremations.** The table below illustrates the upward trend to choose cremation in America.

- a) Model the data with a linear function. Let the independent variable represent the number of years after 2005. Answers may vary depending on the data points used.
 b) Using the function found in part (a), estimate the percentage of deaths followed by cremation in 2011 and in 2016.

Year, x	Percentage of Deaths Followed by Cremation, y
2005, 0	32.2%
2006, 1	33.5
2007, 2	34.3
2008, 3	35.3
2009, 4	36.7 ¹

¹Projected

Source: Cremation Association of North America

63. **Ski Sales.** The table below illustrates how the sales of snow skis has declined in recent years. Model the data and use the model to estimate the sales of snow skis in 2012–2013. Answers may vary depending on the data points used.

Season, x	Snow Ski ¹ Sales, y (in thousands)
2004–2005, 0	539
2005–2006, 1	505
2006–2007, 2	475
2007–2008, 3	464
2008–2009, 4	414

¹Flat and systems

Source: SIA Retail Audit



64. **Median Age.** Data on the median age of the U.S. population in selected years are listed in the table below. Model the data with a linear function, estimate the median age in 1978, and predict the median age in 2020. Answers may vary depending on the data points used.

Year, x	Median Age, y
1950, 0	30.2
1960, 10	29.5
1970, 20	28.0
1980, 30	30.0
1990, 40	32.8
2000, 50	35.3
2008, 58	36.8

Source: U.S. Census Bureau

65. **Credit-Card Debt.** Model the data given in the table below with a linear function, and estimate the average credit-card debt per U.S. household in 2005 and in 2014. Answers may vary depending on the data points used.

Year, x	Credit-Card Debt per Household, y
1992, 0	\$ 3,803
1996, 4	6,912
2000, 8	8,308
2004, 12	9,577
2008, 16	10,691

Source: CardTrak.com



66. **Math Proficiency.** The percentage of eighth-graders from households with annual income greater than \$40,000 who are proficient in math is increasing. Model the data given in the table below with a linear function. Then estimate the percentage of eighth-graders from households earning more than \$40,000 per year who were proficient in math in 2008 and in 2013. Answers may vary depending on the data points used.

Year, x	Percentage of Eighth-Graders from Households with Annual Income Greater than \$40,000 Who Are Proficient in Math, y
2000, 0	34%
2003, 3	37
2005, 5	39
2007, 7	42
2009, 9	45

Source: Department of Education

Skill Maintenance

Find the slope of the line containing the given points.

67. $(5, 7)$ and $(5, -7)$

68. $(2, -8)$ and $(-5, -1)$

Find an equation for a circle satisfying the given conditions.

69. Center $(0, 3)$, diameter of length 5

70. Center $(-7, -1)$, radius of length $\frac{9}{5}$

Synthesis

71. Find k so that the line containing the points $(-3, k)$ and $(4, 8)$ is parallel to the line containing the points $(5, 3)$ and $(1, -6)$.

72. Find an equation of the line passing through the point $(4, 5)$ and perpendicular to the line passing through the points $(-1, 3)$ and $(2, 9)$.
73. **Road Grade.** Using the following figure, find the road grade and an equation giving the height y as a function of the horizontal distance x .

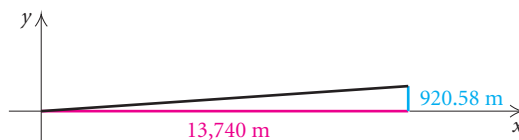
**Linear Equations, Functions, Zeros, and Applications****1.5**

- ▶ Solve linear equations.
- ▶ Solve applied problems using linear models.
- ▶ Find zeros of linear functions.

An **equation** is a statement that two expressions are equal. To **solve** an equation in one variable is to find all the values of the variable that make the equation true. Each of these numbers is a **solution** of the equation. The set of all solutions of an equation is its **solution set**. Some examples of **equations in one variable** are

$$2x + 3 = 5, \quad 3(x - 1) = 4x + 5, \quad x^2 - 3x + 2 = 0, \quad \text{and} \quad \frac{x - 3}{x + 4} = 1.$$

▶ Linear Equations

The first two equations above are *linear equations* in one variable. We define such equations as follows.

A **linear equation in one variable** is an equation that can be expressed in the form $mx + b = 0$, where m and b are real numbers and $m \neq 0$.

Note to the student and the instructor: We assume that students come to a College Algebra course with some equation-solving skills from their study of Intermediate Algebra. Thus a portion of the material in this section might be considered by some to be review in nature. We present this material here in order to use linear functions, with which students are familiar, to lay the groundwork for zeros of higher-order polynomial functions and their connection to solutions of equations and x -intercepts of graphs.

Equations that have the same solution set are **equivalent equations**. For example, $2x + 3 = 5$ and $x = 1$ are equivalent equations because 1 is the solution of each equation. On the other hand, $x^2 - 3x + 2 = 0$ and $x = 1$ are not equivalent equations because 1 and 2 are both solutions of $x^2 - 3x + 2 = 0$ but 2 is not a solution of $x = 1$.

To solve a linear equation, we find an equivalent equation in which the variable is isolated. The following principles allow us to solve linear equations.

Equation-Solving Principles

For any real numbers a , b , and c :

The Addition Principle: If $a = b$ is true, then $a + c = b + c$ is true.

The Multiplication Principle: If $a = b$ is true, then $ac = bc$ is true.

EXAMPLE 1 Solve: $\frac{3}{4}x - 1 = \frac{7}{5}$.

Solution When we have an equation that contains fractions, it is often convenient to multiply both sides of the equation by the least common denominator (LCD) of the fractions in order to clear the equation of fractions. We have

$$\frac{3}{4}x - 1 = \frac{7}{5}$$

The LCD is $4 \cdot 5$, or 20.

$$20\left(\frac{3}{4}x - 1\right) = 20 \cdot \frac{7}{5}$$

Multiplying by the LCD on both sides to clear fractions

$$20 \cdot \frac{3}{4}x - 20 \cdot 1 = 28$$

$$15x - 20 = 28$$

$$15x - 20 + 20 = 28 + 20$$

Using the addition principle to add 20 on both sides

$$15x = 48$$

$$\frac{15x}{15} = \frac{48}{15}$$

Using the multiplication principle to multiply by $\frac{1}{15}$, or divide by 15, on both sides

$$x = \frac{48}{15}$$

$$x = \frac{16}{5}$$

Simplifying. Note that $\frac{3}{4}x - 1 = \frac{7}{5}$ and $x = \frac{16}{5}$ are equivalent equations.

Check:

$$\frac{3}{4}x - 1 = \frac{7}{5}$$

$$\frac{3}{4} \cdot \frac{16}{5} - 1 \stackrel{?}{=} \frac{7}{5}$$

Substituting $\frac{16}{5}$ for x

$$\frac{12}{5} - \frac{5}{5}$$

$$\frac{7}{5} \quad \left| \quad \frac{7}{5} \right.$$

TRUE

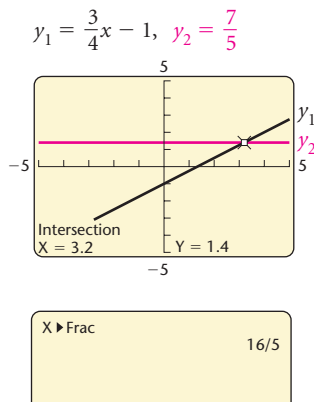
The solution is $\frac{16}{5}$.
 Now Try Exercise 15.

TECHNOLOGY CONNECTION

We can use the INTERSECT feature on a graphing calculator to solve equations. We call this the **Intersect method**. To use the Intersect method to solve the equation in Example 1, for instance, we graph $y_1 = \frac{3}{4}x - 1$ and $y_2 = \frac{7}{5}$. The value of x for which $y_1 = y_2$ is the solution of the equation $\frac{3}{4}x - 1 = \frac{7}{5}$. This value of x is the first coordinate of the point of intersection of the graphs of y_1 and y_2 . Using the INTERSECT feature, we find that the first coordinate of this point is 3.2. We can find fraction notation for the solution by using the \blacktriangleright FRAC feature. The solution is 3.2, or $\frac{16}{5}$.

EXAMPLE 2 Solve: $2(5 - 3x) = 8 - 3(x + 2)$.

Solution We have

$$2(5 - 3x) = 8 - 3(x + 2)$$

$$10 - 6x = 8 - 3x - 6$$

Using the distributive property

$$10 - 6x = 2 - 3x$$

Collecting like terms

$$10 - 6x + 6x = 2 - 3x + 6x$$

Using the addition principle to add $6x$ on both sides

$$10 = 2 + 3x$$

Using the addition principle to add -2 , or subtract 2, on both sides

$$10 - 2 = 2 + 3x - 2$$

$$8 = 3x$$

$$\frac{8}{3} = \frac{3x}{3}$$

Using the multiplication principle to multiply by $\frac{1}{3}$, or divide by 3, on both sides

$$\frac{8}{3} = x.$$

TECHNOLOGY CONNECTION

We can use the TABLE feature on a graphing calculator, set in ASK mode, to check the solutions of equations. In Example 2, for instance, let $y_1 = 2(5 - 3x)$ and $y_2 = 8 - 3(x + 2)$. When $\frac{8}{3}$ is entered for x , we see that $y_1 = y_2$, or $2(5 - 3x) = 8 - 3(x + 2)$. Thus, $\frac{8}{3}$ is the solution of the equation. (Note that the calculator converts $\frac{8}{3}$ to decimal notation in the table.)

X	Y1	Y2
2.6667	-6	-6
x =		

Check:

$$\begin{array}{r|l} 2(5 - 3x) = 8 - 3(x + 2) & \\ 2\left(5 - 3 \cdot \frac{8}{3}\right) & ? \quad 8 - 3\left(\frac{8}{3} + 2\right) \\ 2(5 - 8) & 8 - 3\left(\frac{14}{3}\right) \\ 2(-3) & 8 - 14 \\ -6 & -6 \end{array} \quad \begin{array}{l} \text{Substituting } \frac{8}{3} \text{ for } x \\ \\ \\ \\ \text{TRUE} \end{array}$$

The solution is $\frac{8}{3}$.

➔ Now Try Exercise 27.

Special Cases

Some equations have *no* solution.

EXAMPLE 3 Solve: $-24x + 7 = 17 - 24x$.

Solution We have

$$\begin{aligned} -24x + 7 &= 17 - 24x \\ 24x - 24x + 7 &= 24x + 17 - 24x && \text{Adding } 24x \\ 7 &= 17. && \text{We get a false equation.} \end{aligned}$$

No matter what number we substitute for x , we get a false sentence. Thus the equation has *no* solution.

➔ Now Try Exercise 11.

There are some equations for which *any* real number is a solution.

EXAMPLE 4 Solve: $3 - \frac{1}{3}x = -\frac{1}{3}x + 3$.

Solution We have

$$\begin{aligned} 3 - \frac{1}{3}x &= -\frac{1}{3}x + 3 \\ \frac{1}{3}x + 3 - \frac{1}{3}x &= \frac{1}{3}x - \frac{1}{3}x + 3 && \text{Adding } \frac{1}{3}x \\ 3 &= 3. && \text{We get a true equation.} \end{aligned}$$

Replacing x with any real number gives a true sentence. Thus *any* real number is a solution. This equation has *infinitely* many solutions. The solution set is the set of real numbers, $\{x|x \text{ is a real number}\}$, or $(-\infty, \infty)$.

➔ Now Try Exercise 3.

► Applications Using Linear Models

Mathematical techniques are used to answer questions arising from real-world situations. Linear equations and functions *model* many of these situations.

The following strategy is of great assistance in problem solving.

Five Steps for Problem Solving

1. **Familiarize** yourself with the problem situation. If the problem is presented in words, this means to read carefully. Some or all of the following can also be helpful.
 - a) Make a drawing, if it makes sense to do so.
 - b) Make a written list of the known facts and a list of what you wish to find out.
 - c) Assign variables to represent unknown quantities.
 - d) Organize the information in a chart or a table.
 - e) Find further information. Look up a formula, consult a reference book or an expert in the field, or do research on the Internet.
 - f) Guess or estimate the answer and check your guess or estimate.
2. **Translate** the problem situation to mathematical language or symbolism. For most of the problems you will encounter in algebra, this means to write one or more equations, but sometimes an inequality or some other mathematical symbolism may be appropriate.
3. **Carry out** some type of mathematical manipulation. Use your mathematical skills to find a possible solution. In algebra, this usually means to solve an equation, an inequality, or a system of equations or inequalities.
4. **Check** to see whether your possible solution actually fits the problem situation and is thus really a solution of the problem. Although you may have solved an equation, the solution(s) of the equation might not be solution(s) of the original problem.
5. **State** the answer clearly using a complete sentence.



EXAMPLE 5 *World Internet Users.* In 2008, there were about 1543 million world Internet users. This was 65% more than the number of Internet users in 2004. (*Source:* International Telecommunication Union, ICT Indicators Database) How many world Internet users were there in 2004?

Solution

1. **Familiarize.** Let's estimate that there were 980 million Internet users in 2004. Then the number of users in 2008, in millions, would be

$$\begin{aligned} 980 + 65\% \cdot 980 &= 1(980) + 0.65(980) \\ &= 1.65(980) \\ &= 1617. \end{aligned}$$

Since we know that there were actually 1543 million users in 2008, our estimate of 980 million is too high. Nevertheless, the calculations performed indicate how we can translate the problem to an equation. We let x = the number of world Internet users in 2004, in millions. Then $x + 65\%x$, or $1 \cdot x + 0.65 \cdot x$, or $1.65x$, is the number of users in 2008.

2. **Translate.** We translate to an equation:

$$\begin{array}{ccc} \text{World Internet users} & & \\ \text{in 2008} & \text{was} & \text{1543 million.} \\ \hline 1.65x & = & 1543 \end{array}$$

3. **Carry out.** We solve the equation, as follows:

$$\begin{aligned} 1.65x &= 1543 \\ x &= \frac{1543}{1.65} && \text{Dividing by 1.65 on both sides} \\ x &\approx 935. \end{aligned}$$

4. **Check.** Since 65% of 935 million is about 608 million and 935 million + 608 million = 1543 million, the answer checks.
 5. **State.** There were about 935 million world Internet users in 2004.

 **Now Try Exercise 33.**

EXAMPLE 6 Supermarkets. In 2008, the total number of supermarkets in California and Texas was 5898. There were 1608 more supermarkets in California than in Texas. (Source: The Nielsen Company) Find the number of supermarkets in California and in Texas.

Solution

1. **Familiarize.** The number of supermarkets in California is described in terms of the number in Texas, so we let x = the number of supermarkets in Texas. Then $x + 1608$ = the number of supermarkets in California.

2. **Translate.** We translate to an equation:

$$\begin{array}{ccc} \text{Number of supermarkets} & & \text{number of supermarkets} \\ \text{in California} & + & \text{in Texas} & \text{is} & 5898. \\ \hline x + 1608 & + & x & = & 5898 \end{array}$$

3. **Carry out.** We solve the equation, as follows:

$$\begin{aligned} x + 1608 + x &= 5898 \\ 2x + 1608 &= 5898 && \text{Collecting like terms} \\ 2x &= 4290 && \text{Subtracting 1608 on both sides} \\ x &= 2145. && \text{Dividing by 2 on both sides} \end{aligned}$$

If $x = 2145$, then $x + 1608 = 2145 + 1608 = 3753$.

4. **Check.** If there were 2145 supermarkets in Texas and 3753 in California, then the total number of supermarkets in Texas and California was $2145 + 3753$, or 5898. Also, 3753 is 1608 more than 2145. The answer checks.
 5. **State.** There were 3753 supermarkets in California and 2145 supermarkets in Texas in 2008.

 **Now Try Exercise 35.**

In some applications, we need to use a formula that describes the relationships among variables. When a situation involves distance, rate (also called speed or velocity), and time, for example, we use the following formula.



The Motion Formula

The distance d traveled by an object moving at rate r in time t is given by

$$d = r \cdot t.$$

EXAMPLE 7 Airplane Speed. America West Airlines' fleet includes Boeing 737-200's, each with a cruising speed of 500 mph, and Bombardier deHavilland Dash 8-200's, each with a cruising speed of 302 mph (Source: America West Airlines). Suppose that a Dash 8-200 takes off and travels at its cruising speed. One hour later, a 737-200 takes off and follows the same route, traveling at its cruising speed. How long will it take the 737-200 to overtake the Dash 8-200?

Solution

1. **Familiarize.** We make a drawing showing both the known and the unknown information. We let $t =$ the time, in hours, that the 737-200 travels before it overtakes the Dash 8-200. Since the Dash 8-200 takes off 1 hr before the 737, it will travel for $t + 1$ hr before being overtaken. The planes will have traveled the same distance, d , when one overtakes the other.

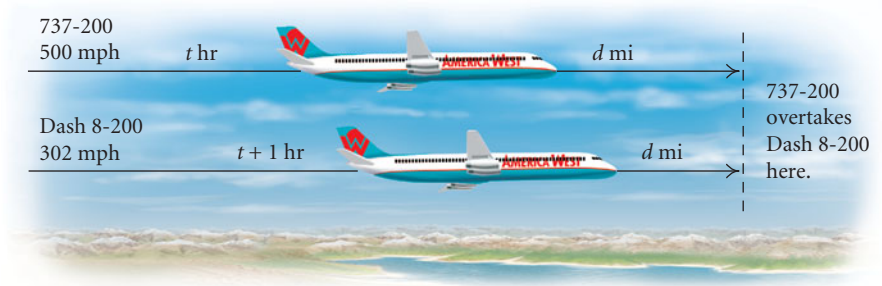

We can also organize the information in a table, as follows.

$$d = r \cdot t$$

	Distance	Rate	Time
737-200	d	500	t
Dash 8-200	d	302	$t + 1$

$$\rightarrow d = 500t$$

$$\rightarrow d = 302(t + 1)$$

2. **Translate.** Using the formula $d = rt$ in each row of the table, we get two expressions for d :

$$d = 500t \quad \text{and} \quad d = 302(t + 1).$$

Since the distances are the same, we have the following equation:

$$500t = 302(t + 1).$$

STUDY TIP

Prepare yourself for your homework assignment by reading the explanations of concepts and by following the step-by-step solutions of examples in the text. The time you spend preparing yourself will save you valuable time when you do your assignment.

3. Carry out. We solve the equation, as follows:

$$500t = 302(t + 1)$$

$$500t = 302t + 302$$

$$198t = 302$$

$$t \approx 1.53.$$

Using the distributive property

Subtracting $302t$ on both sides

Dividing by 198 on both sides and rounding to the nearest hundredth

4. Check. If the 737-200 travels for about 1.53 hr, then the Dash 8-200 travels for about $1.53 + 1$, or 2.53 hr. In 2.53 hr, the Dash 8-200 travels $302(2.53)$, or 764.06 mi, and in 1.53 hr, the 737-200 travels $500(1.53)$, or 765 mi. Since $764.06 \text{ mi} \approx 765 \text{ mi}$, the answer checks. (Remember that we rounded the value of t .)

5. State. About 1.53 hr after the 737-200 has taken off, it will overtake the Dash 8-200.

 Now Try Exercise 57.

For some applications, we need to use a formula to find the amount of interest earned by an investment or the amount of interest due on a loan.

The Simple-Interest Formula

The **simple interest** I on a principal of P dollars at interest rate r for t years is given by

$$I = Prt.$$

EXAMPLE 8 Student Loans. Jared's two student loans total \$12,000. One loan is at 5% simple interest and the other is at 8% simple interest. After 1 year, Jared owes \$750 in interest. What is the amount of each loan?

Solution

1. Familiarize. We let x = the amount borrowed at 5% interest. Then the remainder of the \$12,000, or $12,000 - x$, is borrowed at 8%. We organize the information in a table, keeping in mind the formula $I = Prt$.

	Amount Borrowed	Interest Rate	Time	Amount of Interest
5% Loan	x	5%, or 0.05	1 year	$x(0.05)(1)$, or $0.05x$
8% Loan	$12,000 - x$	8%, or 0.08	1 year	$(12,000 - x)(0.08)(1)$, or $0.08(12,000 - x)$
Total	12,000			750



2. **Translate.** The total amount of interest on the two loans is \$750. Thus we can translate to the following equation:

$$\begin{array}{ccccccc} \text{Interest on} & & \text{interest on} & & & & \\ \text{5\% loan} & \text{plus} & \text{8\% loan} & & \text{is} & & \$750. \\ \downarrow & & \downarrow & & \downarrow & & \downarrow \\ 0.05x & + & 0.08(12,000 - x) & = & 750 \end{array}$$

3. **Carry out.** We solve the equation, as follows:

$$\begin{aligned} 0.05x + 0.08(12,000 - x) &= 750 \\ 0.05x + 960 - 0.08x &= 750 \\ -0.03x + 960 &= 750 \\ -0.03x &= -210 \\ x &= 7000. \end{aligned}$$

Using the distributive property

Collecting like terms

Subtracting 960 on both sides

Dividing by -0.03 on both sides

If $x = 7000$, then $12,000 - x = 12,000 - 7000 = 5000$.

4. **Check.** The interest on \$7000 at 5% for 1 year is $\$7000(0.05)(1)$, or \$350. The interest on \$5000 at 8% for 1 year is $\$5000(0.08)(1)$, or \$400. Since $\$350 + \$400 = \$750$, the answer checks.
5. **State.** Jared borrowed \$7000 at 5% interest and \$5000 at 8% interest.

Now Try Exercise 63.

Sometimes we use formulas from geometry in solving applied problems. In the following example, we use the formula for the perimeter P of a rectangle with length l and width w : $P = 2l + 2w$.

EXAMPLE 9 Soccer Fields. The length of the largest regulation soccer field is 30 yd greater than the width, and the perimeter is 460 yd. Find the length and the width.

Solution

- Familiarize.** We first make a drawing. Since the length of the field is described in terms of the width, we let $w =$ the width, in yards. Then $w + 30 =$ the length, in yards.
- Translate.** We use the formula for the perimeter of a rectangle:

$$\begin{aligned} P &= 2l + 2w \\ 460 &= 2(w + 30) + 2w. \end{aligned}$$

Substituting 460 for P and $w + 30$ for l



3. **Carry out.** We solve the equation:

$$460 = 2(w + 30) + 2w$$

$$460 = 2w + 60 + 2w \quad \text{Using the distributive property}$$

$$460 = 4w + 60 \quad \text{Collecting like terms}$$

$$400 = 4w \quad \text{Subtracting 60 on both sides}$$

$$100 = w. \quad \text{Dividing by 4 on both sides}$$

If $w = 100$, then $w + 30 = 100 + 30 = 130$.

4. **Check.** The length, 130 yd, is 30 yd more than the width, 100 yd. Also,
 $2 \cdot 130 \text{ yd} + 2 \cdot 100 \text{ yd} = 260 \text{ yd} + 200 \text{ yd} = 460 \text{ yd}$.

The answer checks.

5. **State.** The length of the largest regulation soccer field is 130 yd, and the width is 100 yd. ➔ Now Try Exercise 53.

EXAMPLE 10 Cab Fare. Metro Taxi charges a \$1.25 pickup fee and \$2 per mile traveled. Cecilia's cab fare from the airport to her hotel is \$31.25. How many miles did she travel in the cab?

Solution

1. **Familiarize.** Let's guess that Cecilia traveled 12 mi in the cab. Then her fare would be

$$\$1.25 + \$2 \cdot 12 = \$1.25 + \$24 = \$25.25.$$

We see that our guess is low, but the calculation we did shows us how to translate the problem to an equation. We let m = the number of miles that Cecilia traveled in the cab.

2. **Translate.** We translate to an equation:

Pickup fee	plus	cost per mile	times	number of miles traveled	is	total charge.
1.25	+	2	·	m	=	31.25

3. **Carry out.** We solve the equation:

$$1.25 + 2 \cdot m = 31.25$$

$$2m = 30 \quad \text{Subtracting 1.25 on both sides}$$

$$m = 15. \quad \text{Dividing by 2 on both sides}$$

4. **Check.** If Cecilia travels 15 mi in the cab, the mileage charge is $\$2 \cdot 15$, or \$30. Then, with the \$1.25 pickup fee included, her total charge is $\$1.25 + \30 , or \$31.25. The answer checks.

5. **State.** Cecilia traveled 15 mi in the cab. ➔ Now Try Exercise 47.

► Zeros of Linear Functions

An input for which a function's output is 0 is called a **zero** of the function. We will restrict our attention in this section to zeros of linear functions. This allows us to become familiar with the concept of a zero, and it lays the groundwork for working with zeros of other types of functions in succeeding chapters.



Zeros of Functions

An input c of a function f is called a **zero** of the function if the output for the function is 0 when the input is c . That is, c is a zero of f if $f(c) = 0$.

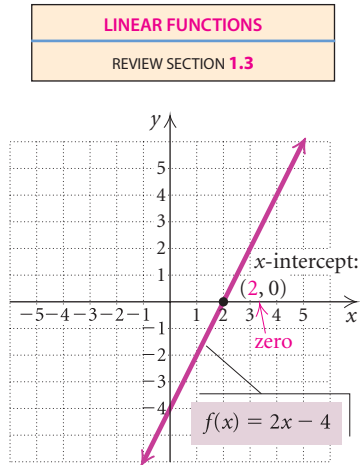

Recall that a linear function is given by $f(x) = mx + b$, where m and b are constants. For the linear function $f(x) = 2x - 4$, we have $f(2) = 2 \cdot 2 - 4 = 0$, so 2 is a **zero** of the function. In fact, 2 is the *only* zero of this function. In general, a **linear function $f(x) = mx + b$, with $m \neq 0$, has exactly one zero.**

Consider the graph of $f(x) = 2x - 4$, shown at left. We see from the graph that the zero, 2, is the first coordinate of the *x-intercept* of the graph. Thus when we find the zero of a linear function, we are also finding the first coordinate of the *x-intercept* of the function.

For every linear function $f(x) = mx + b$, there is an associated linear equation $mx + b = 0$. When we find the zero of a function $f(x) = mx + b$, we are also finding the solution of the equation $mx + b = 0$.

EXAMPLE 11 Find the zero of $f(x) = 5x - 9$.

Algebraic Solution

We find the value of x for which $f(x) = 0$:

$$5x - 9 = 0$$

Setting $f(x) = 0$

$$5x = 9$$

Adding 9 on both sides

$$x = \frac{9}{5}, \text{ or } 1.8.$$

Dividing by 5 on both sides

The zero is $\frac{9}{5}$, or 1.8. This means that $f(\frac{9}{5}) = 0$, or $f(1.8) = 0$. Note that the *zero* of the function $f(x) = 5x - 9$ is the *solution* of the equation $5x - 9 = 0$.



Visualizing the Solution

We graph $f(x) = 5x - 9$.

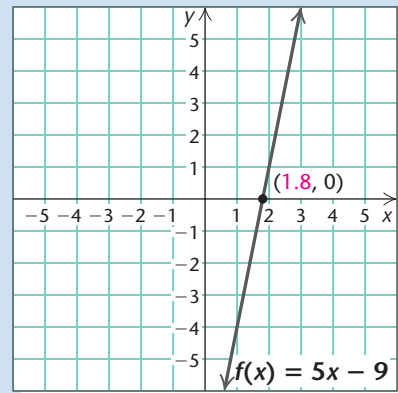

The *x-intercept* of the graph is $(\frac{9}{5}, 0)$, or $(1.8, 0)$. Thus, $\frac{9}{5}$, or 1.8, is the zero of the function.

➔ Now Try Exercise 73.

TECHNOLOGY CONNECTION

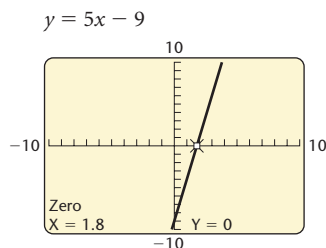

We can use the ZERO feature on a graphing calculator to find the zeros of a function $f(x)$ and to solve the corresponding equation $f(x) = 0$. We call this the **Zero method**. To use the Zero method in Example 11, for instance, we graph $y = 5x - 9$ and use the ZERO feature to find the coordinates of the x -intercept of the graph. Note that the x -intercept must appear in the window when the ZERO feature is used. We see that the zero of the function is 1.8.

CONNECTING THE CONCEPTS

Zeros, Solutions, and Intercepts

The zero of a linear function $f(x) = mx + b$, with $m \neq 0$, is the solution of the linear equation $mx + b = 0$ and is the first coordinate of the x -intercept of the graph of $f(x) = mx + b$. To find the zero of $f(x) = mx + b$, we solve $f(x) = 0$, or $mx + b = 0$.

FUNCTION

Linear Function

$$f(x) = 2x - 4, \text{ or}$$

$$y = 2x - 4$$

ZERO OF THE FUNCTION; SOLUTION OF THE EQUATION

To find the **zero** of $f(x)$, we solve $f(x) = 0$:

$$2x - 4 = 0$$

$$2x = 4$$

$$x = 2.$$

The **solution** of $2x - 4 = 0$ is **2**. This is the zero of the function $f(x) = 2x - 4$. That is, $f(2) = 0$.

ZERO OF THE FUNCTION; X-INTERCEPT OF THE GRAPH

The zero of $f(x)$ is the first coordinate of the **x -intercept** of the graph of $y = f(x)$.

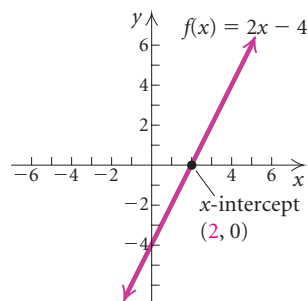

TECHNOLOGY CONNECTION

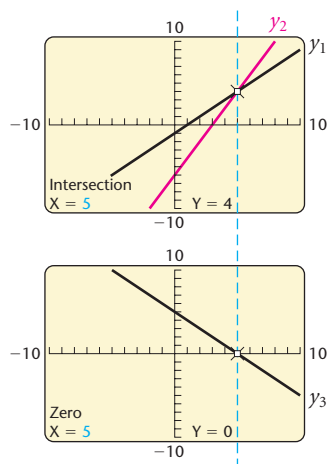

An equation such as $x - 1 = 2x - 6$ can be solved using the Intersect method by graphing $y_1 = x - 1$ and $y_2 = 2x - 6$ and using the INTERSECT feature to find the first coordinate of the point of intersection of the graphs. The equation can also be solved using the Zero method by writing it with 0 on one side of the equals sign and then using the ZERO feature.

Solve: $x - 1 = 2x - 6$.

The Intersect Method

Graph $y_1 = x - 1$ and $y_2 = 2x - 6$.

Point of intersection: $(5, 4)$

Solution: 5

The Zero Method

First add $-2x$ and 6 on both sides of the equation to get 0 on one side.

$$x - 1 = 2x - 6$$

$$x - 1 - 2x + 6 = 0$$

Graph $y_3 = x - 1 - 2x + 6$.

Zero: 5

Solution: 5

1.5

Exercise Set

Solve.

1. $4x + 5 = 21$
2. $2y - 1 = 3$
21. $3x - 5 = 2x + 1$
22. $4x + 3 = 2x - 7$
3. $23 - \frac{2}{5}x = -\frac{2}{5}x + 23$
4. $\frac{6}{5}y + 3 = \frac{3}{10}$
23. $4x - 5 = 7x - 2$
24. $5x + 1 = 9x - 7$
5. $4x + 3 = 0$
6. $3x - 16 = 0$
25. $5x - 2 + 3x = 2x + 6 - 4x$
7. $3 - x = 12$
8. $4 - x = -5$
26. $5x - 17 - 2x = 6x - 1 - x$
9. $3 - \frac{1}{4}x = \frac{3}{2}$
10. $10x - 3 = 8 + 10x$
27. $7(3x + 6) = 11 - (x + 2)$
11. $\frac{2}{11} - 4x = -4x + \frac{9}{11}$
12. $8 - \frac{2}{9}x = \frac{5}{6}$
28. $4(5y + 3) = 3(2y - 5)$
13. $8 = 5x - 3$
14. $9 = 4x - 8$
29. $3(x + 1) = 5 - 2(3x + 4)$
15. $\frac{2}{5}y - 2 = \frac{1}{3}$
16. $-x + 1 = 1 - x$
30. $4(3x + 2) - 7 = 3(x - 2)$
17. $y + 1 = 2y - 7$
18. $5 - 4x = x - 13$
31. $2(x - 4) = 3 - 5(2x + 1)$
19. $2x + 7 = x + 3$
20. $5x - 4 = 2x + 5$
32. $3(2x - 5) + 4 = 2(4x + 3)$

33. **Income Taxes.** In 2008, 36.3% of all tax filers paid no income taxes. This percentage is 10.7% more than the percentage of filers in 1999 who paid no income taxes. (Source: Tax Foundation) Find the percentage of tax filers in 1999 who paid no income taxes.
34. **Fuel Economy.** The Toyota Prius gets 44 miles per gallon (mpg) overall. The Hummer H2 gets 11 mpg less than one-half of the miles-per-gallon rate for the Toyota Prius. (Source: Consumer Reports, April 2010) Find the miles-per-gallon rate for the Hummer H2.
35. **Boat Speed.** BMW Oracle's USA trimaran boat, with a top speed of 45 knots, won the America's Cup in 2010. Its top speed is 5 knots more than 2.5 times the top speed of BMW Oracle's 2007 Cup monohull. (Source: BMW Oracle) Find the top speed of BMW Oracle's 2007 Cup entry.



36. **Salary Comparison.** The average salary of a landscape architect for the federal government is \$80,830 per year. This is about 38.5% higher than the yearly salary of a private-sector landscape architect. (Source: Bureau of Labor Statistics) Find the salary of a private-sector landscape architect.
37. **Ocean Depth.** The average depth of the Pacific Ocean is 14,040 ft, and its depth is 8890 ft less than the sum of the average depths of the Atlantic and Indian Oceans. The average depth of the Indian Ocean is 272 ft less than four-fifths of the average depth of the Atlantic Ocean. (Source: Time

Almanac, 2010) Find the average depth of the Indian Ocean.

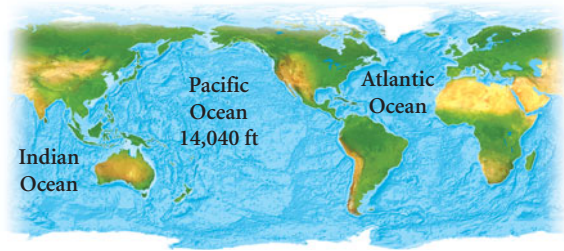

38. **Where the Textbook Dollar Goes.** Of each dollar spent on textbooks at college bookstores, 23.2 cents goes to the college store for profit, store operations, and personnel. On average, a college student at a four-year college spends \$940 per year for textbooks. (Source: College Board) How much of this expenditure goes to the college store?
39. **Vehicle Curb Weight.** The total curb weight of a Toyota Tundra truck, a Ford Mustang car, and a Smart For Two car is 11,150 lb. The weight of a Mustang is 5 lb less than the weight of two Smart For Two cars. The Tundra weighs 2135 lb more than the Mustang. (Source: Consumer Reports, April 2010) What is the curb weight of each vehicle?

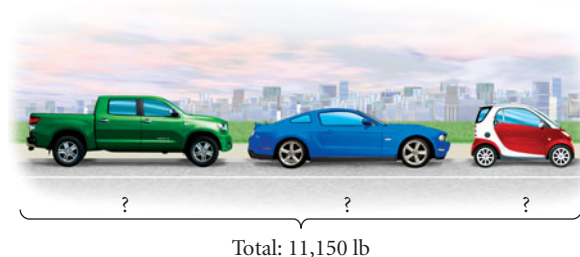

40. **Nutrition.** A slice of carrot cake from the popular restaurant The Cheesecake Factory contains 1560 calories. This is three-fourths of the average daily calorie requirement for many adults. (Source: The Center for Science in the Public Interest) Find the average daily calorie requirement for these adults.
41. **Television Viewers.** In a recent week, the television networks CBS, ABC, and NBC together averaged a total of 29.1 million viewers. CBS had 1.7 million more viewers than ABC, and NBC had 1.7 million fewer viewers than ABC. (Source: Nielsen Media Research) How many viewers did each network have?

42. **Nielsen Ratings.** Nielsen Media Research surveys TV-watching habits and provides a list of the 20 most-watched TV programs each week. Each rating point in the survey represents 1,102,000 households. One week “60 Minutes” had a rating of 11.0. How many households did this represent?
43. **Amount Borrowed.** Kendal borrowed money from her father at 5% simple interest to help pay her tuition at Wellington Community College. At the end of 1 year, she owed a total of \$1365 in principal and interest. How much did she borrow?
44. **Amount of an Investment.** Khalid makes an investment at 4% simple interest. At the end of 1 year, the total value of the investment is \$1560. How much was originally invested?
45. **Sales Commission.** Ryan, a consumer electronics salesperson, earns a base salary of \$1500 per month and a commission of 8% on the amount of sales he makes. One month Ryan received a paycheck for \$2284. Find the amount of his sales for the month.
46. **Commission vs. Salary.** Juliet has a choice between receiving a monthly salary of \$1800 from Furniture by Design or a base salary of \$1600 and a 4% commission on the amount of furniture she sells during the month. For what amount of sales will the two choices be equal?
47. **Hourly Wage.** Soledad worked 48 hr one week and earned a \$442 paycheck. She earns time and a half (1.5 times her regular hourly wage) for the number of hours she works in excess of 40. What is Soledad’s regular hourly wage?



48. **Cab Fare.** City Cabs charges a \$1.75 pickup fee and \$1.50 per mile traveled. Diego’s fare for a cross-town cab ride is \$19.75. How far did he travel in the cab?
49. **Angle Measure.** In triangle ABC , angle B is five times as large as angle A . The measure of angle C is 2° less than that of angle A . Find the measures of the angles. (*Hint:* The sum of the angle measures is 180° .)
50. **Angle Measure.** In triangle ABC , angle B is twice as large as angle A . Angle C measures 20° more than angle A . Find the measures of the angles.
51. **Test-Plot Dimensions.** Morgan’s Seeds has a rectangular test plot with a perimeter of 322 m. The length is 25 m more than the width. Find the dimensions of the plot.



52. **Garden Dimensions.** The children at Tiny Tots Day Care plant a rectangular vegetable garden with a perimeter of 39 m. The length is twice the width. Find the dimensions of the garden.
53. **Soccer-Field Dimensions.** The width of the soccer field recommended for players under the age of 12 is 35 yd less than the length. The perimeter of the field is 330 yd. (*Source:* U.S. Youth Soccer) Find the dimensions of the field.
54. **Poster Dimensions.** Marissa is designing a poster to promote the Talbot Street Art Fair. The width of the poster will be two-thirds of its height, and its perimeter will be 100 in. Find the dimensions of the poster.
55. **Water Weight.** Water accounts for 50% of a woman’s weight (*Source:* National Institute for Fitness and Sport). Kimiko weighs 135 lb. How much of her body weight is water?

56. **Water Weight.** Water accounts for 60% of a man's weight (*Source*: National Institute for Fitness and Sport). Emilio weighs 186 lb. How much of his body weight is water?
57. **Train Speeds.** A Central Railway freight train leaves a station and travels due north at a speed of 60 mph. One hour later, an Amtrak passenger train leaves the same station and travels due north on a parallel track at a speed of 80 mph. How long will it take the passenger train to overtake the freight train?
58. **Distance Traveled.** A private airplane leaves Midway Airport and flies due east at a speed of 180 km/h. Two hours later, a jet leaves Midway and flies due east at a speed of 900 km/h. How far from the airport will the jet overtake the private plane?
59. **Traveling Upstream.** A kayak moves at a rate of 12 mph in still water. If the river's current flows at a rate of 4 mph, how long does it take the boat to travel 36 mi upstream?



60. **Traveling Downstream.** Angelo's kayak travels 14 km/h in still water. If the river's current flows at a rate of 2 km/h, how long will it take him to travel 20 km downstream?
61. **Flying into a Headwind.** An airplane that travels 450 mph in still air encounters a 30-mph headwind. How long will it take the plane to travel 1050 mi into the wind?
62. **Flying with a Tailwind.** An airplane that can travel 375 mph in still air is flying with a 25-mph tailwind. How long will it take the plane to travel 700 mi with the wind?

63. **Investment Income.** Erica invested a total of \$5000, part at 3% simple interest and part at 4% simple interest. At the end of 1 year, the investments had earned \$176 interest. How much was invested at each rate?
64. **Student Loans.** Dimitri's two student loans total \$9000. One loan is at 5% simple interest and the other is at 6% simple interest. At the end of 1 year, Dimitri owes \$492 in interest. What is the amount of each loan?
65. **Networking Sites.** In November 2009, Facebook had 109.7 million visitors who visited the site at least once. This number of visitors was 39.7 million more than the total number of visitors to MySpace and Twitter. The number who visited Twitter was 31.8 million less than the number who visited MySpace. (*Source*: Nielsen) Find the number of visitors to MySpace and to Twitter.
66. **Calcium Content of Foods.** Together, one 8-oz serving of plain nonfat yogurt and one 1-oz serving of Swiss cheese contain 676 mg of calcium. The yogurt contains 4 mg more than twice the calcium in the cheese. (*Source*: U.S. Department of Agriculture) Find the calcium content of each food.
67. **NFL Stadium Elevation.** The elevations of the 31 NFL stadiums range from 3 ft at Giants Stadium in East Rutherford, New Jersey, to 5210 ft at Invesco Field at Mile High in Denver, Colorado. The elevation of Invesco Field at Mile High is 247 ft higher than seven times the elevation of Lucas Oil Stadium in Indianapolis, Indiana. What is the elevation of Lucas Oil Stadium?



68. **Public Libraries.** There is a total of 1525 public libraries in New York and Wisconsin. There are 151 more libraries in New York than twice the number in Wisconsin. (Source: Institute of Museums and Library Services) Find the number of public libraries in New York and in Wisconsin.



69. **Source of Drinking Water.** In the Dominican Republic, factory-bottled water is the primary source of drinking water for 67% of the urban population (Source: *National Geographic*, April 2010). In 2009, the population of the Dominican Republic was 9,650,054, of which 66.8% was urban. For how many in the urban population of the Dominican Republic was bottled water the primary source of drinking water?



70. **Volcanic Activity.** A volcano that is currently about one-half mile below the surface of the Pacific Ocean near the Big Island of Hawaii will eventually become a new Hawaiian island, Loihi. The volcano will break the surface of the ocean in about 50,000 years. (Source: U.S. Geological Survey) On average, how many inches does the volcano rise in a year?

Find the zero of the linear function.

- | | |
|--------------------------------|-----------------------|
| 71. $f(x) = x + 5$ | 72. $f(x) = 5x + 20$ |
| 73. $f(x) = -2x + 11$ | 74. $f(x) = 8 + x$ |
| 75. $f(x) = 16 - x$ | 76. $f(x) = -2x + 7$ |
| 77. $f(x) = x + 12$ | 78. $f(x) = 8x + 2$ |
| 79. $f(x) = -x + 6$ | 80. $f(x) = 4 + x$ |
| 81. $f(x) = 20 - x$ | 82. $f(x) = -3x + 13$ |
| 83. $f(x) = \frac{2}{5}x - 10$ | 84. $f(x) = 3x - 9$ |
| 85. $f(x) = -x + 15$ | 86. $f(x) = 4 - x$ |

In Exercises 87–92, use the given graph to find each of the following: (a) the x -intercept and (b) the zero of the function.

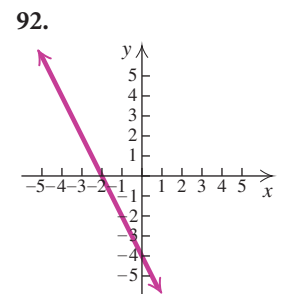
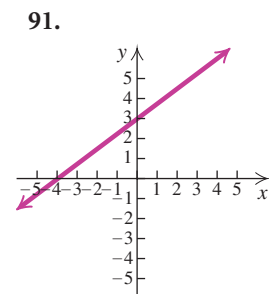
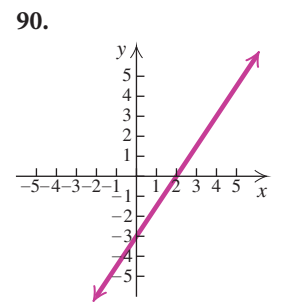
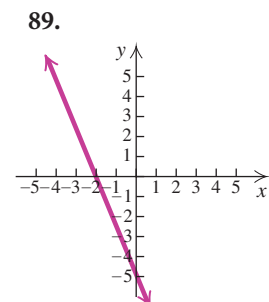
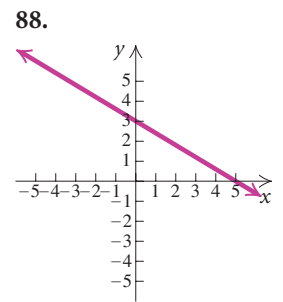
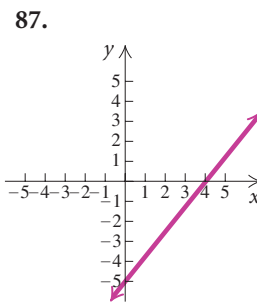

Skill Maintenance

93. Write a slope–intercept equation for the line containing the point $(-1, 4)$ and parallel to the line $3x + 4y = 7$.
94. Write an equation of the line containing the points $(-5, 4)$ and $(3, -2)$.
95. Find the distance between $(2, 2)$ and $(-3, -10)$.
96. Find the midpoint of the segment with endpoints $(-\frac{1}{2}, \frac{2}{5})$ and $(-\frac{3}{2}, \frac{3}{5})$.
97. Given that $f(x) = \frac{x}{x-3}$, find $f(-3)$, $f(0)$, and $f(3)$.
98. Find the slope and the y -intercept of the line with the equation $7x - y = \frac{1}{2}$.

Synthesis

State whether each of the following is a linear function.

99. $f(x) = 7 - \frac{3}{2}x$
100. $f(x) = \frac{3}{2x} + 5$
101. $f(x) = x^2 + 1$
102. $f(x) = \frac{3}{4}x - (2.4)^2$

Solve.

103. $2x - \{x - [3x - (6x + 5)]\} = 4x - 1$
104. $14 - 2[3 + 5(x - 1)] = 3\{x - 4[1 + 6(2 - x)]\}$

105. **Packaging and Price.** Dannon recently replaced its 8-oz cup of yogurt with a 6-oz cup and reduced the suggested retail price from 89 cents to 71 cents (Source: IRI). Was the price per ounce reduced by the same percent as the size of the cup? If not, find the price difference per ounce in terms of a percent.

106. **Packaging and Price.** Wisk laundry detergent recently replaced its 100-oz container with an 80-oz container and reduced the suggested retail price from \$6.99 to \$5.75 (Source: IRI). Was the price per ounce reduced by the same percent as the size of the container? If not, find the price difference per ounce in terms of a percent.

107. **Running vs. Walking.** A 150-lb person who runs at 6 mph for 1 hr burns about 720 calories. The same person, walking at 4 mph for 90 min, burns about 480 calories. (Source: FitSmart, USA Weekend, July 19–21, 2002) Suppose a 150-lb person runs at 6 mph for 75 min. How far would the person have to walk at 4 mph in order to burn the same number of calories used running?

108. **Bestsellers.** One week 10 copies of the novel *The Last Song* by Nicholas Sparks were sold for every 7.9 copies of David Baldacci's *Deliver Us from Evil* that were sold (Source: USA Today Best-Selling Books). If a total of 10,919 copies of the two books were sold, how many copies of each were sold?

Solving Linear Inequalities

1.6

- ▶ Solve linear inequalities.
- ▶ Solve compound inequalities.
- ▶ Solve applied problems using inequalities.

An **inequality** is a sentence with $<$, $>$, \leq , or \geq as its verb. An example is $3x - 5 < 6 - 2x$. To **solve** an inequality is to find all values of the variable that make the inequality true. Each of these numbers is a **solution** of the inequality, and the set of all such solutions is its **solution set**. Inequalities that have the same solution set are called **equivalent inequalities**.

► Linear Inequalities

The principles for solving inequalities are similar to those for solving equations.

Principles for Solving Inequalities

For any real numbers a , b , and c :

The Addition Principle for Inequalities:

If $a < b$ is true, then $a + c < b + c$ is true.

The Multiplication Principle for Inequalities:

a) If $a < b$ and $c > 0$ are true, then $ac < bc$ is true.

b) If $a < b$ and $c < 0$ are true, then $ac > bc$ is true.

(When both sides of an inequality are multiplied by a negative number, the inequality sign must be reversed.)

Similar statements hold for $a \leq b$.

First-degree inequalities with one variable, like those in Example 1 below, are **linear inequalities**.

EXAMPLE 1 Solve each of the following. Then graph the solution set.

a) $3x - 5 < 6 - 2x$

b) $13 - 7x \geq 10x - 4$

Solution

a) $3x - 5 < 6 - 2x$

$$5x - 5 < 6$$

Using the addition principle for inequalities; adding $2x$

$$5x < 11$$

Using the addition principle for inequalities; adding 5

$$x < \frac{11}{5}$$

Using the multiplication principle for inequalities; multiplying by $\frac{1}{5}$, or dividing by 5

Any number less than $\frac{11}{5}$ is a solution. The solution set is $\{x | x < \frac{11}{5}\}$, or $(-\infty, \frac{11}{5})$. The graph of the solution set is shown below.

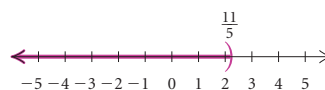

b) $13 - 7x \geq 10x - 4$

$$13 - 17x \geq -4$$

Subtracting $10x$

$$-17x \geq -17$$

Subtracting 13

$$x \leq 1$$

Dividing by -17 and reversing the inequality sign

The solution set is $\{x | x \leq 1\}$, or $(-\infty, 1]$. The graph of the solution set is shown below.



INTERVAL NOTATION

REVIEW SECTION R.1

TECHNOLOGY CONNECTION

To check Example 1(a), we can graph $y_1 = 3x - 5$ and $y_2 = 6 - 2x$. The graph shows that for $x < 2.2$, or $x < \frac{11}{5}$, the graph of y_1 lies below the graph of y_2 , or $y_1 < y_2$.

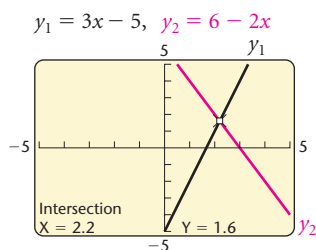

► Compound Inequalities

When two inequalities are joined by the word *and* or the word *or*, a **compound inequality** is formed. A compound inequality like

$$-3 < 2x + 5 \quad \text{and} \quad 2x + 5 \leq 7$$

is called a **conjunction**, because it uses the word *and*. The sentence $-3 < 2x + 5 \leq 7$ is an abbreviation for the preceding conjunction.

Compound inequalities can be solved using the addition and multiplication principles for inequalities.

EXAMPLE 2 Solve $-3 < 2x + 5 \leq 7$. Then graph the solution set.

Solution We have

$$-3 < 2x + 5 \leq 7$$

$$-8 < 2x \leq 2 \quad \text{Subtracting 5}$$

$$-4 < x \leq 1. \quad \text{Dividing by 2}$$

The solution set is $\{x \mid -4 < x \leq 1\}$, or $(-4, 1]$. The graph of the solution set is shown below.



➔ Now Try Exercise 17.

TECHNOLOGY CONNECTION

We can perform a partial check of the solution to Example 2 graphically using operations from the TEST menu and its LOGIC submenu on a graphing calculator. We graph $y_1 = (-3 < 2x + 5)$ and $(2x + 5 \leq 7)$ in DOT mode. The calculator graphs a segment 1 unit above the x -axis for the values of x for which this expression for y is true. Here the number 1 corresponds to “true.”

```
Plot1 Plot2 Plot3
:Y1= (-3<2X+5) and
(2X+5≤7)
:Y2=
:Y3=
:Y4=
:Y5=
:Y6=
```

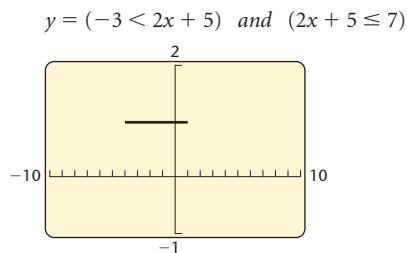

The segment extends from -4 to 1 , confirming that all x -values from -4 to 1 are in the solution set. The algebraic solution indicates that the endpoint 1 is also in the solution set.

TECHNOLOGY CONNECTION

To check the solution to Example 3, we graph $y_1 = 2x - 5$, $y_2 = -7$, and $y_3 = 1$. Note that for $\{x \mid x \leq -1 \text{ or } x > 3\}$, $y_1 \leq y_2 \text{ or } y_1 > y_3$.

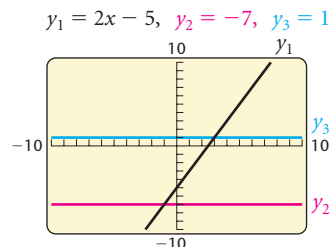

A compound inequality like $2x - 5 \leq -7$ or $2x - 5 > 1$ is called a **disjunction**, because it contains the word *or*. Unlike some conjunctions, it cannot be abbreviated; that is, it cannot be written without the word *or*.

EXAMPLE 3 Solve $2x - 5 \leq -7$ or $2x - 5 > 1$. Then graph the solution set.

Solution We have

$$2x - 5 \leq -7 \quad \text{or} \quad 2x - 5 > 1$$

$$2x \leq -2 \quad \text{or} \quad 2x > 6 \quad \text{Adding 5}$$

$$x \leq -1 \quad \text{or} \quad x > 3. \quad \text{Dividing by 2}$$

The solution set is $\{x \mid x \leq -1 \text{ or } x > 3\}$. We can also write the solution set using interval notation and the symbol \cup for the **union** or inclusion of both sets: $(-\infty, -1] \cup (3, \infty)$. The graph of the solution set is shown below.

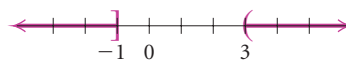

Now Try Exercise 29.



► An Application

EXAMPLE 4 *Income Plans.* For her house-painting job, Erica can be paid in one of two ways:

Plan A: \$250 plus \$10 per hour;

Plan B: \$20 per hour.

Suppose that a job takes n hours. For what values of n is plan B better for Erica?

Solution

1. **Familiarize.** Suppose that a job takes 20 hr. Then $n = 20$, and under plan A, Erica would earn $\$250 + \$10 \cdot 20$, or $\$250 + \200 , or $\$450$. Her earnings under plan B would be $\$20 \cdot 20$, or $\$400$. This shows that plan A is better for Erica if a job takes 20 hr. If a job takes 30 hr, then $n = 30$, and under plan A, Erica would earn $\$250 + \$10 \cdot 30$, or $\$250 + \300 , or $\$550$. Under plan B, she would earn $\$20 \cdot 30$, or $\$600$, so plan B is better in this case. To determine *all* values of n for which plan B is better for Erica, we solve an inequality. Our work in this step helps us write the inequality.

2. **Translate.** We translate to an inequality:

$$\underbrace{\text{Income from plan B}}_{20n} \quad \text{is greater than} \quad \underbrace{\text{income from plan A.}}_{250 + 10n}$$

$$20n > 250 + 10n$$

3. **Carry out.** We solve the inequality:

$$20n > 250 + 10n$$

$$10n > 250 \quad \text{Subtracting } 10n \text{ on both sides}$$

$$n > 25. \quad \text{Dividing by 10 on both sides}$$

4. **Check.** For $n = 25$, the income from plan A is $\$250 + \$10 \cdot 25$, or $\$250 + \250 , or $\$500$, and the income from plan B is $\$20 \cdot 25$, or $\$500$. This shows that for a job that takes 25 hr to complete, the income is the same under either plan. In the *Familiarize* step, we saw that plan B pays more for a 30-hr job. Since $30 > 25$, this provides a partial check of the result. We cannot check all values of n .
5. **State.** For values of n greater than 25 hr, plan B is better for Erica.

 Now Try Exercise 45.

1.6 Exercise Set

Solve and graph the solution set.

1. $4x - 3 > 2x + 7$
2. $8x + 1 \geq 5x - 5$
3. $x + 6 < 5x - 6$
4. $3 - x < 4x + 7$
5. $4 - 2x \leq 2x + 16$
6. $3x - 1 > 6x + 5$
7. $14 - 5y \leq 8y - 8$
8. $8x - 7 < 6x + 3$
9. $7x - 7 > 5x + 5$
10. $12 - 8y \geq 10y - 6$
11. $3x - 3 + 2x \geq 1 - 7x - 9$
12. $5y - 5 + y \leq 2 - 6y - 8$
13. $-\frac{3}{4}x \geq -\frac{5}{8} + \frac{2}{3}x$
14. $-\frac{5}{6}x \leq \frac{3}{4} + \frac{8}{3}x$
15. $4x(x - 2) < 2(2x - 1)(x - 3)$
16. $(x + 1)(x + 2) > x(x + 1)$

Solve and write interval notation for the solution set.

Then graph the solution set.

17. $-2 \leq x + 1 < 4$
18. $-3 < x + 2 \leq 5$
19. $5 \leq x - 3 \leq 7$
20. $-1 < x - 4 < 7$
21. $-3 \leq x + 4 \leq 3$
22. $-5 < x + 2 < 15$
23. $-2 < 2x + 1 < 5$
24. $-3 \leq 5x + 1 \leq 3$
25. $-4 \leq 6 - 2x < 4$
26. $-3 < 1 - 2x \leq 3$
27. $-5 < \frac{1}{2}(3x + 1) < 7$
28. $\frac{2}{3} \leq -\frac{4}{5}(x - 3) < 1$
29. $3x \leq -6$ or $x - 1 > 0$
30. $2x < 8$ or $x + 3 \geq 10$
31. $2x + 3 \leq -4$ or $2x + 3 \geq 4$
32. $3x - 1 < -5$ or $3x - 1 > 5$
33. $2x - 20 < -0.8$ or $2x - 20 > 0.8$

34. $5x + 11 \leq -4$ or $5x + 11 \geq 4$

35. $x + 14 \leq -\frac{1}{4}$ or $x + 14 \geq \frac{1}{4}$

36. $x - 9 < -\frac{1}{2}$ or $x - 9 > \frac{1}{2}$

37. **Cost of Business on the Internet.** The equation $y = 12.7x + 15.2$ estimates the amount that businesses will spend, in billions of dollars, on Internet software to conduct transactions via the Web, where x is the number of years after 2002 (Source: IDC). For what years will the spending be more than \$66 billion?

38. **Digital Hubs.** The equation $y = 5x + 5$ estimates the number of U.S. households, in millions, expected to install devices that receive and manage broadband TV and Internet content to the home, where x is the number of years after 2002 (Source: Forrester Research). For what years will there be at least 20 million homes with these devices?

39. **Moving Costs.** Acme Movers charges \$100 plus \$30 per hour to move a household across town. Hank's Movers charges \$55 per hour. For what lengths of time does it cost less to hire Hank's Movers?



40. **Investment Income.** Gina plans to invest \$12,000, part at 4% simple interest and the rest at 6% simple interest. What is the most that she can invest at 4% and still be guaranteed at least \$650 in interest per year?

41. **Investment Income.** Kyle plans to invest \$7500, part at 4% simple interest and the rest at 5% simple interest. What is the most that he can invest at 4% and still be guaranteed at least \$325 in interest per year?

42. **Investment Income.** A university invests \$600,000 at simple interest, part at 6%, half that amount at 4.5%, and the rest at 3.5%. What is the most that the university can invest at 3.5% and be guaranteed \$24,600 in interest per year?

43. **Investment Income.** A foundation invests \$50,000 at simple interest, part at 7%, twice that amount at 4%, and the rest at 5.5%. What is the most that the foundation can invest at 4% and be guaranteed \$2660 in interest per year?

44. **Income Plans.** Karen can be paid in one of two ways for selling insurance policies:

Plan A: A salary of \$750 per month, plus a commission of 10% of sales;

Plan B: A salary of \$1000 per month, plus a commission of 8% of sales in excess of \$2000.

For what amount of monthly sales is plan A better than plan B if we can assume that sales are always more than \$2000?

45. **Income Plans.** Curt can be paid in one of two ways for the furniture he sells:

Plan A: A salary of \$900 per month, plus a commission of 10% of sales;

Plan B: A salary of \$1200 per month, plus a commission of 15% of sales in excess of \$8000.

For what amount of monthly sales is plan B better than plan A if we can assume that Curt's sales are always more than \$8000?

46. **Income Plans.** Jeanette can be paid in one of two ways for painting a house:

Plan A: \$200 plus \$12 per hour;

Plan B: \$20 per hour.

Suppose a job takes n hours to complete. For what values of n is plan A better for Jeanette?

Skill Maintenance

In each of Exercises 47–50, fill in the blank(s) with the correct term(s). Some of the given choices will not be used; others will be used more than once.

constant	domain
function	distance formula
any	exactly one
midpoint formula	identity
y -intercept	x -intercept
range	

47. A(n) _____ is a correspondence between a first set, called the _____, and a second set, called the _____, such that each member of the _____ corresponds to _____ member of the _____.

48. The _____ is $\left(\frac{x_1 + x_2}{2}, \frac{y_1 + y_2}{2}\right)$.

49. A(n) _____ is a point $(a, 0)$.

50. A function f is a linear function if it can be written as $f(x) = mx + b$, where m and b are constants. If $m = 0$, the function is a(n) _____ function $f(x) = b$. If $m = 1$ and $b = 0$, the function is the _____ function $f(x) = x$.

Synthesis

Solve.

51. $2x \leq 5 - 7x < 7 + x$

52. $x \leq 3x - 2 \leq 2 - x$

53. $3y < 4 - 5y < 5 + 3y$

54. $y - 10 < 5y + 6 \leq y + 10$

Chapter 1 Summary and Review

STUDY GUIDE

KEY TERMS AND CONCEPTS

EXAMPLES

SECTION 1.1: INTRODUCTION TO GRAPHING

Graphing Equations

To **graph** an equation is to make a drawing that represents the solutions of that equation. We can graph an equation by selecting values for one variable and finding the corresponding values for the other variable. We list the solutions (ordered pairs) in a table, plot the points, and draw the graph.

Intercepts

An **x-intercept** is a point $(a, 0)$.

To find a , let $y = 0$ and solve for x .

A **y-intercept** is a point $(0, b)$.

To find b , let $x = 0$ and solve for y .

We can graph a straight line by plotting the intercepts and drawing the line containing them.

Distance Formula

The **distance** d between any two points (x_1, y_1) and (x_2, y_2) is given by

$$d = \sqrt{(x_2 - x_1)^2 + (y_2 - y_1)^2}.$$

Midpoint Formula

If the endpoints of a segment are (x_1, y_1) and (x_2, y_2) , then the coordinates of the **midpoint** of the segment are

$$\left(\frac{x_1 + x_2}{2}, \frac{y_1 + y_2}{2} \right).$$

Graph: $y = 4 - x^2$.

x	$y = 4 - x^2$	(x, y)
0	4	$(0, 4)$
-1	3	$(-1, 3)$
1	3	$(1, 3)$
-2	0	$(-2, 0)$
2	0	$(2, 0)$

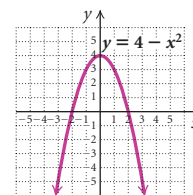

Graph using intercepts: $2x - y = 4$.

Let $y = 0$:

$$2x - 0 = 4$$

$$2x = 4$$

$$x = 2.$$

The x-intercept is $(2, 0)$.

Let $x = 0$:

$$2 \cdot 0 - y = 4$$

$$-y = 4$$

$$y = -4.$$

The y-intercept is $(0, -4)$.

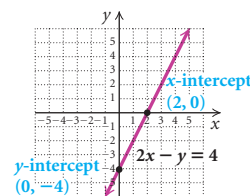

Find the distance between $(-5, 7)$ and $(2, -3)$.

$$\begin{aligned} d &= \sqrt{[2 - (-5)]^2 + (-3 - 7)^2} \\ &= \sqrt{7^2 + (-10)^2} \\ &= \sqrt{49 + 100} \\ &= \sqrt{149} \approx 12.2 \end{aligned}$$

Find the midpoint of the segment whose endpoints are $(-10, 4)$ and $(3, 8)$.

$$\begin{aligned} \left(\frac{x_1 + x_2}{2}, \frac{y_1 + y_2}{2} \right) &= \left(\frac{-10 + 3}{2}, \frac{4 + 8}{2} \right) \\ &= \left(-\frac{7}{2}, 6 \right) \end{aligned}$$

Circles

The **standard form** of the equation of a circle with center (h, k) and radius r is

$$(x - h)^2 + (y - k)^2 = r^2.$$

Find an equation of a circle with center $(1, -6)$ and radius 8.

$$\begin{aligned}(x - h)^2 + (y - k)^2 &= r^2 \\ (x - 1)^2 + [y - (-6)]^2 &= 8^2 \\ (x - 1)^2 + (y + 6)^2 &= 64\end{aligned}$$

Given the circle

$$(x + 9)^2 + (y - 2)^2 = 121,$$

determine the center and the radius.

Writing in standard form, we have

$$[x - (-9)]^2 + (y - 2)^2 = 11^2.$$

The center is $(-9, 2)$, and the radius is 11.

SECTION 1.2: FUNCTIONS AND GRAPHS**Functions**

A **function** is a correspondence between a first set, called the **domain**, and a second set, called the **range**, such that each member of the domain corresponds to *exactly one* member of the range.

Consider the function given by

$$\begin{aligned}g(x) &= |x| - 1. \\ g(-3) &= |-3| - 1 \\ &= 3 - 1 \\ &= 2\end{aligned}$$

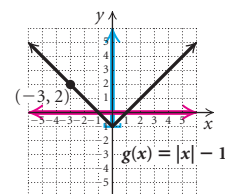

For the input -3 , the output is 2 :

$$f(-3) = 2.$$

The point $(-3, 2)$ is on the graph.

Domain: Set of all inputs = \mathbb{R} , or $(-\infty, \infty)$.

Range: Set of all outputs: $\{y \mid y \geq -1\}$, or $[-1, \infty)$.

The Vertical-Line Test

If it is possible for a vertical line to cross a graph more than once, then the graph is *not* the graph of a function.

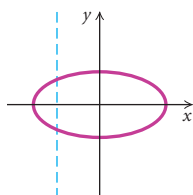

This is *not* the graph of a function because a vertical line can cross it more than once, as shown.

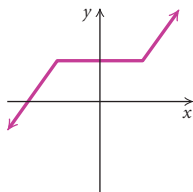

This is the graph of a function because no vertical line can cross it more than once.

Domain

When a function f whose inputs and outputs are real numbers is given by a formula, the **domain** is the set of all inputs for which the expression is defined as a real number.

Find the domain of the function given by

$$h(x) = \frac{(x - 1)}{(x + 5)(x - 10)}.$$

Division by 0 is not defined. Since $x + 5 = 0$ when $x = -5$ and $x - 10 = 0$ when $x = 10$, the domain of h is

$$\begin{aligned}\{x \mid x \text{ is a real number and } x \neq -5 \text{ and } x \neq 10\}, \\ \text{or } (-\infty, -5) \cup (-5, 10) \cup (10, \infty).\end{aligned}$$

SECTION 1.3: LINEAR FUNCTIONS, SLOPE, AND APPLICATIONS

Slope

$$m = \frac{\text{rise}}{\text{run}} = \frac{y_2 - y_1}{x_2 - x_1} = \frac{y_1 - y_2}{x_1 - x_2}$$

Slope can also be considered as an **average rate of change**. To find the average rate of change between two data points on a graph, determine the slope of the line that passes through the points.

Slope–Intercept Form of an Equation

$$f(x) = mx + b$$

The slope of the line is m .

The y -intercept of the line is $(0, b)$.

To graph an equation written in slope–intercept form, plot the y -intercept and use the slope to find another point. Then draw the line.

Horizontal Lines

The graph of $y = b$, or $f(x) = b$, is a horizontal line with y -intercept $(0, b)$. The slope of a horizontal line is 0.

Vertical Lines

The graph of $x = a$ is a vertical line with x -intercept $(a, 0)$. The slope of a vertical line is *not* defined.

The slope of the line containing the points $(3, -10)$ and $(-2, 6)$ is

$$\begin{aligned} m &= \frac{y_2 - y_1}{x_2 - x_1} = \frac{6 - (-10)}{-2 - 3} \\ &= \frac{16}{-5} = -\frac{16}{5}. \end{aligned}$$

In 2000, the population of Flint, Michigan, was 124,943. By 2008, the population had decreased to 112,900. Find the average rate of change in population from 2000 to 2008.

$$\begin{aligned} \text{Average rate of change} = m &= \frac{112,900 - 124,943}{2008 - 2000} \\ &= \frac{-12,043}{8} \approx -1505 \end{aligned}$$

The average rate of change in population over the 8-year period was a decrease of 1505 people per year.

Determine the slope and the y -intercept of the line given by $5x - 7y = 14$.

We first find the slope–intercept form:

$$\begin{aligned} 5x - 7y &= 14 \\ -7y &= -5x + 14 && \text{Adding } -5x \\ y &= \frac{5}{7}x - 2. && \text{Multiplying by } -\frac{1}{7} \end{aligned}$$

The slope is $\frac{5}{7}$, and the y -intercept is $(0, -2)$.

Graph: $f(x) = -\frac{2}{3}x + 4$.

We plot the y -intercept, $(0, 4)$. Think of the slope as $-\frac{2}{3}$. From the y -intercept, we find another point by moving 2 units down and 3 units to the right to the point $(3, 2)$. We then draw the graph.

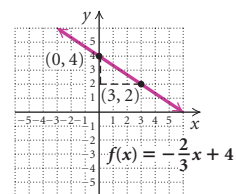

Graph $y = -4$ and determine its slope.

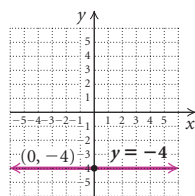

The slope is 0.

Graph $x = 3$ and determine its slope.

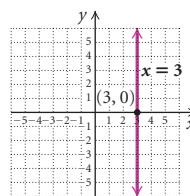

The slope is not defined.

SECTION 1.4: EQUATIONS OF LINES AND MODELING

Slope-Intercept Form of an Equation

$$y = mx + b, \text{ or } f(x) = mx + b$$

The slope of the line is m .

The y -intercept of the line is $(0, b)$.

Point-Slope Form of an Equation

$$y - y_1 = m(x - x_1)$$

The slope of the line is m .

The line passes through (x_1, y_1) .

Parallel Lines

Vertical lines are parallel. Nonvertical lines are **parallel** if and only if they have the same slope and different y -intercepts.

Write the slope-intercept equation for a line with slope $-\frac{2}{9}$ and y -intercept $(0, 4)$.

$$y = mx + b \quad \text{Using the slope-intercept form}$$

$$y = -\frac{2}{9}x + 4 \quad \text{Substituting } -\frac{2}{9} \text{ for } m \text{ and } 4 \text{ for } b$$

Write the slope-intercept equation for a line that passes through $(-5, 7)$ and $(3, -9)$.

We first determine the slope:

$$m = \frac{-9 - 7}{3 - (-5)} = \frac{-16}{8} = -2.$$

Using the slope-intercept form: We substitute -2 for m and either $(-5, 7)$ or $(3, -9)$ for (x, y) and solve for b :

$$y = mx + b$$

$$7 = -2 \cdot (-5) + b \quad \text{Using } (-5, 7)$$

$$7 = 10 + b$$

$$-3 = b.$$

The slope-intercept equation is $y = -2x - 3$.

Using the point-slope equation: We substitute -2 for m and either $(-5, 7)$ or $(3, -9)$ for (x_1, y_1) :

$$y - y_1 = m(x - x_1)$$

$$y - (-9) = -2(x - 3) \quad \text{Using } (3, -9)$$

$$y + 9 = -2x + 6$$

$$y = -2x - 3.$$

The slope-intercept equation is $y = -2x - 3$.

Write the slope-intercept equation for a line passing through $(-3, 1)$ that is parallel to the line $y = \frac{2}{3}x + 5$.

The slope of $y = \frac{2}{3}x + 5$ is $\frac{2}{3}$, so the slope of a line parallel to this line is also $\frac{2}{3}$. We use either the slope-intercept equation or the point-slope equation for a line with slope $\frac{2}{3}$ and containing the point $(-3, 1)$. Here we use the point-slope equation and substitute $\frac{2}{3}$ for m , -3 for x_1 , and 1 for y_1 .

$$y - y_1 = m(x - x_1)$$

$$y - 1 = \frac{2}{3}[x - (-3)]$$

$$y - 1 = \frac{2}{3}x + 2$$

$$y = \frac{2}{3}x + 3 \quad \text{Slope-intercept form}$$

Perpendicular Lines

Two lines are **perpendicular** if and only if the product of their slopes is -1 or if one line is vertical ($x = a$) and the other is horizontal ($y = b$).

Write the slope–intercept equation for a line that passes through $(-3, 1)$ and is perpendicular to the line $y = \frac{2}{3}x + 5$.

The slope of $y = \frac{2}{3}x + 5$ is $\frac{2}{3}$, so the slope of a line perpendicular to this line is the opposite of the reciprocal of $\frac{2}{3}$, or $-\frac{3}{2}$. Here we use the point–slope equation and substitute $-\frac{3}{2}$ for m , -3 for x_1 , and 1 for y_1 .

$$y - y_1 = m(x - x_1)$$

$$y - 1 = -\frac{3}{2}[x - (-3)]$$

$$y - 1 = -\frac{3}{2}(x + 3)$$

$$y - 1 = -\frac{3}{2}x - \frac{9}{2}$$

$$y = -\frac{3}{2}x - \frac{7}{2}$$

SECTION 1.5: LINEAR EQUATIONS, FUNCTIONS, ZEROS, AND APPLICATIONS**Equation–Solving Principles**

Addition Principle: If $a = b$ is true, then $a + c = b + c$ is true.

Multiplication Principle: If $a = b$ is true, then $ac = bc$ is true.

Solve: $2(3x - 7) = 15 - (x + 1)$.

$$2(3x - 7) = 15 - (x + 1)$$

$$6x - 14 = 15 - x - 1$$

Using the distributive property

$$6x - 14 = 14 - x$$

Collecting like terms

$$6x - 14 + x = 14 - x + x$$

Adding x on both sides

$$7x - 14 = 14$$

$$7x - 14 + 14 = 14 + 14$$

Adding 14 on both sides

$$7x = 28$$

$$\frac{1}{7} \cdot 7x = \frac{1}{7} \cdot 28$$

Multiplying by $\frac{1}{7}$ on both sides

$$x = 4$$

Check:

$2(3x - 7)$	$=$	$15 - (x + 1)$
$2(3 \cdot 4 - 7)$	$?$	$15 - (4 + 1)$
$2(12 - 7)$	$ $	$15 - 5$
$2 \cdot 5$	$ $	10
10	$ $	10

TRUE

The solution is 4.

Special Cases

Some equations have *no* solution.

Solve: $2 + 17x = 17x - 9$.

$$2 + 17x = 17x - 9$$

$$2 + 17x - 17x = 17x - 9 - 17x$$

Subtracting $17x$ on both sides

$$2 = -9$$

False equation

We get a false equation; thus the equation has *no* solution.

(Continued)

There are some equations for which *any* real number is a solution.

$$\text{Solve: } 5 - \frac{1}{2}x = -\frac{1}{2}x + 5.$$

$$5 - \frac{1}{2}x = -\frac{1}{2}x + 5$$

$$5 - \frac{1}{2}x + \frac{1}{2}x = -\frac{1}{2}x + 5 + \frac{1}{2}x$$

Adding $\frac{1}{2}x$ on both sides

$$5 = 5$$

True equation

We get a true equation. Thus any real number is a solution. The solution set is

$$\{x \mid x \text{ is a real number}\}, \text{ or } (-\infty, \infty).$$

Zeros of Functions

An input c of a function f is called a zero of the function if the output for the function is 0 when the input is c . That is,

$$c \text{ is a zero of } f \text{ if } f(c) = 0.$$

A linear function $f(x) = mx + b$, with $m \neq 0$, has exactly one zero.

Find the zero of the linear function

$$f(x) = \frac{5}{8}x - 40.$$

We find the value of x for which $f(x) = 0$:

$$\frac{5}{8}x - 40 = 0$$

Setting $f(x) = 0$

$$\frac{5}{8}x = 40$$

Adding 40 on both sides

$$\frac{8}{5} \cdot \frac{5}{8}x = \frac{8}{5} \cdot 40$$

Multiplying by $\frac{8}{5}$ on both sides

$$x = 64.$$

We can check by substituting 64 for x :

$$f(64) = \frac{5}{8} \cdot 64 - 40 = 40 - 40 = 0.$$

The zero of $f(x) = \frac{5}{8}x - 40$ is 64.

SECTION 1.6: SOLVING LINEAR INEQUALITIES

Principles for Solving Linear Inequalities

Addition Principle:

If $a < b$ is true, then $a + c < b + c$ is true.

Multiplication Principle:

If $a < b$ and $c > 0$ are true, then $ac < bc$ is true.

If $a < b$ and $c < 0$ are true, then $ac > bc$ is true.

Similar statements hold for $a \leq b$.

Solve $3x - 2 \leq 22 - 5x$ and graph the solution set.

$$3x - 2 \leq 22 - 5x$$

$$3x - 2 + 5x \leq 22 - 5x + 5x \quad \text{Adding } 5x \text{ on both sides}$$

$$8x - 2 \leq 22$$

$$8x - 2 + 2 \leq 22 + 2 \quad \text{Adding } 2 \text{ on both sides}$$

$$8x \leq 24$$

$$\frac{8x}{8} \leq \frac{24}{8}$$

Dividing by 8 on both sides

$$x \leq 3$$

The solution set is

$$\{x \mid x \leq 3\}, \text{ or } (-\infty, 3].$$

The graph of the solution set is as follows.

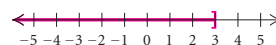

Compound Inequalities

When two inequalities are joined by the word *and* or the word *or*, a compound inequality is formed.

A *Conjunction*:

$$1 < 3x - 20 \text{ and } 3x - 20 \leq 40, \quad \text{or} \\ 1 < 3x - 20 \leq 40$$

A *Disjunction*:

$$8x - 1 \leq -17 \text{ or } 8x - 1 > 7$$

Solve: $1 < 3x - 20 \leq 40$.

$$1 < 3x - 20 \leq 40$$

$$21 < 3x \leq 60 \quad \text{Adding 20}$$

$$7 < x \leq 20 \quad \text{Dividing by 3}$$

The solution set is

$$\{x \mid 7 < x \leq 20\}, \quad \text{or} \quad (7, 20].$$

Solve: $8x - 1 \leq -17$ or $8x - 1 > 7$.

$$8x - 1 \leq -17 \quad \text{or} \quad 8x - 1 > 7$$

$$8x \leq -16 \quad \text{or} \quad 8x > 8 \quad \text{Adding 1}$$

$$x \leq -2 \quad \text{or} \quad x > 1 \quad \text{Dividing by 8}$$

The solution set is

$$\{x \mid x \leq -2 \text{ or } x > 1\}, \quad \text{or} \quad (-\infty, -2] \cup (1, \infty).$$

REVIEW EXERCISES

Answers to all of the review exercises appear in the answer section at the back of the book. If you get an incorrect answer, restudy the objective indicated in red next to the exercise or the direction line that precedes it.

Determine whether the statement is true or false.

- If the line $ax + y = c$ is perpendicular to the line $x - by = d$, then $\frac{a}{b} = 1$. [1.4]
- The intersection of the lines $y = \frac{1}{2}$ and $x = -5$ is $(-5, \frac{1}{2})$. [1.3]
- The domain of the function $f(x) = \frac{\sqrt{3-x}}{x}$ does not contain -3 and 0 . [1.2]
- The line parallel to the x -axis that passes through $(-\frac{1}{4}, 7)$ is $x = -\frac{1}{4}$. [1.3]
- The zero of a linear function f is the first coordinate of the x -intercept of the graph of $y = f(x)$. [1.5]
- If $a < b$ is true and $c \neq 0$, then $ac < bc$ is true. [1.6]

Use substitution to determine whether the given ordered pairs are solutions of the given equation. [1.1]

- $(3, \frac{24}{9})$, $(0, -9)$; $2x - 9y = -18$
- $(0, 7)$, $(7, 1)$; $y = 7$

Find the intercepts and then graph the line. [1.1]

$$9. \quad 2x - 3y = 6$$

$$10. \quad 10 - 5x = 2y$$

Graph the equation. [1.1]

$$11. \quad y = -\frac{2}{3}x + 1$$

$$12. \quad 2x - 4y = 8$$

$$13. \quad y = 2 - x^2$$

14. Find the distance between $(3, 7)$ and $(-2, 4)$. [1.1]

15. Find the midpoint of the segment with endpoints $(3, 7)$ and $(-2, 4)$. [1.1]

16. Find the center and the radius of the circle with equation $(x + 1)^2 + (y - 3)^2 = 9$. Then graph the circle. [1.1]

Find an equation for a circle satisfying the given conditions. [1.1]

17. Center: $(0, -4)$, radius of length $\frac{3}{2}$

18. Center: $(-2, 6)$, radius of length $\sqrt{13}$

19. Diameter with endpoints $(-3, 5)$ and $(7, 3)$

Determine whether the correspondence is a function. [1.2]

$$20. \quad -6 \longrightarrow 1$$

$$21. \quad h \longrightarrow r$$

$$-1 \longrightarrow 3$$

$$i \longrightarrow s$$

$$2 \longrightarrow 10$$

$$j \longrightarrow t$$

$$7 \longrightarrow 12$$

$$k \longrightarrow t$$

Determine whether the relation is a function. Identify the domain and the range. [1.2]

22. $\{(3, 1), (5, 3), (7, 7), (3, 5)\}$
23. $\{(2, 7), (-2, -7), (7, -2), (0, 2), (1, -4)\}$
24. Given that $f(x) = x^2 - x - 3$, find each of the following. [1.2]
- a) $f(0)$ b) $f(-3)$
 c) $f(a - 1)$ d) $f(-x)$
25. Given that $f(x) = \frac{x - 7}{x + 5}$, find each of the following. [1.2]
- a) $f(7)$ b) $f(x + 1)$
 c) $f(-5)$ d) $f(-\frac{1}{2})$
26. A graph of a function is shown. Find $f(2)$, $f(-4)$, and $f(0)$. [1.2]

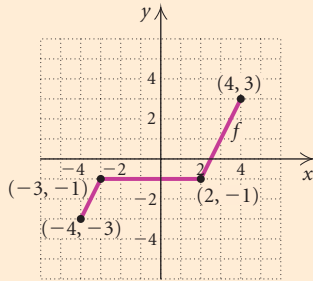

Determine whether the graph is that of a function. [1.2]

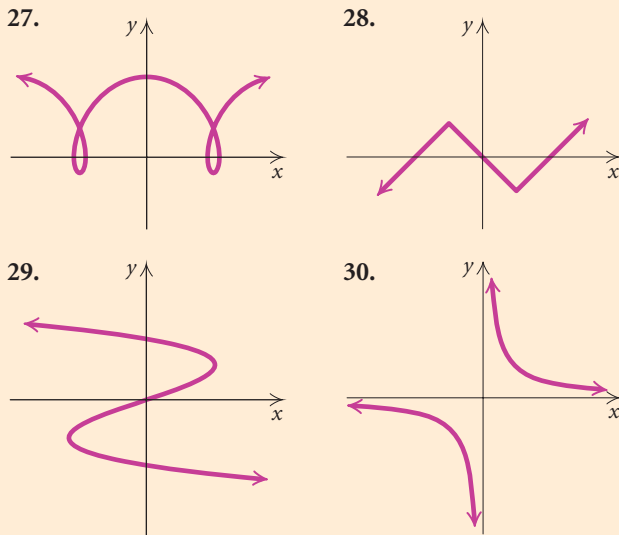

Find the domain of the function. [1.2]

31. $f(x) = 4 - 5x + x^2$
32. $f(x) = \frac{3}{x} + 2$

33. $f(x) = \frac{1}{x^2 - 6x + 5}$

34. $f(x) = \frac{-5x}{|16 - x^2|}$

Graph the function. Then visually estimate the domain and the range. [1.2]

35. $f(x) = \sqrt{16 - x^2}$

36. $g(x) = |x - 5|$

37. $f(x) = x^3 - 7$

38. $h(x) = x^4 + x^2$

In Exercises 39 and 40, the table of data contains input–output values for a function. Answer the following questions. [1.3]

- a) Is the change in the inputs, x , the same?
 b) Is the change in the outputs, y , the same?
 c) Is the function linear?

39.

x	y
-3	8
-2	11
-1	14
0	17
1	20
2	22
3	26

40.

x	y
20	11.8
30	24.2
40	36.6
50	49.0
60	61.4
70	73.8
80	86.2

Find the slope of the line containing the given points. [1.3]

41. $(2, -11), (5, -6)$
42. $(5, 4), (-3, 4)$
43. $(\frac{1}{2}, 3), (\frac{1}{2}, 0)$
44. **Minimum Wage.** The minimum wage was \$5.15 in 1990 and \$7.25 in 2009 (Source: U.S. Department of Labor). Find the average rate of change in the minimum wage from 1990 to 2009. [1.3]

Find the slope and the y -intercept of the line with the given equation. [1.3]

45. $y = -\frac{7}{11}x - 6$
46. $-2x - y = 7$
47. Graph $y = -\frac{1}{4}x + 3$ using the slope and the y -intercept. [1.3]

48. **Total Cost.** Clear County Cable Television charges a \$60 installation fee and \$44 per month for basic service. Write an equation that can be used to determine the total cost $C(t)$ of t months of basic cable television service. Find the total cost of 1 year of service. [1.3]
49. **Temperature and Depth of the Earth.** The function T given by $T(d) = 10d + 20$ can be used to determine the temperature T , in degrees Celsius, at a depth d , in kilometers, inside the earth.
- Find $T(5)$, $T(20)$, and $T(1000)$. [1.3]
 - The radius of the earth is about 5600 km. Use this fact to determine the domain of the function. [1.3]

Write a slope–intercept equation for a line with the following characteristics. [1.4]

- $m = -\frac{2}{3}$, y -intercept $(0, -4)$
- $m = 3$, passes through $(-2, -1)$
- Passes through $(4, 1)$ and $(-2, -1)$
- Write equations of the horizontal line and the vertical line that pass through $(-4, \frac{2}{5})$. [1.4]
- Find a linear function h given $h(-2) = -9$ and $h(4) = 3$. Then find $h(0)$. [1.4]

Determine whether the lines are parallel, perpendicular, or neither. [1.4]

- $3x - 2y = 8$,
 $6x - 4y = 2$
- $y - 2x = 4$,
 $2y - 3x = -7$
- $y = \frac{3}{2}x + 7$,
 $y = -\frac{2}{3}x - 4$

Given the point $(1, -1)$ and the line $2x + 3y = 4$:

- Find an equation of the line containing the given point and parallel to the given line. [1.4]
- Find an equation of the line containing the given point and perpendicular to the given line. [1.4]
- Height of an Indian Elephant.** Sample data in the following table show the height at the shoulders H , in centimeters, of an adult Indian elephant (*Elephas maximus indicus*) that corresponds to the right forefoot circumference c , in centimeters.

Right Forefoot Circumference, c (in centimeters)	Height at the Shoulders, H (in centimeters)
92.3	182.1
98.7	194.8
105.0	207.4
114.2	225.7
120.7	238.6
125.0	247.2

Source: Forest Department of the Government of Kerala (India); Sreekumar, K. P. and G. Nirmalan, *Veterinary Research Communications*: Springer Netherlands, Volume 13, Number 1, January 1989.



Model the data with a linear function where the height, H , is a function of the circumference, c , of the right forefoot. Then using this function, estimate the height at the shoulders of an Indian elephant with a right forefoot circumference of 118 cm. Round the answer to the nearest hundredth. Answers may vary depending on the data points used.

Solve. [1.5]

- $4y - 5 = 1$
- $3x - 4 = 5x + 8$
- $5(3x + 1) = 2(x - 4)$
- $2(n - 3) = 3(n + 5)$
- $\frac{3}{5}y - 2 = \frac{3}{8}$
- $5 - 2x = -2x + 3$
- $x - 13 = -13 + x$

68. **Salt Consumption.** Americans' salt consumption is increasing. The recommended daily intake of salt is 2300 milligrams per person. In 2006, American men consumed an average of 4300 milligrams of salt daily. This was a 54.7% increase over the average daily salt intake in 1974. (Source: National Health and Nutrition Examination Survey) What was the average daily salt intake for men in 1974? Round your answer to the nearest 10 milligrams. [1.5]



69. **Amount of Investment.** Kaleb makes an investment at 5.2% simple interest. At the end of 1 year, the total value of the investment is \$2419.60. How much was originally invested? [1.5]
70. **Flying into a Headwind.** An airplane that can travel 550 mph in still air encounters a 20-mph headwind. How long will it take the plane to travel 1802 mi? [1.5]

In Exercises 71–74, find the zero of the function. [1.5]

71. $f(x) = 6x - 18$
 72. $f(x) = x - 4$
 73. $f(x) = 2 - 10x$
 74. $f(x) = 8 - 2x$

Solve and write interval notation for the solution set. Then graph the solution set. [1.6]

75. $2x - 5 < x + 7$
 76. $3x + 1 \geq 5x + 9$
 77. $-3 \leq 3x + 1 \leq 5$
 78. $-2 < 5x - 4 \leq 6$
 79. $2x < -1$ or $x - 3 > 0$
 80. $3x + 7 \leq 2$ or $2x + 3 \geq 5$

81. **Homeschooled Children in the U.S.** The equation $y = 0.08x + 0.83$ estimates the number of homeschooled children in the U.S., in millions, where x is the number of years after 1999 (Source: Department of Education's National Center for Education Statistics). For what years will the number of homeschooled children exceed 2.0 million? [1.6]
82. **Temperature Conversion.** The formula $C = \frac{5}{9}(F - 32)$ can be used to convert Fahrenheit temperatures F to Celsius temperatures C . For what Fahrenheit temperatures is the Celsius temperature lower than 45°C ? [1.6]
83. The domain of the function

$$f(x) = \frac{x + 3}{8 - 4x}$$

is which of the following? [1.2]

- A. $(-3, 2)$
 B. $(-\infty, 2) \cup (2, \infty)$
 C. $(-\infty, -3) \cup (-3, 2) \cup (2, \infty)$
 D. $(-\infty, -3) \cup (-3, \infty)$
84. The center of the circle described by the equation $(x - 1)^2 + y^2 = 9$ is which of the following? [1.1]
- A. $(-1, 0)$ B. $(1, 0)$
 C. $(0, -3)$ D. $(-1, 3)$
85. The graph of $f(x) = -\frac{1}{2}x - 2$ is which of the following? [1.3]

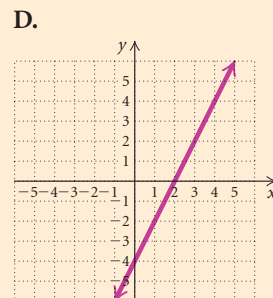
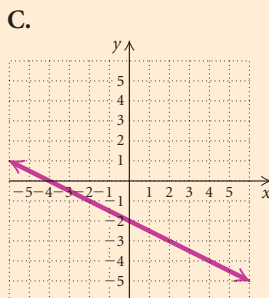
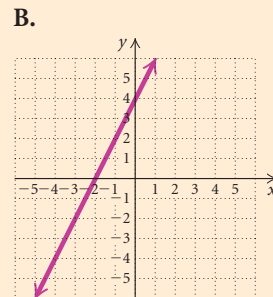
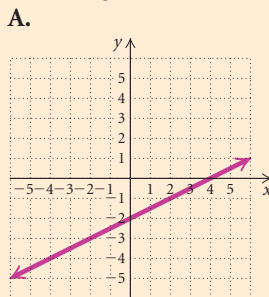

Find the domain of the function.

12. $f(x) = \frac{1}{x - 4}$

13. $g(x) = x^3 + 2$

14. $h(x) = \sqrt{25 - x^2}$

15. a) Graph: $f(x) = |x - 2| + 3$.

b) Visually estimate the domain of $f(x)$.

c) Visually estimate the range of $f(x)$.

Find the slope of the line containing the given points.

16. $(-2, \frac{2}{3}), (-2, 5)$

17. $(4, -10), (-8, 12)$

18. $(-5, 6), (\frac{3}{4}, 6)$

19. **Declining Number Who Smoke.** Daily use of cigarettes by U.S. 12th graders is declining. In 1995, 21.7% of 12th graders smoked daily. This number decreased to 5.9% in 2008 (Source: *Monitoring the Future*, University of Michigan Institute for Social Research and National Institute on Drug Abuse). Find the average rate of change in the percent of 12th graders who smoke from 1995 to 2008.

20. Find the slope and the y -intercept of the line with equation $-3x + 2y = 5$.

21. **Total Cost.** Clear Signal charges \$80 for a cell phone and \$39.95 per month under its standard plan. Write an equation that can be used to determine the total cost, $C(t)$, of operating a Clear Signal cell phone for t months. Then find the total cost for 2 years.

22. Write an equation for the line with $m = -\frac{5}{8}$ and y -intercept $(0, -5)$.

23. Write an equation for the line that passes through $(-5, 4)$ and $(3, -2)$.

24. Write the equation of the vertical line that passes through $(-\frac{3}{8}, 11)$.

25. Determine whether the lines are parallel, perpendicular, or neither.

$$2x + 3y = -12,$$

$$2y - 3x = 8$$

26. Find an equation of the line containing the point $(-1, 3)$ and parallel to the line $x + 2y = -6$.

27. Find an equation of the line containing the point $(-1, 3)$ and perpendicular to the line $x + 2y = -6$.

28. **Miles per Car.** The data in the following table show a decrease in the average miles per passenger car from 2005 to 2008.

Year, x	Average Miles per Passenger Car
2005, 0	12,510
2006, 1	12,485
2007, 2	12,304
2008, 3	11,788

Source: Energy Information Administration Monthly Energy Review, March 2010

Model the data with a linear function and using this function, predict the average number of miles per passenger car in 2010 and in 2013. Answers may vary depending on the data points used.

Solve.

29. $6x + 7 = 1$

30. $2.5 - x = -x + 2.5$

31. $\frac{3}{2}y - 4 = \frac{5}{3}y + 6$

32. $2(4x + 1) = 8 - 3(x - 5)$

33. **Parking-Lot Dimensions.** The parking lot behind Kai's Kafé has a perimeter of 210 m. The width is three-fourths of the length. What are the dimensions of the parking lot?

34. **Pricing.** Jessie's Juice Bar prices its bottled juices by raising the wholesale price 50% and then adding 25¢. What is the wholesale price of a bottle of juice that sells for \$2.95?

35. Find the zero of the function $f(x) = 3x + 9$.

Solve and write interval notation for the solution set. Then graph the solution set.

36. $5 - x \geq 4x + 20$

37. $-7 < 2x + 3 < 9$

38. $2x - 1 \leq 3$ or $5x + 6 \geq 26$

39. **Moving Costs.** Morgan Movers charges \$90 plus \$25 per hour to move households across town. McKinley Movers charges \$40 per hour for crosstown moves. For what lengths of time does it cost less to hire Morgan Movers?

40. The graph of $g(x) = 1 - \frac{1}{2}x$ is which of the following?

A.

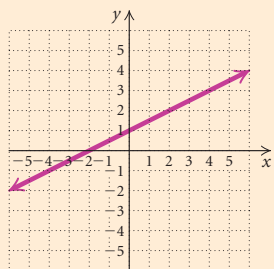

B.

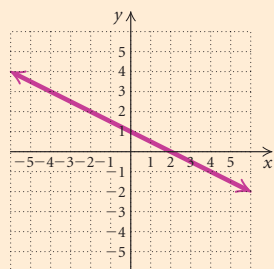

C.

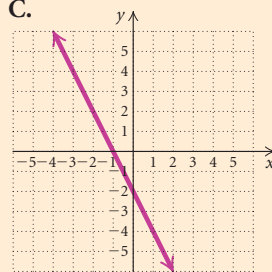

D.

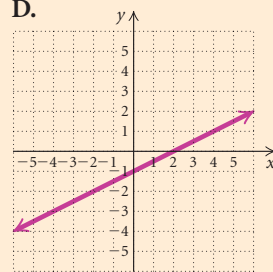

Synthesis

41. Suppose that for some function h , $h(x + 2) = \frac{1}{2}x$. Find $h(-2)$.

More on Functions

CHAPTER

2

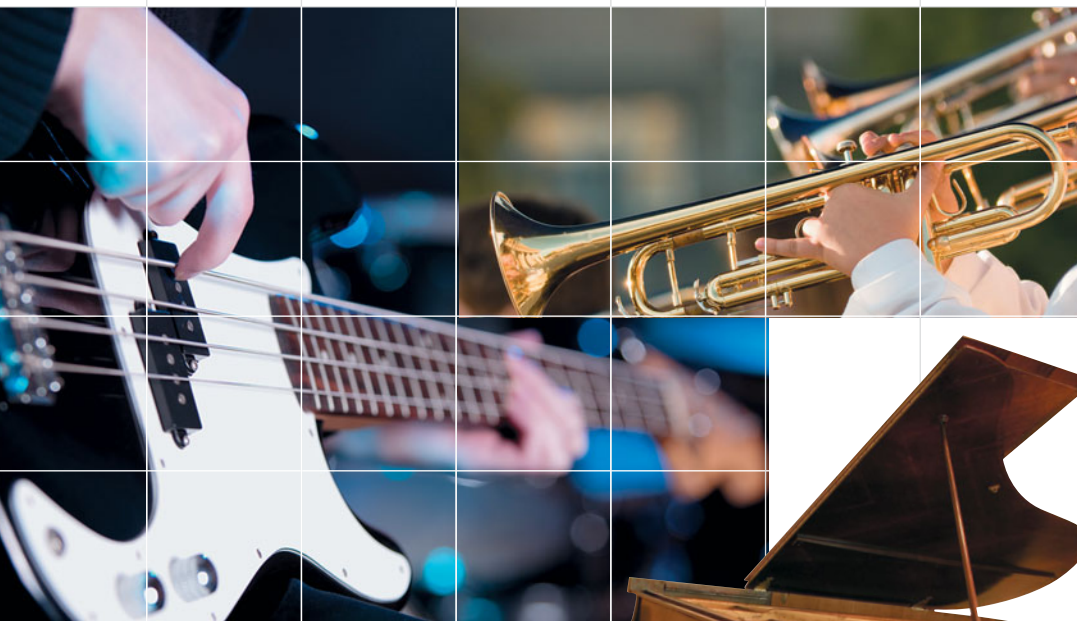

Application

The pitch P of a musical tone varies inversely as its wavelength W . One tone has a pitch of 330 vibrations per second and a wavelength of 3.2 ft. Find the wavelength of another tone that has a pitch of 550 vibrations per second.

This problem appears as Exercise 23 in Section 2.5.

2.1 Increasing, Decreasing, and Piecewise Functions; Applications

2.2 The Algebra of Functions

2.3 The Composition of Functions

Mid-Chapter Mixed Review

2.4 Symmetry and Transformations

Visualizing the Graph

2.5 Variation and Applications

Study Guide

Review Exercises

Chapter Test

Increasing, Decreasing, and Piecewise Functions; Applications

2.1

- ▶ Graph functions, looking for intervals on which the function is increasing, decreasing, or constant, and estimate relative maxima and minima.
- ▶ Given an application, find a function that models the application. Find the domain of the function and function values.
- ▶ Graph functions defined piecewise.

Because functions occur in so many real-world situations, it is important to be able to analyze them carefully.

▶ Increasing, Decreasing, and Constant Functions

On a given interval, if the graph of a function rises from left to right, it is said to be **increasing** on that interval. If the graph drops from left to right, it is said to be **decreasing**. If the function values stay the same from left to right, the function is said to be **constant**.

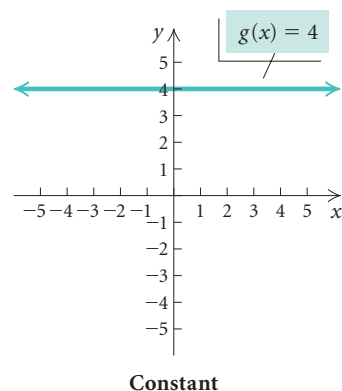
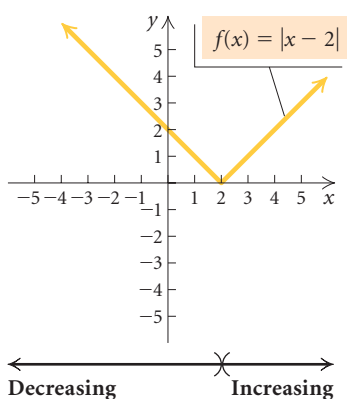
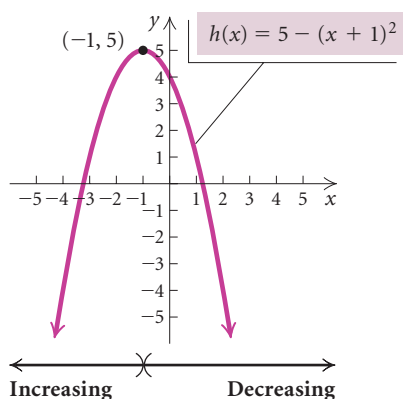

We are led to the following definitions.

Increasing, Decreasing, and Constant Functions

A function f is said to be **increasing** on an *open interval* I , if for all a and b in that interval, $a < b$ implies $f(a) < f(b)$. (See Fig. 1 on the following page.)

A function f is said to be **decreasing** on an *open interval* I , if for all a and b in that interval, $a < b$ implies $f(a) > f(b)$. (See Fig. 2.)

A function f is said to be **constant** on an *open interval* I , if for all a and b in that interval, $f(a) = f(b)$. (See Fig. 3.)

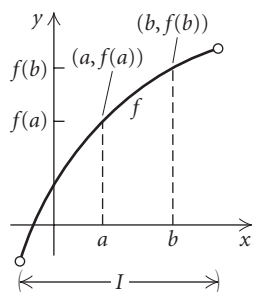

For $a < b$ in I , $f(a) < f(b)$;
 f is **increasing** on I .

Figure 1

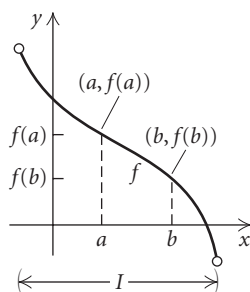

For $a < b$ in I , $f(a) > f(b)$;
 f is **decreasing** on I .

Figure 2

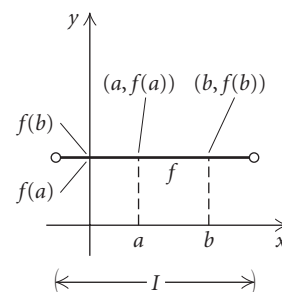

For all a and b in I , $f(a) = f(b)$;
 f is **constant** on I .

Figure 3

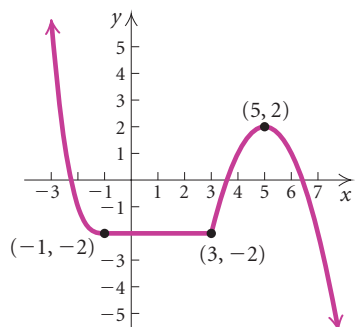

EXAMPLE 1 Determine the intervals on which the function in the figure at left is (a) increasing; (b) decreasing; (c) constant.

Solution When expressing interval(s) on which a function is increasing, decreasing, or constant, we consider only values in the *domain* of the function. Since the domain of this function is $(-\infty, \infty)$, we consider all real values of x .

- As x -values (that is, values in the domain) increase from $x = 3$ to $x = 5$, the y -values (that is, values in the range) increase from -2 to 2 . Thus the function is increasing on the interval $(3, 5)$.
- As x -values increase from **negative infinity** to -1 , y -values decrease; y -values also decrease as x -values increase from 5 to **positive infinity**. Thus the function is decreasing on the intervals $(-\infty, -1)$ and $(5, \infty)$.
- As x -values increase from -1 to 3 , y remains -2 . The function is constant on the interval $(-1, 3)$.

Now Try Exercise 5.

In calculus, the slope of a line tangent to the graph of a function at a particular point is used to determine whether the function is increasing, decreasing, or constant at that point. If the slope is positive, the function is increasing; if the slope is negative, the function is decreasing; if the slope is 0 , the function is constant. Since slope cannot be both positive and negative at the same point, a function cannot be both increasing and decreasing at a specific point. For this reason, increasing, decreasing, and constant intervals are expressed in *open interval* notation. In Example 1, if $[3, 5]$ had been used for the increasing interval and $[5, \infty)$ for a decreasing interval, the function would be both increasing and decreasing at $x = 5$. This is not possible.

► Relative Maximum and Minimum Values

Consider the graph shown at the top of the next page. Note the “peaks” and “valleys” at the x -values c_1 , c_2 , and c_3 . The function value $f(c_2)$ is called a **relative maximum** (plural, **maxima**). Each of the function values $f(c_1)$ and $f(c_3)$ is called a **relative minimum** (plural, **minima**).

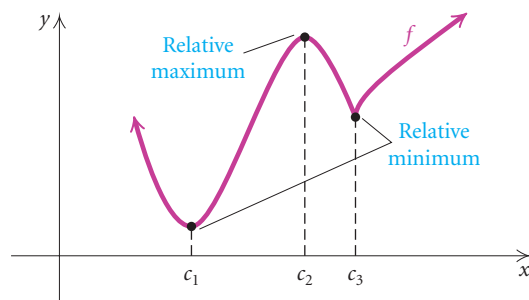

STUDY TIP

Have reasonable expectations about the time you need to study for this course. Make an hour-by-hour schedule of your typical week. Include work, school, home, sleep, study, and leisure times. Try to schedule time for study when you are most alert. Choose a setting that will enable you to focus and concentrate. Plan for success, and it will happen.

TECHNOLOGY CONNECTION

We can approximate relative maximum and minimum values with the MAXIMUM and MINIMUM features from the CALC menu on a graphing calculator. See the online *Graphing Calculator Manual* for more information on this procedure.

$$y = 0.1x^3 - 0.6x^2 - 0.1x + 2$$

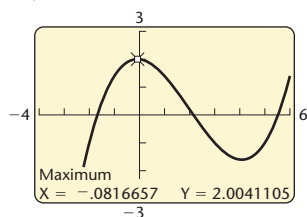

$$y = 0.1x^3 - 0.6x^2 - 0.1x + 2$$

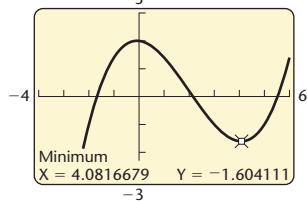

Relative Maxima and Minima

Suppose that f is a function for which $f(c)$ exists for some c in the domain of f . Then:

$f(c)$ is a **relative maximum** if there exists an *open* interval I containing c such that $f(c) > f(x)$, for all x in I where $x \neq c$; and

$f(c)$ is a **relative minimum** if there exists an *open* interval I containing c such that $f(c) < f(x)$, for all x in I where $x \neq c$.

Simply stated, $f(c)$ is a *relative maximum* if $(c, f(c))$ is the highest point in some *open* interval, and $f(c)$ is a *relative minimum* if $(c, f(c))$ is the lowest point in some *open* interval.

If you take a calculus course, you will learn a method for determining exact values of relative maxima and minima. In Section 3.3, we will find exact maximum and minimum values of quadratic functions algebraically.

EXAMPLE 2 Using the graph shown below, determine any relative maxima or minima of the function $f(x) = 0.1x^3 - 0.6x^2 - 0.1x + 2$ and the intervals on which the function is increasing or decreasing.

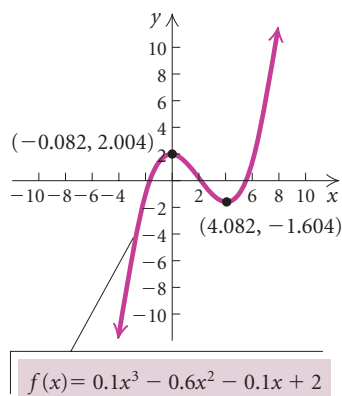

Solution We see that the *relative maximum* value of the function is 2.004. It occurs when $x = -0.082$. We also see the *relative minimum*: -1.604 at $x = 4.082$.

We note that the graph starts rising, or increasing, from the left and stops increasing at the relative maximum. From this point, the graph decreases to the relative minimum and then begins to rise again. The function is *increasing* on the intervals

$$(-\infty, -0.082) \quad \text{and} \quad (4.082, \infty)$$

and *decreasing* on the interval

$$(-0.082, 4.082).$$

Let's summarize our results.

Relative maximum	2.004 at $x = -0.082$
Relative minimum	-1.604 at $x = 4.082$
Increasing	$(-\infty, -0.082), (4.082, \infty)$
Decreasing	$(-0.082, 4.082)$

 Now Try Exercise 15.

► Applications of Functions

Many real-world situations can be modeled by functions.

EXAMPLE 3 Car Distance. Elena and Thomas drive away from a restaurant at right angles to each other. Elena's speed is 35 mph and Thomas' is 40 mph.

- Express the distance between the cars as a function of time, $d(t)$.
- Find the domain of the function.

Solution

- Suppose 1 hr goes by. At that time, Elena has traveled 35 mi and Thomas has traveled 40 mi. We can use the Pythagorean theorem to find the distance between them. This distance would be the length of the hypotenuse of a triangle with legs measuring 35 mi and 40 mi. After 2 hr, the triangle's legs would measure $2 \cdot 35$, or 70 mi, and $2 \cdot 40$, or 80 mi. Noting that the distances will always be changing, we make a drawing and let $t =$ the time, in hours, that Elena and Thomas have been driving since leaving the restaurant.

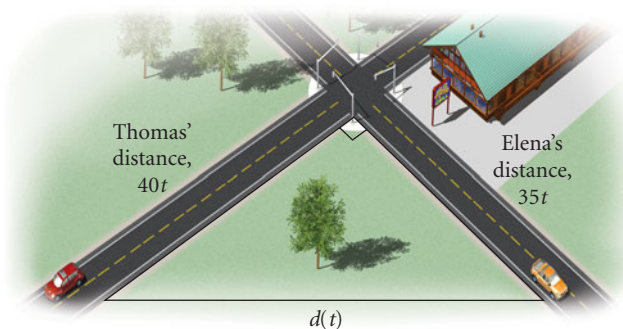

After t hours, Elena has traveled $35t$ miles and Thomas $40t$ miles. We now use the Pythagorean theorem:

$$[d(t)]^2 = (35t)^2 + (40t)^2.$$

Because distance must be nonnegative, we need consider only the positive square root when solving for $d(t)$:

$$\begin{aligned} d(t) &= \sqrt{(35t)^2 + (40t)^2} \\ &= \sqrt{1225t^2 + 1600t^2} \\ &= \sqrt{2825t^2} \\ &\approx 53.15|t| && \text{Approximating the root to two decimal places} \\ &\approx 53.15t. && \text{Since } t \geq 0, |t| = t. \end{aligned}$$

Thus, $d(t) = 53.15t$, $t \geq 0$.

- b) Since the time traveled, t , must be nonnegative, the domain is the set of nonnegative real numbers $[0, \infty)$.

 **Now Try Exercise 25.**

EXAMPLE 4 Storage Area. Jenna's restaurant supply store has 20 ft of dividers with which to set off a rectangular area for the storage of overstock. If a corner of the store is used for the storage area, the partition need only form two sides of a rectangle.

- Express the floor area of the storage space as a function of the length of the partition.
- Find the domain of the function.
- Using the graph shown below, determine the dimensions that maximize the area of the floor.

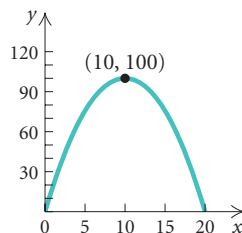

Solution

- a) Note that the dividers will form two sides of a rectangle. If, for example, 14 ft of dividers are used for the length of the rectangle, that would leave $20 - 14$, or 6 ft of dividers for the width. Thus if x = the length, in feet, of the rectangle, then $20 - x$ = the width. We represent this information in a sketch, as shown below.

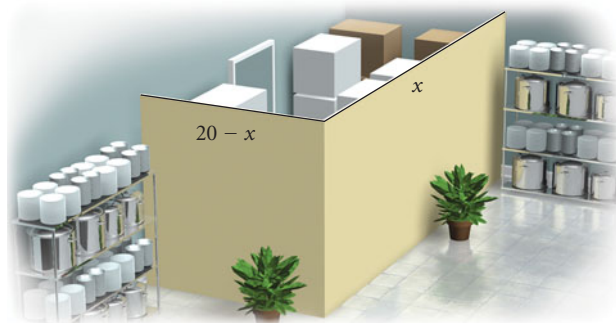

The area, $A(x)$, is given by

$$\begin{aligned} A(x) &= x(20 - x) && \text{Area} = \text{length} \cdot \text{width.} \\ &= 20x - x^2. \end{aligned}$$

The function $A(x) = 20x - x^2$ can be used to express the rectangle's area as a function of the length.

- b) Because the rectangle's length and width must be positive and only 20 ft of dividers are available, we restrict the domain of A to $\{x \mid 0 < x < 20\}$, that is, the interval $(0, 20)$.
- c) On the graph of the function on the previous page, the maximum value of the area on the interval $(0, 20)$ appears to be 100 when $x = 10$. Thus the dimensions that maximize the area are

$$\text{Length} = x = 10 \text{ ft} \quad \text{and}$$

$$\text{Width} = 20 - x = 20 - 10 = 10 \text{ ft.}$$

 **Now Try Exercise 31.**

► Functions Defined Piecewise

Sometimes functions are defined **piecewise** using different output formulas for different pieces, or parts, of the domain.

EXAMPLE 5 For the function defined as

$$f(x) = \begin{cases} x + 1, & \text{for } x < -2, \\ 5, & \text{for } -2 \leq x \leq 3, \\ x^2, & \text{for } x > 3, \end{cases}$$

find $f(-5)$, $f(-3)$, $f(0)$, $f(3)$, $f(4)$, and $f(10)$.

Solution First, we determine which part of the domain contains the given input. Then we use the corresponding formula to find the output.

Since $-5 < -2$, we use the formula $f(x) = x + 1$:

$$f(-5) = -5 + 1 = -4.$$

Since $-3 < -2$, we use the formula $f(x) = x + 1$ again:

$$f(-3) = -3 + 1 = -2.$$

Since $-2 \leq 0 \leq 3$, we use the formula $f(x) = 5$:

$$f(0) = 5.$$

Since $-2 \leq 3 \leq 3$, we use the formula $f(x) = 5$ a second time:

$$f(3) = 5.$$

Since $4 > 3$, we use the formula $f(x) = x^2$:

$$f(4) = 4^2 = 16.$$

Since $10 > 3$, we once again use the formula $f(x) = x^2$:

$$f(10) = 10^2 = 100.$$

 **Now Try Exercise 35.**

Table 1

x ($x < 3$)	$g(x) = \frac{1}{3}x + 3$
-3	2
0	3
2	$3\frac{2}{3}$

Table 2

x ($x \geq 3$)	$g(x) = -x$
3	-3
4	-4
6	-6

Table 3

x ($x \leq 0$)	$f(x) = 4$
-5	4
-2	4
0	4

Table 4

x ($0 < x \leq 2$)	$f(x) = 4 - x^2$
$\frac{1}{2}$	$3\frac{3}{4}$
1	3
2	0

EXAMPLE 6 Graph the function defined as

$$g(x) = \begin{cases} \frac{1}{3}x + 3, & \text{for } x < 3, \\ -x, & \text{for } x \geq 3. \end{cases}$$

Solution Since the function is defined in two pieces, or parts, we create the graph in two parts.

a) We graph $g(x) = \frac{1}{3}x + 3$ *only* for inputs x less than 3. That is, we use $g(x) = \frac{1}{3}x + 3$ *only* for x -values in the interval $(-\infty, 3)$. Some ordered pairs that are solutions of this piece of the function are shown in Table 1.

b) We graph $g(x) = -x$ *only* for inputs x greater than or equal to 3. That is, we use $g(x) = -x$ *only* for x -values in the interval $[3, \infty)$. Some ordered pairs that are solutions of this piece of the function are shown in Table 2.

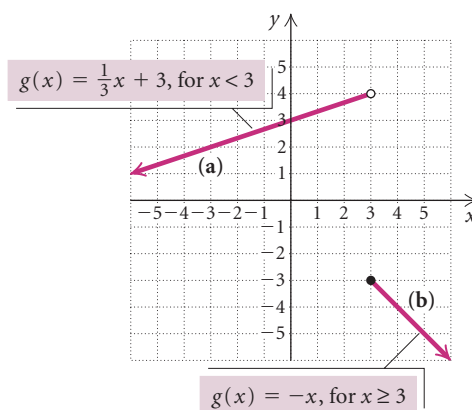

Now Try Exercise 39.

EXAMPLE 7 Graph the function defined as

$$f(x) = \begin{cases} 4, & \text{for } x \leq 0, \\ 4 - x^2, & \text{for } 0 < x \leq 2, \\ 2x - 6, & \text{for } x > 2. \end{cases}$$

Solution We create the graph in three pieces, or parts.

a) We graph $f(x) = 4$ *only* for inputs x less than or equal to 0. That is, we use $f(x) = 4$ *only* for x -values in the interval $(-\infty, 0]$. Some ordered pairs that are solutions of this piece of the function are shown in Table 3.

b) We graph $f(x) = 4 - x^2$ *only* for inputs x greater than 0 and less than or equal to 2. That is, we use $f(x) = 4 - x^2$ *only* for x -values in the interval $(0, 2]$. Some ordered pairs that are solutions of this piece of the function are shown in Table 4.

c) We graph $f(x) = 2x - 6$ *only* for inputs x greater than 2. That is, we use $f(x) = 2x - 6$ *only* for x -values in the interval $(2, \infty)$. Some ordered pairs that are solutions of this piece of the function are shown in Table 5 on the next page.

Table 5

x ($x > 2$)	$f(x) = 2x - 6$
$2\frac{1}{2}$	-1
3	0
5	4

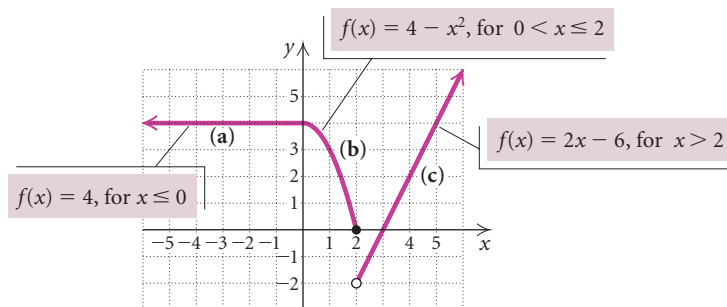

➔ Now Try Exercise 43.

EXAMPLE 8 Graph the function defined as

$$f(x) = \begin{cases} \frac{x^2 - 4}{x + 2}, & \text{for } x \neq -2, \\ 3, & \text{for } x = -2. \end{cases}$$

Solution When $x \neq -2$, the denominator of $(x^2 - 4)/(x + 2)$ is nonzero, so we can simplify:

$$\frac{x^2 - 4}{x + 2} = \frac{(x + 2)(x - 2)}{x + 2} = x - 2.$$

Thus,

$$f(x) = x - 2, \quad \text{for } x \neq -2.$$

The graph of this part of the function consists of a line with a “hole” at the point $(-2, -4)$, indicated by the open circle. The hole occurs because the piece of the function represented by $(x^2 - 4)/(x + 2)$ is not defined for $x = -2$. By the definition of the function, we see that $f(-2) = 3$, so we plot the point $(-2, 3)$ above the open circle.

➔ Now Try Exercise 47.

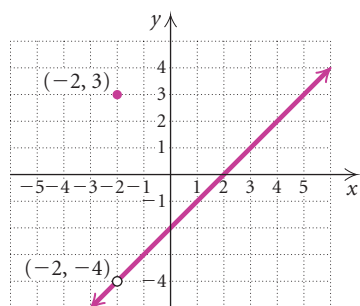

A piecewise function with importance in calculus and computer programming is the **greatest integer function**, f , denoted $f(x) = \llbracket x \rrbracket$, or $\text{int}(x)$.

Greatest Integer Function

$f(x) = \llbracket x \rrbracket =$ the greatest integer less than or equal to x .

The greatest integer function pairs each input with the greatest integer less than or equal to that input. Thus x -values 1 , $1\frac{1}{2}$, and 1.8 are all paired with the y -value 1 . Other pairings are shown below.

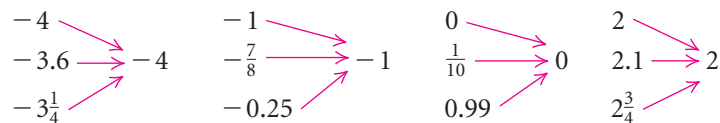

TECHNOLOGY CONNECTION

When we are graphing the greatest integer function

$$f(x) = \llbracket x \rrbracket$$

on a graphing calculator, DOT mode is preferable, although it does not show the open dots at the endpoints of segments.

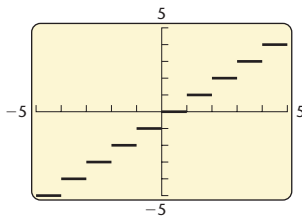

$y = \text{int}(x)$, DOT mode

EXAMPLE 9 Graph $f(x) = \llbracket x \rrbracket$ and determine its domain and range.

Solution The greatest integer function can also be defined as a piecewise function with an infinite number of statements.

$$f(x) = \llbracket x \rrbracket = \begin{cases} \vdots \\ -3, & \text{for } -3 \leq x < -2, \\ -2, & \text{for } -2 \leq x < -1, \\ -1, & \text{for } -1 \leq x < 0, \\ 0, & \text{for } 0 \leq x < 1, \\ 1, & \text{for } 1 \leq x < 2, \\ 2, & \text{for } 2 \leq x < 3, \\ 3, & \text{for } 3 \leq x < 4, \\ \vdots \end{cases}$$

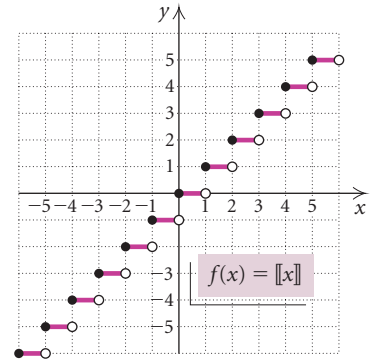

We see that the domain of this function is the set of all real numbers, $(-\infty, \infty)$, and the range is the set of all integers, $\{\dots, -3, -2, -1, 0, 1, 2, 3, \dots\}$.

Now Try Exercise 51.

2.1 Exercise Set

Determine the intervals on which the function is (a) increasing; (b) decreasing; (c) constant.

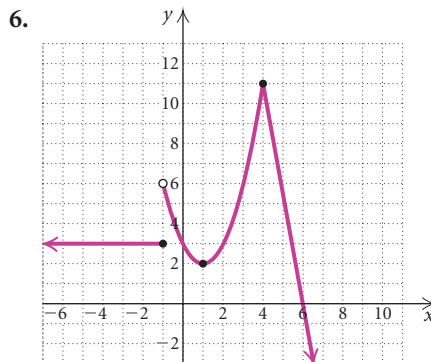
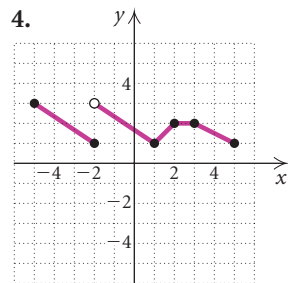
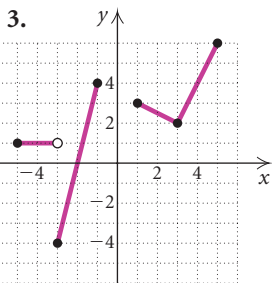
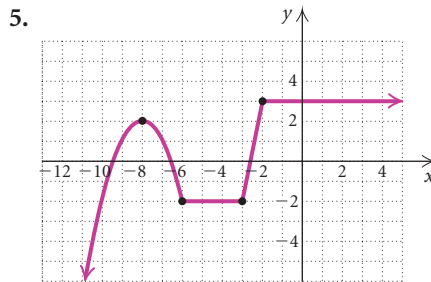
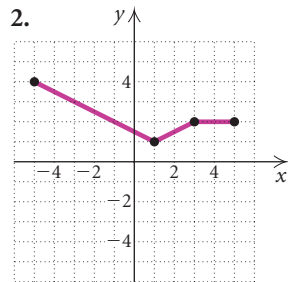
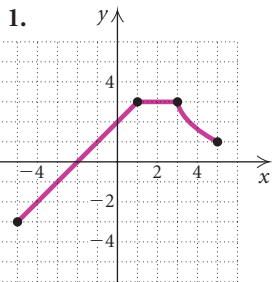

- 7.–12. Determine the domain and the range of each of the functions graphed in Exercises 1–6.

Using the graph, determine any relative maxima or minima of the function and the intervals on which the function is increasing or decreasing.

13. $f(x) = -x^2 + 5x - 3$

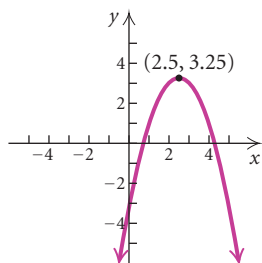

14. $f(x) = x^2 - 2x + 3$

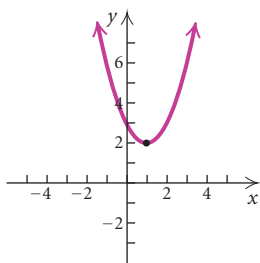

15. $f(x) = \frac{1}{4}x^3 - \frac{1}{2}x^2 - x + 2$

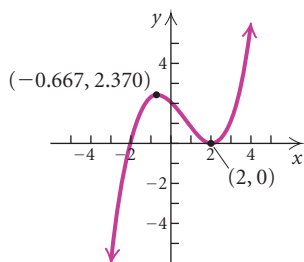

16. $f(x) = -0.09x^3 + 0.5x^2 - 0.1x + 1$

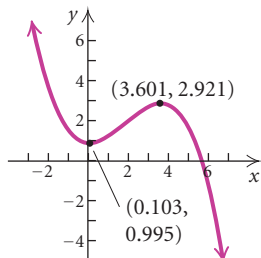

Graph the function. Estimate the intervals on which the function is increasing or decreasing and any relative maxima or minima.

17. $f(x) = x^2$

18. $f(x) = 4 - x^2$

19. $f(x) = 5 - |x|$

20. $f(x) = |x + 3| - 5$

21. $f(x) = x^2 - 6x + 10$

22. $f(x) = -x^2 - 8x - 9$

23. **Garden Area.** Creative Landscaping has 60 yd of fencing with which to enclose a rectangular flower garden. If the garden is x yards long, express the garden's area as a function of the length.

24. **Triangular Scarf.** A seamstress is designing a triangular scarf so that the length of the base of the triangle, in inches, is 7 less than twice the height h . Express the area of the scarf as a function of the height.

25. **Rising Balloon.** A hot-air balloon rises straight up from the ground at a rate of 120 ft/min. The balloon is tracked from a rangefinder on the ground at point P , which is 400 ft from the release point Q of the balloon. Let d = the distance from the balloon to the rangefinder and t = the time, in minutes, since the balloon was released. Express d as a function of t .

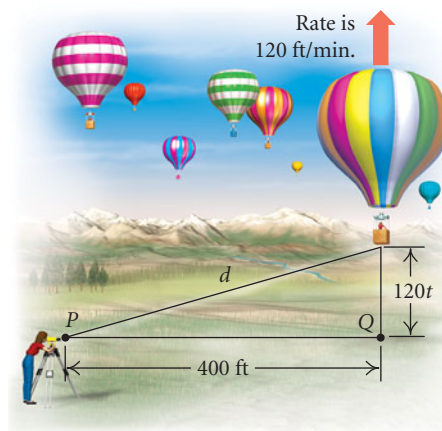

26. **Airplane Distance.** An airplane is flying at an altitude of 3700 ft. The slanted distance directly to the airport is d feet. Express the horizontal distance h as a function of d .

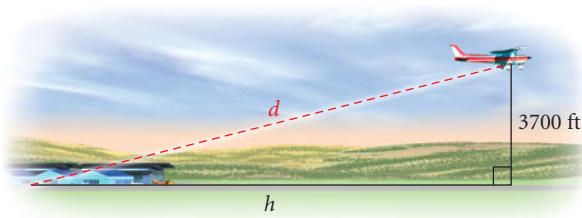

27. **Inscribed Rhombus.** A rhombus is inscribed in a rectangle that is w meters wide with a perimeter of 40 m. Each vertex of the rhombus is a midpoint of a side of the rectangle. Express the area of the rhombus as a function of the rectangle's width.

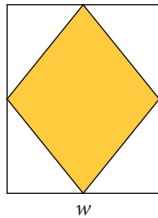

28. **Carpet Area.** A carpet installer uses 46 ft of linen tape to bind the edges of a rectangular hall runner. If the runner is w feet wide, express its area as a function of the width.
29. **Golf Distance Finder.** A device used in golf to estimate the distance d , in yards, to a hole measures the size s , in inches, that the 7-ft pin appears to be in a viewfinder. Express the distance d as a function of s .

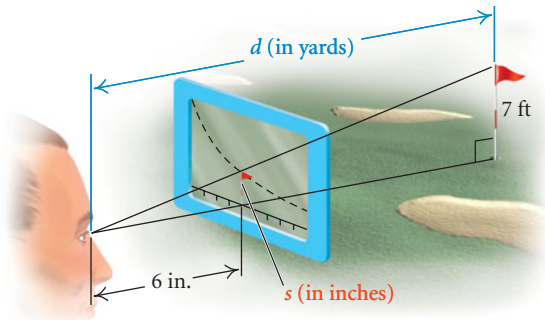

30. **Gas Tank Volume.** A gas tank has ends that are hemispheres of radius r ft. The cylindrical midsection is 6 ft long. Express the volume of the tank as a function of r .

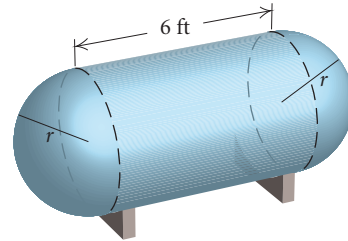

31. **Play Space.** A day-care center has 30 ft of dividers with which to enclose a rectangular play space in a corner of a large room. The sides against the wall require no partition. Suppose the play space is x feet long.



- Express the area of the play space as a function of x .
- Find the domain of the function.
- Using the graph shown below, determine the dimensions that yield the maximum area.

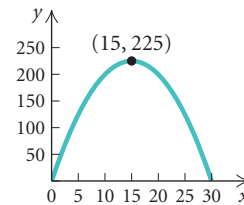

32. **Corral Design.** A rancher has 360 yd of fencing with which to enclose two adjacent rectangular corrals, one for horses and one for cattle. A river forms one side of the corrals. Suppose the width of each corral is x yards.



- Express the total area of the two corrals as a function of x .
- Find the domain of the function.
- Using the graph of the function shown below, determine the dimensions that yield the maximum area.

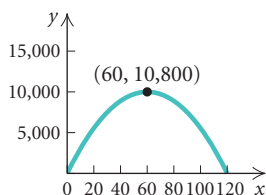

33. **Volume of a Box.** From a 12-cm by 12-cm piece of cardboard, square corners are cut out so that the sides can be folded up to make a box.

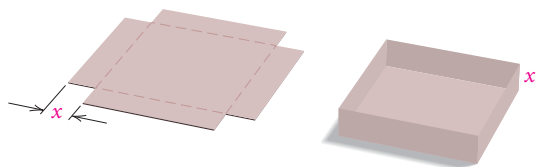

- Express the volume of the box as a function of the side x , in centimeters, of a cut-out square.
- Find the domain of the function.
- Using the graph of the function shown below, determine the dimensions that yield the maximum volume.

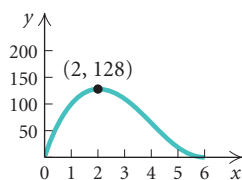

34. **Molding Plastics.** Plastics Unlimited plans to produce a one-component vertical file by bending the long side of an 8-in. by 14-in. sheet of plastic along two lines to form a \sqcup shape.

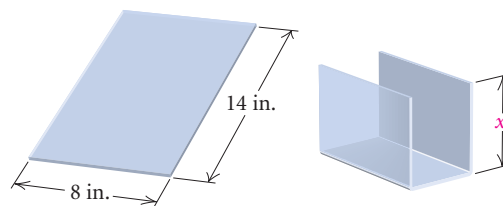

- Express the volume of the file as a function of the height x , in inches, of the file.
- Find the domain of the function.
- Using the graph of the function shown below, determine how tall the file should be in order to maximize the volume the file can hold.

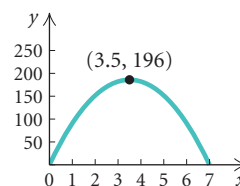

For each piecewise function, find the specified function values.

- $$g(x) = \begin{cases} x + 4, & \text{for } x \leq 1, \\ 8 - x, & \text{for } x > 1 \end{cases}$$

$$g(-4), g(0), g(1), \text{ and } g(3)$$
- $$f(x) = \begin{cases} 3, & \text{for } x \leq -2, \\ \frac{1}{2}x + 6, & \text{for } x > -2 \end{cases}$$

$$f(-5), f(-2), f(0), \text{ and } f(2)$$
- $$h(x) = \begin{cases} -3x - 18, & \text{for } x < -5, \\ 1, & \text{for } -5 \leq x < 1, \\ x + 2, & \text{for } x \geq 1 \end{cases}$$

$$h(-5), h(0), h(1), \text{ and } h(4)$$
- $$f(x) = \begin{cases} -5x - 8, & \text{for } x < -2, \\ \frac{1}{2}x + 5, & \text{for } -2 \leq x \leq 4, \\ 10 - 2x, & \text{for } x > 4 \end{cases}$$

$$f(-4), f(-2), f(4), \text{ and } f(6)$$

Graph each of the following.

- $$f(x) = \begin{cases} \frac{1}{2}x, & \text{for } x < 0, \\ x + 3, & \text{for } x \geq 0 \end{cases}$$
- $$f(x) = \begin{cases} -\frac{1}{3}x + 2, & \text{for } x \leq 0, \\ x - 5, & \text{for } x > 0 \end{cases}$$

41. $f(x) = \begin{cases} -\frac{3}{4}x + 2, & \text{for } x < 4, \\ -1, & \text{for } x \geq 4 \end{cases}$

42. $h(x) = \begin{cases} 2x - 1, & \text{for } x < 2, \\ 2 - x, & \text{for } x \geq 2 \end{cases}$

43. $f(x) = \begin{cases} x + 1, & \text{for } x \leq -3, \\ -1, & \text{for } -3 < x < 4, \\ \frac{1}{2}x, & \text{for } x \geq 4 \end{cases}$

44. $f(x) = \begin{cases} 4, & \text{for } x \leq -2, \\ x + 1, & \text{for } -2 < x < 3, \\ -x, & \text{for } x \geq 3 \end{cases}$

45. $g(x) = \begin{cases} \frac{1}{2}x - 1, & \text{for } x < 0, \\ 3, & \text{for } 0 \leq x \leq 1, \\ -2x, & \text{for } x > 1 \end{cases}$

46. $f(x) = \begin{cases} \frac{x^2 - 9}{x + 3}, & \text{for } x \neq -3, \\ 5, & \text{for } x = -3 \end{cases}$

47. $f(x) = \begin{cases} 2, & \text{for } x = 5, \\ \frac{x^2 - 25}{x - 5}, & \text{for } x \neq 5 \end{cases}$

48. $f(x) = \begin{cases} \frac{x^2 + 3x + 2}{x + 1}, & \text{for } x \neq -1, \\ 7, & \text{for } x = -1 \end{cases}$

49. $f(x) = \llbracket x \rrbracket$ 50. $f(x) = 2\llbracket x \rrbracket$

51. $g(x) = 1 + \llbracket x \rrbracket$ 52. $h(x) = \frac{1}{2}\llbracket x \rrbracket - 2$

53.–58. Find the domain and the range of each of the functions defined in Exercises 39–44.

Determine the domain and the range of the piecewise function. Then write an equation for the function.

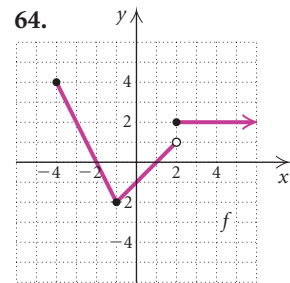
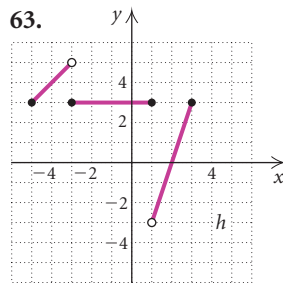
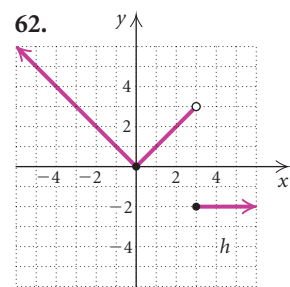
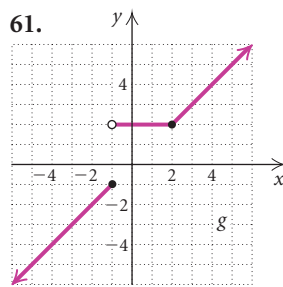
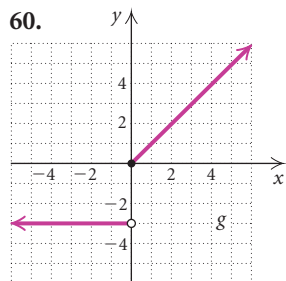
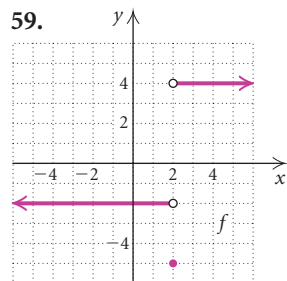

Skill Maintenance

65. Given $f(x) = 5x^2 - 7$, find each of the following.

- a) $f(-3)$
- b) $f(3)$
- c) $f(a)$
- d) $f(-a)$

66. Given $f(x) = 4x^3 - 5x$, find each of the following.

- a) $f(2)$
- b) $f(-2)$
- c) $f(a)$
- d) $f(-a)$

67. Write an equation of the line perpendicular to the graph of the line $8x - y = 10$ and containing the point $(-1, 1)$.

68. Find the slope and the y -intercept of the line with equation $2x - 9y + 1 = 0$.

Synthesis

69. **Parking Costs.** A parking garage charges \$2 for up to (but not including) 1 hr of parking, \$4 for up to 2 hr of parking, \$6 for up to 3 hr of parking, and so on. Let $C(t)$ = the cost of parking for t hours.

- a) Graph the function.
- b) Write an equation for $C(t)$ using the greatest integer notation $\llbracket t \rrbracket$.

70. If $[x + 2] = -3$, what are the possible inputs for x ?
71. If $([x])^2 = 25$, what are the possible inputs for x ?
72. **Minimizing Power Line Costs.** A power line is constructed from a power station at point A to an island at point I, which is 1 mi directly out in the water from a point B on the shore. Point B is 4 mi downshore from the power station at A. It costs \$5000 per mile to lay the power line under water and \$3000 per mile to lay the power line under ground. The line comes to the shore at point S downshore from A. Let $x =$ the distance from B to S.

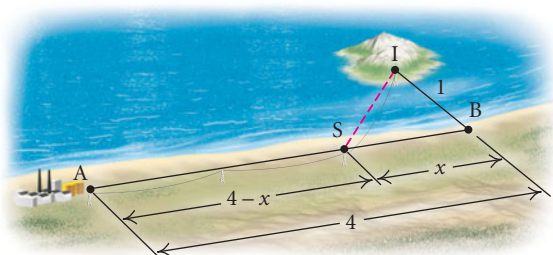

- a) Express the cost C of laying the line as a function of x .
- b) At what distance x from point B should the line come to shore in order to minimize cost?

73. **Volume of an Inscribed Cylinder.** A right circular cylinder of height h and radius r is inscribed in a right circular cone with a height of 10 ft and a base with radius 6 ft.

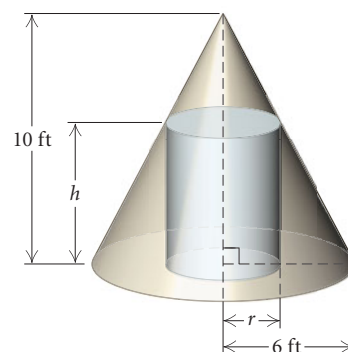

- a) Express the height h of the cylinder as a function of r .
- b) Express the volume V of the cylinder as a function of r .
- c) Express the volume V of the cylinder as a function of h .

The Algebra of Functions

2.2

- ▶ Find the sum, the difference, the product, and the quotient of two functions, and determine the domains of the resulting functions.
- ▶ Find the difference quotient for a function.

▶ The Algebra of Functions: Sums, Differences, Products, and Quotients

We now use addition, subtraction, multiplication, and division to combine functions and obtain new functions.

Consider the following two functions f and g :

$$f(x) = x + 2 \quad \text{and} \quad g(x) = x^2 + 1.$$

Since $f(3) = 3 + 2 = 5$ and $g(3) = 3^2 + 1 = 10$, we have

$$f(3) + g(3) = 5 + 10 = 15,$$

$$f(3) - g(3) = 5 - 10 = -5,$$

$$f(3) \cdot g(3) = 5 \cdot 10 = 50,$$

and

$$\frac{f(3)}{g(3)} = \frac{5}{10} = \frac{1}{2}.$$

In fact, so long as x is in the domain of *both* f and g , we can easily compute $f(x) + g(x)$, $f(x) - g(x)$, $f(x) \cdot g(x)$, and, assuming $g(x) \neq 0$, $f(x)/g(x)$. We use the notation shown below.

Sums, Differences, Products, and Quotients of Functions

If f and g are functions and x is in the domain of each function, then:

$$(f + g)(x) = f(x) + g(x),$$

$$(f - g)(x) = f(x) - g(x),$$

$$(fg)(x) = f(x) \cdot g(x),$$

$$(f/g)(x) = f(x)/g(x), \text{ provided } g(x) \neq 0.$$

EXAMPLE 1 Given that $f(x) = x + 1$ and $g(x) = \sqrt{x + 3}$, find each of the following.

- a) $(f + g)(x)$ b) $(f + g)(6)$ c) $(f + g)(-4)$

Solution

a) $(f + g)(x) = f(x) + g(x)$
 $= x + 1 + \sqrt{x + 3}$ **This cannot be simplified.**

- b) We can find $(f + g)(6)$ provided 6 is in the domain of *each* function. The domain of f is all real numbers. The domain of g is all real numbers x for which $x + 3 \geq 0$, or $x \geq -3$. This is the interval $[-3, \infty)$. We see that 6 is in both domains, so we have

$$f(6) = 6 + 1 = 7, \quad g(6) = \sqrt{6 + 3} = \sqrt{9} = 3, \quad \text{and}$$

$$(f + g)(6) = f(6) + g(6) = 7 + 3 = 10.$$

Another method is to use the formula found in part (a):

$$(f + g)(6) = 6 + 1 + \sqrt{6 + 3} = 7 + \sqrt{9} = 7 + 3 = 10.$$

- c) To find $(f + g)(-4)$, we must first determine whether -4 is in the domain of both functions. We note that -4 is not in the domain of g , $[-3, \infty)$. That is, $\sqrt{-4 + 3}$ is not a real number. Thus, $(f + g)(-4)$ does not exist.

 **Now Try Exercise 15.**

It is useful to view the concept of the sum of two functions graphically. In the graph below, we see the graphs of two functions f and g and their sum, $f + g$. Consider finding $(f + g)(4)$, or $f(4) + g(4)$. We can locate $g(4)$ on the graph of g and measure it. Then we add that length on top of $f(4)$ on the graph of f . The sum gives us $(f + g)(4)$.

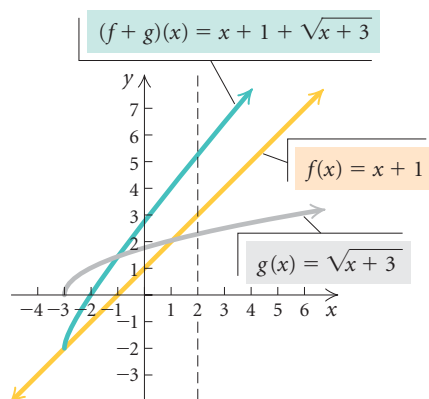
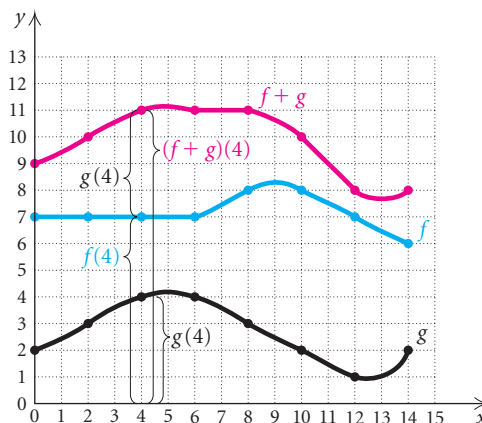

With this in mind, let's view Example 1 from a graphical perspective. Let's look at the graphs of

$$f(x) = x + 1, \quad g(x) = \sqrt{x + 3}, \quad \text{and} \\ (f + g)(x) = x + 1 + \sqrt{x + 3}.$$

See the graph at left. Note that the domain of f is the set of all real numbers. The domain of g is $[-3, \infty)$. The domain of $f + g$ is the set of numbers in the intersection of the domains. This is the set of numbers in both domains.

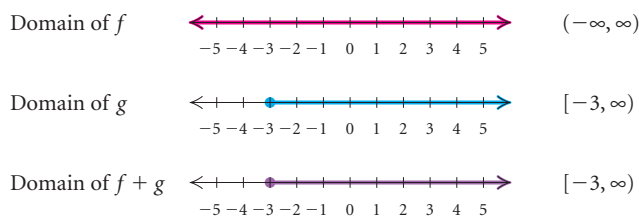

Thus the domain of $f + g$ is $[-3, \infty)$.

We can confirm that the y -coordinates of the graph of $(f + g)(x)$ are the sums of the corresponding y -coordinates of the graphs of $f(x)$ and $g(x)$. Here we confirm it for $x = 2$.

$$\begin{aligned} f(x) &= x + 1 & g(x) &= \sqrt{x + 3} \\ f(2) &= 2 + 1 = 3; & g(2) &= \sqrt{2 + 3} = \sqrt{5}; \\ (f + g)(x) &= x + 1 + \sqrt{x + 3} \\ (f + g)(2) &= 2 + 1 + \sqrt{2 + 3} \\ &= 3 + \sqrt{5} = f(2) + g(2) \end{aligned}$$

Let's also examine the domains of $f - g$, fg , and f/g for the functions $f(x) = x + 1$ and $g(x) = \sqrt{x + 3}$ of Example 1. The domains of $f - g$ and fg are the same as the domain of $f + g$, $[-3, \infty)$, because numbers in this interval are in the domains of *both* functions. For f/g , $g(x)$ cannot be 0. Since $\sqrt{x + 3} = 0$ when $x = -3$, we must exclude -3 and the domain of f/g is $(-3, \infty)$.

Domains of $f + g$, $f - g$, fg , and f/g

If f and g are functions, then the domain of the functions $f + g$, $f - g$, and fg is the intersection of the domain of f and the domain of g . The domain of f/g is also the intersection of the domains of f and g with the exclusion of any x -values for which $g(x) = 0$.

EXAMPLE 2 Given that $f(x) = x^2 - 4$ and $g(x) = x + 2$, find each of the following.

- a) The domain of $f + g$, $f - g$, fg , and f/g
 b) $(f + g)(x)$ c) $(f - g)(x)$
 d) $(fg)(x)$ e) $(f/g)(x)$
 f) $(gg)(x)$

Solution

a) The domain of f is the set of all real numbers. The domain of g is also the set of all real numbers. The domains of $f + g$, $f - g$, and fg are the set of numbers in the intersection of the domains—that is, the set of numbers in both domains, which is again the set of real numbers. For f/g , we must exclude -2 , since $g(-2) = 0$. Thus the domain of f/g is the set of real numbers excluding -2 , or $(-\infty, -2) \cup (-2, \infty)$.

b) $(f + g)(x) = f(x) + g(x) = (x^2 - 4) + (x + 2) = x^2 + x - 2$

c) $(f - g)(x) = f(x) - g(x) = (x^2 - 4) - (x + 2) = x^2 - x - 6$

d) $(fg)(x) = f(x) \cdot g(x) = (x^2 - 4)(x + 2) = x^3 + 2x^2 - 4x - 8$

e) $(f/g)(x) = \frac{f(x)}{g(x)}$
 $= \frac{x^2 - 4}{x + 2}$ **Note that $g(x) = 0$ when $x = -2$, so $(f/g)(x)$ is not defined when $x = -2$.**
 $= \frac{(x + 2)(x - 2)}{x + 2}$ **Factoring**
 $= x - 2$ **Removing a factor of 1: $\frac{x + 2}{x + 2} = 1$**

Thus, $(f/g)(x) = x - 2$ with the added stipulation that $x \neq -2$ since -2 is not in the domain of $(f/g)(x)$.

f) $(gg)(x) = g(x) \cdot g(x) = [g(x)]^2 = (x + 2)^2 = x^2 + 4x + 4$

► Difference Quotients

In Section 1.3, we learned that the slope of a line can be considered as an average *rate of change*. Here let's consider a nonlinear function f and draw a line through two points $(x, f(x))$ and $(x + h, f(x + h))$ as shown below.

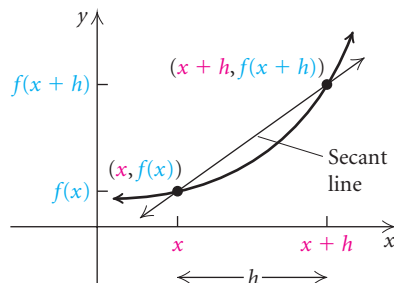

The slope of the line, called a **secant line**, is

$$\frac{f(x + h) - f(x)}{x + h - x},$$

which simplifies to

$$\frac{f(x + h) - f(x)}{h}. \quad \text{Difference quotient}$$

This ratio is called the **difference quotient**, or the **average rate of change**. In calculus, it is important to be able to find and simplify difference quotients.

EXAMPLE 3 For the function f given by $f(x) = 2x - 3$, find and simplify the difference quotient

$$\frac{f(x + h) - f(x)}{h}.$$

Solution

$$\begin{aligned} \frac{f(x + h) - f(x)}{h} &= \frac{2(x + h) - 3 - (2x - 3)}{h} && \text{Substituting} \\ &= \frac{2x + 2h - 3 - 2x + 3}{h} && \text{Removing} \\ &= \frac{2h}{h} && \text{parentheses} \\ &= 2 && \text{Simplifying} \end{aligned}$$

➔ Now Try Exercise 47.

EXAMPLE 4 For the function f given by $f(x) = \frac{1}{x}$, find and simplify the difference quotient

$$\frac{f(x + h) - f(x)}{h}.$$

Solution

$$\begin{aligned}
 \frac{f(x+h) - f(x)}{h} &= \frac{\frac{1}{x+h} - \frac{1}{x}}{h} && \text{Substituting} \\
 &= \frac{\frac{1}{x+h} \cdot \frac{x}{x} - \frac{1}{x} \cdot \frac{x+h}{x+h}}{h} && \text{The LCD of } \frac{1}{x+h} \\
 & && \text{and } \frac{1}{x} \text{ is } x(x+h). \\
 &= \frac{\frac{x}{x(x+h)} - \frac{x+h}{x(x+h)}}{h} \\
 &= \frac{x - (x+h)}{x(x+h)} && \text{Subtracting in the numerator} \\
 &= \frac{x - x - h}{x(x+h)} && \text{Removing parentheses} \\
 &= \frac{-h}{x(x+h)} && \text{Simplifying the numerator} \\
 &= \frac{-h}{x(x+h)} \cdot \frac{1}{h} && \text{Multiplying by the reciprocal} \\
 & && \text{of the divisor} \\
 &= \frac{-h \cdot 1}{x \cdot (x+h) \cdot h} \\
 &= \frac{-1 \cdot h}{x \cdot (x+h) \cdot h} && \text{Simplifying} \\
 &= \frac{-1}{x(x+h)}, \text{ or } -\frac{1}{x(x+h)}
 \end{aligned}$$

 **Now Try Exercise 53.**

EXAMPLE 5 For the function f given by $f(x) = 2x^2 - x - 3$, find and simplify the difference quotient

$$\frac{f(x+h) - f(x)}{h}$$

Solution We first find $f(x+h)$:

$$\begin{aligned}
 f(x+h) &= 2(x+h)^2 - (x+h) - 3 && \text{Substituting } x+h \text{ for } x \\
 & && \text{in } f(x) = 2x^2 - x - 3 \\
 &= 2[x^2 + 2xh + h^2] - (x+h) - 3 \\
 &= 2x^2 + 4xh + 2h^2 - x - h - 3.
 \end{aligned}$$

Then

$$\begin{aligned} \frac{f(x+h) - f(x)}{h} &= \frac{[2x^2 + 4xh + 2h^2 - x - h - 3] - [2x^2 - x - 3]}{h} \\ &= \frac{2x^2 + 4xh + 2h^2 - x - h - 3 - 2x^2 + x + 3}{h} \\ &= \frac{4xh + 2h^2 - h}{h} \\ &= \frac{h(4x + 2h - 1)}{h \cdot 1} = \frac{h}{h} \cdot \frac{4x + 2h - 1}{1} = 4x + 2h - 1. \end{aligned}$$

 **Now Try Exercise 61.**

2.2

Exercise Set

Given that $f(x) = x^2 - 3$ and $g(x) = 2x + 1$, find each of the following, if it exists.

1. $(f + g)(5)$
2. $(fg)(0)$
3. $(f - g)(-1)$
4. $(fg)(2)$
5. $(f/g)(-\frac{1}{2})$
6. $(f - g)(0)$
7. $(fg)(-\frac{1}{2})$
8. $(f/g)(-\sqrt{3})$
9. $(g - f)(-1)$
10. $(g/f)(-\frac{1}{2})$

Given that $h(x) = x + 4$ and $g(x) = \sqrt{x - 1}$, find each of the following, if it exists.

11. $(h - g)(-4)$
12. $(gh)(10)$
13. $(g/h)(1)$
14. $(h/g)(1)$
15. $(g + h)(1)$
16. $(hg)(3)$

For each pair of functions in Exercises 17–32:

- a) Find the domain of f , g , $f + g$, $f - g$, fg , ff , f/g , and g/f .
- b) Find $(f + g)(x)$, $(f - g)(x)$, $(fg)(x)$, $(ff)(x)$, $(f/g)(x)$, and $(g/f)(x)$.

17. $f(x) = 2x + 3$, $g(x) = 3 - 5x$
18. $f(x) = -x + 1$, $g(x) = 4x - 2$
19. $f(x) = x - 3$, $g(x) = \sqrt{x + 4}$
20. $f(x) = x + 2$, $g(x) = \sqrt{x - 1}$
21. $f(x) = 2x - 1$, $g(x) = -2x^2$
22. $f(x) = x^2 - 1$, $g(x) = 2x + 5$
23. $f(x) = \sqrt{x - 3}$, $g(x) = \sqrt{x + 3}$

24. $f(x) = \sqrt{x}$, $g(x) = \sqrt{2 - x}$
25. $f(x) = x + 1$, $g(x) = |x|$
26. $f(x) = 4|x|$, $g(x) = 1 - x$
27. $f(x) = x^3$, $g(x) = 2x^2 + 5x - 3$
28. $f(x) = x^2 - 4$, $g(x) = x^3$
29. $f(x) = \frac{4}{x + 1}$, $g(x) = \frac{1}{6 - x}$
30. $f(x) = 2x^2$, $g(x) = \frac{2}{x - 5}$
31. $f(x) = \frac{1}{x}$, $g(x) = x - 3$
32. $f(x) = \sqrt{x + 6}$, $g(x) = \frac{1}{x}$

In Exercises 33–38, consider the functions F and G as shown in the following graph.

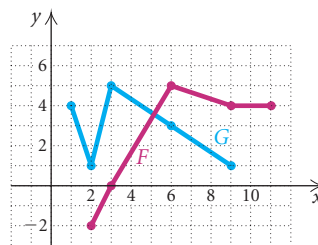

33. Find the domain of F , the domain of G , and the domain of $F + G$.
34. Find the domain of $F - G$, FG , and F/G .

35. Find the domain of G/F .
36. Graph $F + G$.
37. Graph $G - F$.
38. Graph $F - G$.

In Exercises 39–44, consider the functions F and G as shown in the following graph.

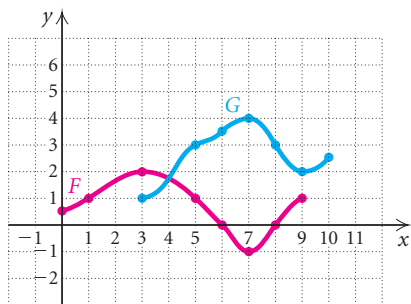

39. Find the domain of F , the domain of G , and the domain of $F + G$.
40. Find the domain of $F - G$, FG , and F/G .
41. Find the domain of G/F .
42. Graph $F + G$.
43. Graph $G - F$.
44. Graph $F - G$.
45. **Total Cost, Revenue, and Profit.** In economics, functions that involve revenue, cost, and profit are used. For example, suppose that $R(x)$ and $C(x)$ denote the total revenue and the total cost, respectively, of producing a new kind of tool for King Hardware Wholesalers. Then the difference $P(x) = R(x) - C(x)$ represents the total profit for producing x tools. Given $R(x) = 60x - 0.4x^2$ and $C(x) = 3x + 13$, find each of the following.
- $P(x)$
 - $R(100)$, $C(100)$, and $P(100)$
46. **Total Cost, Revenue, and Profit.** Given that $R(x) = 200x - x^2$ and $C(x) = 5000 + 8x$, for a new radio produced by Clear Communication, find each of the following. (See Exercise 45.)
- $P(x)$
 - $R(175)$, $C(175)$, and $P(175)$

For each function f , construct and simplify the difference quotient

$$\frac{f(x+h) - f(x)}{h}$$

47. $f(x) = 3x - 5$
48. $f(x) = 4x - 1$
49. $f(x) = 6x + 2$
50. $f(x) = 5x + 3$
51. $f(x) = \frac{1}{3}x + 1$
52. $f(x) = -\frac{1}{2}x + 7$
53. $f(x) = \frac{1}{3x}$
54. $f(x) = \frac{1}{2x}$
55. $f(x) = -\frac{1}{4x}$
56. $f(x) = -\frac{1}{x}$
57. $f(x) = x^2 + 1$
58. $f(x) = x^2 - 3$
59. $f(x) = 4 - x^2$
60. $f(x) = 2 - x^2$
61. $f(x) = 3x^2 - 2x + 1$
62. $f(x) = 5x^2 + 4x$
63. $f(x) = 4 + 5|x|$
64. $f(x) = 2|x| + 3x$
65. $f(x) = x^3$
66. $f(x) = x^3 - 2x$
67. $f(x) = \frac{x-4}{x+3}$
68. $f(x) = \frac{x}{2-x}$

Skill Maintenance

Graph the equation.

69. $y = 3x - 1$
70. $2x + y = 4$
71. $x - 3y = 3$
72. $y = x^2 + 1$

Synthesis

73. Write equations for two functions f and g such that the domain of $f - g$ is $\{x \mid x \neq -7 \text{ and } x \neq 3\}$.
74. For functions h and f , find the domain of $h + f$, $h - f$, hf , and h/f if $h = \{(-4, 13), (-1, 7), (0, 5), (\frac{5}{2}, 0), (3, -5)\}$, and $f = \{(-4, -7), (-2, -5), (0, -3), (3, 0), (5, 2), (9, 6)\}$.
75. Find the domain of $(h/g)(x)$ given that $h(x) = \frac{5x}{3x-7}$ and $g(x) = \frac{x^4-1}{5x-15}$.

The Composition of Functions

2.3

- ▶ Find the composition of two functions and the domain of the composition.
- ▶ Decompose a function as a composition of two functions.



▶ The Composition of Functions

In real-world situations, it is not uncommon for the output of a function to depend on some input that is itself an output of another function. For instance, the amount that a person pays as state income tax usually depends on the amount of adjusted gross income on the person's federal tax return, which, in turn, depends on his or her annual earnings. Such functions are called **composite functions**.

To see how composite functions work, suppose a chemistry student needs a formula to convert Fahrenheit temperatures to Kelvin units. The formula

$$c(t) = \frac{5}{9}(t - 32)$$

gives the Celsius temperature $c(t)$ that corresponds to the Fahrenheit temperature t . The formula

$$k(c(t)) = c(t) + 273$$

gives the Kelvin temperature $k(c(t))$ that corresponds to the Celsius temperature $c(t)$. Thus, 50° Fahrenheit corresponds to

$$c(50) = \frac{5}{9}(50 - 32) = \frac{5}{9}(18) = 10^\circ \text{ Celsius}$$

and 10° Celsius corresponds to

$$k(c(50)) = k(10) = 10 + 273 = 283 \text{ Kelvin units,}$$

which is usually written 283 K. We see that 50° Fahrenheit is the same as 283 K. This two-step procedure can be used to convert any Fahrenheit temperature to Kelvin units.

TECHNOLOGY CONNECTION

With the TABLE feature, we can convert Fahrenheit temperatures, x , to Celsius temperatures, y_1 , using

$$y_1 = \frac{5}{9}(x - 32).$$

We can also convert Celsius temperatures y_1 to Kelvin units, y_2 using

$$y_2 = y_1 + 273.$$

$$y_1 = \frac{5}{9}(x - 32), \quad y_2 = y_1 + 273$$

X	Y ₁	Y ₂
50	10	283
59	15	288
68	20	293
77	25	298
86	30	303
95	35	308
104	40	313
X = 50		

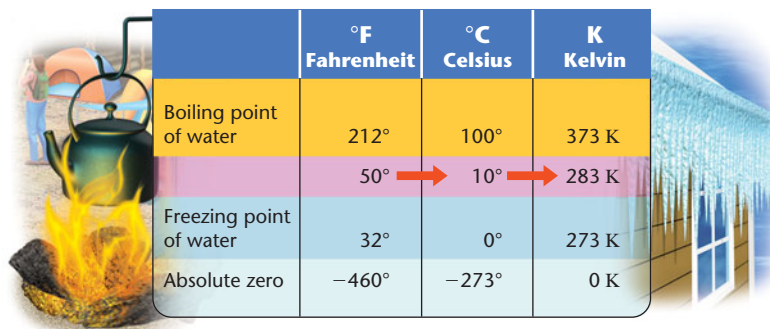

A student making numerous conversions might look for a formula that converts directly from Fahrenheit to Kelvin. Such a formula can be found by substitution:

$$\begin{aligned}
 k(c(t)) &= c(t) + 273 \\
 &= \frac{5}{9}(t - 32) + 273 && \text{Substituting } \frac{5}{9}(t - 32) \text{ for } c(t) \\
 &= \frac{5}{9}t - \frac{160}{9} + 273 \\
 &= \frac{5}{9}t - \frac{160}{9} + \frac{2457}{9} \\
 &= \frac{5t + 2297}{9}. && \text{Simplifying}
 \end{aligned}$$

Since the formula found above expresses the Kelvin temperature as a new function K of the Fahrenheit temperature t , we can write

$$K(t) = \frac{5t + 2297}{9},$$

where $K(t)$ is the Kelvin temperature corresponding to the Fahrenheit temperature, t . Here we have $K(t) = k(c(t))$. The new function K is called the **composition** of k and c and can be denoted $k \circ c$ (read “ k composed with c ,” “the composition of k and c ,” or “ k circle c ”).

Composition of Functions

The **composite function** $f \circ g$, the **composition** of f and g , is defined as

$$(f \circ g)(x) = f(g(x)),$$

where x is in the domain of g and $g(x)$ is in the domain of f .

EXAMPLE 1 Given that $f(x) = 2x - 5$ and $g(x) = x^2 - 3x + 8$, find each of the following.

- a) $(f \circ g)(x)$ and $(g \circ f)(x)$ b) $(f \circ g)(7)$ and $(g \circ f)(7)$
 c) $(g \circ g)(1)$ d) $(f \circ f)(x)$

Solution Consider each function separately:

$$f(x) = 2x - 5 \quad \text{This function multiplies each input by 2 and then subtracts 5.}$$

and

$$g(x) = x^2 - 3x + 8. \quad \text{This function squares an input, subtracts three times the input from the result, and then adds 8.}$$

- a) To find $(f \circ g)(x)$, we substitute $g(x)$ for x in the equation for $f(x)$:

$$\begin{aligned}(f \circ g)(x) &= f(g(x)) = f(x^2 - 3x + 8) \\ &= 2(x^2 - 3x + 8) - 5 \\ &= 2x^2 - 6x + 16 - 5 \\ &= 2x^2 - 6x + 11.\end{aligned}$$

$x^2 - 3x + 8$ is the input for f . f multiplies the input by 2 and then subtracts 5.

To find $(g \circ f)(x)$, we substitute $f(x)$ for x in the equation for $g(x)$:

$$\begin{aligned}(g \circ f)(x) &= g(f(x)) = g(2x - 5) \\ &= (2x - 5)^2 - 3(2x - 5) + 8\end{aligned}$$

$2x - 5$ is the input for g . g squares the input, subtracts three times the input, and then adds 8.

$$\begin{aligned}&= 4x^2 - 20x + 25 - 6x + 15 + 8 \\ &= 4x^2 - 26x + 48.\end{aligned}$$

- b) To find $(f \circ g)(7)$, we first find $g(7)$. Then we use $g(7)$ as an input for f :

$$\begin{aligned}(f \circ g)(7) &= f(g(7)) = f(7^2 - 3 \cdot 7 + 8) \\ &= f(36) = 2 \cdot 36 - 5 \\ &= 67.\end{aligned}$$

To find $(g \circ f)(7)$, we first find $f(7)$. Then we use $f(7)$ as an input for g :

$$\begin{aligned}(g \circ f)(7) &= g(f(7)) = g(2 \cdot 7 - 5) \\ &= g(9) = 9^2 - 3 \cdot 9 + 8 \\ &= 62.\end{aligned}$$

We could also find $(f \circ g)(7)$ and $(g \circ f)(7)$ by substituting 7 for x in the equations that we found in part (a):

$$\begin{aligned}(f \circ g)(x) &= 2x^2 - 6x + 11 \\ (f \circ g)(7) &= 2 \cdot 7^2 - 6 \cdot 7 + 11 = 67; \\ (g \circ f)(x) &= 4x^2 - 26x + 48 \\ (g \circ f)(7) &= 4 \cdot 7^2 - 26 \cdot 7 + 48 = 62.\end{aligned}$$

- c) $(g \circ g)(1) = g(g(1)) = g(1^2 - 3 \cdot 1 + 8)$
 $= g(1 - 3 + 8) = g(6)$
 $= 6^2 - 3 \cdot 6 + 8$
 $= 36 - 18 + 8 = 26$

- d) $(f \circ f)(x) = f(f(x)) = f(2x - 5)$
 $= 2(2x - 5) - 5$
 $= 4x - 10 - 5 = 4x - 15$

TECHNOLOGY CONNECTION

We can check our work in Example 1(b) using a graphing calculator. We enter the following on the equation-editor screen:

$$y_1 = 2x - 5$$

and

$$y_2 = x^2 - 3x + 8.$$

Then, on the home screen, we find $(f \circ g)(7)$ and $(g \circ f)(7)$ using the function notations $Y_1(Y_2(7))$ and $Y_2(Y_1(7))$, respectively.

$$y_1 = 2x - 5, \quad y_2 = x^2 - 3x + 8$$

$Y_1(Y_2(7))$	67
$Y_2(Y_1(7))$	62

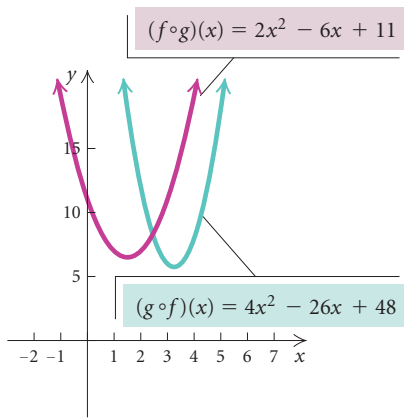

Example 1 illustrates that, as a rule, $(f \circ g)(x) \neq (g \circ f)(x)$. We can see this graphically, as shown in the graphs at left.

EXAMPLE 2 Given that $f(x) = \sqrt{x}$ and $g(x) = x - 3$:

- Find $f \circ g$ and $g \circ f$.
- Find the domain of $f \circ g$ and the domain of $g \circ f$.

Solution

$$\begin{aligned} \text{a) } (f \circ g)(x) &= f(g(x)) = f(x - 3) = \sqrt{x - 3} \\ (g \circ f)(x) &= g(f(x)) = g(\sqrt{x}) = \sqrt{x} - 3 \end{aligned}$$

- Since $f(x)$ is not defined for negative radicands, the domain of $f(x)$ is $\{x \mid x \geq 0\}$, or $[0, \infty)$. Any real number can be an input for $g(x)$, so the domain of $g(x)$ is $(-\infty, \infty)$.

Since the inputs of $f \circ g$ are outputs of g , the domain of $f \circ g$ consists of the values of x in the domain of g , $(-\infty, \infty)$, for which $g(x)$ is nonnegative. (Recall that the inputs of $f(x)$ must be nonnegative.)

Thus we have

$$\begin{aligned} g(x) &\geq 0 \\ x - 3 &\geq 0 && \text{Substituting } x - 3 \text{ for } g(x) \\ x &\geq 3. \end{aligned}$$

We see that the domain of $f \circ g$ is $\{x \mid x \geq 3\}$, or $[3, \infty)$.

We can also find the domain of $f \circ g$ by examining the composite function itself, $(f \circ g)(x) = \sqrt{x - 3}$. Since any real number can be an input for g , the only restriction on $f \circ g$ is that the radicand must be nonnegative. We have

$$\begin{aligned} x - 3 &\geq 0 \\ x &\geq 3. \end{aligned}$$

Again, we see that the domain of $f \circ g$ is $\{x \mid x \geq 3\}$, or $[3, \infty)$. The graph in Fig. 1 confirms this.

The inputs of $g \circ f$ are outputs of f , so the domain of $g \circ f$ consists of the values of x in the domain of f , $[0, \infty)$, for which $g(x)$ is defined. Since g can accept *any* real number as an input, any output from f is acceptable, so the entire domain of f is the domain of $g \circ f$. That is, the domain of $g \circ f$ is $\{x \mid x \geq 0\}$, or $[0, \infty)$.

We can also examine the composite function itself to find its domain. First recall that the domain of f is $\{x \mid x \geq 0\}$, or $[0, \infty)$. Then consider $(g \circ f)(x) = \sqrt{x} - 3$. The radicand cannot be negative, so we have $x \geq 0$. As above, we see that the domain of $g \circ f$ is the domain of f , $\{x \mid x \geq 0\}$, or $[0, \infty)$. The graph in Fig. 2 confirms this.

Now Try Exercise 27.

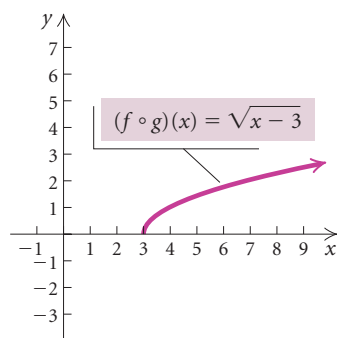

Figure 1

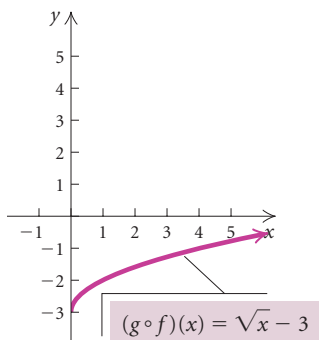

Figure 2

EXAMPLE 3 Given that $f(x) = \frac{1}{x - 2}$ and $g(x) = \frac{5}{x}$, find $f \circ g$ and $g \circ f$ and the domain of each.

Solution We have

$$(f \circ g)(x) = f(g(x)) = f\left(\frac{5}{x}\right) = \frac{1}{\frac{5}{x} - 2} = \frac{1}{\frac{5 - 2x}{x}} = \frac{x}{5 - 2x};$$

$$(g \circ f)(x) = g(f(x)) = g\left(\frac{1}{x - 2}\right) = \frac{5}{\frac{1}{x - 2}} = 5(x - 2).$$

Values of x that make the denominator 0 are not in the domains of these functions. Since $x - 2 = 0$ when $x = 2$, the domain of f is $\{x \mid x \neq 2\}$. The denominator of g is x , so the domain of g is $\{x \mid x \neq 0\}$.

The inputs of $f \circ g$ are outputs of g , so the domain of $f \circ g$ consists of the values of x in the domain of g for which $g(x) \neq 2$. (Recall that 2 cannot be an input of f .) Since the domain of g is $\{x \mid x \neq 0\}$, 0 is not in the domain of $f \circ g$. In addition, we must find the value(s) of x for which $g(x) = 2$. We have

$$\begin{aligned} g(x) &= 2 \\ \frac{5}{x} &= 2 && \text{Substituting } \frac{5}{x} \text{ for } g(x) \\ 5 &= 2x \\ \frac{5}{2} &= x. \end{aligned}$$

This tells us that $\frac{5}{2}$ is also *not* in the domain of $f \circ g$. Then the domain of $f \circ g$ is $\{x \mid x \neq 0 \text{ and } x \neq \frac{5}{2}\}$, or $(-\infty, 0) \cup (0, \frac{5}{2}) \cup (\frac{5}{2}, \infty)$.

We can also examine the composite function $f \circ g$ to find its domain. First, recall that 0 is not in the domain of g , so it cannot be in the domain of $(f \circ g)(x) = x/(5 - 2x)$. We must also exclude the value(s) of x for which the denominator of $f \circ g$ is 0. We have

$$\begin{aligned} 5 - 2x &= 0 \\ 5 &= 2x \\ \frac{5}{2} &= x. \end{aligned}$$

Again, we see that $\frac{5}{2}$ is also not in the domain, so the domain of $f \circ g$ is $\{x \mid x \neq 0 \text{ and } x \neq \frac{5}{2}\}$, or $(-\infty, 0) \cup (0, \frac{5}{2}) \cup (\frac{5}{2}, \infty)$.

Since the inputs of $g \circ f$ are outputs of f , the domain of $g \circ f$ consists of the values of x in the domain of f for which $f(x) \neq 0$. (Recall that 0 cannot be an input of g .) The domain of f is $\{x \mid x \neq 2\}$, so 2 is not in the domain of $g \circ f$. Next, we determine whether there are values of x for which $f(x) = 0$:

$$\begin{aligned} f(x) &= 0 \\ \frac{1}{x - 2} &= 0 && \text{Substituting } \frac{1}{x - 2} \text{ for } f(x) \\ (x - 2) \cdot \frac{1}{x - 2} &= (x - 2) \cdot 0 && \text{Multiplying by } x - 2 \\ 1 &= 0. && \text{False equation} \end{aligned}$$

We see that there are no values of x for which $f(x) = 0$, so there are no additional restrictions on the domain of $g \circ f$. Thus the domain of $g \circ f$ is $\{x \mid x \neq 2\}$, or $(-\infty, 2) \cup (2, \infty)$.

We can also examine $g \circ f$ to find its domain. First, recall that 2 is not in the domain of f , so it cannot be in the domain of $(g \circ f)(x) = 5(x - 2)$. Since $5(x - 2)$ is defined for all real numbers, there are no additional restrictions on the domain of $g \circ f$. The domain is $\{x \mid x \neq 2\}$, or $(-\infty, 2) \cup (2, \infty)$.

 **Now Try Exercise 23.**

► Decomposing a Function as a Composition

In calculus, one often needs to recognize how a function can be expressed as the composition of two functions. In this way, we are “decomposing” the function.

EXAMPLE 4 If $h(x) = (2x - 3)^5$, find $f(x)$ and $g(x)$ such that $h(x) = (f \circ g)(x)$.

Solution The function $h(x)$ raises $(2x - 3)$ to the 5th power. Two functions that can be used for the composition are

$$f(x) = x^5 \quad \text{and} \quad g(x) = 2x - 3.$$

We can check by forming the composition:

$$h(x) = (f \circ g)(x) = f(g(x)) = f(2x - 3) = (2x - 3)^5.$$

This is the most “obvious” solution. There can be other less obvious solutions. For example, if

$$f(x) = (x + 7)^5 \quad \text{and} \quad g(x) = 2x - 10,$$

then

$$\begin{aligned} h(x) &= (f \circ g)(x) = f(g(x)) \\ &= f(2x - 10) \\ &= [2x - 10 + 7]^5 = (2x - 3)^5. \end{aligned}$$

 **Now Try Exercise 39.**

EXAMPLE 5 If $h(x) = \frac{1}{(x + 3)^3}$, find $f(x)$ and $g(x)$ such that $h(x) = (f \circ g)(x)$.

Solution Two functions that can be used are

$$f(x) = \frac{1}{x} \quad \text{and} \quad g(x) = (x + 3)^3.$$

We check by forming the composition:

$$h(x) = (f \circ g)(x) = f(g(x)) = f((x + 3)^3) = \frac{1}{(x + 3)^3}.$$

There are other functions that can be used as well. For example, if

$$f(x) = \frac{1}{x^3} \quad \text{and} \quad g(x) = x + 3,$$

then

$$h(x) = (f \circ g)(x) = f(g(x)) = f(x + 3) = \frac{1}{(x + 3)^3}.$$

 **Now Try Exercise 41.**

2.3

Exercise Set

Given that $f(x) = 3x + 1$, $g(x) = x^2 - 2x - 6$, and $h(x) = x^3$, find each of the following.

1. $(f \circ g)(-1)$
2. $(g \circ f)(-2)$
3. $(h \circ f)(1)$
4. $(g \circ h)(\frac{1}{2})$
5. $(g \circ f)(5)$
6. $(f \circ g)(\frac{1}{3})$
7. $(f \circ h)(-3)$
8. $(h \circ g)(3)$
9. $(g \circ g)(-2)$
10. $(g \circ g)(3)$
11. $(h \circ h)(2)$
12. $(h \circ h)(-1)$
13. $(f \circ f)(-4)$
14. $(f \circ f)(1)$
15. $(h \circ h)(x)$
16. $(f \circ f)(x)$

Find $(f \circ g)(x)$ and $(g \circ f)(x)$ and the domain of each.

17. $f(x) = x + 3$, $g(x) = x - 3$
18. $f(x) = \frac{4}{5}x$, $g(x) = \frac{5}{4}x$
19. $f(x) = x + 1$, $g(x) = 3x^2 - 2x - 1$
20. $f(x) = 3x - 2$, $g(x) = x^2 + 5$
21. $f(x) = x^2 - 3$, $g(x) = 4x - 3$
22. $f(x) = 4x^2 - x + 10$, $g(x) = 2x - 7$
23. $f(x) = \frac{4}{1 - 5x}$, $g(x) = \frac{1}{x}$
24. $f(x) = \frac{6}{x}$, $g(x) = \frac{1}{2x + 1}$
25. $f(x) = 3x - 7$, $g(x) = \frac{x + 7}{3}$
26. $f(x) = \frac{2}{3}x - \frac{4}{5}$, $g(x) = 1.5x + 1.2$
27. $f(x) = 2x + 1$, $g(x) = \sqrt{x}$
28. $f(x) = \sqrt{x}$, $g(x) = 2 - 3x$
29. $f(x) = 20$, $g(x) = 0.05$
30. $f(x) = x^4$, $g(x) = \sqrt[4]{x}$

31. $f(x) = \sqrt{x + 5}$, $g(x) = x^2 - 5$
32. $f(x) = x^5 - 2$, $g(x) = \sqrt[5]{x + 2}$
33. $f(x) = x^2 + 2$, $g(x) = \sqrt{3 - x}$
34. $f(x) = 1 - x^2$, $g(x) = \sqrt{x^2 - 25}$
35. $f(x) = \frac{1 - x}{x}$, $g(x) = \frac{1}{1 + x}$
36. $f(x) = \frac{1}{x - 2}$, $g(x) = \frac{x + 2}{x}$

37. $f(x) = x^3 - 5x^2 + 3x + 7$, $g(x) = x + 1$
38. $f(x) = x - 1$, $g(x) = x^3 + 2x^2 - 3x - 9$

Find $f(x)$ and $g(x)$ such that $h(x) = (f \circ g)(x)$. Answers may vary.

39. $h(x) = (4 + 3x)^5$
40. $h(x) = \sqrt[3]{x^2 - 8}$
41. $h(x) = \frac{1}{(x - 2)^4}$
42. $h(x) = \frac{1}{\sqrt{3x + 7}}$
43. $h(x) = \frac{x^3 - 1}{x^3 + 1}$
44. $h(x) = |9x^2 - 4|$
45. $h(x) = \left(\frac{2 + x^3}{2 - x^3}\right)^6$
46. $h(x) = (\sqrt{x} - 3)^4$
47. $h(x) = \sqrt{\frac{x - 5}{x + 2}}$
48. $h(x) = \sqrt{1 + \sqrt{1 + x}}$
49. $h(x) = (x + 2)^3 - 5(x + 2)^2 + 3(x + 2) - 1$
50. $h(x) = 2(x - 1)^{5/3} + 5(x - 1)^{2/3}$

51. **Ripple Spread.** A stone is thrown into a pond, creating a circular ripple that spreads over the pond in such a way that the radius is increasing at a rate of 3 ft/sec.



- Find a function $r(t)$ for the radius in terms of t .
 - Find a function $A(r)$ for the area of the ripple in terms of the radius r .
 - Find $(A \circ r)(t)$. Explain the meaning of this function.
52. The surface area S of a right circular cylinder is given by the formula $S = 2\pi rh + 2\pi r^2$. If the height is twice the radius, find each of the following.



- A function $S(r)$ for the surface area as a function of r
 - A function $S(h)$ for the surface area as a function of h
53. A manufacturer of tools, selling rechargeable drills to a chain of home improvement stores, charges \$2 more per drill than its manufacturing cost m . The chain then sells each drill for 150% of the price that it paid the manufacturer. Find a

function $P(m)$ for the price at the home improvement stores.



54. **Blouse Sizes.** A blouse that is size x in Japan is size $s(x)$ in the United States, where $s(x) = x - 3$. A blouse that is size x in the United States is size $t(x)$ in Australia, where $t(x) = x + 4$. (Source: www.onlineconversion.com) Find a function that will convert Japanese blouse sizes to Australian blouse sizes.

Skill Maintenance

Consider the following linear equations. Without graphing them, answer the questions on the next page.

- $y = x$
- $y = -5x + 4$
- $y = \frac{2}{3}x + 1$
- $y = -0.1x + 6$
- $y = 3x - 5$
- $y = -x - 1$
- $2x - 3y = 6$
- $6x + 3y = 9$

55. Which, if any, have y -intercept $(0, 1)$?
56. Which, if any, have the same y -intercept?
57. Which slope down from left to right?
58. Which has the steepest slope?
59. Which pass(es) through the origin?
60. Which, if any, have the same slope?
61. Which, if any, are parallel?
62. Which, if any, are perpendicular?

Synthesis

63. Let $p(a)$ represent the number of pounds of grass seed required to seed a lawn with area a . Let $c(s)$ represent the cost of s pounds of grass seed. Which composition makes sense: $(c \circ p)(a)$ or $(p \circ c)(s)$? What does it represent?
64. Write equations of two functions f and g such that $f \circ g = g \circ f = x$. (In Section 5.1, we will study inverse functions. If $f \circ g = g \circ f = x$, functions f and g are *inverses* of each other.)

Mid-Chapter Mixed Review

Determine whether the statement is true or false.

1. $f(c)$ is a relative maximum if $(c, f(c))$ is the highest point in some open interval containing c . [2.1]
2. If f and g are functions, then the domain of the functions $f + g$, $f - g$, fg , and f/g is the intersection of the domain of f and the domain of g . [2.2]
3. In general, $(f \circ g)(x) \neq (g \circ f)(x)$. [2.3]
4. Determine the intervals on which the function is (a) increasing; (b) decreasing; (c) constant. [2.1]
5. Using the graph, determine any relative maxima or minima of the function and the intervals on which the function is increasing or decreasing. [2.1]

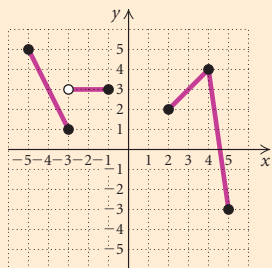

6. Determine the domain and the range of the function graphed in Exercise 4. [2.1]

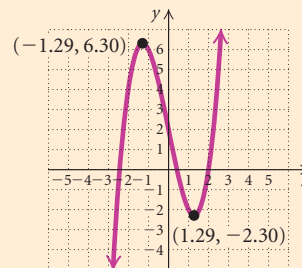

7. **Pendant Design.** Ellen is designing a triangular pendant so that the length of the base is 2 less than the height h . Express the area of the pendant as a function of the height. [2.1]

8. For the function defined as

$$f(x) = \begin{cases} x - 5, & \text{for } x \leq -3, \\ 2x + 3, & \text{for } -3 < x \leq 0, \\ \frac{1}{2}x, & \text{for } x > 0, \end{cases}$$

find $f(-5)$, $f(-3)$, $f(-1)$, and $f(6)$. [2.1]

9. Graph the function defined as

$$g(x) = \begin{cases} x + 2, & \text{for } x < -4, \\ -x, & \text{for } x \geq -4. \end{cases} \quad [2.1]$$

Given that $f(x) = 3x - 1$ and $g(x) = x^2 + 4$, find each of the following, if it exists. [2.2]

10. $(f + g)(-1)$

11. $(fg)(0)$

12. $(g - f)(3)$

13. $(g/f)(\frac{1}{3})$

For each pair of functions in Exercises 14 and 15:

a) Find the domains of f , g , $f + g$, $f - g$, fg , ff , f/g , and g/f .

b) Find $(f + g)(x)$, $(f - g)(x)$, $(fg)(x)$, $(ff)(x)$, $(f/g)(x)$, and $(g/f)(x)$. [2.2]

14. $f(x) = 2x + 5$, $g(x) = -x - 4$

15. $f(x) = x - 1$; $g(x) = \sqrt{x + 2}$

For each function f , construct and simplify the difference quotient

$$\frac{f(x + h) - f(x)}{h}. \quad [2.2]$$

16. $f(x) = 4x - 3$

17. $f(x) = 6 - x^2$

Given that $f(x) = 5x - 4$, $g(x) = x^3 + 1$, and $h(x) = x^2 - 2x + 3$, find each of the following. [2.3]

18. $(f \circ g)(1)$

19. $(g \circ h)(2)$

20. $(f \circ f)(0)$

21. $(h \circ f)(-1)$

Find $(f \circ g)(x)$ and $(g \circ f)(x)$ and the domain of each. [2.3]

22. $f(x) = \frac{1}{2}x$, $g(x) = 6x + 4$

23. $f(x) = 3x + 2$, $g(x) = \sqrt{x}$

Collaborative Discussion and Writing

24. If $g(x) = b$, where b is a positive constant, describe how the graphs of $y = h(x)$ and $y = (h - g)(x)$ will differ. [2.2]

25. If the domain of a function f is the set of real numbers and the domain of a function g is also the set of real numbers, under what circumstances do $(f + g)(x)$ and $(f/g)(x)$ have different domains? [2.2]

26. If f and g are linear functions, what can you say about the domain of $f \circ g$ and the domain of $g \circ f$? [2.3]

27. Nora determines the domain of $f \circ g$ by examining only the formula for $(f \circ g)(x)$. Is her approach valid? Why or why not? [2.3]

Symmetry and Transformations

2.4

- ▶ Determine whether a graph is symmetric with respect to the x -axis, the y -axis, and the origin.
- ▶ Determine whether a function is even, odd, or neither even nor odd.
- ▶ Given the graph of a function, graph its transformation under translations, reflections, stretchings, and shrinkings.

▶ Symmetry

Symmetry occurs often in nature and in art. For example, when viewed from the front, the bodies of most animals are at least approximately symmetric. This means that each eye is the same distance from the center of the bridge of the nose, each shoulder is the same distance from the center of the chest, and so on. Architects have used symmetry for thousands of years to enhance the beauty of buildings.

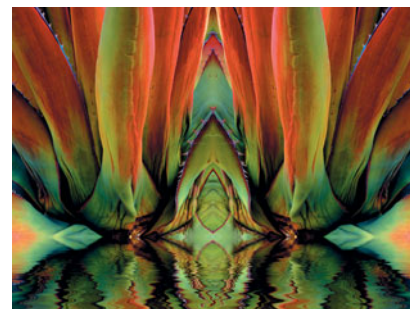
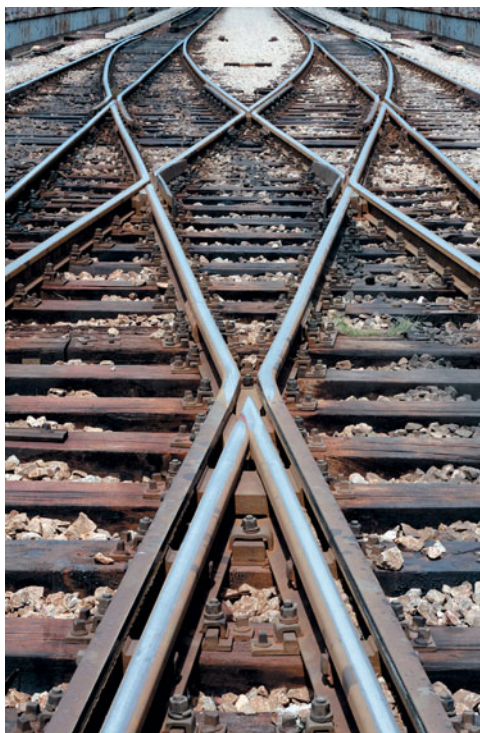
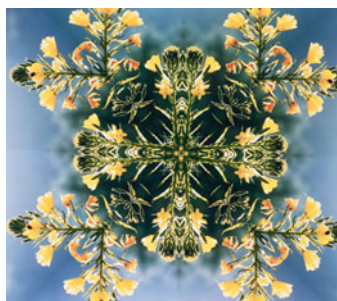

A knowledge of symmetry in mathematics helps us graph and analyze equations and functions.

STUDY TIP

Try to keep one section ahead of your syllabus. If you study ahead of your lectures, you can concentrate on what is being explained in them, rather than trying to write everything down. You can then take notes only on special points or on questions related to what is happening in class.

Consider the points $(4, 2)$ and $(4, -2)$ that appear on the graph of $x = y^2$. (See Fig. 1.) Points like these have the same x -value but opposite y -values and are **reflections** of each other across the x -axis. If, for any point (x, y) on a graph, the point $(x, -y)$ is also on the graph, then the graph is said to be **symmetric with respect to the x -axis**. If we fold the graph on the x -axis, the parts above and below the x -axis will coincide.

Consider the points $(3, 4)$ and $(-3, 4)$ that appear on the graph of $y = x^2 - 5$. (See Fig. 2.) Points like these have the same y -value but opposite x -values and are **reflections** of each other across the y -axis. If, for any point (x, y) on a graph, the point $(-x, y)$ is also on the graph, then the graph is said to be **symmetric with respect to the y -axis**. If we fold the graph on the y -axis, the parts to the left and right of the y -axis will coincide.

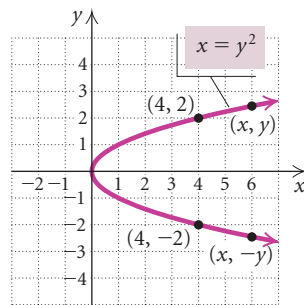

Figure 1

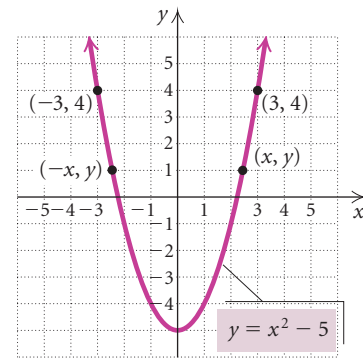

Figure 2

Consider the points $(-3, \sqrt{7})$ and $(3, -\sqrt{7})$ that appear on the graph of $x^2 = y^2 + 2$. (See Fig. 3.) Note that if we take the opposites of the coordinates of one pair, we get the other pair. If, for any point (x, y) on a graph, the point $(-x, -y)$ is also on the graph, then the graph is said to be **symmetric with respect to the origin**. Visually, if we rotate the graph 180° about the origin, the resulting figure coincides with the original.

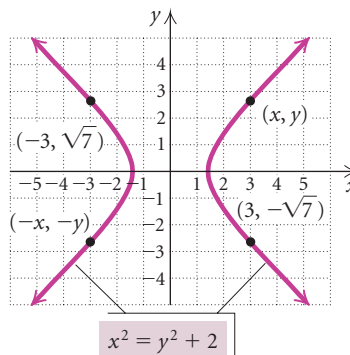

Figure 3

Algebraic Tests of Symmetry

x-axis: If replacing y with $-y$ produces an equivalent equation, then the graph is *symmetric with respect to the x-axis*.

y-axis: If replacing x with $-x$ produces an equivalent equation, then the graph is *symmetric with respect to the y-axis*.

Origin: If replacing x with $-x$ and y with $-y$ produces an equivalent equation, then the graph is *symmetric with respect to the origin*.

EXAMPLE 1 Test $y = x^2 + 2$ for symmetry with respect to the x -axis, the y -axis, and the origin.

Algebraic Solution

***x*-Axis:**

We replace y with $-y$:

$$\begin{aligned} y &= x^2 + 2 \\ \downarrow \\ -y &= x^2 + 2 \\ y &= -x^2 - 2. \end{aligned}$$

Multiplying by -1 on both sides

The resulting equation is *not* equivalent to the original equation, so the graph is *not* symmetric with respect to the x -axis.

***y*-Axis:**

We replace x with $-x$:

$$\begin{aligned} y &= x^2 + 2 \\ &\quad \swarrow \\ y &= (-x)^2 + 2 \\ y &= x^2 + 2. \end{aligned}$$

Simplifying

The resulting equation is equivalent to the original equation, so the graph is symmetric with respect to the y -axis.

Origin:

We replace x with $-x$ and y with $-y$:

$$\begin{aligned} y &= x^2 + 2 \\ \downarrow \quad \swarrow \\ -y &= (-x)^2 + 2 \\ -y &= x^2 + 2 \\ y &= -x^2 - 2. \end{aligned}$$

Simplifying

The resulting equation is *not* equivalent to the original equation, so the graph is *not* symmetric with respect to the origin.

Visualizing the Solution

Let's look at the graph of $y = x^2 + 2$.

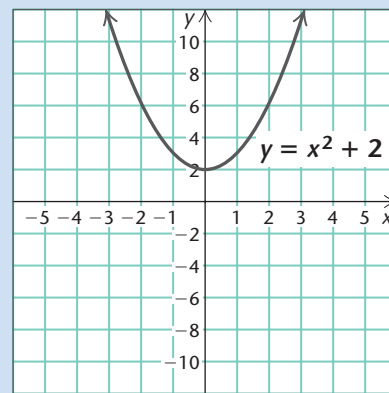

Note that if the graph were folded on the x -axis, the parts above and below the x -axis would not coincide. If it were folded on the y -axis, the parts to the left and right of the y -axis would coincide. If we rotated it 180° about the origin, the resulting graph would not coincide with the original graph.

Thus we see that the graph is *not* symmetric with respect to the x -axis or the origin. The graph is symmetric with respect to the y -axis.

EXAMPLE 2 Test $x^2 + y^4 = 5$ for symmetry with respect to the x -axis, the y -axis, and the origin.

Algebraic Solution

x -Axis:

We replace y with $-y$:

$$\begin{aligned}x^2 + y^4 &= 5 \\x^2 + (-y)^4 &= 5 \\x^2 + y^4 &= 5.\end{aligned}$$

The resulting equation is equivalent to the original equation. Thus the graph is symmetric with respect to the x -axis.

y -Axis:

We replace x with $-x$:

$$\begin{aligned}x^2 + y^4 &= 5 \\(-x)^2 + y^4 &= 5 \\x^2 + y^4 &= 5.\end{aligned}$$

The resulting equation is equivalent to the original equation, so the graph is symmetric with respect to the y -axis.

Origin:

We replace x with $-x$ and y with $-y$:

$$\begin{aligned}x^2 + y^4 &= 5 \\(-x)^2 + (-y)^4 &= 5 \\x^2 + y^4 &= 5.\end{aligned}$$

The resulting equation is equivalent to the original equation, so the graph is symmetric with respect to the origin.

Visualizing the Solution

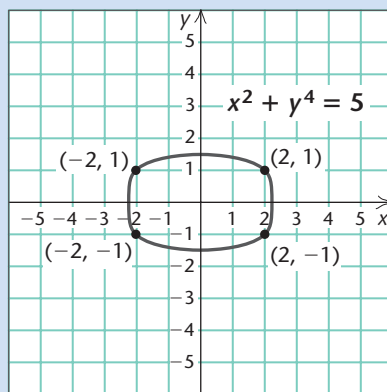

From the graph of the equation, we see symmetry with respect to both axes and with respect to the origin.

➔ Now Try Exercise 21.

Algebraic Procedure for Determining Even Functions and Odd Functions

Given the function $f(x)$:

1. Find $f(-x)$ and simplify. If $f(x) = f(-x)$, then f is even.
2. Find $-f(x)$, simplify, and compare with $f(-x)$ from step (1). If $f(-x) = -f(x)$, then f is odd.

Except for the function $f(x) = 0$, a function cannot be *both* even and odd. Thus if $f(x) \neq 0$ and we see in step (1) that $f(x) = f(-x)$ (that is, f is even), we need not continue.

► Even Functions and Odd Functions

Now we relate symmetry to graphs of functions.

Even Functions and Odd Functions

If the graph of a function f is symmetric with respect to the y -axis, we say that it is an **even function**. That is, for each x in the domain of f , $f(x) = f(-x)$.

If the graph of a function f is symmetric with respect to the origin, we say that it is an **odd function**. That is, for each x in the domain of f , $f(-x) = -f(x)$.

An algebraic procedure for determining even functions and odd functions is shown at left. Below we show an even function and an odd function. Many functions are neither even nor odd.

EXAMPLE 3 Determine whether each of the following functions is even, odd, or neither.

a) $f(x) = 5x^7 - 6x^3 - 2x$

b) $h(x) = 5x^6 - 3x^2 - 7$

a) Algebraic Solution

$$f(x) = 5x^7 - 6x^3 - 2x$$

$$\begin{aligned} 1. \quad f(-x) &= 5(-x)^7 - 6(-x)^3 - 2(-x) \\ &= 5(-x^7) - 6(-x^3) + 2x \\ &\quad (-x)^7 = (-1 \cdot x)^7 = (-1)^7 x^7 = -x^7 \\ &= -5x^7 + 6x^3 + 2x \end{aligned}$$

We see that $f(x) \neq f(-x)$. Thus, f is *not* even.

$$\begin{aligned} 2. \quad -f(x) &= -(5x^7 - 6x^3 - 2x) \\ &= -5x^7 + 6x^3 + 2x \end{aligned}$$

We see that $f(-x) = -f(x)$. Thus, f is odd.

Visualizing the Solution

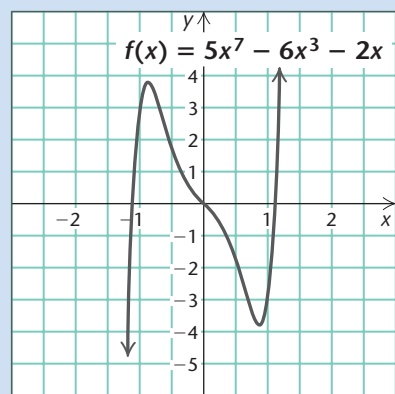

We see that the graph appears to be symmetric with respect to the origin. The function is odd.

b) Algebraic Solution

$$h(x) = 5x^6 - 3x^2 - 7$$

$$\begin{aligned} 1. \ h(-x) &= 5(-x)^6 - 3(-x)^2 - 7 \\ &= 5x^6 - 3x^2 - 7 \end{aligned}$$

We see that $h(x) = h(-x)$. Thus the function is even.

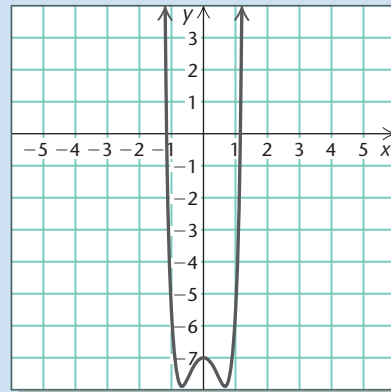
**Visualizing the Solution**

$$h(x) = 5x^6 - 3x^2 - 7$$

We see that the graph appears to be symmetric with respect to the y -axis. The function is even.

➔ Now Try Exercises 39 and 41.

► Transformations of Functions

The graphs of some basic functions are shown below. Others can be seen on the inside back cover.

Identity function:
 $y = x$

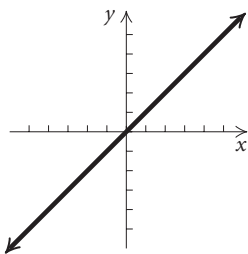

Squaring function:
 $y = x^2$

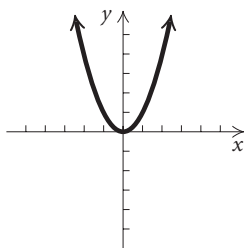

Square root function:
 $y = \sqrt{x}$

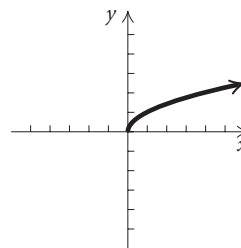

Cubing function:
 $y = x^3$

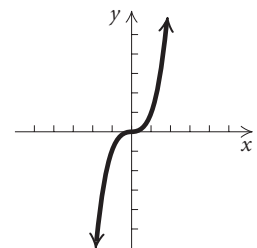

Cube root function:
 $y = \sqrt[3]{x}$

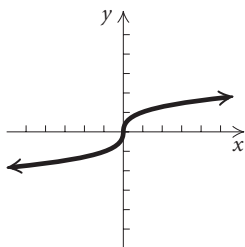

Reciprocal function:
 $y = \frac{1}{x}$

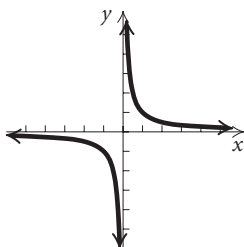

Absolute-value function:
 $y = |x|$

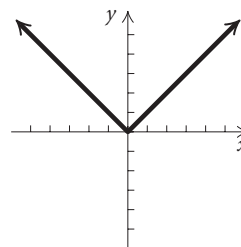

These functions can be considered building blocks for many other functions. We can create graphs of new functions by shifting them horizontally or vertically, stretching or shrinking them, and reflecting them across an axis. We now consider these **transformations**.

► Vertical Translations and Horizontal Translations

Suppose that we have a function given by $y = f(x)$. Let's explore the graphs of the new functions $y = f(x) + b$ and $y = f(x) - b$, for $b > 0$.

Consider the functions $y = \frac{1}{5}x^4$, $y = \frac{1}{5}x^4 + 5$, and $y = \frac{1}{5}x^4 - 3$ and compare their graphs. What pattern do you see? Test it with some other functions.

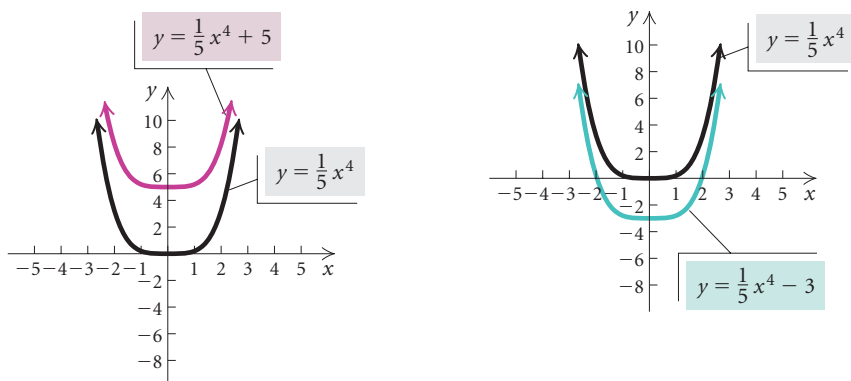

The effect of adding a constant to or subtracting a constant from $f(x)$ in $y = f(x)$ is a shift of the graph of $f(x)$ up or down. Such a shift is called a **vertical translation**.

Vertical Translation

For $b > 0$:

the graph of $y = f(x) + b$ is the graph of $y = f(x)$ shifted *up* b units;

the graph of $y = f(x) - b$ is the graph of $y = f(x)$ shifted *down* b units.

Suppose that we have a function given by $y = f(x)$. Let's explore the graphs of the new functions $y = f(x - d)$ and $y = f(x + d)$, for $d > 0$.

Consider the functions $y = \frac{1}{5}x^4$, $y = \frac{1}{5}(x - 3)^4$, and $y = \frac{1}{5}(x + 7)^4$ and compare their graphs. What pattern do you observe? Test it with some other functions.

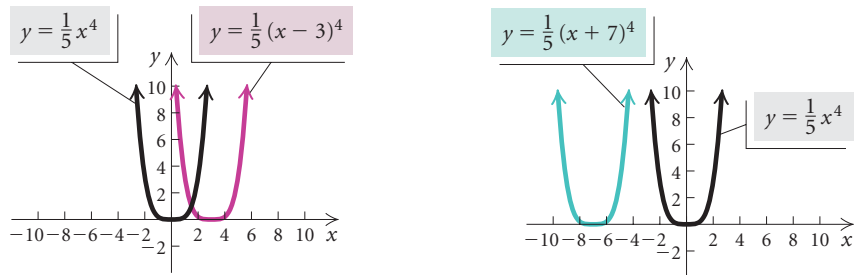

The effect of subtracting a constant from the x -value or adding a constant to the x -value in $y = f(x)$ is a shift of the graph of $f(x)$ to the right or left. Such a shift is called a **horizontal translation**.

Horizontal Translation

For $d > 0$:

the graph of $y = f(x - d)$ is the graph of $y = f(x)$ shifted *right* d units;

the graph of $y = f(x + d)$ is the graph of $y = f(x)$ shifted *left* d units.

EXAMPLE 4 Graph each of the following. Before doing so, describe how each graph can be obtained from one of the basic graphs shown on the preceding pages.

a) $g(x) = x^2 - 6$

b) $g(x) = |x - 4|$

c) $g(x) = \sqrt{x + 2}$

d) $h(x) = \sqrt{x + 2} - 3$

Solution

a) To graph $g(x) = x^2 - 6$, think of the graph of $f(x) = x^2$. Since $g(x) = f(x) - 6$, the graph of $g(x) = x^2 - 6$ is the graph of $f(x) = x^2$, shifted, or translated, *down* 6 units. (See Fig. 4.)

Let's compare some points on the graphs of f and g .

Points on f : $(-3, 9)$, $(0, 0)$, $(2, 4)$

Corresponding points on g : $(-3, 3)$, $(0, -6)$, $(2, -2)$

We note that the y -coordinate of a point on the graph of g is 6 less than the corresponding y -coordinate on the graph of f .

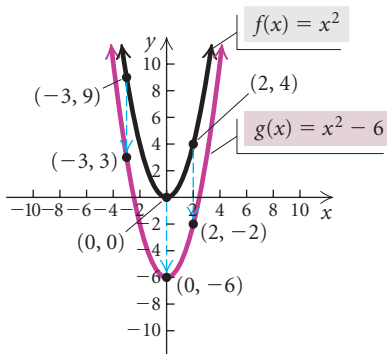

Figure 4

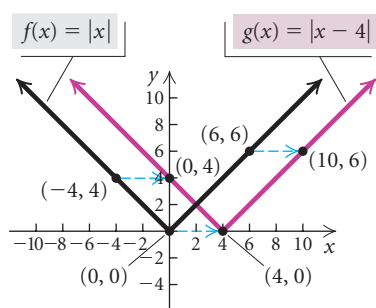

Figure 5

- b) To graph $g(x) = |x - 4|$, think of the graph of $f(x) = |x|$. Since $g(x) = f(x - 4)$, the graph of $g(x) = |x - 4|$ is the graph of $f(x) = |x|$ shifted *right* 4 units. (See Fig. 5.)

Let's again compare points on the two graphs.

Points on f Corresponding points on g

$$(-4, 4) \longrightarrow (0, 4)$$

$$(0, 0) \longrightarrow (4, 0)$$

$$(6, 6) \longrightarrow (10, 6)$$

Observing points on f and g , we see that the **x -coordinate** of a point on the graph of g is 4 more than the x -coordinate of the corresponding point on f .

- c) To graph $g(x) = \sqrt{x + 2}$, think of the graph of $f(x) = \sqrt{x}$. Since $g(x) = f(x + 2)$, the graph of $g(x) = \sqrt{x + 2}$ is the graph of $f(x) = \sqrt{x}$, shifted *left* 2 units. (See Fig. 6.)

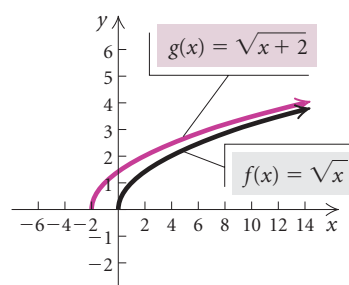

Figure 6

- d) To graph $h(x) = \sqrt{x + 2} - 3$, think of the graph of $f(x) = \sqrt{x}$. In part (c), we found that the graph of $g(x) = \sqrt{x + 2}$ is the graph of $f(x) = \sqrt{x}$ shifted *left* 2 units. Since $h(x) = g(x) - 3$, we shift the graph of $g(x) = \sqrt{x + 2}$ *down* 3 units. Together, the graph of $f(x) = \sqrt{x}$ is shifted *left* 2 units and *down* 3 units. (See Fig. 7.)

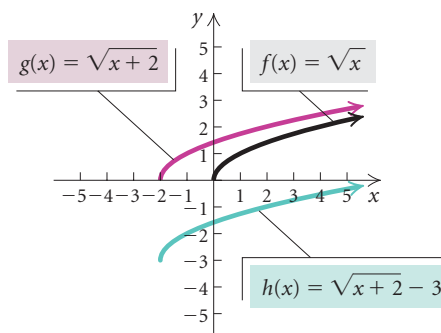

Figure 7

► Reflections

Suppose that we have a function given by $y = f(x)$. Let's explore the graphs of the new functions $y = -f(x)$ and $y = f(-x)$.

Compare the functions $y = f(x)$ and $y = -f(x)$ by observing the graphs of $y = \frac{1}{5}x^4$ and $y = -\frac{1}{5}x^4$ shown on the left below. What do you see? Test your observation with some other functions y_1 and y_2 where $y_2 = -y_1$.

Compare the functions $y = f(x)$ and $y = f(-x)$ by observing the graphs of $y = 2x^3 - x^4 + 5$ and $y = 2(-x)^3 - (-x)^4 + 5$ shown on the right below. What do you see? Test your observation with some other functions in which x is replaced with $-x$.

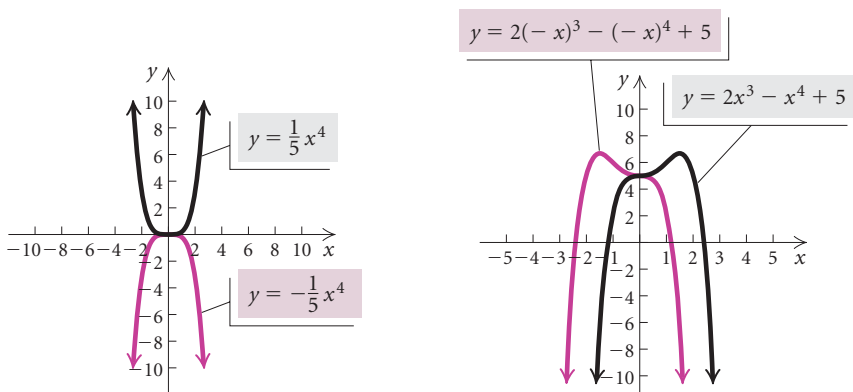

Given the graph of $y = f(x)$, we can reflect each point *across the x-axis* to obtain the graph of $y = -f(x)$. We can reflect each point of $y = f(x)$ *across the y-axis* to obtain the graph of $y = f(-x)$. The new graphs are called **reflections** of $y = f(x)$.

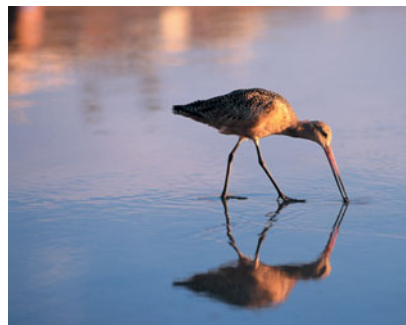
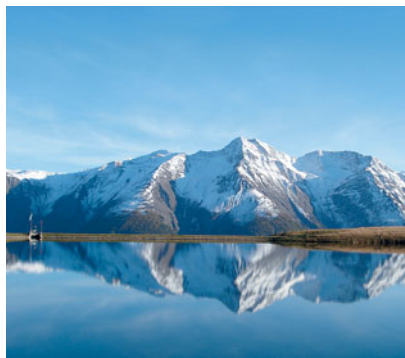

Reflections

The graph of $y = -f(x)$ is the **reflection** of the graph of $y = f(x)$ across the x -axis.

The graph of $y = f(-x)$ is the **reflection** of the graph of $y = f(x)$ across the y -axis.

If a point (x, y) is on the graph of $y = f(x)$, then $(x, -y)$ is on the graph of $y = -f(x)$, and $(-x, y)$ is on the graph of $y = f(-x)$.

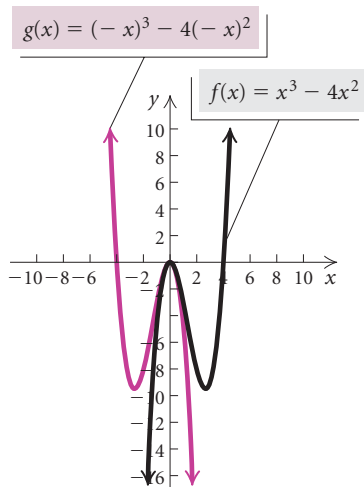

Figure 8

EXAMPLE 5 Graph each of the following. Before doing so, describe how each graph can be obtained from the graph of $f(x) = x^3 - 4x^2$.

a) $g(x) = (-x)^3 - 4(-x)^2$ b) $h(x) = 4x^2 - x^3$

Solution

a) We first note that

$$f(-x) = (-x)^3 - 4(-x)^2 = g(x).$$

Thus the graph of g is a *reflection* of the graph of f across the y -axis. (See Fig. 8.) If (x, y) is on the graph of f , then $(-x, y)$ is on the graph of g . For example, $(2, -8)$ is on f and $(-2, -8)$ is on g .

b) We first note that

$$\begin{aligned} -f(x) &= -(x^3 - 4x^2) \\ &= -x^3 + 4x^2 \\ &= 4x^2 - x^3 \\ &= h(x). \end{aligned}$$

Thus the graph of h is a reflection of the graph of f across the x -axis. (See Fig. 9.) If (x, y) is on the graph of f , then $(x, -y)$ is on the graph of h . For example, $(2, -8)$ is on f and $(2, 8)$ is on h .

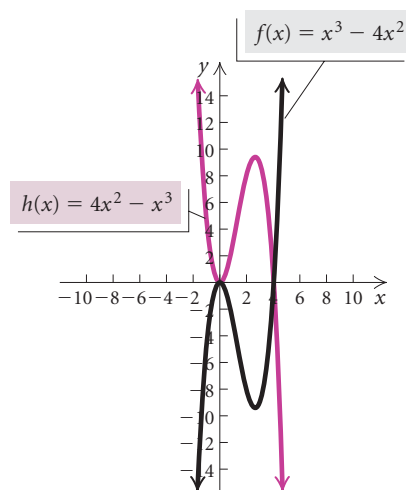

Figure 9



► Vertical and Horizontal Stretchings and Shrinkings

Suppose that we have a function given by $y = f(x)$. Let's explore the graphs of the new functions $y = af(x)$ and $y = f(cx)$.

Consider the functions $y = f(x) = x^3 - x$, $y = \frac{1}{10}(x^3 - x) = \frac{1}{10}f(x)$, $y = 2(x^3 - x) = 2f(x)$, and $y = -2(x^3 - x) = -2f(x)$ and compare their graphs. What pattern do you observe? Test it with some other functions.

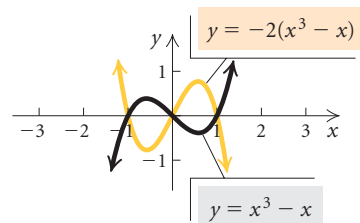
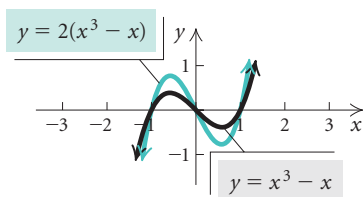
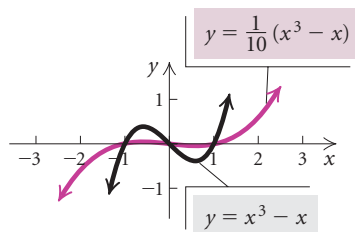

Consider any function f given by $y = f(x)$. Multiplying $f(x)$ by any constant a , where $|a| > 1$, to obtain $g(x) = af(x)$ will *stretch* the graph vertically away from the x -axis. If $0 < |a| < 1$, then the graph will be flattened or *shrunk* vertically toward the x -axis. If $a < 0$, the graph is also reflected across the x -axis.

Vertical Stretching and Shrinking

The graph of $y = af(x)$ can be obtained from the graph of $y = f(x)$ by

- stretching vertically for $|a| > 1$, or
- shrinking vertically for $0 < |a| < 1$.

For $a < 0$, the graph is also reflected across the x -axis.

(The y -coordinates of the graph of $y = af(x)$ can be obtained by multiplying the y -coordinates of $y = f(x)$ by a .)

Consider the functions $y = f(x) = x^3 - x$, $y = (2x)^3 - (2x) = f(2x)$, $y = (\frac{1}{2}x)^3 - (\frac{1}{2}x) = f(\frac{1}{2}x)$, and $y = (-\frac{1}{2}x)^3 - (-\frac{1}{2}x) = f(-\frac{1}{2}x)$ and compare their graphs. What pattern do you observe? Test it with some other functions.

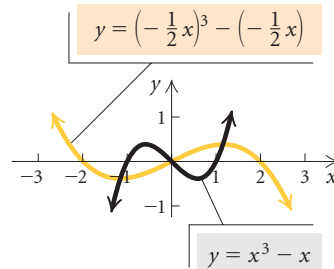
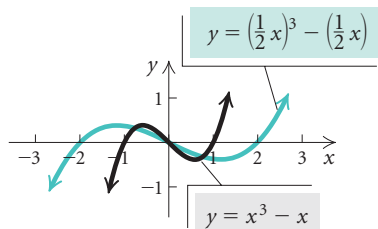
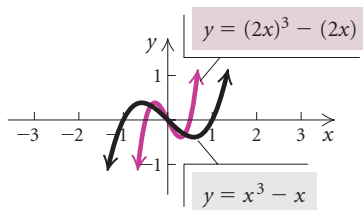

The constant c in the equation $g(x) = f(cx)$ will *shrink* the graph of $y = f(x)$ horizontally toward the y -axis if $|c| > 1$. If $0 < |c| < 1$, the graph will be *stretched* horizontally away from the y -axis. If $c < 0$, the graph is also reflected across the y -axis.

Horizontal Stretching and Shrinking

The graph of $y = f(cx)$ can be obtained from the graph of $y = f(x)$ by

shrinking horizontally for $|c| > 1$, or
stretching horizontally for $0 < |c| < 1$.

For $c < 0$, the graph is also reflected across the y -axis. (The x -coordinates of the graph of $y = f(cx)$ can be obtained by dividing the x -coordinates of the graph of $y = f(x)$ by c .)

It is instructive to use these concepts to create transformations of a given graph.

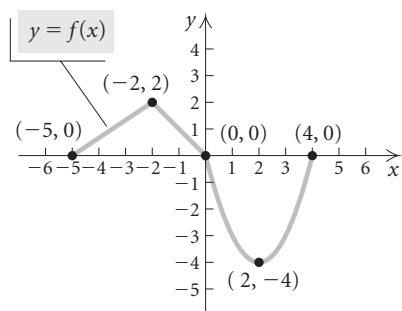

EXAMPLE 6 Shown at left is a graph of $y = f(x)$ for some function f . No formula for f is given. Graph each of the following.

- a) $g(x) = 2f(x)$
- b) $h(x) = \frac{1}{2}f(x)$
- c) $r(x) = f(2x)$
- d) $s(x) = f(\frac{1}{2}x)$
- e) $t(x) = f(-\frac{1}{2}x)$

Solution

a) Since $|2| > 1$, the graph of $g(x) = 2f(x)$ is a vertical stretching of the graph of $y = f(x)$ by a factor of 2. We can consider the key points $(-5, 0)$, $(-2, 2)$, $(0, 0)$, $(2, -4)$, and $(4, 0)$ on the graph of $y = f(x)$. The transformation multiplies each y -coordinate by 2 to obtain the key points $(-5, 0)$, $(-2, 4)$, $(0, 0)$, $(2, -8)$, and $(4, 0)$ on the graph of $g(x) = 2f(x)$. The graph is shown below.

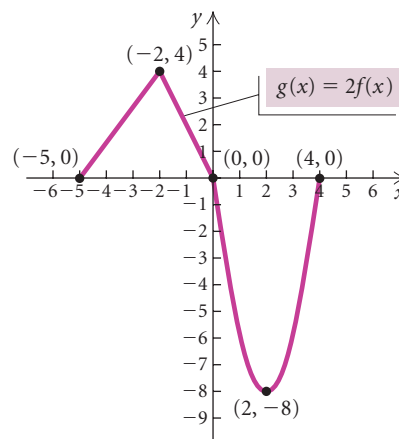

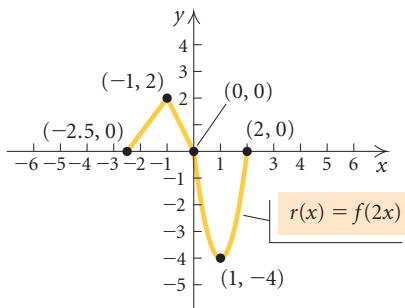
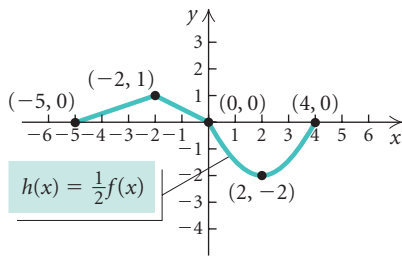

b) Since $|\frac{1}{2}| < 1$, the graph of $h(x) = \frac{1}{2}f(x)$ is a vertical shrinking of the graph of $y = f(x)$ by a factor of $\frac{1}{2}$. We again consider the key points $(-5, 0)$, $(-2, 2)$, $(0, 0)$, $(2, -4)$, and $(4, 0)$ on the graph of $y = f(x)$. The transformation multiplies each y -coordinate by $\frac{1}{2}$ to obtain the key points $(-5, 0)$, $(-2, 1)$, $(0, 0)$, $(2, -2)$, and $(4, 0)$ on the graph of $h(x) = \frac{1}{2}f(x)$. The graph is shown at left.

c) Since $|2| > 1$, the graph of $r(x) = f(2x)$ is a horizontal shrinking of the graph of $y = f(x)$. We consider the key points $(-5, 0)$, $(-2, 2)$, $(0, 0)$, $(2, -4)$, and $(4, 0)$ on the graph of $y = f(x)$. The transformation divides each x -coordinate by 2 to obtain the key points $(-2.5, 0)$, $(-1, 2)$, $(0, 0)$, $(1, -4)$, and $(2, 0)$ on the graph of $r(x) = f(2x)$. The graph is shown at left.

d) Since $|\frac{1}{2}| < 1$, the graph of $s(x) = f(\frac{1}{2}x)$ is a horizontal stretching of the graph of $y = f(x)$. We consider the key points $(-5, 0)$, $(-2, 2)$, $(0, 0)$, $(2, -4)$, and $(4, 0)$ on the graph of $y = f(x)$. The transformation divides each x -coordinate by $\frac{1}{2}$ (which is the same as multiplying by 2) to obtain the key points $(-10, 0)$, $(-4, 2)$, $(0, 0)$, $(4, -4)$, and $(8, 0)$ on the graph of $s(x) = f(\frac{1}{2}x)$. The graph is shown below.

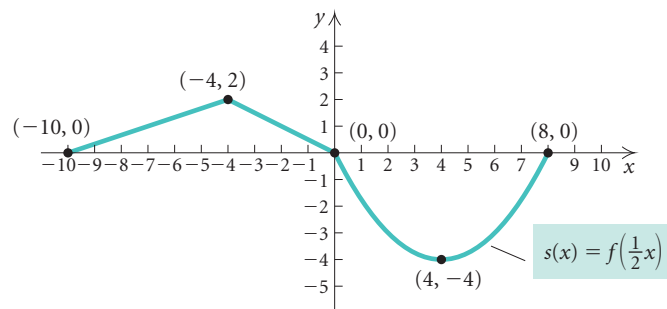

e) The graph of $t(x) = f(-\frac{1}{2}x)$ can be obtained by reflecting the graph in part (d) across the y -axis.

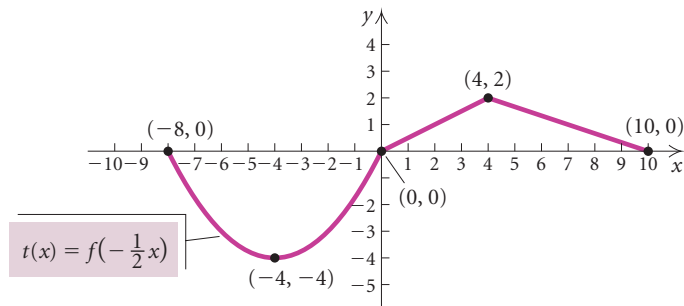

➔ Now Try Exercises 107 and 109.

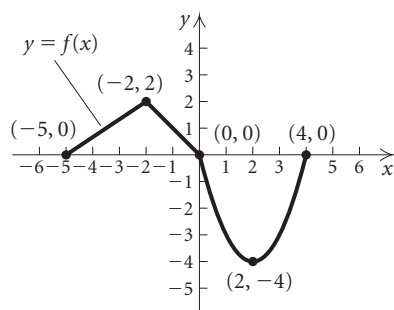

EXAMPLE 7 Use the graph of $y = f(x)$ shown at left to graph $y = -2f(x - 3) + 1$.

Shift 3 units
to the right

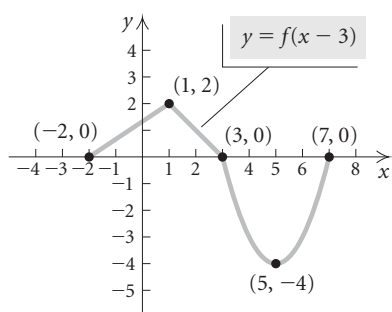

Stretch by a
factor of 2 vertically

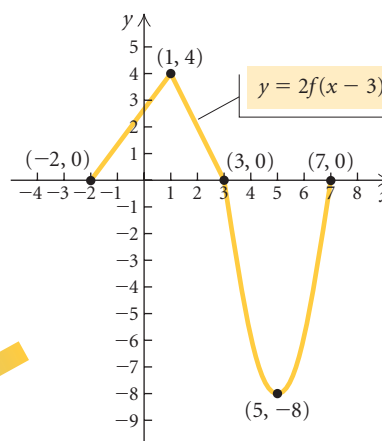

Reflect across x -axis

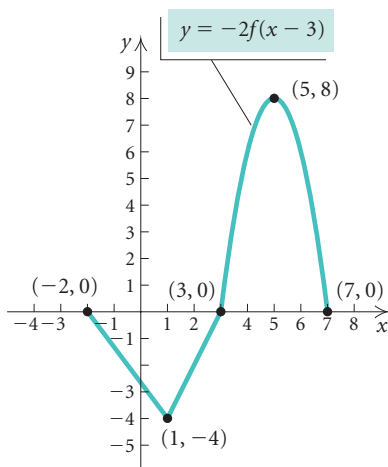

Shift up
1 unit

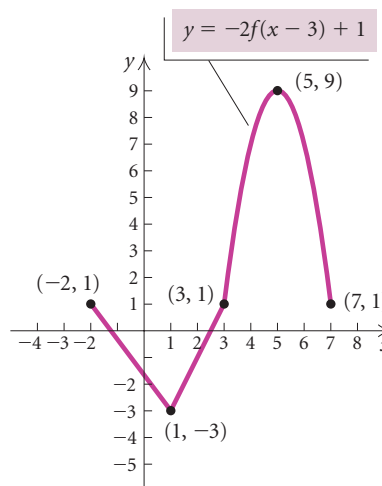

➔ Now Try Exercise 111.

Summary of Transformations of $y = f(x)$ **Vertical Translation: $y = f(x) \pm b$**

For $b > 0$:

the graph of $y = f(x) + b$ is the graph of $y = f(x)$ shifted *up* b units;

the graph of $y = f(x) - b$ is the graph of $y = f(x)$ shifted *down* b units.

Horizontal Translation: $y = f(x \mp d)$

For $d > 0$:

the graph of $y = f(x - d)$ is the graph of $y = f(x)$ shifted *right* d units;

the graph of $y = f(x + d)$ is the graph of $y = f(x)$ shifted *left* d units.

Reflections

Across the x-axis:

The graph of $y = -f(x)$ is the reflection of the graph of $y = f(x)$ across the x -axis.

Across the y-axis:

The graph of $y = f(-x)$ is the reflection of the graph of $y = f(x)$ across the y -axis.

Vertical Stretching or Shrinking: $y = af(x)$

The graph of $y = af(x)$ can be obtained from the graph of $y = f(x)$ by

stretching vertically for $|a| > 1$, or
shrinking vertically for $0 < |a| < 1$.

For $a < 0$, the graph is also reflected across the x -axis.

Horizontal Stretching or Shrinking: $y = f(cx)$

The graph of $y = f(cx)$ can be obtained from the graph of $y = f(x)$ by

shrinking horizontally for $|c| > 1$, or
stretching horizontally for $0 < |c| < 1$.

For $c < 0$, the graph is also reflected across the y -axis.

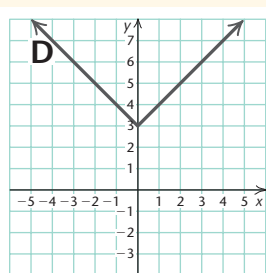
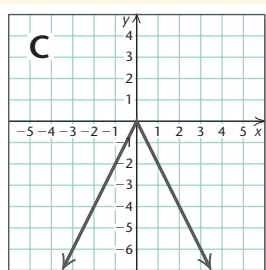
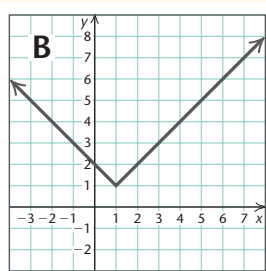
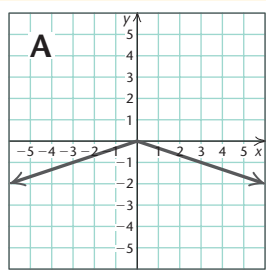
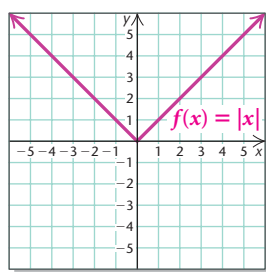

Visualizing the Graph

Match the function with its graph. Use transformation graphing techniques to obtain the graph of g from the basic function $f(x) = |x|$ shown at top left.

- $g(x) = -2|x|$
- $g(x) = |x - 1| + 1$
- $g(x) = -\left|\frac{1}{3}x\right|$
- $g(x) = |2x|$
- $g(x) = |x + 2|$
- $g(x) = |x| + 3$
- $g(x) = -\frac{1}{2}|x - 4|$
- $g(x) = \frac{1}{2}|x| - 3$
- $g(x) = -|x| - 2$

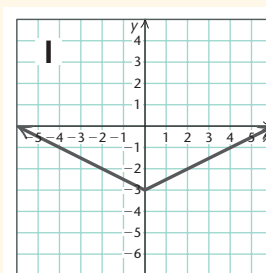
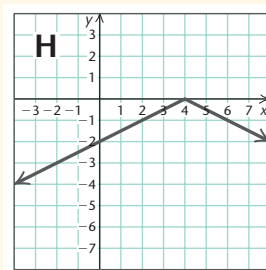
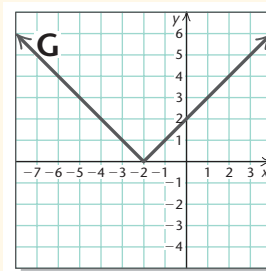
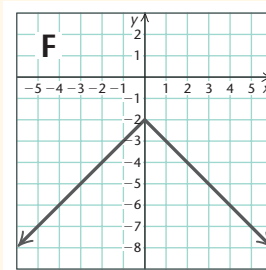
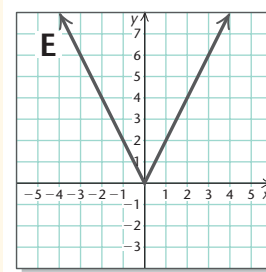

Answers on page A-12

2.4

Exercise Set

Determine visually whether the graph is symmetric with respect to the x -axis, the y -axis, and the origin.

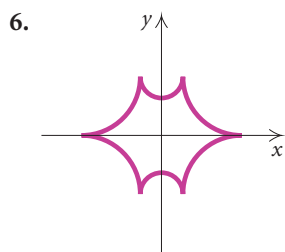
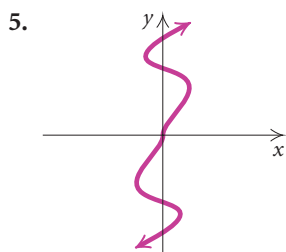
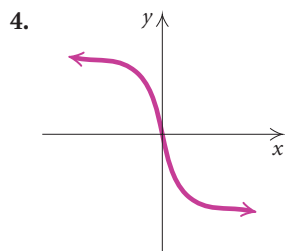
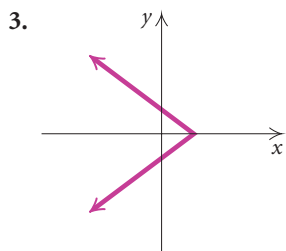
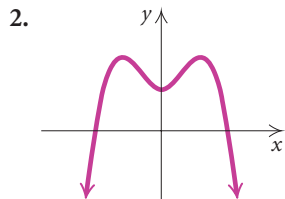
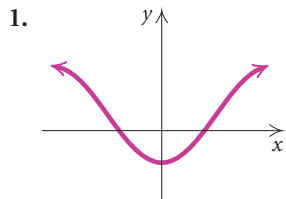

First, graph the equation and determine visually whether it is symmetric with respect to the x -axis, the y -axis, and the origin. Then verify your assertion algebraically.

7. $y = |x| - 2$

8. $y = |x + 5|$

9. $5y = 4x + 5$

10. $2x - 5 = 3y$

11. $5y = 2x^2 - 3$

12. $x^2 + 4 = 3y$

13. $y = \frac{1}{x}$

14. $y = -\frac{4}{x}$

Determine whether the graph is symmetric with respect to the x -axis, the y -axis, and the origin.

15. $5x - 5y = 0$

16. $6x + 7y = 0$

17. $3x^2 - 2y^2 = 3$

18. $5y = 7x^2 - 2x$

19. $y = |2x|$

20. $y^3 = 2x^2$

21. $2x^4 + 3 = y^2$

22. $2y^2 = 5x^2 + 12$

23. $3y^3 = 4x^3 + 2$

24. $3x = |y|$

25. $xy = 12$

26. $xy - x^2 = 3$

Find the point that is symmetric to the given point with respect to the x -axis, the y -axis, and the origin.

27. $(-5, 6)$

28. $(\frac{7}{2}, 0)$

29. $(-10, -7)$

30. $(1, \frac{3}{8})$

31. $(0, -4)$

32. $(8, -3)$

Determine visually whether the function is even, odd, or neither even nor odd.

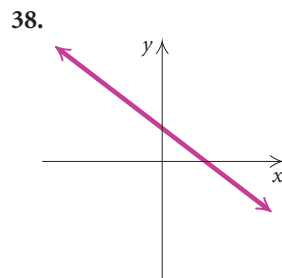
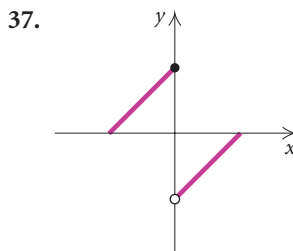
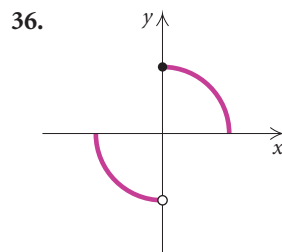
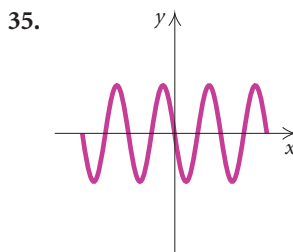
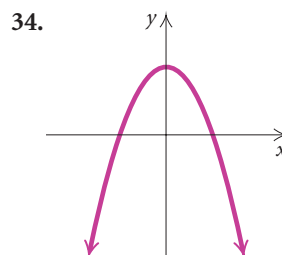
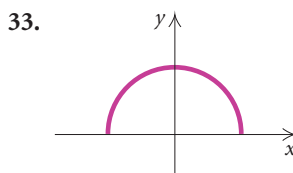

Determine whether the function is even, odd, or neither even nor odd.

39. $f(x) = -3x^3 + 2x$

40. $f(x) = 7x^3 + 4x - 2$

41. $f(x) = 5x^2 + 2x^4 - 1$

42. $f(x) = x + \frac{1}{x}$

43. $f(x) = x^{17}$

44. $f(x) = \sqrt[3]{x}$

45. $f(x) = x - |x|$

46. $f(x) = \frac{1}{x^2}$

47. $f(x) = 8$

48. $f(x) = \sqrt{x^2 + 1}$

Describe how the graph of the function can be obtained from one of the basic graphs on p. 194. Then graph the function.

49. $f(x) = (x - 3)^2$

50. $g(x) = x^2 + \frac{1}{2}$

51. $g(x) = x - 3$

52. $g(x) = -x - 2$

53. $h(x) = -\sqrt{x}$

54. $g(x) = \sqrt{x - 1}$

55. $h(x) = \frac{1}{x} + 4$

56. $g(x) = \frac{1}{x - 2}$

57. $h(x) = -3x + 3$

58. $f(x) = 2x + 1$

59. $h(x) = \frac{1}{2}|x| - 2$

60. $g(x) = -|x| + 2$

61. $g(x) = -(x - 2)^3$

62. $f(x) = (x + 1)^3$

63. $g(x) = (x + 1)^2 - 1$

64. $h(x) = -x^2 - 4$

65. $g(x) = \frac{1}{3}x^3 + 2$

66. $h(x) = (-x)^3$

67. $f(x) = \sqrt{x + 2}$

68. $f(x) = -\frac{1}{2}\sqrt{x - 1}$

69. $f(x) = \sqrt[3]{x} - 2$

70. $h(x) = \sqrt[3]{x + 1}$

Describe how the graph of the function can be obtained from one of the basic graphs on p. 194.

71. $g(x) = |3x|$

72. $f(x) = \frac{1}{2}\sqrt[3]{x}$

73. $h(x) = \frac{2}{x}$

74. $f(x) = |x - 3| - 4$

75. $f(x) = 3\sqrt{x} - 5$

76. $f(x) = 5 - \frac{1}{x}$

77. $g(x) = \frac{1}{3}|x| - 4$

78. $f(x) = \frac{2}{3}x^3 - 4$

79. $f(x) = -\frac{1}{4}(x - 5)^2$

80. $f(x) = (-x)^3 - 5$

81. $f(x) = \frac{1}{x + 3} + 2$

82. $g(x) = \sqrt{-x} + 5$

83. $h(x) = -(x - 3)^2 + 5$

84. $f(x) = 3(x + 4)^2 - 3$

The point $(-12, 4)$ is on the graph of $y = f(x)$. Find the corresponding point on the graph of $y = g(x)$.

85. $g(x) = \frac{1}{2}f(x)$

86. $g(x) = f(x - 2)$

87. $g(x) = f(-x)$

88. $g(x) = f(4x)$

89. $g(x) = f(x) - 2$

90. $g(x) = f\left(\frac{1}{2}x\right)$

91. $g(x) = 4f(x)$

92. $g(x) = -f(x)$

Given that $f(x) = x^2 + 3$, match the function g with a transformation of f from one of A–D.

93. $g(x) = x^2 + 4$ A. $f(x - 2)$

94. $g(x) = 9x^2 + 3$ B. $f(x) + 1$

95. $g(x) = (x - 2)^2 + 3$ C. $2f(x)$

96. $g(x) = 2x^2 + 6$ D. $f(3x)$

Write an equation for a function that has a graph with the given characteristics.

97. The shape of $y = x^2$, but upside-down and shifted right 8 units

98. The shape of $y = \sqrt{x}$, but shifted left 6 units and down 5 units

99. The shape of $y = |x|$, but shifted left 7 units and up 2 units

100. The shape of $y = x^3$, but upside-down and shifted right 5 units

101. The shape of $y = 1/x$, but shrunk horizontally by a factor of 2 and shifted down 3 units

102. The shape of $y = x^2$, but shifted right 6 units and up 2 units

103. The shape of $y = x^2$, but upside-down and shifted right 3 units and up 4 units

104. The shape of $y = |x|$, but stretched horizontally by a factor of 2 and shifted down 5 units

105. The shape of $y = \sqrt{x}$, but reflected across the y -axis and shifted left 2 units and down 1 unit

106. The shape of $y = 1/x$, but reflected across the x -axis and shifted up 1 unit

A graph of $y = f(x)$ follows. No formula for f is given. In Exercises 107–114, graph the given equation.

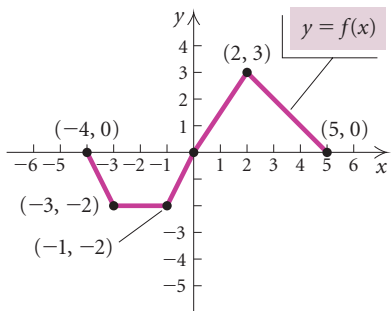

107. $g(x) = -2f(x)$

108. $g(x) = \frac{1}{2}f(x)$

109. $g(x) = f(-\frac{1}{2}x)$

110. $g(x) = f(2x)$

111. $g(x) = -\frac{1}{2}f(x - 1) + 3$

112. $g(x) = -3f(x + 1) - 4$

113. $g(x) = f(-x)$

114. $g(x) = -f(x)$

A graph of $y = g(x)$ follows. No formula for g is given. In Exercises 115–118, graph the given equation.

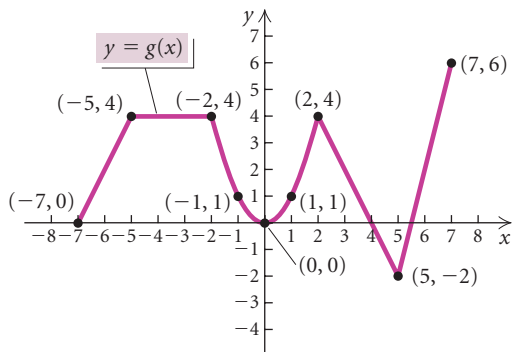

115. $h(x) = -g(x + 2) + 1$

116. $h(x) = \frac{1}{2}g(-x)$

117. $h(x) = g(2x)$

118. $h(x) = 2g(x - 1) - 3$

The graph of the function f is shown in figure (a). In Exercises 119–126, match the function g with one of the graphs (a)–(h), which follow. Some graphs may be used more than once and some may not be used at all.

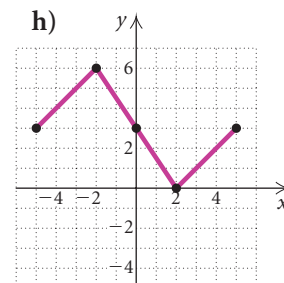
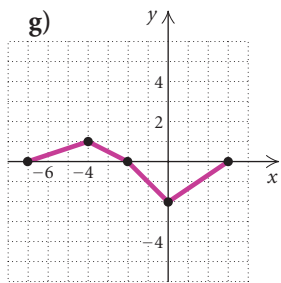
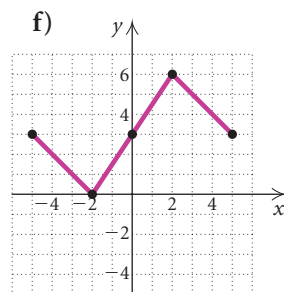
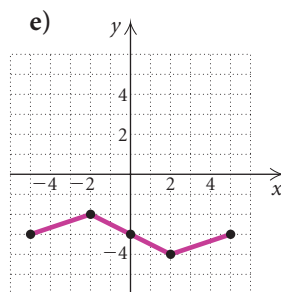
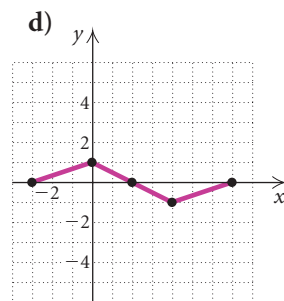
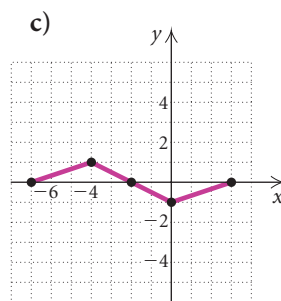
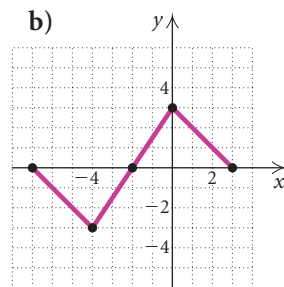
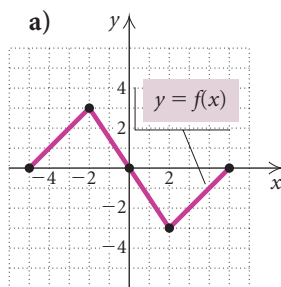

119. $g(x) = f(-x) + 3$

120. $g(x) = f(x) + 3$

121. $g(x) = -f(x) + 3$

122. $g(x) = -f(-x)$

123. $g(x) = \frac{1}{3}f(x - 2)$

124. $g(x) = \frac{1}{3}f(x) - 3$

125. $g(x) = \frac{1}{3}f(x + 2)$

126. $g(x) = -f(x + 2)$

For each pair of functions, determine if $g(x) = f(-x)$.

127. $f(x) = 2x^4 - 35x^3 + 3x - 5$,

$$g(x) = 2x^4 + 35x^3 - 3x - 5$$

128. $f(x) = \frac{1}{4}x^4 + \frac{1}{5}x^3 - 81x^2 - 17$,

$$g(x) = \frac{1}{4}x^4 + \frac{1}{5}x^3 + 81x^2 - 17$$

A graph of the function $f(x) = x^3 - 3x^2$ is shown below. Exercises 129–132 show graphs of functions transformed from this one. Find a formula for each function.

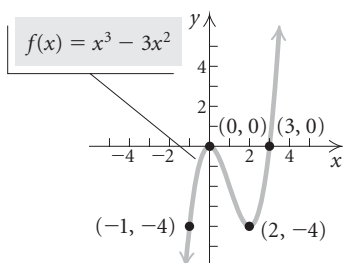

129.

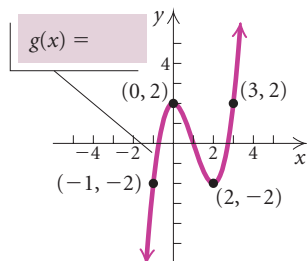

130.

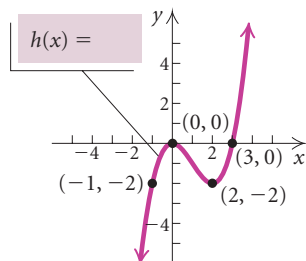

131.

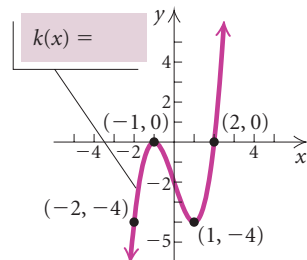

132.

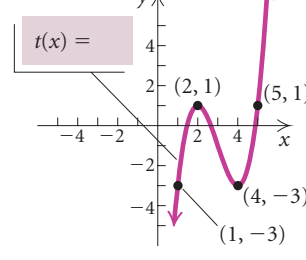

Skill Maintenance

133. **Olympics Ticket Prices.** Together, the price of a ticket for the opening ceremonies of the 2010 Winter Olympics in Vancouver, British Columbia, Canada, and a ticket to the closing ceremonies cost \$1875 (in Canadian dollars). The ticket for the opening ceremonies cost \$325 more than the ticket for the closing ceremonies. (Source: www.vancouver2010.com) Find the price of each ticket.



134. **Video Game Sales.** Sales of the video game Wii Fit totaled 3.5 million games in the first eleven months of 2009. This was 1 million less than three times the number of Madden NFL 10 games sold during the same period. (Source: The PPB Group) Find the number of Madden games sold.
135. **Gift Cards.** It is estimated that about \$5 billion in gift cards given as Christmas gifts in 2009 went unspent. This is about 6% of the total amount spent on gift cards. (Source: Tower Group) Find the total amount spent on gift cards.
136. **e-filing Taxes.** The number of tax returns filed electronically in 2009 (for tax year 2008) was 96.6 million. This was an increase of 8.1% over the number of returns e-filed in 2008 (for tax year 2007). (Source: Internal Revenue Service) Find the number of returns e-filed in 2008.

Synthesis

Use the graph of the function f shown below in Exercises 137 and 138.

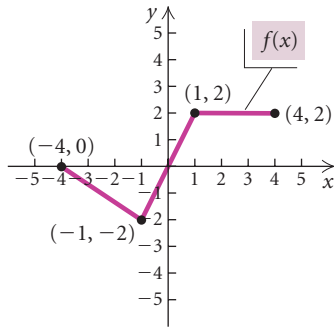

137. Graph: $y = |f(x)|$. 138. Graph: $y = f(|x|)$.

Use the graph of the function g shown below in Exercises 139 and 140.

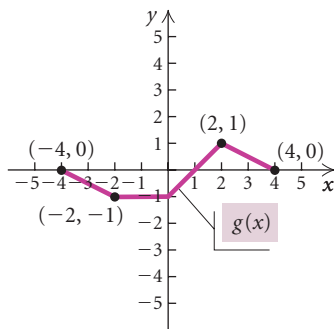

139. Graph: $y = g(|x|)$. 140. Graph: $y = |g(x)|$.

Determine whether the function is even, odd, or neither even nor odd.

141. $f(x) = x\sqrt{10 - x^2}$ 142. $f(x) = \frac{x^2 + 1}{x^3 - 1}$

Determine whether the graph is symmetric with respect to the x -axis, the y -axis, and the origin.

143. $x^3 = y^2(2 - x)$

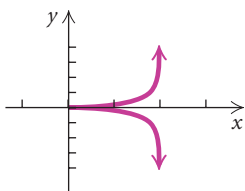

144. $(x^2 + y^2)^2 = 2xy$

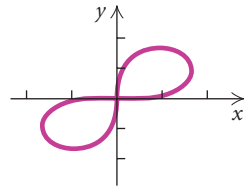

145. $y^2 + 4xy^2 - y^4 = x^4 - 4x^3 + 3x^2 + 2x^2y^2$

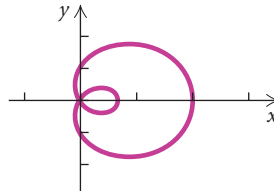

146. The graph of $f(x) = |x|$ passes through the points $(-3, 3)$, $(0, 0)$, and $(3, 3)$. Transform this function to one whose graph passes through the points $(5, 1)$, $(8, 4)$, and $(11, 1)$.

147. If $(-1, 5)$ is a point on the graph of $y = f(x)$, find b such that $(2, b)$ is on the graph of $y = f(x - 3)$.

State whether each of the following is true or false.

148. The product of two odd functions is odd.
149. The sum of two even functions is even.
150. The product of an even function and an odd function is odd.
151. Show that if f is any function, then the function E defined by

$$E(x) = \frac{f(x) + f(-x)}{2}$$

is even.

152. Show that if f is any function, then the function O defined by

$$O(x) = \frac{f(x) - f(-x)}{2}$$

is odd.

153. Consider the functions E and O of Exercises 151 and 152.

- a) Show that $f(x) = E(x) + O(x)$. This means that every function can be expressed as the sum of an even function and an odd function.
b) Let $f(x) = 4x^3 - 11x^2 + \sqrt{x} - 10$. Express f as a sum of an even function and an odd function.

Variation and Applications

2.5

- ▶ Find equations of direct variation, inverse variation, and combined variation given values of the variables.
- ▶ Solve applied problems involving variation.

We now extend our study of formulas and functions by considering applications involving variation.

▶ Direct Variation

Suppose a veterinary assistant earns \$10 per hour. In 1 hr, \$10 is earned; in 2 hr, \$20 is earned; in 3 hr, \$30 is earned; and so on. This gives rise to a set of ordered pairs:

$$(1, 10), \quad (2, 20), \quad (3, 30), \quad (4, 40), \quad \text{and so on.}$$

Note that the ratio of the second coordinate to the first coordinate is the same number for each pair:

$$\frac{10}{1} = 10, \quad \frac{20}{2} = 10, \quad \frac{30}{3} = 10, \quad \frac{40}{4} = 10, \quad \text{and so on.}$$

Whenever a situation produces pairs of numbers in which the *ratio is constant*, we say that there is **direct variation**. Here the amount earned E varies directly as the time worked t :

$$\frac{E}{t} = 10 \text{ (a constant), or } E = 10t,$$

or, using function notation, $E(t) = 10t$. This equation is an equation of **direct variation**. The coefficient, 10, is called the **variation constant**. In this case, it is the rate of change of earnings with respect to time.

Direct Variation

If a situation gives rise to a linear function $f(x) = kx$, or $y = kx$, where k is a positive constant, we say that we have **direct variation**, or that **y varies directly as x** , or that **y is directly proportional to x** . The number k is called the **variation constant**, or the **constant of proportionality**.

Veterinary Assistant's Earnings

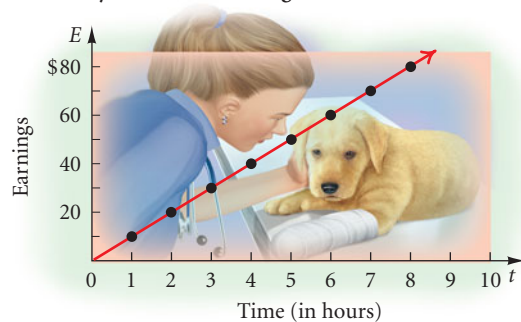

The graph of $y = kx$, $k > 0$, always goes through the origin and rises from left to right. Note that as x increases, y increases. That is, the function is increasing on the interval $(0, \infty)$. The constant k is also the slope of the line.

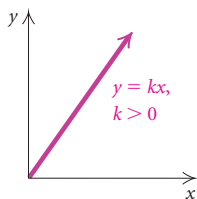

EXAMPLE 1 Find the variation constant and an equation of variation in which y varies directly as x , and $y = 32$ when $x = 2$.

Solution We know that $(2, 32)$ is a solution of $y = kx$. Thus,

$$y = kx$$

$$32 = k \cdot 2 \quad \text{Substituting}$$

$$\frac{32}{2} = k \quad \text{Solving for } k$$

$$16 = k. \quad \text{Simplifying}$$

The variation constant, 16, is the rate of change of y with respect to x . The equation of variation is $y = 16x$.

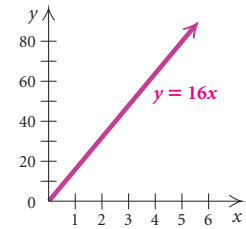

➔ Now Try Exercise 1.

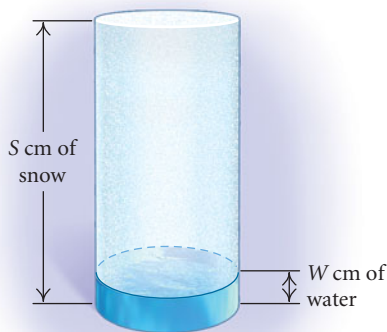

EXAMPLE 2 *Water from Melting Snow.* The number of centimeters W of water produced from melting snow varies directly as S , the number of centimeters of snow. Meteorologists have found that under certain conditions 150 cm of snow will melt to 16.8 cm of water. To how many centimeters of water will 200 cm of snow melt under the same conditions?

Solution We can express the amount of water as a function of the amount of snow. Thus, $W(S) = kS$, where k is the variation constant. We first find k using the given data and then find an equation of variation:

$$W(S) = kS \quad \text{W varies directly as S.}$$

$$W(150) = k \cdot 150 \quad \text{Substituting 150 for S}$$

$$16.8 = k \cdot 150 \quad \text{Replacing } W(150) \text{ with } 16.8$$

$$\frac{16.8}{150} = k \quad \text{Solving for } k$$

$$0.112 = k. \quad \text{This is the variation constant.}$$

The equation of variation is $W(S) = 0.112S$.

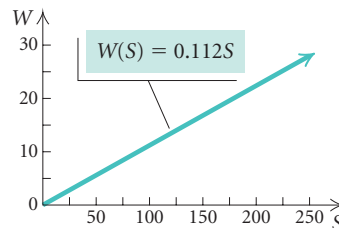

Next, we use the equation to find how many centimeters of water will result from melting 200 cm of snow:

$$W(S) = 0.112S$$

$$W(200) = 0.112(200) \quad \text{Substituting}$$

$$= 22.4.$$

Thus, 200 cm of snow will melt to 22.4 cm of water.

➔ Now Try Exercise 17.



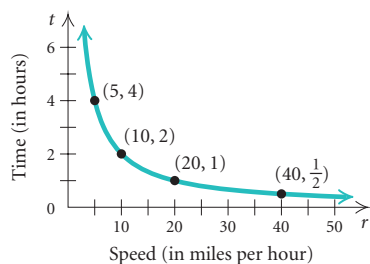

► Inverse Variation

Suppose a bus is traveling a distance of 20 mi. At a speed of 5 mph, the trip will take 4 hr; at 10 mph, it will take 2 hr; at 20 mph, it will take 1 hr; at 40 mph, it will take $\frac{1}{2}$ hr; and so on. We plot this information on a graph, using speed as the first coordinate and time as the second coordinate to determine a set of ordered pairs:

$$(5, 4), \quad (10, 2), \quad (20, 1), \quad \left(40, \frac{1}{2}\right), \quad \text{and so on.}$$

Note that the products of the coordinates are all the same number:

$$5 \cdot 4 = 20, \quad 10 \cdot 2 = 20, \quad 20 \cdot 1 = 20, \quad 40 \cdot \frac{1}{2} = 20, \quad \text{and so on.}$$

Whenever a situation produces pairs of numbers in which the *product is constant*, we say that there is **inverse variation**. Here the time varies inversely as the speed, or rate:

$$rt = 20 \text{ (a constant)}, \quad \text{or} \quad t = \frac{20}{r},$$

or, using function notation, $t(r) = 20/r$. This equation is an equation of **inverse variation**. The coefficient, 20, is called the **variation constant**. Note that as the first number increases, the second number decreases.

The graph of $y = k/x$, $k > 0$, is like the one shown below. Note that as x increases, y decreases. That is, the function is decreasing on the interval $(0, \infty)$.

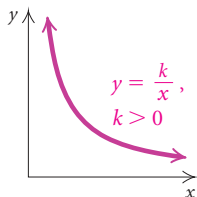

Inverse Variation

If a situation gives rise to a function $f(x) = k/x$, or $y = k/x$, where k is a positive constant, we say that we have **inverse variation**, or that **y varies inversely as x** , or that **y is inversely proportional to x** . The number k is called the **variation constant**, or the **constant of proportionality**.

EXAMPLE 3 Find the variation constant and an equation of variation in which y varies inversely as x , and $y = 16$ when $x = 0.3$.

Solution We know that $(0.3, 16)$ is a solution of $y = k/x$. We substitute:

$$y = \frac{k}{x}$$

$$16 = \frac{k}{0.3}$$

$$(0.3)16 = k$$

$$4.8 = k.$$

Substituting

Solving for k

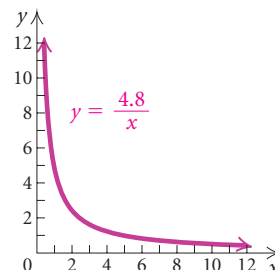

The variation constant is 4.8. The equation of variation is $y = 4.8/x$.

➔ Now Try Exercise 3.

There are many problems that translate to an equation of inverse variation.



EXAMPLE 4 *Filling a Swimming Pool.* The time t required to fill a swimming pool varies inversely as the rate of flow r of water into the pool. A tank truck can fill a pool in 90 min at a rate of 1500 L/min. How long would it take to fill the pool at a rate of 1800 L/min?

Solution We can express the amount of time required as a function of the rate of flow. Thus we have $t(r) = k/r$. We first find k using the given information and then find an equation of variation:

$$t(r) = \frac{k}{r} \quad \text{\textit{t varies inversely as r.}}$$

$$t(1500) = \frac{k}{1500} \quad \text{\textit{Substituting 1500 for r}}$$

$$90 = \frac{k}{1500} \quad \text{\textit{Replacing } t(1500) \text{ with 90}}$$

$$90 \cdot 1500 = k \quad \text{\textit{Solving for k}}$$

$$135,000 = k. \quad \text{\textit{This is the variation constant.}}$$

The equation of variation is

$$t(r) = \frac{135,000}{r}.$$

Next, we use the equation to find the time that it would take to fill the pool at a rate of 1800 L/min:

$$t(r) = \frac{135,000}{r}$$

$$t(1800) = \frac{135,000}{1800} \quad \text{\textit{Substituting}}$$

$$t = 75.$$

Thus it would take 75 min to fill the pool at a rate of 1800 L/min.

 **Now Try Exercise 15.**

Let's summarize the procedure for solving variation problems.

Solving Variation Problems

1. Determine whether direct variation or inverse variation applies.
2. Write an equation of the form $y = kx$ (for direct variation) or $y = k/x$ (for inverse variation), substitute the known values, and solve for k .
3. Write the equation of variation, and use it to find the unknown value(s) in the problem.

► Combined Variation

We now look at other kinds of variation.

y varies **directly as the n th power of x** if there is some positive constant k such that

$$y = kx^n.$$

y varies **inversely as the n th power of x** if there is some positive constant k such that

$$y = \frac{k}{x^n}.$$

y varies **jointly as x and z** if there is some positive constant k such that

$$y = kxz.$$

There are other types of combined variation as well. Consider the formula for the volume of a right circular cylinder, $V = \pi r^2 h$, in which V , r , and h are variables and π is a constant. We say that V varies jointly as h and the square of r . In this formula, π is the variation constant.

EXAMPLE 5 Find an equation of variation in which y varies directly as the square of x , and $y = 12$ when $x = 2$.

Solution We write an equation of variation and find k :

$$y = kx^2$$

$$12 = k \cdot 2^2 \quad \text{Substituting}$$

$$12 = k \cdot 4$$

$$3 = k.$$

Thus, $y = 3x^2$.

➔ **Now Try Exercise 27.**

EXAMPLE 6 Find an equation of variation in which y varies jointly as x and z , and $y = 42$ when $x = 2$ and $z = 3$.

Solution We have

$$y = kxz$$

$$42 = k \cdot 2 \cdot 3 \quad \text{Substituting}$$

$$42 = k \cdot 6$$

$$7 = k.$$

Thus, $y = 7xz$.

➔ **Now Try Exercise 29.**

EXAMPLE 7 Find an equation of variation in which y varies jointly as x and z and inversely as the square of w , and $y = 105$ when $x = 3$, $z = 20$, and $w = 2$.

Solution We have

$$y = k \cdot \frac{xz}{w^2}$$

$$105 = k \cdot \frac{3 \cdot 20}{2^2} \quad \text{Substituting}$$

$$105 = k \cdot 15$$

$$7 = k.$$

$$\text{Thus, } y = 7 \frac{xz}{w^2}, \text{ or } y = \frac{7xz}{w^2}.$$

➔ Now Try Exercise 33.

Many applied problems can be modeled using equations of combined variation.



EXAMPLE 8 *Volume of a Tree.* The volume of wood V in a tree varies jointly as the height h and the square of the girth g . (Girth is distance around.) If the volume of a redwood tree is 216 m^3 when the height is 30 m and the girth is 1.5 m, what is the height of a tree whose volume is 960 m^3 and whose girth is 2 m?

Solution We first find k using the first set of data. Then we solve for h using the second set of data.

$$V = khg^2$$

$$216 = k \cdot 30 \cdot 1.5^2$$

$$216 = k \cdot 30 \cdot 2.25$$

$$216 = k \cdot 67.5$$

$$3.2 = k$$

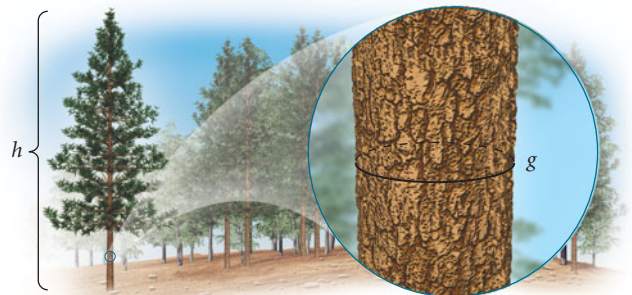

Thus the equation of variation is $V = 3.2hg^2$. We substitute the second set of data into the equation:

$$960 = 3.2 \cdot h \cdot 2^2$$

$$960 = 3.2 \cdot h \cdot 4$$

$$960 = 12.8 \cdot h$$

$$75 = h.$$

The height of the tree is 75 m.

➔ Now Try Exercise 35.

2.5

Exercise Set

Find the variation constant and an equation of variation for the given situation.

- y varies directly as x , and $y = 54$ when $x = 12$
- y varies directly as x , and $y = 0.1$ when $x = 0.2$
- y varies inversely as x , and $y = 3$ when $x = 12$
- y varies inversely as x , and $y = 12$ when $x = 5$
- y varies directly as x , and $y = 1$ when $x = \frac{1}{4}$
- y varies inversely as x , and $y = 0.1$ when $x = 0.5$
- y varies inversely as x , and $y = 32$ when $x = \frac{1}{8}$
- y varies directly as x , and $y = 3$ when $x = 33$
- y varies directly as x , and $y = \frac{3}{4}$ when $x = 2$
- y varies inversely as x , and $y = \frac{1}{5}$ when $x = 35$
- y varies inversely as x , and $y = 1.8$ when $x = 0.3$
- y varies directly as x , and $y = 0.9$ when $x = 0.4$
- Sales Tax.** The amount of sales tax paid on a product is directly proportional to its purchase price. In Indiana, the sales tax on a Sony Reader that sells for \$260 is \$17.50. What is the sales tax on an e-book that sells for \$21?
- Child's Allowance.** The Gemmers decide to give their children a weekly allowance that is directly proportional to each child's age. Their 6-year-old daughter receives an allowance of \$4.50. What is their 11-year-old son's allowance?
- Beam Weight.** The weight W that a horizontal beam can support varies inversely as the length L of the beam. Suppose an 8-m beam can support 1200 kg. How many kilograms can a 14-m beam support?
- Rate of Travel.** The time t required to drive a fixed distance varies inversely as the speed r . It takes 5 hr at a speed of 80 km/h to drive a fixed distance. How long will it take to drive the same distance at a speed of 70 km/h?
- Fat Intake.** The maximum number of grams of fat that should be in a diet varies directly as a person's weight. A person weighing 120 lb should have no more than 60 g of fat per day. What is the maximum daily fat intake for a person weighing 180 lb?
- House of Representatives.** The number of representatives N that each state has varies directly as the number of people P living in the state. If New York, with 19,254,630 residents, has 29 representatives, how many representatives does Colorado, with a population of 4,665,177, have?

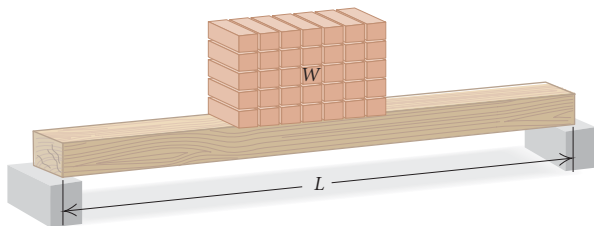

- Work Rate.** The time T required to do a job varies inversely as the number of people P working. It takes 5 hr for 7 bricklayers to build a park wall. How long will it take 10 bricklayers to complete the job?
- Pumping Rate.** The time t required to empty a tank varies inversely as the rate r of pumping. If a pump can empty a tank in 45 min at the rate of 600 kL/min, how long will it take the pump to empty the same tank at the rate of 1000 kL/min?

21. **Hooke's Law.** Hooke's law states that the distance d that a spring will stretch varies directly as the mass m of an object hanging from the spring. If a 3-kg mass stretches a spring 40 cm, how far will a 5-kg mass stretch the spring?

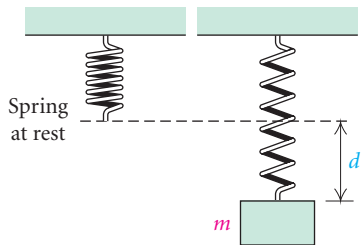

22. **Relative Aperture.** The relative aperture, or f-stop, of a 23.5-mm diameter lens is directly proportional to the focal length F of the lens. If a 150-mm focal length has an f-stop of 6.3, find the f-stop of a 23.5-mm diameter lens with a focal length of 80 mm.
23. **Musical Pitch.** The pitch P of a musical tone varies inversely as its wavelength W . One tone has a pitch of 330 vibrations per second and a wavelength of 3.2 ft. Find the wavelength of another tone that has a pitch of 550 vibrations per second.



24. **Weight on Mars.** The weight M of an object on Mars varies directly as its weight E on Earth. A person who weighs 95 lb on Earth weighs 38 lb on Mars. How much would a 100-lb person weigh on Mars?

Find an equation of variation for the given situation.

25. y varies inversely as the square of x , and $y = 0.15$ when $x = 0.1$
26. y varies inversely as the square of x , and $y = 6$ when $x = 3$
27. y varies directly as the square of x , and $y = 0.15$ when $x = 0.1$
28. y varies directly as the square of x , and $y = 6$ when $x = 3$
29. y varies jointly as x and z , and $y = 56$ when $x = 7$ and $z = 8$
30. y varies directly as x and inversely as z , and $y = 4$ when $x = 12$ and $z = 15$
31. y varies jointly as x and the square of z , and $y = 105$ when $x = 14$ and $z = 5$
32. y varies jointly as x and z and inversely as w , and $y = \frac{3}{2}$ when $x = 2$, $z = 3$, and $w = 4$
33. y varies jointly as x and z and inversely as the product of w and p , and $y = \frac{3}{28}$ when $x = 3$, $z = 10$, $w = 7$, and $p = 8$
34. y varies jointly as x and z and inversely as the square of w , and $y = \frac{12}{5}$ when $x = 16$, $z = 3$, and $w = 5$
35. **Intensity of Light.** The intensity I of light from a light bulb varies inversely as the square of the distance d from the bulb. Suppose that I is 90 W/m^2 (watts per square meter) when the distance is 5 m. How much *farther* would it be to a point where the intensity is 40 W/m^2 ?
36. **Atmospheric Drag.** Wind resistance, or atmospheric drag, tends to slow down moving objects. Atmospheric drag varies jointly as an object's surface area A and velocity v . If a car traveling at a speed of 40 mph with a surface area of 37.8 ft^2 experiences a drag of 222 N (Newtons), how fast must a car with 51 ft^2 of surface area travel in order to experience a drag force of 430 N?

37. **Stopping Distance of a Car.** The stopping distance d of a car after the brakes have been applied varies directly as the square of the speed r . If a car traveling 60 mph can stop in 200 ft, how fast can a car travel and still stop in 72 ft?

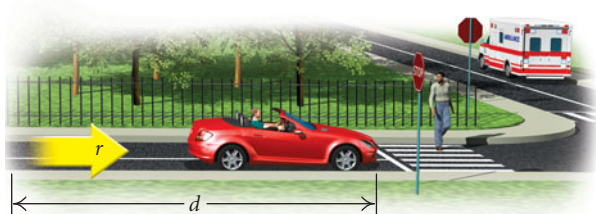

38. **Weight of an Astronaut.** The weight W of an object varies inversely as the square of the distance d from the center of the earth. At sea level (3978 mi from the center of the earth), an astronaut weighs 220 lb. Find his weight when he is 200 mi above the surface of the earth.
39. **Earned-Run Average.** A pitcher's earned-run average E varies directly as the number R of earned runs allowed and inversely as the number I of innings pitched. In 2009, Zack Greinke of the Kansas City Royals had an earned-run average of 2.16. He gave up 55 earned runs in 229.1 innings. How many earned runs would he have given up had he pitched 245 innings with the same average? Round to the nearest whole number.
40. **Boyle's Law.** The volume V of a given mass of a gas varies directly as the temperature T and inversely as the pressure P . If $V = 231 \text{ cm}^3$ when $T = 42^\circ$ and $P = 20 \text{ kg/cm}^2$, what is the volume when $T = 30^\circ$ and $P = 15 \text{ kg/cm}^2$?

Skill Maintenance

In each of Exercises 41–45, fill in the blank with the correct term. Some of the given choices will not be used.

even function	relative maximum
odd function	relative minimum
constant function	solution
composite function	zero
direct variation	perpendicular
inverse variation	parallel

41. Nonvertical lines are _____ if and only if they have the same slope and different y -intercepts.
42. An input c of a function f is a _____ of the function if $f(c) = 0$.
43. For a function f for which $f(c)$ exists, $f(c)$ is a _____ if $f(c)$ is the lowest point in some open interval.
44. If the graph of a function is symmetric with respect to the origin, then f is an _____.
45. An equation $y = k/x$ is an equation of _____.

Synthesis

46. In each of the following equations, state whether y varies directly as x , inversely as x , or neither directly nor inversely as x .
- $7xy = 14$
 - $x - 2y = 12$
 - $-2x + 3y = 0$
 - $x = \frac{3}{4}y$
 - $\frac{x}{y} = 2$
47. **Volume and Cost.** An 18-oz jar of peanut butter in the shape of a right circular cylinder is 5 in. high and 3 in. in diameter and sells for \$1.80. In the same store, a 28-oz jar of the same brand is $5\frac{1}{2}$ in. high and $3\frac{1}{4}$ in. in diameter. If the cost is directly proportional to volume, what should the price of the larger jar be? If the cost is directly proportional to weight, what should the price of the larger jar be?
48. Describe in words the variation given by the equation
- $$Q = \frac{kp^2}{q^3}.$$
49. **Area of a Circle.** The area of a circle varies directly as the square of the length of a diameter. What is the variation constant?

Chapter 2 Summary and Review

STUDY GUIDE

KEY TERMS AND CONCEPTS

Increasing, Decreasing, and Constant Functions

A function f is said to be **increasing** on an *open* interval I , if for all a and b in that interval, $a < b$ implies $f(a) < f(b)$.

A function f is said to be **decreasing** on an *open* interval I , if for all a and b in that interval, $a < b$ implies $f(a) > f(b)$.

A function f is said to be **constant** on an *open* interval I , if for all a and b in that interval, $f(a) = f(b)$.

Relative Maxima and Minima

Suppose that f is a function for which $f(c)$ exists for some c in the domain of f . Then:

$f(c)$ is a **relative maximum** if there exists an *open* interval I containing c such that $f(c) > f(x)$ for all x in I , where $x \neq c$; and

$f(c)$ is a **relative minimum** if there exists an *open* interval I containing c such that $f(c) < f(x)$ for all x in I , where $x \neq c$.

Some applied problems can be modeled by functions.

EXAMPLES

SECTION 2.1: INCREASING, DECREASING, AND PIECEWISE FUNCTIONS; APPLICATIONS

Determine the intervals on which the function is (a) increasing; (b) decreasing; (c) constant.

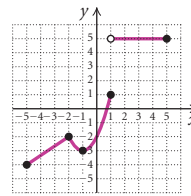

- As x -values increase from -5 to -2 , y -values increase from -4 to -2 ; y -values also increase as x -values increase from -1 to 1 . Thus the function is increasing on the intervals $(-5, -2)$ and $(-1, 1)$.
- As x -values increase from -2 to -1 , y -values decrease from -2 to -3 , so the function is decreasing on the interval $(-2, -1)$.
- As x -values increase from 1 to 5 , y remains 5 , so the function is constant on the interval $(1, 5)$.

Determine any relative maxima or minima of the function.

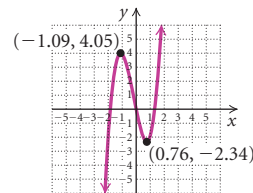

We see from the graph that the function has one relative maximum, 4.05 . It occurs when $x = -1.09$. We also see that there is one relative minimum, -2.34 . It occurs when $x = 0.76$.

See Examples 3 and 4 on pages 161 and 162.

SECTION 2.4: SYMMETRY AND TRANSFORMATIONS

Algebraic Tests of Symmetry

x-axis: If replacing y with $-y$ produces an equivalent equation, then the graph is *symmetric with respect to the x-axis*.

y-axis: If replacing x with $-x$ produces an equivalent equation, then the graph is *symmetric with respect to the y-axis*.

Origin: If replacing x with $-x$ and y with $-y$ produces an equivalent equation, then the graph is *symmetric with respect to the origin*.

Even Functions and Odd Functions

If the graph of a function is symmetric with respect to the y -axis, we say that it is an **even function**. That is, for each x in the domain of f , $f(x) = f(-x)$.

If the graph of a function is symmetric with respect to the origin, we say that it is an **odd function**. That is, for each x in the domain of f , $f(-x) = -f(x)$.

Test $y = 2x^3$ for symmetry with respect to the x -axis, the y -axis, and the origin.

x-axis: We replace y with $-y$:

$$\begin{aligned} -y &= 2x^3 \\ y &= -2x^3. \quad \text{Multiplying by } -1 \end{aligned}$$

The resulting equation is *not* equivalent to the original equation, so the graph is *not* symmetric with respect to the x -axis.

y-axis: We replace x with $-x$:

$$\begin{aligned} y &= 2(-x)^3 \\ y &= -2x^3. \end{aligned}$$

The resulting equation is *not* equivalent to the original equation, so the graph is *not* symmetric with respect to the y -axis.

Origin: We replace x with $-x$ and y with $-y$:

$$\begin{aligned} -y &= 2(-x)^3 \\ -y &= -2x^3 \\ y &= 2x^3. \end{aligned}$$

The resulting equation is equivalent to the original equation, so the graph is symmetric with respect to the origin.

Determine whether each function is even, odd, or neither.

a) $g(x) = 2x^2 - 4$ b) $h(x) = x^5 - 3x^3 - x$

a) We first find $g(-x)$ and simplify:

$$\begin{aligned} g(-x) &= 2(-x)^2 - 4 \\ &= 2x^2 - 4. \end{aligned}$$

$g(x) = g(-x)$, so g is even. Since a function other than $f(x) = 0$ cannot be *both* even and odd and g is even, we need not test to see if it is an odd function.

b) We first find $h(-x)$ and simplify:

$$\begin{aligned} h(-x) &= (-x)^5 - 3(-x)^3 - (-x) \\ &= -x^5 + 3x^3 + x. \end{aligned}$$

$h(x) \neq h(-x)$, so h is *not* even.

Next, we find $-h(x)$ and simplify:

$$\begin{aligned} -h(x) &= -(x^5 - 3x^3 - x) \\ &= -x^5 + 3x^3 + x. \end{aligned}$$

$h(-x) = -h(x)$, so h is odd.

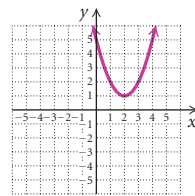
Vertical TranslationFor $b > 0$:the graph of $y = f(x) + b$ is the graph of $y = f(x)$ shifted *up* b units;the graph of $y = f(x) - b$ is the graph of $y = f(x)$ shifted *down* b units.**Horizontal Translation**For $d > 0$:the graph of $y = f(x - d)$ is the graph of $y = f(x)$ shifted *right* d units;the graph of $y = f(x + d)$ is the graph of $y = f(x)$ shifted *left* d units.**Reflections**The graph of $y = -f(x)$ is the **reflection** of $y = f(x)$ across the x -axis.The graph of $y = f(-x)$ is the **reflection** of $y = f(x)$ across the y -axis.If a point (x, y) is on the graph of $y = f(x)$, then $(x, -y)$ is on the graph of $y = -f(x)$, and $(-x, y)$ is on the graph of $y = f(-x)$.Graph $g(x) = (x - 2)^2 + 1$. Before doing so, describe how the graph can be obtained from the graph of $f(x) = x^2$.First, note that the graph of $h(x) = (x - 2)^2$ is the graph of $f(x) = x^2$ shifted right 2 units. Then the graph of $g(x) = (x - 2)^2 + 1$ is the graph of $h(x) = (x - 2)^2$ shifted up 1 unit. Thus the graph of g is obtained by shifting the graph of $f(x) = x^2$ right 2 units and up 1 unit.

$$g(x) = (x - 2)^2 + 1$$

Graph each of the following. Before doing so, describe how each graph can be obtained from the graph of $f(x) = x^2 - x$.

a) $g(x) = x - x^2$ b) $h(x) = (-x)^2 - (-x)$

a) Note that

$$\begin{aligned} -f(x) &= -(x^2 - x) \\ &= -x^2 + x \\ &= x - x^2 \\ &= g(x). \end{aligned}$$

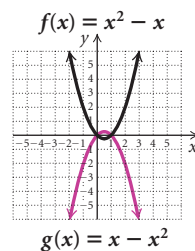
Thus the graph is a reflection of the graph of $f(x) = x^2 - x$ across the x -axis.

b) Note that

$$f(-x) = (-x)^2 - (-x) = h(x).$$

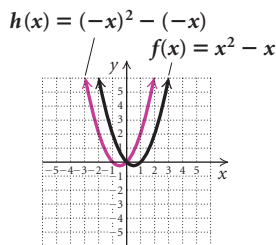
Thus the graph of $h(x) = (-x)^2 - (-x)$ is a reflection of the graph of $f(x) = x^2 - x$ across the y -axis.

Vertical Stretching and Shrinking

The graph of $y = af(x)$ can be obtained from the graph of $y = f(x)$ by:

- stretching vertically for $|a| > 1$, or
- shrinking vertically for $0 < |a| < 1$.

For $a < 0$, the graph is also reflected across the x -axis.

(The y -coordinates of the graph of $y = af(x)$ can be obtained by multiplying the y -coordinates of $y = f(x)$ by a .)

Horizontal Stretching and Shrinking

The graph of $y = f(cx)$ can be obtained from the graph of $y = f(x)$ by:

- shrinking horizontally for $|c| > 1$, or
- stretching horizontally for $0 < |c| < 1$.

For $c < 0$, the graph is also reflected across the y -axis.

(The x -coordinates of the graph of $y = f(cx)$ can be obtained by dividing the x -coordinates of $y = f(x)$ by c .)

A graph of $y = g(x)$ is shown below. Use this graph to graph each of the given equations.

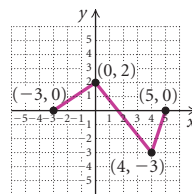

- a) $f(x) = g(2x)$ b) $f(x) = -2g(x)$
 c) $f(x) = \frac{1}{2}g(x)$ d) $f(x) = g\left(\frac{1}{2}x\right)$

- a) Since $|2| > 1$, the graph of $f(x) = g(2x)$ is a horizontal shrinking of the graph of $y = g(x)$. The transformation divides each x -coordinate of g by 2.

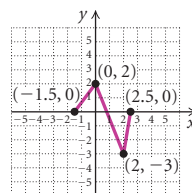

- b) Since $|-2| > 1$, the graph of $f(x) = -2g(x)$ is a vertical stretching of the graph of $y = g(x)$. The transformation multiplies each y -coordinate of g by 2. Since $-2 < 0$, the graph is also reflected across the x -axis.

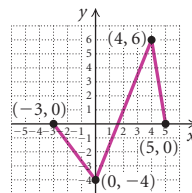

- c) Since $|\frac{1}{2}| < 1$, the graph of $f(x) = \frac{1}{2}g(x)$ is a vertical shrinking of the graph of $y = g(x)$. The transformation multiplies each y -coordinate of g by $\frac{1}{2}$.

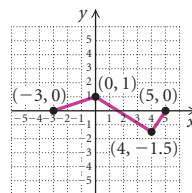

(Continued)

- d) Since $|\frac{1}{2}| < 1$, the graph of $f(x) = g(\frac{1}{2}x)$ is a horizontal stretching of the graph of $y = g(x)$. The transformation divides each x -coordinate of g by $\frac{1}{2}$ (which is the same as multiplying by 2).

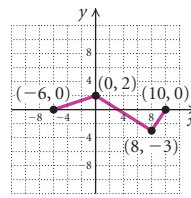

SECTION 2.5: VARIATION AND APPLICATIONS

Direct Variation

If a situation gives rise to a linear function $f(x) = kx$, or $y = kx$, where k is a positive constant, we say that we have **direct variation**, or that y **varies directly as x** , or that y is **directly proportional to x** . The number k is called the **variation constant**, or the **constant of proportionality**.

Find an equation of variation in which y varies directly as x , and $y = 24$ when $x = 8$. Then find the value of y when $x = 5$.

$$\begin{aligned} y &= kx && \text{y varies directly as x.} \\ 24 &= k \cdot 8 && \text{Substituting} \\ 3 &= k && \text{Variation constant} \end{aligned}$$

The equation of variation is $y = 3x$. Now we use the equation to find the value of y when $x = 5$:

$$\begin{aligned} y &= 3x \\ y &= 3 \cdot 5 && \text{Substituting} \\ y &= 15. \end{aligned}$$

When $x = 5$, the value of y is 15.

Inverse Variation

If a situation gives rise to a linear function $f(x) = k/x$, or $y = k/x$, where k is a positive constant, we say that we have **inverse variation**, or that y **varies inversely as x** , or that y is **inversely proportional to x** . The number k is called the **variation constant**, or the **constant of proportionality**.

Find an equation of variation in which y varies inversely as x , and $y = 5$ when $x = 0.1$. Then find the value of y when $x = 10$.

$$\begin{aligned} y &= \frac{k}{x} && \text{y varies inversely as x.} \\ 5 &= \frac{k}{0.1} && \text{Substituting} \\ 0.5 &= k && \text{Variation constant} \end{aligned}$$

The equation of variation is $y = \frac{0.5}{x}$. Now we use the equation to find the value of y when $x = 10$:

$$\begin{aligned} y &= \frac{0.5}{x} \\ y &= \frac{0.5}{10} && \text{Substituting} \\ y &= 0.05. \end{aligned}$$

When $x = 10$, the value of y is 0.05.

Combined Variation

y varies **directly as the n th power of x** if there is some positive constant k such that

$$y = kx^n.$$

y varies **inversely as the n th power of x** if there is some positive constant k such that

$$y = \frac{k}{x^n}.$$

y varies **jointly as x and z** if there is some positive constant k such that

$$y = kxz.$$

Find an equation of variation in which y varies jointly as w and the square of x and inversely as z , and $y = 8$ when $w = 3$, $x = 2$, and $z = 6$.

$$y = k \cdot \frac{wx^2}{z}$$

$$8 = k \cdot \frac{3 \cdot 2^2}{6}$$

Substituting

$$8 = k \cdot \frac{3 \cdot 4}{6}$$

$$8 = 2k$$

$$4 = k$$

Variation constant

The equation of variation is $y = 4 \frac{wx^2}{z}$, or $y = \frac{4wx^2}{z}$.

REVIEW EXERCISES

Determine whether the statement is true or false.

- The greatest integer function pairs each input with the greatest integer less than or equal to that input. [2.1]
- In general, for functions f and g , the domain of $f \circ g =$ the domain of $g \circ f$. [2.3]
- The graph of $y = (x - 2)^2$ is the graph of $y = x^2$ shifted right 2 units. [2.4]
- The graph of $y = -x^2$ is the reflection of the graph of $y = x^2$ across the x -axis. [2.4]

Determine the intervals on which the function is (a) increasing, (b) decreasing, and (c) constant. [2.1]

5.

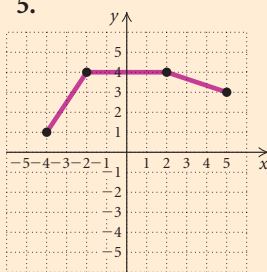

6.

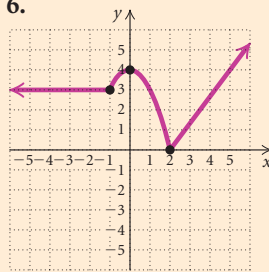

Graph the function. Estimate the intervals on which the function is increasing or decreasing and estimate any relative maxima or minima. [2.1]

7. $f(x) = x^2 - 1$ 8. $f(x) = 2 - |x|$

- Tablecloth Area.** A seamstress uses 20 ft of lace to trim the edges of a rectangular tablecloth. If the tablecloth is l feet long, express its area as a function of the length. [2.1]

- Inscribed Rectangle.** A rectangle is inscribed in a semicircle of radius 2, as shown. The variable $x =$ half the length of the rectangle. Express the area of the rectangle as a function of x . [2.1]

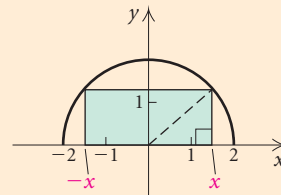

11. **Minimizing Surface Area.** A container firm is designing an open-top rectangular box, with a square base, that will hold 108 in^3 . Let x = the length of a side of the base.

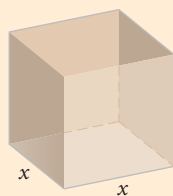

- a) Express the surface area as a function of x . [2.1]
 b) Find the domain of the function. [2.1]
 c) Using the graph below, determine the dimensions that will minimize the surface area of the box. [2.1]

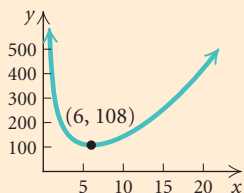

Graph each of the following. [2.1]

12. $f(x) = \begin{cases} -x, & \text{for } x \leq -4, \\ \frac{1}{2}x + 1, & \text{for } x > -4 \end{cases}$
 13. $f(x) = \begin{cases} x^3, & \text{for } x < -2, \\ |x|, & \text{for } -2 \leq x \leq 2, \\ \sqrt{x-1}, & \text{for } x > 2 \end{cases}$
 14. $f(x) = \begin{cases} \frac{x^2 - 1}{x + 1}, & \text{for } x \neq -1, \\ 3, & \text{for } x = -1 \end{cases}$
 15. $f(x) = \llbracket x \rrbracket$ 16. $f(x) = \llbracket x - 3 \rrbracket$
 17. For the function in Exercise 13, find $f(-1)$, $f(5)$, $f(-2)$, and $f(-3)$. [2.1]
 18. For the function in Exercise 14, find $f(-2)$, $f(-1)$, $f(0)$, and $f(4)$. [2.1]

Given that $f(x) = \sqrt{x-2}$ and $g(x) = x^2 - 1$, find each of the following if it exists. [2.2]

19. $(f - g)(6)$ 20. $(fg)(2)$
 21. $(f + g)(-1)$

For each pair of functions in Exercises 22 and 23:

- a) Find the domains of f , g , $f + g$, $f - g$, fg , and f/g . [2.2]
 b) Find $(f + g)(x)$, $(f - g)(x)$, $(fg)(x)$, and $(f/g)(x)$. [2.2]

22. $f(x) = \frac{4}{x^2}$, $g(x) = 3 - 2x$

23. $f(x) = 3x^2 + 4x$, $g(x) = 2x - 1$

24. Given the total-revenue and total-cost functions $R(x) = 120x - 0.5x^2$ and $C(x) = 15x + 6$, find the total-profit function $P(x)$. [2.2]

For each function f , construct and simplify the difference quotient. [2.2]

25. $f(x) = 2x + 7$ 26. $f(x) = 3 - x^2$

27. $f(x) = \frac{4}{x}$

Given that $f(x) = 2x - 1$, $g(x) = x^2 + 4$, and $h(x) = 3 - x^3$, find each of the following. [2.3]

28. $(f \circ g)(1)$ 29. $(g \circ f)(1)$
 30. $(h \circ f)(-2)$ 31. $(g \circ h)(3)$
 32. $(f \circ h)(-1)$ 33. $(h \circ g)(2)$
 34. $(f \circ f)(x)$ 35. $(h \circ h)(x)$

In Exercises 36 and 37, for the pair of functions:

- a) Find $(f \circ g)(x)$ and $(g \circ f)(x)$. [2.3]
 b) Find the domain of $f \circ g$ and the domain of $g \circ f$. [2.3]

36. $f(x) = \frac{4}{x^2}$, $g(x) = 3 - 2x$

37. $f(x) = 3x^2 + 4x$, $g(x) = 2x - 1$

Find $f(x)$ and $g(x)$ such that $h(x) = (f \circ g)(x)$. [2.3]

38. $h(x) = \sqrt{5x + 2}$
 39. $h(x) = 4(5x - 1)^2 + 9$

Graph the given equation and determine visually whether it is symmetric with respect to the x -axis, the y -axis, and the origin. Then verify your assertion algebraically. [2.4]

40. $x^2 + y^2 = 4$ 41. $y^2 = x^2 + 3$
 42. $x + y = 3$ 43. $y = x^2$
 44. $y = x^3$ 45. $y = x^4 - x^2$

Determine visually whether the function is even, odd, or neither even nor odd. [2.4]

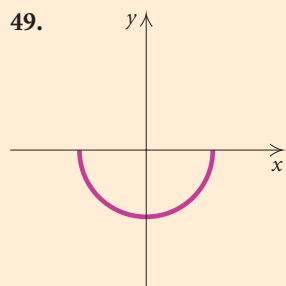
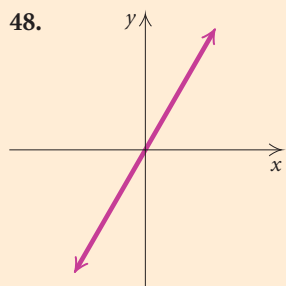
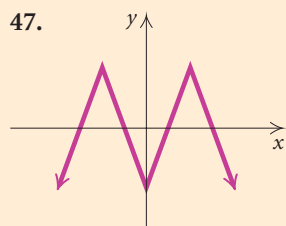
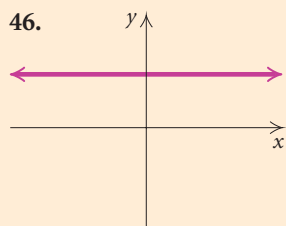

Test whether the function is even, odd, or neither even nor odd. [2.4]

50. $f(x) = 9 - x^2$

51. $f(x) = x^3 - 2x + 4$

52. $f(x) = x^7 - x^5$

53. $f(x) = |x|$

54. $f(x) = \sqrt{16 - x^2}$

55. $f(x) = \frac{10x}{x^2 + 1}$

Write an equation for a function that has a graph with the given characteristics. [2.4]

56. The shape of $y = x^2$, but shifted left 3 units

57. The shape of $y = \sqrt{x}$, but upside down and shifted right 3 units and up 4 units

58. The shape of $y = |x|$, but stretched vertically by a factor of 2 and shifted right 3 units

A graph of $y = f(x)$ is shown below. No formula for f is given. Graph each of the following. [2.4]

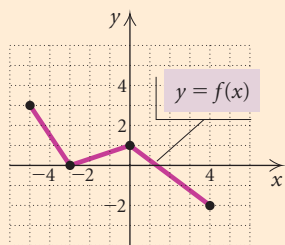

59. $y = f(x - 1)$

60. $y = f(2x)$

61. $y = -2f(x)$

62. $y = 3 + f(x)$

Find an equation of variation for the given situation. [2.5]

63. y varies directly as x , and $y = 100$ when $x = 25$.

64. y varies directly as x , and $y = 6$ when $x = 9$.

65. y varies inversely as x , and $y = 100$ when $x = 25$.

66. y varies inversely as x , and $y = 6$ when $x = 9$.

67. y varies inversely as the square of x , and $y = 12$ when $x = 2$.

68. y varies jointly as x and the square of z and inversely as w , and $y = 2$ when $x = 16$, $w = 0.2$, and $z = \frac{1}{2}$.

69. **Pumping Time.** The time t required to empty a tank varies inversely as the rate r of pumping. If a pump can empty a tank in 35 min at the rate of 800 kL/min, how long will it take the pump to empty the same tank at the rate of 1400 kL/min? [2.5]

70. **Test Score.** The score N on a test varies directly as the number of correct responses a . Ellen answers 29 questions correctly and earns a score of 87. What would Ellen's score have been if she had answered 25 questions correctly? [2.5]

71. **Power of Electric Current.** The power P expended by heat in an electric circuit of fixed resistance varies directly as the square of the current C in the circuit. A circuit expends 180 watts when a current of 6 amperes is flowing. What is the amount of heat expended when the current is 10 amperes? [2.5]

72. For $f(x) = x + 1$ and $g(x) = \sqrt{x}$, the domain of $(g \circ f)(x)$ is which of the following? [2.3]
 A. $[-1, \infty)$
 B. $[-1, 0)$
 C. $[0, \infty)$
 D. $(-\infty, \infty)$

73. For $b > 0$, the graph of $y = f(x) + b$ is the graph of $y = f(x)$ shifted in which of the following ways? [2.4]
 A. Right b units
 B. Left b units
 C. Up b units
 D. Down b units

74. The graph of the function f is shown below.

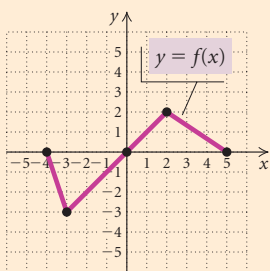

The graph of $g(x) = -\frac{1}{2}f(x) + 1$ is which of the following? [2.4]

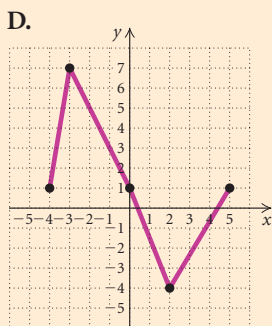
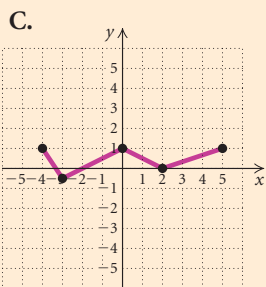
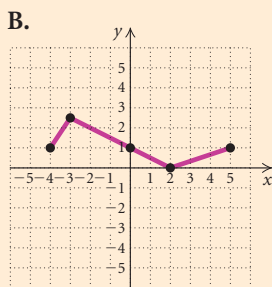
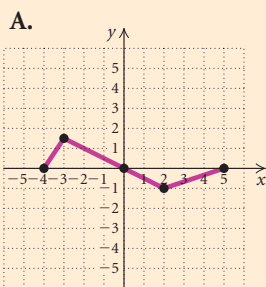

Synthesis

75. Prove that the sum of two odd functions is odd. [2.2], [2.4]
76. Describe how the graph of $y = -f(-x)$ is obtained from the graph of $y = f(x)$. [2.4]

Collaborative Discussion and Writing

77. Given that $f(x) = 4x^3 - 2x + 7$, find each of the following. Then discuss how each expression differs from the other. [1.2], [2.4]
- $f(x) + 2$
 - $f(x + 2)$
 - $f(x) + f(2)$
78. Given the graph of $y = f(x)$, explain and contrast the effect of the constant c on the graphs of $y = f(cx)$ and $y = cf(x)$. [2.4]
79. Consider the constant function $f(x) = 0$. Determine whether the graph of this function is symmetric with respect to the x -axis, the y -axis, and/or the origin. Determine whether this function is even or odd. [2.4]
80. Describe conditions under which you would know whether a polynomial function $f(x) = a_nx^n + a_{n-1}x^{n-1} + \cdots + a_2x^2 + a_1x + a_0$ is even or odd without using an algebraic procedure. Explain. [2.4]
81. If y varies directly as x^2 , explain why doubling x would not cause y to be doubled as well. [2.5]
82. If y varies directly as x and x varies inversely as z , how does y vary with regard to z ? Why? [2.5]

Chapter 2 Test

1. Determine the intervals on which the function is
(a) increasing; (b) decreasing; (c) constant.

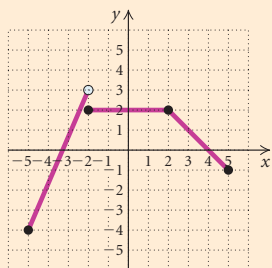

2. Graph the function $f(x) = 2 - x^2$. Estimate the intervals on which the function is increasing or decreasing and estimate any relative maxima or minima.
3. **Triangular Pennant.** A softball team is designing a triangular pennant such that the height is 6 in. less than four times the length of the base b . Express the area of the pennant as a function of b .
4. Graph:

$$f(x) = \begin{cases} x^2, & \text{for } x < -1, \\ |x|, & \text{for } -1 \leq x \leq 1, \\ \sqrt{x-1}, & \text{for } x > 1. \end{cases}$$

5. For the function in Exercise 4, find $f(-\frac{7}{8})$, $f(5)$, and $f(-4)$.

Given that $f(x) = x^2 - 4x + 3$ and $g(x) = \sqrt{3-x}$, find each of the following, if it exists.

6. $(f + g)(-6)$
7. $(f - g)(-1)$
8. $(fg)(2)$
9. $(f/g)(1)$

For $f(x) = x^2$ and $g(x) = \sqrt{x-3}$, find each of the following.

10. The domain of f
11. The domain of g

12. The domain of $f + g$
13. The domain of $f - g$
14. The domain of fg
15. The domain of f/g
16. $(f + g)(x)$
17. $(f - g)(x)$
18. $(fg)(x)$
19. $(f/g)(x)$

For each function, construct and simplify the difference quotient.

20. $f(x) = \frac{1}{2}x + 4$
21. $f(x) = 2x^2 - x + 3$

Given that $f(x) = x^2 - 1$, $g(x) = 4x + 3$, and $h(x) = 3x^2 + 2x + 4$, find each of the following.

22. $(g \circ h)(2)$
23. $(f \circ g)(-1)$
24. $(h \circ f)(1)$
25. $(g \circ g)(x)$

For $f(x) = \sqrt{x-5}$ and $g(x) = x^2 + 1$:

26. Find $(f \circ g)(x)$ and $(g \circ f)(x)$.
27. Find the domain of $(f \circ g)(x)$ and the domain of $(g \circ f)(x)$.
28. Find $f(x)$ and $g(x)$ such that $h(x) = (f \circ g)(x) = (2x - 7)^4$.
29. Determine whether the graph of $y = x^4 - 2x^2$ is symmetric with respect to the x -axis, the y -axis, and the origin.
30. Test whether the function

$$f(x) = \frac{2x}{x^2 + 1}$$

is even, odd, or neither even nor odd. Show your work.

31. Write an equation for a function that has the shape of $y = x^2$, but shifted right 2 units and down 1 unit.
32. Write an equation for a function that has the shape of $y = x^2$, but shifted left 2 units and down 3 units.
33. The graph of a function $y = f(x)$ is shown below. No formula for f is given. Graph $y = -\frac{1}{2}f(x)$.

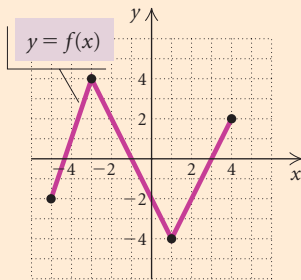

34. Find an equation of variation in which y varies inversely as x , and $y = 5$ when $x = 6$.
35. Find an equation of variation in which y varies directly as x , and $y = 60$ when $x = 12$.
36. Find an equation of variation where y varies jointly as x and the square of z and inversely as w , and $y = 100$ when $x = 0.1$, $z = 10$, and $w = 5$.
37. The stopping distance d of a car after the brakes have been applied varies directly as the square of the speed r . If a car traveling 60 mph can stop in 200 ft, how long will it take a car traveling 30 mph to stop?

38. The graph of the function f is shown below.

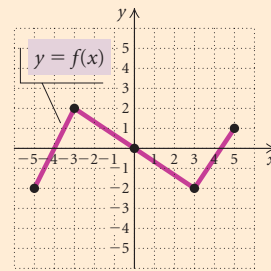

The graph of $g(x) = 2f(x) - 1$ is which of the following?

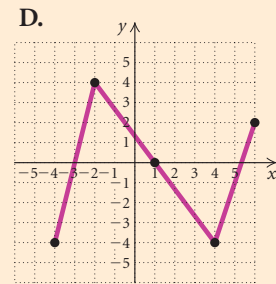
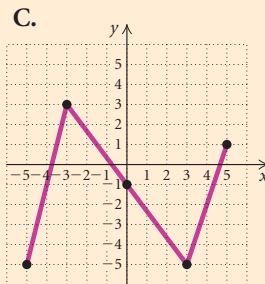
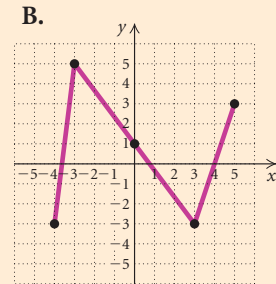
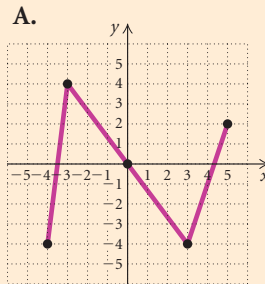

Synthesis

39. If $(-3, 1)$ is a point on the graph of $y = f(x)$, what point do you know is on the graph of $y = f(3x)$?

Quadratic Functions and Equations; Inequalities

CHAPTER

3



Application

After declining between 1940 and 1980, the number of multi-generational American households has been increasing since 1980. The function $h(x) = 0.012x^2 - 0.583x + 35.727$ can be used to estimate the number of multigenerational households in the United States, in millions, x years after 1940 (*Source: Pew Research Center*). In what year were there 40 million multigenerational households?

This problem appears as Exercise 95 in Section 3.2.

- 3.1** The Complex Numbers
- 3.2** Quadratic Equations, Functions, Zeros, and Models
- 3.3** Analyzing Graphs of Quadratic Functions

Visualizing the Graph

Mid-Chapter Mixed Review

- 3.4** Solving Rational Equations and Radical Equations
- 3.5** Solving Equations and Inequalities with Absolute Value

Study Guide

Review Exercises

Chapter Test

The Complex Numbers

3.1

► Perform computations involving complex numbers.

Some functions have zeros that are not real numbers. In order to find the zeros of such functions, we must consider the **complex-number system**.

► The Complex-Number System

We know that the square root of a negative number is not a real number. For example, $\sqrt{-1}$ is not a real number because there is no real number x such that $x^2 = -1$. This means that certain equations, like $x^2 = -1$, or $x^2 + 1 = 0$, do not have real-number solutions, and certain functions, like $f(x) = x^2 + 1$, do not have real-number zeros. Consider the graph of $f(x) = x^2 + 1$.

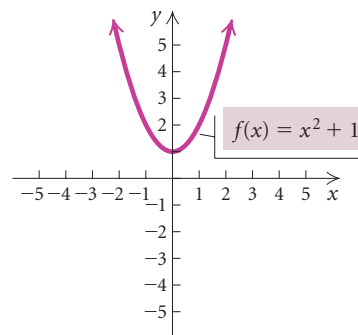

RADICAL EXPRESSIONS

REVIEW SECTION R.7

We see that the graph does not cross the x -axis and thus has no x -intercepts. This illustrates that the function $f(x) = x^2 + 1$ has no real-number zeros. Thus there are no real-number solutions of the corresponding equation $x^2 + 1 = 0$.

We can define a non-real number that is a solution of the equation $x^2 + 1 = 0$.

The Number i

The number i is defined such that

$$i = \sqrt{-1} \quad \text{and} \quad i^2 = -1.$$

To express roots of negative numbers in terms of i , we can use the fact that

$$\sqrt{-p} = \sqrt{-1 \cdot p} = \sqrt{-1} \cdot \sqrt{p} = i\sqrt{p}$$

when p is a positive real number.

STUDY TIP

Don't hesitate to ask questions in class at appropriate times. Most instructors welcome questions and encourage students to ask them. Other students in your class probably have the same questions you do.

EXAMPLE 1 Express each number in terms of i .

- a) $\sqrt{-7}$ b) $\sqrt{-16}$ c) $-\sqrt{-13}$
 d) $-\sqrt{-64}$ e) $\sqrt{-48}$

Solution

$$\begin{aligned} \text{a) } \sqrt{-7} &= \sqrt{-1 \cdot 7} = \sqrt{-1} \cdot \sqrt{7} \\ &= i\sqrt{7}, \text{ or } \sqrt{7}i \end{aligned}$$

$$\begin{aligned} \text{b) } \sqrt{-16} &= \sqrt{-1 \cdot 16} = \sqrt{-1} \cdot \sqrt{16} \\ &= i \cdot 4 = 4i \end{aligned}$$

$$\begin{aligned} \text{c) } -\sqrt{-13} &= -\sqrt{-1 \cdot 13} = -\sqrt{-1} \cdot \sqrt{13} \\ &= -i\sqrt{13}, \text{ or } -\sqrt{13}i \end{aligned}$$

$$\begin{aligned} \text{d) } -\sqrt{-64} &= -\sqrt{-1 \cdot 64} = -\sqrt{-1} \cdot \sqrt{64} \\ &= -i \cdot 8 = -8i \end{aligned}$$

$$\begin{aligned} \text{e) } \sqrt{-48} &= \sqrt{-1 \cdot 48} = \sqrt{-1} \cdot \sqrt{48} \\ &= i\sqrt{16 \cdot 3} \\ &= i \cdot 4\sqrt{3} \\ &= 4i\sqrt{3}, \text{ or } 4\sqrt{3}i \end{aligned}$$

i is not under the radical.

➔ Now Try Exercises 1, 7, and 9.

The complex numbers are formed by adding real numbers and multiples of i .

Complex Numbers

A **complex number** is a number of the form $a + bi$, where a and b are real numbers. The number a is said to be the **real part** of $a + bi$ and the number b is said to be the **imaginary part** of $a + bi$.*

Note that either a or b or both can be 0. When $b = 0$, $a + bi = a + 0i = a$, so every real number is a complex number. A complex number like $3 + 4i$ or $17i$, in which $b \neq 0$, is called an **imaginary number**. A complex number like $17i$ or $-4i$, in which $a = 0$ and $b \neq 0$, is sometimes called a **pure imaginary number**. The relationships among various types of complex numbers are shown in the figure on the following page.

*Sometimes bi is considered to be the imaginary part.

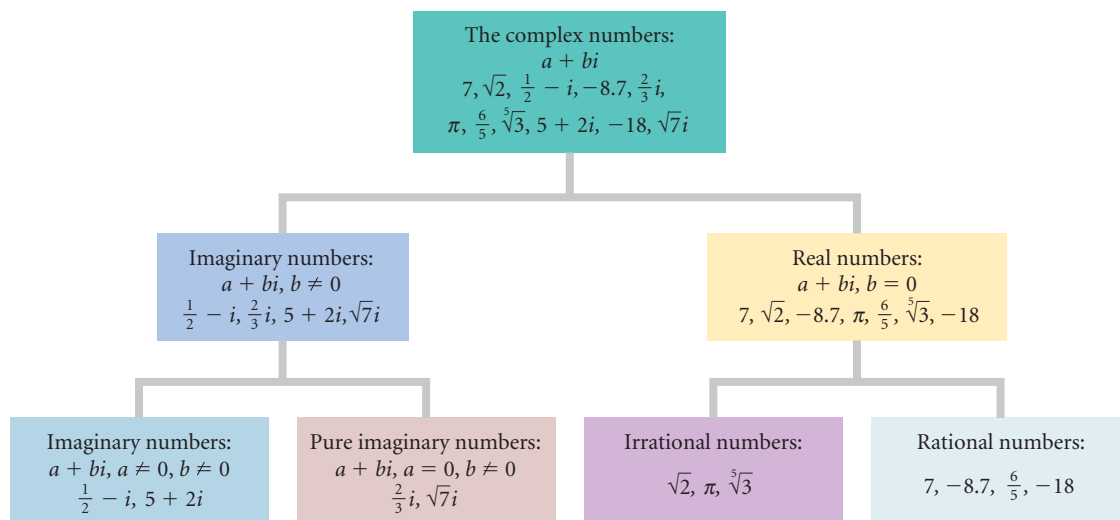

TECHNOLOGY CONNECTION

When set in $a + bi$ mode, most graphing calculators can perform operations on complex numbers. The operations in Example 2 are shown in the window below. Some calculators will express a complex number in the form (a, b) rather than $a + bi$.

$(8+6i)+(3+2i)$	$11+8i$
$(4+5i)-(6-3i)$	$-2+8i$

► Addition and Subtraction

The complex numbers obey the commutative, associative, and distributive laws. Thus we can add and subtract them as we do binomials. We collect the real parts and the imaginary parts of complex numbers just as we collect like terms in binomials.

EXAMPLE 2 Add or subtract and simplify each of the following.

a) $(8 + 6i) + (3 + 2i)$ b) $(4 + 5i) - (6 - 3i)$

Solution

a) $(8 + 6i) + (3 + 2i) = (8 + 3) + (6i + 2i)$

Collecting the real parts and the imaginary parts

$$= 11 + (6 + 2)i = 11 + 8i$$

b) $(4 + 5i) - (6 - 3i) = (4 - 6) + [5i - (-3i)]$

Note that 6 and $-3i$ are both being subtracted.

$$= -2 + 8i$$

➔ **Now Try Exercises 11 and 21.**

► Multiplication

When \sqrt{a} and \sqrt{b} are real numbers, $\sqrt{a} \cdot \sqrt{b} = \sqrt{ab}$, but this is not true when \sqrt{a} and \sqrt{b} are not real numbers. Thus,

$$\begin{aligned}\sqrt{-2} \cdot \sqrt{-5} &= \sqrt{-1} \cdot \sqrt{2} \cdot \sqrt{-1} \cdot \sqrt{5} \\ &= i\sqrt{2} \cdot i\sqrt{5} \\ &= i^2\sqrt{10} = -1\sqrt{10} = -\sqrt{10} \quad \text{is correct!}\end{aligned}$$

But

$$\sqrt{-2} \cdot \sqrt{-5} = \sqrt{(-2)(-5)} = \sqrt{10} \quad \text{is wrong!}$$

Keeping this and the fact that $i^2 = -1$ in mind, we multiply with imaginary numbers in much the same way that we do with real numbers.

EXAMPLE 3 Multiply and simplify each of the following.

a) $\sqrt{-16} \cdot \sqrt{-25}$ b) $(1 + 2i)(1 + 3i)$ c) $(3 - 7i)^2$

Solution

$$\begin{aligned} \text{a) } \sqrt{-16} \cdot \sqrt{-25} &= \sqrt{-1} \cdot \sqrt{16} \cdot \sqrt{-1} \cdot \sqrt{25} \\ &= i \cdot 4 \cdot i \cdot 5 \\ &= i^2 \cdot 20 \\ &= -1 \cdot 20 \quad i^2 = -1 \\ &= -20 \end{aligned}$$

$$\begin{aligned} \text{b) } (1 + 2i)(1 + 3i) &= 1 + 3i + 2i + 6i^2 \\ &= 1 + 3i + 2i - 6 \\ &= -5 + 5i \end{aligned}$$

Multiplying each term of one number by every term of the other (FOIL)
 $i^2 = -1$

Collecting like terms

$$\begin{aligned} \text{c) } (3 - 7i)^2 &= 3^2 - 2 \cdot 3 \cdot 7i + (7i)^2 \\ &= 9 - 42i + 49i^2 \\ &= 9 - 42i - 49 \\ &= -40 - 42i \end{aligned}$$

Recall that $(A - B)^2 = A^2 - 2AB + B^2$.

$i^2 = -1$

 **Now Try Exercises 31 and 39.**

TECHNOLOGY CONNECTION

We can multiply complex numbers on a graphing calculator set in $a + bi$ mode. The products found in Example 3 are shown below.

$\sqrt{-16}\sqrt{-25}$	-20
$(1+2i)(1+3i)$	$-5+5i$
$(3-7i)^2$	$-40-42i$

Recall that -1 raised to an *even* power is 1, and -1 raised to an *odd* power is -1 . Simplifying powers of i can then be done by using the fact that $i^2 = -1$ and expressing the given power of i in terms of i^2 . Consider the following:

$$i = \sqrt{-1},$$

$$i^2 = -1,$$

$$i^3 = i^2 \cdot i = (-1)i = -i,$$

$$i^4 = (i^2)^2 = (-1)^2 = 1,$$

$$i^5 = i^4 \cdot i = (i^2)^2 \cdot i = (-1)^2 \cdot i = 1 \cdot i = i,$$

$$i^6 = (i^2)^3 = (-1)^3 = -1,$$

$$i^7 = i^6 \cdot i = (i^2)^3 \cdot i = (-1)^3 \cdot i = -1 \cdot i = -i,$$

$$i^8 = (i^2)^4 = (-1)^4 = 1.$$

Note that the powers of i cycle through the values i , -1 , $-i$, and 1.

EXAMPLE 6 Divide $2 - 5i$ by $1 - 6i$.

Solution We write fraction notation and then multiply by 1, using the conjugate of the denominator to form the symbol for 1.

$$\begin{aligned} \frac{2 - 5i}{1 - 6i} &= \frac{2 - 5i}{1 - 6i} \cdot \frac{1 + 6i}{1 + 6i} && \text{Note that } 1 + 6i \text{ is the conjugate of} \\ &= \frac{(2 - 5i)(1 + 6i)}{(1 - 6i)(1 + 6i)} && \text{the divisor, } 1 - 6i. \\ &= \frac{2 + 12i - 5i - 30i^2}{1 - 36i^2} \\ &= \frac{2 + 7i + 30}{1 + 36} && i^2 = -1 \\ &= \frac{32 + 7i}{37} \\ &= \frac{32}{37} + \frac{7}{37}i. && \text{Writing the quotient in the} \\ &&& \text{form } a + bi \end{aligned}$$

TECHNOLOGY CONNECTION

With a graphing calculator set in $a + bi$ mode, we can divide complex numbers and express the real and imaginary parts in fraction form, just as we did in Example 6.

$(2-5i)/(1-6i) \blacktriangleright \text{Frac}$
32/37+7/37i

 Now Try Exercise 69.

3.1

Exercise Set

Express the number in terms of i .

- $\sqrt{-3}$
- $\sqrt{-21}$
- $\sqrt{-25}$
- $\sqrt{-100}$
- $-\sqrt{-33}$
- $-\sqrt{-59}$
- $-\sqrt{-81}$
- $-\sqrt{-9}$
- $\sqrt{-98}$
- $\sqrt{-28}$

Simplify. Write answers in the form $a + bi$, where a and b are real numbers.

- $(-5 + 3i) + (7 + 8i)$
- $(-6 - 5i) + (9 + 2i)$
- $(4 - 9i) + (1 - 3i)$
- $(7 - 2i) + (4 - 5i)$
- $(12 + 3i) + (-8 + 5i)$
- $(-11 + 4i) + (6 + 8i)$
- $(-1 - i) + (-3 - i)$
- $(-5 - i) + (6 + 2i)$
- $(3 + \sqrt{-16}) + (2 + \sqrt{-25})$
- $(7 - \sqrt{-36}) + (2 + \sqrt{-9})$
- $(10 + 7i) - (5 + 3i)$
- $(-3 - 4i) - (8 - i)$
- $(13 + 9i) - (8 + 2i)$
- $(-7 + 12i) - (3 - 6i)$
- $(6 - 4i) - (-5 + i)$
- $(8 - 3i) - (9 - i)$
- $(-5 + 2i) - (-4 - 3i)$
- $(-6 + 7i) - (-5 - 2i)$
- $(4 - 9i) - (2 + 3i)$
- $(10 - 4i) - (8 + 2i)$
- $\sqrt{-4} \cdot \sqrt{-36}$
- $\sqrt{-49} \cdot \sqrt{-9}$
- $\sqrt{-81} \cdot \sqrt{-25}$
- $\sqrt{-16} \cdot \sqrt{-100}$
- $7i(2 - 5i)$
- $3i(6 + 4i)$
- $-2i(-8 + 3i)$

38. $-6i(-5 + i)$
 39. $(1 + 3i)(1 - 4i)$
 40. $(1 - 2i)(1 + 3i)$
 41. $(2 + 3i)(2 + 5i)$
 42. $(3 - 5i)(8 - 2i)$
 43. $(-4 + i)(3 - 2i)$
 44. $(5 - 2i)(-1 + i)$
 45. $(8 - 3i)(-2 - 5i)$
 46. $(7 - 4i)(-3 - 3i)$
 47. $(3 + \sqrt{-16})(2 + \sqrt{-25})$
 48. $(7 - \sqrt{-16})(2 + \sqrt{-9})$
 49. $(5 - 4i)(5 + 4i)$
 50. $(5 + 9i)(5 - 9i)$
 51. $(3 + 2i)(3 - 2i)$
 52. $(8 + i)(8 - i)$
 53. $(7 - 5i)(7 + 5i)$
 54. $(6 - 8i)(6 + 8i)$
 55. $(4 + 2i)^2$
 56. $(5 - 4i)^2$
 57. $(-2 + 7i)^2$
 58. $(-3 + 2i)^2$
 59. $(1 - 3i)^2$
 60. $(2 - 5i)^2$
 61. $(-1 - i)^2$
 62. $(-4 - 2i)^2$
 63. $(3 + 4i)^2$
 64. $(6 + 5i)^2$
 65. $\frac{3}{5 - 11i}$
 66. $\frac{i}{2 + i}$
 67. $\frac{5}{2 + 3i}$
 68. $\frac{-3}{4 - 5i}$
 69. $\frac{4 + i}{-3 - 2i}$
 70. $\frac{5 - i}{-7 + 2i}$
 71. $\frac{5 - 3i}{4 + 3i}$
 72. $\frac{6 + 5i}{3 - 4i}$
 73. $\frac{2 + \sqrt{3}i}{5 - 4i}$
 74. $\frac{\sqrt{5} + 3i}{1 - i}$
 75. $\frac{1 + i}{(1 - i)^2}$
 76. $\frac{1 - i}{(1 + i)^2}$
 77. $\frac{4 - 2i}{1 + i} + \frac{2 - 5i}{1 + i}$
 78. $\frac{3 + 2i}{1 - i} + \frac{6 + 2i}{1 - i}$

Simplify.

79. i^{11}
 80. i^7
 81. i^{35}
 82. i^{24}
 83. i^{64}
 84. i^{42}
 85. $(-i)^{71}$
 86. $(-i)^6$
 87. $(5i)^4$
 88. $(2i)^5$

Skill Maintenance

89. Write a slope-intercept equation for the line containing the point $(3, -5)$ and perpendicular to the line $3x - 6y = 7$.

Given that $f(x) = x^2 + 4$ and $g(x) = 3x + 5$, find each of the following.

90. The domain of $f - g$
 91. The domain of f/g
 92. $(f - g)(x)$
 93. $(f/g)(2)$
 94. For the function $f(x) = x^2 - 3x + 4$, construct and simplify the difference quotient

$$\frac{f(x + h) - f(x)}{h}$$

Synthesis

Determine whether each of the following is true or false.

95. The sum of two numbers that are conjugates of each other is always a real number.
 96. The conjugate of a sum is the sum of the conjugates of the individual complex numbers.
 97. The conjugate of a product is the product of the conjugates of the individual complex numbers.

Let $z = a + bi$ and $\bar{z} = a - bi$.

98. Find a general expression for $1/z$.
 99. Find a general expression for $z\bar{z}$.
 100. Solve $z + 6\bar{z} = 7$ for z .
 101. Multiply and simplify:
 $[x - (3 + 4i)][x - (3 - 4i)]$.

Quadratic Equations, Functions, Zeros, and Models

3.2

- ▶ Find zeros of quadratic functions and solve quadratic equations by using the principle of zero products, by using the principle of square roots, by completing the square, and by using the quadratic formula.
- ▶ Solve equations that are reducible to quadratic.
- ▶ Solve applied problems using quadratic equations.

▶ Quadratic Equations and Quadratic Functions

In this section, we will explore the relationship between the solutions of quadratic equations and the zeros of quadratic functions. We define quadratic equations and quadratic functions as follows.

Quadratic Equations

A **quadratic equation** is an equation that can be written in the form

$$ax^2 + bx + c = 0, \quad a \neq 0,$$

where a , b , and c are real numbers.

Quadratic Functions

A **quadratic function** f is a function that can be written in the form

$$f(x) = ax^2 + bx + c, \quad a \neq 0,$$

where a , b , and c are real numbers.

A quadratic equation written in the form $ax^2 + bx + c = 0$ is said to be in **standard form**.

The *zeros* of a quadratic function $f(x) = ax^2 + bx + c$ are the *solutions* of the associated quadratic equation $ax^2 + bx + c = 0$. (These solutions are sometimes called *roots* of the equation.) Quadratic functions can have real-number or imaginary-number zeros and quadratic equations can have real-number or imaginary-number solutions. If the zeros or solutions are real numbers, they are also the first coordinates of the x -intercepts of the graph of the quadratic function.

The following principles allow us to solve many quadratic equations.

Equation-Solving Principles

The Principle of Zero Products: If $ab = 0$ is true, then $a = 0$ or $b = 0$, and if $a = 0$ or $b = 0$, then $ab = 0$.

The Principle of Square Roots: If $x^2 = k$, then $x = \sqrt{k}$ or $x = -\sqrt{k}$.

ZEROS OF A FUNCTION

REVIEW SECTION 1.5

FACTORIZING TRINOMIALS

REVIEW SECTION R.4

EXAMPLE 1 Solve: $2x^2 - x = 3$.**Algebraic Solution**

We have

$$2x^2 - x = 3$$

$$2x^2 - x - 3 = 0 \quad \text{Subtracting 3 on both sides}$$

$$(x + 1)(2x - 3) = 0 \quad \text{Factoring}$$

$$x + 1 = 0 \quad \text{or} \quad 2x - 3 = 0 \quad \text{Using the principle of zero products}$$

$$x = -1 \quad \text{or} \quad 2x = 3$$

$$x = -1 \quad \text{or} \quad x = \frac{3}{2}$$

Check: For $x = -1$:

$$\begin{array}{r} 2x^2 - x = 3 \\ \hline 2(-1)^2 - (-1) \stackrel{?}{=} 3 \\ 2 \cdot 1 + 1 \quad | \\ 2 + 1 \quad | \\ 3 \quad | \quad 3 \quad \text{TRUE} \end{array}$$

For $x = \frac{3}{2}$:

$$\begin{array}{r} 2x^2 - x = 3 \\ \hline 2\left(\frac{3}{2}\right)^2 - \frac{3}{2} \stackrel{?}{=} 3 \\ 2 \cdot \frac{9}{4} - \frac{3}{2} \quad | \\ \frac{9}{2} - \frac{3}{2} \quad | \\ \frac{6}{2} \quad | \\ 3 \quad | \quad 3 \quad \text{TRUE} \end{array}$$

The solutions are -1 and $\frac{3}{2}$.**Visualizing the Solution**

The solutions of the equation $2x^2 - x = 3$, or the equivalent equation $2x^2 - x - 3 = 0$, are the zeros of the function $f(x) = 2x^2 - x - 3$. They are also the first coordinates of the x -intercepts of the graph of $f(x) = 2x^2 - x - 3$.

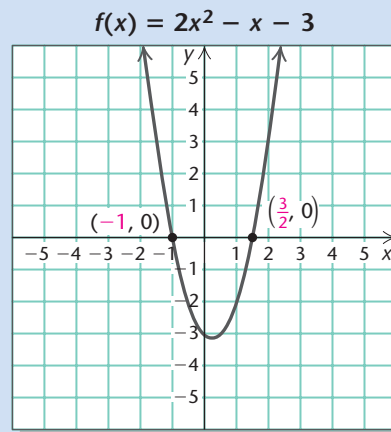
The solutions are -1 and $\frac{3}{2}$.
 Now Try Exercise 3.

EXAMPLE 2 Solve: $2x^2 - 10 = 0$.

Algebraic Solution

We have

$$2x^2 - 10 = 0$$

$$2x^2 = 10$$

$$x^2 = 5$$

$$x = \sqrt{5} \quad \text{or} \quad x = -\sqrt{5}.$$

Adding 10 on both sides

Dividing by 2 on both sides

Using the principle of square roots

Check:

$$2x^2 - 10 = 0$$

$$2(\pm\sqrt{5})^2 - 10 \stackrel{?}{=} 0$$

$$2 \cdot 5 - 10$$

$$10 - 10$$

$$0 = 0$$

We can check both solutions at once.

TRUE

The solutions are $\sqrt{5}$ and $-\sqrt{5}$, or $\pm\sqrt{5}$.

Visualizing the Solution

The solutions of the equation $2x^2 - 10 = 0$ are the zeros of the function $f(x) = 2x^2 - 10$. Note that they are also the first coordinates of the x -intercepts of the graph of $f(x) = 2x^2 - 10$.

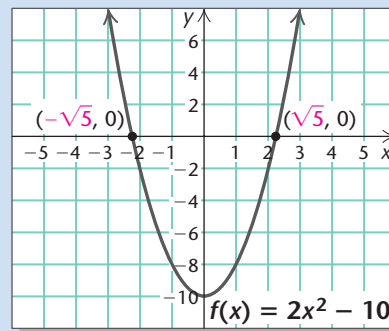

The solutions are $-\sqrt{5}$ and $\sqrt{5}$.

Now Try Exercise 7.

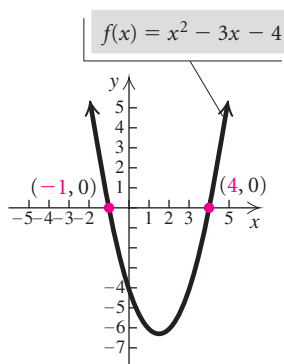

Two real-number zeros
Two x -intercepts

Figure 1

We have seen that some quadratic equations can be solved by factoring and using the principle of zero products. For example, consider the equation $x^2 - 3x - 4 = 0$:

$$x^2 - 3x - 4 = 0$$

$$(x + 1)(x - 4) = 0$$

$$x + 1 = 0 \quad \text{or} \quad x - 4 = 0$$

$$x = -1 \quad \text{or} \quad x = 4.$$

Factoring

Using the principle of zero products

The equation $x^2 - 3x - 4 = 0$ has *two real-number* solutions, -1 and 4 . These are the zeros of the associated quadratic function $f(x) = x^2 - 3x - 4$ and the first coordinates of the x -intercepts of the graph of this function. (See Fig. 1.)

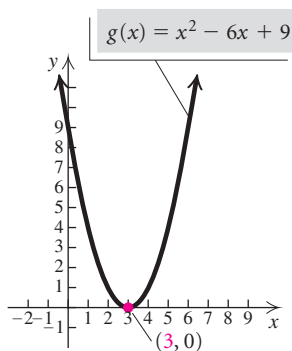

One real-number zero
One x -intercept

Figure 2

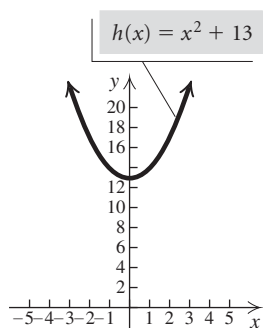

No real-number zeros
No x -intercepts

Figure 3

Next, consider the equation $x^2 - 6x + 9 = 0$. Again, we factor and use the principle of zero products:

$$\begin{aligned}x^2 - 6x + 9 &= 0 \\(x - 3)(x - 3) &= 0 \\x - 3 &= 0 \quad \text{or} \quad x - 3 = 0 \\x &= 3 \quad \text{or} \quad x = 3.\end{aligned}$$

Factoring

Using the principle of zero products

The equation $x^2 - 6x + 9 = 0$ has *one real-number* solution, 3. It is the zero of the quadratic function $g(x) = x^2 - 6x + 9$ and the first coordinate of the x -intercept of the graph of this function. (See Fig. 2.)

The principle of square roots can be used to solve quadratic equations like $x^2 + 13 = 0$:

$$\begin{aligned}x^2 + 13 &= 0 \\x^2 &= -13 \\x &= \pm\sqrt{-13} && \text{Using the principle of square roots} \\x &= \pm\sqrt{13}i && \sqrt{-13} = \sqrt{-1 \cdot 13} = i \cdot \sqrt{13} = \sqrt{13}i\end{aligned}$$

The equation has *two imaginary-number* solutions, $-\sqrt{13}i$ and $\sqrt{13}i$. These are the zeros of the associated quadratic function $h(x) = x^2 + 13$. Since the zeros are not real numbers, the graph of the function has no x -intercepts. (See Fig. 3.)

► Completing the Square

Neither the principle of zero products nor the principle of square roots would yield the *exact* zeros of a function like $f(x) = x^2 - 6x - 10$ or the *exact* solutions of the associated equation $x^2 - 6x - 10 = 0$. If we wish to find exact zeros or solutions, we can use a procedure called **completing the square** and then use the principle of square roots.

EXAMPLE 3 Find the zeros of $f(x) = x^2 - 6x - 10$ by completing the square.

Solution We find the values of x for which $f(x) = 0$; that is, we solve the associated equation $x^2 - 6x - 10 = 0$. Our goal is to find an equivalent equation of the form $x^2 + bx + c = d$ in which $x^2 + bx + c$ is a perfect square. Since

$$x^2 + bx + \left(\frac{b}{2}\right)^2 = \left(x + \frac{b}{2}\right)^2,$$

the number c is found by taking half the coefficient of the x -term and squaring it. Thus for the equation $x^2 - 6x - 10 = 0$, we have

$$\begin{aligned}x^2 - 6x - 10 &= 0 \\x^2 - 6x &= 10 && \text{Adding 10} \\x^2 - 6x + 9 &= 10 + 9 && \text{Adding 9 to complete the square:} \\&&& \left(\frac{b}{2}\right)^2 = \left(\frac{-6}{2}\right)^2 = (-3)^2 = 9 \\x^2 - 6x + 9 &= 19.\end{aligned}$$

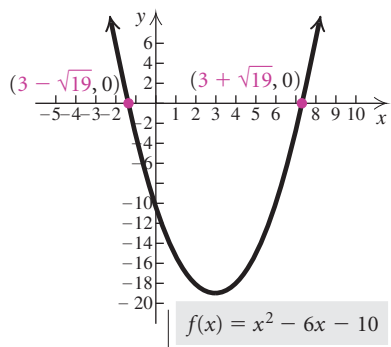

TECHNOLOGY CONNECTION

Approximations for the zeros of the quadratic function

$$f(x) = x^2 - 6x - 10 \text{ in}$$

Example 3 can be found using the Zero method.

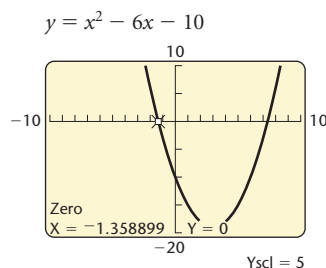
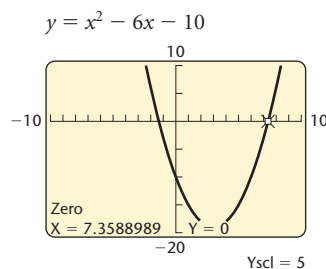

Because $x^2 - 6x + 9$ is a perfect square, we are able to write it as $(x - 3)^2$, the square of a binomial. We can then use the principle of square roots to finish the solution:

$$(x - 3)^2 = 19$$

$$x - 3 = \pm\sqrt{19}$$

$$x = 3 \pm \sqrt{19}$$

Factoring

Using the principle of square roots

Adding 3

Therefore, the solutions of the equation are $3 + \sqrt{19}$ and $3 - \sqrt{19}$, or simply $3 \pm \sqrt{19}$. The zeros of $f(x) = x^2 - 6x - 10$ are also $3 + \sqrt{19}$ and $3 - \sqrt{19}$, or $3 \pm \sqrt{19}$.

Decimal approximations for $3 \pm \sqrt{19}$ can be found using a calculator:

$$3 + \sqrt{19} \approx 7.359 \quad \text{and} \quad 3 - \sqrt{19} \approx -1.359.$$

The zeros are approximately 7.359 and -1.359 .

Now Try Exercise 31.

Before we can complete the square, the coefficient of the x^2 -term must be 1. When it is not, we divide both sides of the equation by the x^2 -coefficient.

EXAMPLE 4 Solve: $2x^2 - 1 = 3x$.

Solution We have

$$2x^2 - 1 = 3x$$

$$2x^2 - 3x - 1 = 0$$

$$2x^2 - 3x = 1$$

$$x^2 - \frac{3}{2}x = \frac{1}{2}$$

$$x^2 - \frac{3}{2}x + \frac{9}{16} = \frac{1}{2} + \frac{9}{16}$$

$$\left(x - \frac{3}{4}\right)^2 = \frac{17}{16}$$

$$x - \frac{3}{4} = \pm \frac{\sqrt{17}}{4}$$

$$x = \frac{3}{4} \pm \frac{\sqrt{17}}{4}$$

$$x = \frac{3 \pm \sqrt{17}}{4}$$

Subtracting $3x$. We are unable to factor the result.

Adding 1

Dividing by 2 to make the x^2 -coefficient 1

Completing the square: $\frac{1}{2}\left(-\frac{3}{2}\right) = -\frac{3}{4}$ and $\left(-\frac{3}{4}\right)^2 = \frac{9}{16}$; adding $\frac{9}{16}$

Factoring and simplifying

Using the principle of square roots and the quotient rule for radicals

Adding $\frac{3}{4}$

The solutions are

$$\frac{3 + \sqrt{17}}{4} \quad \text{and} \quad \frac{3 - \sqrt{17}}{4}, \quad \text{or} \quad \frac{3 \pm \sqrt{17}}{4}.$$

Now Try Exercise 35.

To solve a quadratic equation by completing the square:

1. Isolate the terms with variables on one side of the equation and arrange them in descending order.
2. Divide by the coefficient of the squared term if that coefficient is not 1.
3. Complete the square by taking half the coefficient of the first-degree term and adding its square on both sides of the equation.
4. Express one side of the equation as the square of a binomial.
5. Use the principle of square roots.
6. Solve for the variable.

STUDY TIP

The examples in the text are carefully chosen to prepare you for the exercise sets. Study the step-by-step solutions of the examples, noting that substitutions and explanations appear in red. The time you spend studying the examples will save you valuable time when you do your homework.

► Using the Quadratic Formula

Because completing the square works for *any* quadratic equation, it can be used to solve the general quadratic equation $ax^2 + bx + c = 0$ for x . The result will be a formula that can be used to solve any quadratic equation quickly.

Consider any quadratic equation in standard form:

$$ax^2 + bx + c = 0, \quad a \neq 0.$$

For now, we assume that $a > 0$ and solve by completing the square. As the steps are carried out, compare them with those of Example 4.

$$ax^2 + bx + c = 0 \quad \text{Standard form}$$

$$ax^2 + bx = -c \quad \text{Adding } -c$$

$$x^2 + \frac{b}{a}x = -\frac{c}{a} \quad \text{Dividing by } a$$

Half of $\frac{b}{a}$ is $\frac{b}{2a}$, and $\left(\frac{b}{2a}\right)^2 = \frac{b^2}{4a^2}$. Thus we add $\frac{b^2}{4a^2}$:

$$x^2 + \frac{b}{a}x + \frac{b^2}{4a^2} = -\frac{c}{a} + \frac{b^2}{4a^2} \quad \text{Adding } \frac{b^2}{4a^2} \text{ to complete the square}$$

$$\left(x + \frac{b}{2a}\right)^2 = -\frac{4ac}{4a^2} + \frac{b^2}{4a^2}$$

Factoring on the left; finding a common denominator on the

right: $-\frac{c}{a} = -\frac{c}{a} \cdot \frac{4a}{4a} = -\frac{4ac}{4a^2}$

$$\left(x + \frac{b}{2a}\right)^2 = \frac{b^2 - 4ac}{4a^2}$$

$$x + \frac{b}{2a} = \pm \frac{\sqrt{b^2 - 4ac}}{2a}$$

Using the principle of square roots and the quotient rule for radicals.

Since $a > 0$, $\sqrt{4a^2} = 2a$.

$$x = -\frac{b}{2a} \pm \frac{\sqrt{b^2 - 4ac}}{2a}$$

Adding $-\frac{b}{2a}$

$$x = \frac{-b \pm \sqrt{b^2 - 4ac}}{2a}$$

It can also be shown that this result holds if $a < 0$.

The Quadratic Formula

The solutions of $ax^2 + bx + c = 0$, $a \neq 0$, are given by

$$x = \frac{-b \pm \sqrt{b^2 - 4ac}}{2a}.$$

EXAMPLE 5 Solve $3x^2 + 2x = 7$. Find exact solutions and approximate solutions rounded to three decimal places.

Solution After writing the equation in standard form, we are unable to factor, so we identify a , b , and c in order to use the quadratic formula:

$$3x^2 + 2x = 7$$

$$3x^2 + 2x - 7 = 0;$$

$$a = 3, \quad b = 2, \quad c = -7.$$

We then use the quadratic formula:

$$\begin{aligned} x &= \frac{-b \pm \sqrt{b^2 - 4ac}}{2a} \\ &= \frac{-2 \pm \sqrt{2^2 - 4(3)(-7)}}{2(3)} && \text{Substituting} \\ &= \frac{-2 \pm \sqrt{4 + 84}}{6} = \frac{-2 \pm \sqrt{88}}{6} \\ &= \frac{-2 \pm \sqrt{4 \cdot 22}}{6} = \frac{-2 \pm 2\sqrt{22}}{6} = \frac{2(-1 \pm \sqrt{22})}{2 \cdot 3} \\ &= \frac{2}{2} \cdot \frac{-1 \pm \sqrt{22}}{3} = \frac{-1 \pm \sqrt{22}}{3}. \end{aligned}$$

The exact solutions are

$$\frac{-1 - \sqrt{22}}{3} \quad \text{and} \quad \frac{-1 + \sqrt{22}}{3}.$$

Using a calculator, we approximate the solutions to be -1.897 and 1.230 .

 **Now Try Exercise 41.**

EXAMPLE 6 Solve: $x^2 + 5x + 8 = 0$.**Algebraic Solution**

To find the solutions, we use the quadratic formula. For $x^2 + 5x + 8 = 0$, we have

$$\begin{aligned} a &= 1, \quad b = 5, \quad c = 8; \\ x &= \frac{-b \pm \sqrt{b^2 - 4ac}}{2a} \\ &= \frac{-5 \pm \sqrt{5^2 - 4(1)(8)}}{2 \cdot 1} && \text{Substituting} \\ &= \frac{-5 \pm \sqrt{-7}}{2} && \text{Simplifying} \\ &= \frac{-5 \pm \sqrt{7}i}{2}. \end{aligned}$$

The solutions are $-\frac{5}{2} - \frac{\sqrt{7}}{2}i$ and $-\frac{5}{2} + \frac{\sqrt{7}}{2}i$.

Visualizing the Solution

The graph of the function $f(x) = x^2 + 5x + 8$ has no x -intercepts.

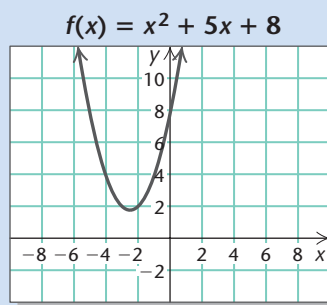

Thus the function has no real-number zeros and there are no real-number solutions of the associated equation $x^2 + 5x + 8 = 0$.

Now Try Exercise 47.

► The Discriminant

From the quadratic formula, we know that the solutions x_1 and x_2 of a quadratic equation are given by

$$x_1 = \frac{-b + \sqrt{b^2 - 4ac}}{2a} \quad \text{and} \quad x_2 = \frac{-b - \sqrt{b^2 - 4ac}}{2a}.$$

The expression $b^2 - 4ac$ shows the nature of the solutions. This expression is called the **discriminant**. If it is 0, then it makes no difference whether we choose the plus sign or the minus sign in the formula. That is,

$x_1 = -\frac{b}{2a} = x_2$, so there is just one solution. In this case, we sometimes

say that there is one repeated real solution. If the discriminant is positive, there will be two real solutions. If it is negative, we will be taking the square root of a negative number; hence there will be two imaginary-number solutions, and they will be complex conjugates.

Discriminant

For $ax^2 + bx + c = 0$, where a , b , and c are real numbers:

$b^2 - 4ac = 0 \rightarrow$ One real-number solution;

$b^2 - 4ac > 0 \rightarrow$ Two different real-number solutions;

$b^2 - 4ac < 0 \rightarrow$ Two different imaginary-number solutions, complex conjugates.

In Example 5, the discriminant, 88, is positive, indicating that there are two different real-number solutions. The negative discriminant, -7 , in Example 6 indicates that there are two different imaginary-number solutions.

► Equations Reducible to Quadratic

Some equations can be treated as quadratic, provided that we make a suitable substitution. For example, consider the following:

$$\begin{aligned} x^4 - 5x^2 + 4 &= 0 \\ (x^2)^2 - 5x^2 + 4 &= 0 & x^4 &= (x^2)^2 \\ \downarrow \quad \downarrow & & & \\ u^2 - 5u + 4 &= 0. & \text{Substituting } u &\text{ for } x^2 \end{aligned}$$

The equation $u^2 - 5u + 4 = 0$ can be solved for u by factoring or using the quadratic formula. Then we can reverse the substitution, replacing u with x^2 , and solve for x . Equations like the one above are said to be **reducible to quadratic**, or **quadratic in form**.

EXAMPLE 7 Solve: $x^4 - 5x^2 + 4 = 0$.

Algebraic Solution

We let $u = x^2$ and substitute:

$$u^2 - 5u + 4 = 0 \quad \text{Substituting } u \text{ for } x^2$$

$$(u - 1)(u - 4) = 0 \quad \text{Factoring}$$

$$u - 1 = 0 \quad \text{or} \quad u - 4 = 0 \quad \text{Using the principle of zero products}$$

$$u = 1 \quad \text{or} \quad u = 4.$$

Don't stop here! We must solve for the original variable.

We substitute x^2 for u and solve for x :

$$x^2 = 1 \quad \text{or} \quad x^2 = 4$$

$$x = \pm 1 \quad \text{or} \quad x = \pm 2. \quad \text{Using the principle of square roots}$$

The solutions are -1 , 1 , -2 , and 2 .

Visualizing the Solution

The solutions of the given equation are the zeros of $f(x) = x^4 - 5x^2 + 4$. Note that the zeros occur at the x -values -2 , -1 , 1 , and 2 .

$$f(x) = x^4 - 5x^2 + 4$$

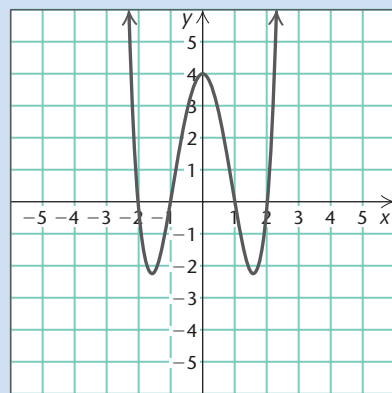

► Now Try Exercise 79.

TECHNOLOGY CONNECTION

We can use the Zero method to solve the equation in Example 7, $x^4 - 5x^2 + 4 = 0$. We graph the function $y = x^4 - 5x^2 + 4$ and use the ZERO feature to find the zeros.

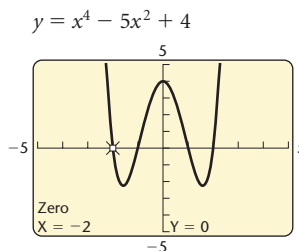

The leftmost zero is -2 . Using the ZERO feature three more times, we find that the other zeros are -1 , 1 , and 2 .

► Applications

Some applied problems can be translated to quadratic equations.



EXAMPLE 8 *Time of a Free Fall.* The Burj Khalifa tower (also known as the Burj Dubai or the Dubai Tower) in the United Arab Emirates is 2717 ft tall. How long would it take an object dropped from the top to reach the ground?

Solution

1. **Familiarize.** The formula $s = 16t^2$ is used to approximate the distance s , in feet, that an object falls freely from rest in t seconds. In this case, the distance is 2717 ft.

2. **Translate.** We substitute 2717 for s in the formula:

$$2717 = 16t^2.$$

3. **Carry out.** We use the principle of square roots:

$$2717 = 16t^2$$

$$\frac{2717}{16} = t^2 \quad \text{Dividing by 16}$$

$$\sqrt{\frac{2717}{16}} = t \quad \text{Taking the positive square root. Time cannot be negative in this application.}$$

$$13.03 \approx t.$$

4. **Check.** In 13.03 sec, a dropped object would travel a distance of $16(13.03)^2$, or about 2717 ft. The answer checks.

5. **State.** It would take about 13.03 sec for an object dropped from the top of the Burj Khalifa to reach the ground. ➔ Now Try Exercise 99.

EXAMPLE 9 *Train Speeds.* Two trains leave a station at the same time. One train travels due west, and the other travels due south. The train traveling west travels 20 km/h faster than the train traveling south. After 2 hr, the trains are 200 km apart. Find the speed of each train.

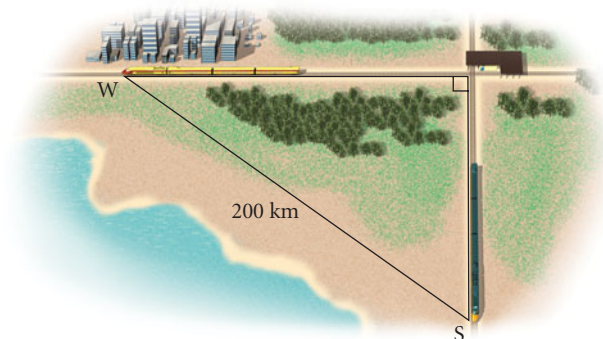

Solution

1. Familiarize. We let r = the speed of the train traveling south, in kilometers per hour. Then $r + 20$ = the speed of the train traveling west, in kilometers per hour. We use the motion formula $d = rt$, where d is the distance, r is the rate (or speed), and t is the time. After 2 hr, the train traveling south has traveled $2r$ kilometers, and the train traveling west has traveled $2(r + 20)$ kilometers. We add these distances to the drawing.

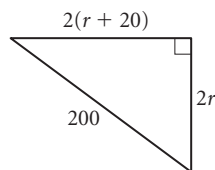

THE PYTHAGOREAN THEOREM

REVIEW SECTION R.7

2. Translate. We use the Pythagorean theorem, $a^2 + b^2 = c^2$, where a and b are the lengths of the legs of a right triangle and c is the length of the hypotenuse:

$$[2(r + 20)]^2 + (2r)^2 = 200^2.$$

3. Carry out. We solve the equation:

$$\begin{aligned} [2(r + 20)]^2 + (2r)^2 &= 200^2 \\ 4(r^2 + 40r + 400) + 4r^2 &= 40,000 \\ 4r^2 + 160r + 1600 + 4r^2 &= 40,000 \\ 8r^2 + 160r + 1600 &= 40,000 \\ 8r^2 + 160r - 38,400 &= 0 \\ r^2 + 20r - 4800 &= 0 \\ (r + 80)(r - 60) &= 0 \\ r + 80 = 0 &\quad \text{or} \quad r - 60 = 0 \\ r = -80 &\quad \text{or} \quad r = 60. \end{aligned}$$

Collecting like terms

Subtracting 40,000

Dividing by 8

Factoring

Principle of zero products

4. **Check.** Since speed cannot be negative, we need check only 60. If the speed of the train traveling south is 60 km/h, then the speed of the train traveling west is $60 + 20$, or 80 km/h. In 2 hr, the train heading south travels $60 \cdot 2$, or 120 km, and the train heading west travels $80 \cdot 2$, or 160 km. Then they are $\sqrt{120^2 + 160^2}$, or $\sqrt{40,000}$, or 200 km apart. The answer checks.
5. **State.** The speed of the train heading south is 60 km/h, and the speed of the train heading west is 80 km/hr.

 **Now Try Exercise 101.**

CONNECTING THE CONCEPTS

Zeros, Solutions, and Intercepts

The zeros of a function $y = f(x)$ are also the solutions of the equation $f(x) = 0$, and the real-number zeros are the first coordinates of the x -intercepts of the graph of the function.

FUNCTION

Linear Function

$$f(x) = 2x - 4, \text{ or}$$

$$y = 2x - 4$$

ZERO OF THE FUNCTION; SOLUTION OF THE EQUATION

To find the **zero** of $f(x)$, we solve $f(x) = 0$:

$$2x - 4 = 0$$

$$2x = 4$$

$$x = 2.$$

The **solution** of the equation $2x - 4 = 0$ is **2**. This is the zero of the function $f(x) = 2x - 4$; that is, $f(2) = 0$.

X-INTERCEPTS OF THE GRAPH

The zero of $f(x)$ is the first coordinate of the **x -intercept** of the graph of $y = f(x)$.

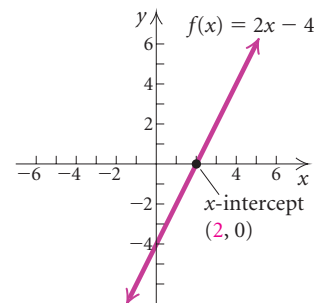

Quadratic Function

$$g(x) = x^2 - 3x - 4, \text{ or}$$

$$y = x^2 - 3x - 4$$

To find the **zeros** of $g(x)$, we solve $g(x) = 0$:

$$x^2 - 3x - 4 = 0$$

$$(x + 1)(x - 4) = 0$$

$$x + 1 = 0 \quad \text{or} \quad x - 4 = 0$$

$$x = -1 \quad \text{or} \quad x = 4.$$

The **solutions** of the equation $x^2 - 3x - 4 = 0$ are **-1** and **4**. They are the zeros of the function $g(x)$; that is, $g(-1) = 0$ and $g(4) = 0$.

The real-number zeros of $g(x)$ are the first coordinates of the **x -intercepts** of the graph of $y = g(x)$.

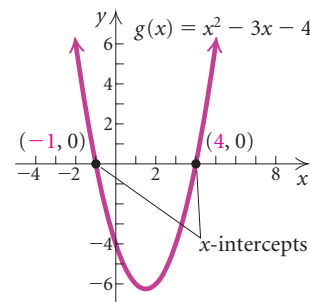

3.2

Exercise Set

Solve.

1. $(2x - 3)(3x - 2) = 0$

2. $(5x - 2)(2x + 3) = 0$

3. $x^2 - 8x - 20 = 0$

4. $x^2 + 6x + 8 = 0$

5. $3x^2 + x - 2 = 0$

6. $10x^2 - 16x + 6 = 0$

7. $4x^2 - 12 = 0$

8. $6x^2 = 36$

9. $3x^2 = 21$

10. $2x^2 - 20 = 0$

11. $5x^2 + 10 = 0$

12. $4x^2 + 12 = 0$

13. $x^2 + 16 = 0$

14. $x^2 + 25 = 0$

15. $2x^2 = 6x$

16. $18x + 9x^2 = 0$

17. $3y^3 - 5y^2 - 2y = 0$

18. $3t^3 + 2t = 5t^2$

19. $7x^3 + x^2 - 7x - 1 = 0$

(Hint: Factor by grouping.)

20. $3x^3 + x^2 - 12x - 4 = 0$

(Hint: Factor by grouping.)

In Exercises 21–28, use the given graph to find each of the following: (a) the x -intercept(s) and (b) the zero(s) of the function.

21.

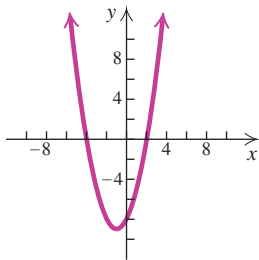

22.

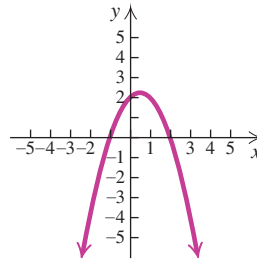

23.

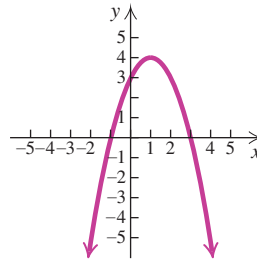

24.

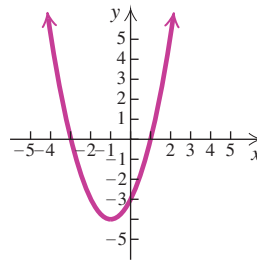

25.

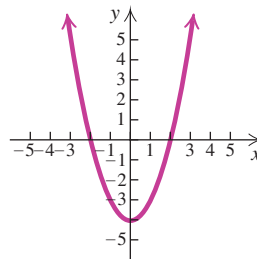

26.

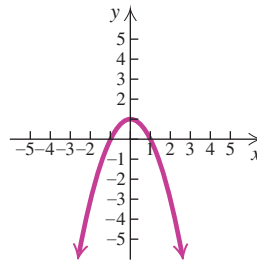

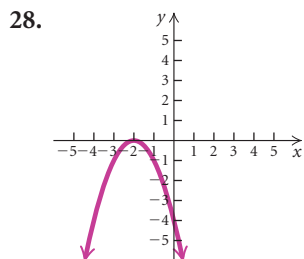
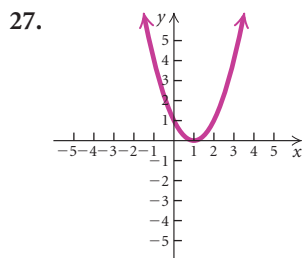

Solve by completing the square to obtain exact solutions.

- | | |
|-------------------------|-------------------------|
| 29. $x^2 + 6x = 7$ | 30. $x^2 + 8x = -15$ |
| 31. $x^2 = 8x - 9$ | 32. $x^2 = 22 + 10x$ |
| 33. $x^2 + 8x + 25 = 0$ | 34. $x^2 + 6x + 13 = 0$ |
| 35. $3x^2 + 5x - 2 = 0$ | 36. $2x^2 - 5x - 3 = 0$ |

Use the quadratic formula to find exact solutions.

- | | |
|------------------------|-------------------------|
| 37. $x^2 - 2x = 15$ | 38. $x^2 + 4x = 5$ |
| 39. $5m^2 + 3m = 2$ | 40. $2y^2 - 3y - 2 = 0$ |
| 41. $3x^2 + 6 = 10x$ | 42. $3t^2 + 8t + 3 = 0$ |
| 43. $x^2 + x + 2 = 0$ | 44. $x^2 + 1 = x$ |
| 45. $5t^2 - 8t = 3$ | 46. $5x^2 + 2 = x$ |
| 47. $3x^2 + 4 = 5x$ | 48. $2t^2 - 5t = 1$ |
| 49. $x^2 - 8x + 5 = 0$ | 50. $x^2 - 6x + 3 = 0$ |
| 51. $3x^2 + x = 5$ | 52. $5x^2 + 3x = 1$ |
| 53. $2x^2 + 1 = 5x$ | 54. $4x^2 + 3 = x$ |
| 55. $5x^2 + 2x = -2$ | 56. $3x^2 + 3x = -4$ |

For each of the following, find the discriminant, $b^2 - 4ac$, and then determine whether one real-number solution, two different real-number solutions, or two different imaginary-number solutions exist.

- | | |
|-------------------------|--------------------------|
| 57. $4x^2 = 8x + 5$ | 58. $4x^2 - 12x + 9 = 0$ |
| 59. $x^2 + 3x + 4 = 0$ | 60. $x^2 - 2x + 4 = 0$ |
| 61. $9x^2 + 6x + 1 = 0$ | 62. $5t^2 - 4t = 11$ |

Find the zeros of the function. Give exact answers and approximate solutions rounded to three decimal places when possible.

- | |
|----------------------------|
| 63. $f(x) = x^2 + 6x + 5$ |
| 64. $f(x) = x^2 - x - 2$ |
| 65. $f(x) = x^2 - 3x - 3$ |
| 66. $f(x) = 3x^2 + 8x + 2$ |
| 67. $f(x) = x^2 - 5x + 1$ |
| 68. $f(x) = x^2 - 3x - 7$ |
| 69. $f(x) = x^2 + 2x - 5$ |
| 70. $f(x) = x^2 - x - 4$ |
| 71. $f(x) = 2x^2 - x + 4$ |
| 72. $f(x) = 2x^2 + 3x + 2$ |
| 73. $f(x) = 3x^2 - x - 1$ |
| 74. $f(x) = 3x^2 + 5x + 1$ |
| 75. $f(x) = 5x^2 - 2x - 1$ |
| 76. $f(x) = 4x^2 - 4x - 5$ |
| 77. $f(x) = 4x^2 + 3x - 3$ |
| 78. $f(x) = x^2 + 6x - 3$ |

Solve.

- | |
|--|
| 79. $x^4 - 3x^2 + 2 = 0$ |
| 80. $x^4 + 3 = 4x^2$ |
| 81. $x^4 + 3x^2 = 10$ |
| 82. $x^4 - 8x^2 = 9$ |
| 83. $y^4 + 4y^2 - 5 = 0$ |
| 84. $y^4 - 15y^2 - 16 = 0$ |
| 85. $x - 3\sqrt{x} - 4 = 0$
(Hint: Let $u = \sqrt{x}$.) |
| 86. $2x - 9\sqrt{x} + 4 = 0$ |
| 87. $m^{2/3} - 2m^{1/3} - 8 = 0$
(Hint: Let $u = m^{1/3}$.) |
| 88. $t^{2/3} + t^{1/3} - 6 = 0$ |
| 89. $x^{1/2} - 3x^{1/4} + 2 = 0$ |
| 90. $x^{1/2} - 4x^{1/4} = -3$ |
| 91. $(2x - 3)^2 - 5(2x - 3) + 6 = 0$
(Hint: Let $u = 2x - 3$.) |
| 92. $(3x + 2)^2 + 7(3x + 2) - 8 = 0$ |

93. $(2t^2 + t)^2 - 4(2t^2 + t) + 3 = 0$

94. $12 = (m^2 - 5m)^2 + (m^2 - 5m)$

Multigenerational Households. After declining between 1940 and 1980, the number of multigenerational American households has been increasing since 1980. The function $h(x) = 0.012x^2 - 0.583x + 35.727$ can be used to estimate the number of multigenerational households in the United States, in millions, x years after 1940 (Source: Pew Research Center). Use this function for Exercises 95 and 96.



95. In what year were there 40 million multigenerational households?

96. In what year were there 55 million multigenerational households?

TV Channels. The number of TV channels that the average U.S. home receives has been soaring in recent years. The function $t(x) = 0.16x^2 + 0.46x + 21.36$ can be used to estimate this number, where x is the number of years after 1985 (Source: Nielsen Media Research, National People Meter Sample). Use this function for Exercises 97 and 98.

97. In what year did the average U.S. household receive 50 channels?

98. In what year did the average U.S. household receive 88 channels?

Time of a Free Fall. The formula $s = 16t^2$ is used to approximate the distance s , in feet, that an object falls freely from rest in t seconds. Use this formula for Exercises 99 and 100.

99. The Taipei 101 Tower, also known as the Taipei Financial Center, in Taipei, Taiwan, is 1670 ft tall.

How long would it take an object dropped from the top to reach the ground?

100. At 630 ft, the Gateway Arch in St. Louis is the tallest man-made monument in the United States. How long would it take an object dropped from the top to reach the ground?



101. The length of a rectangular poster is 1 ft more than the width, and a diagonal of the poster is 5 ft. Find the length and the width.

102. One leg of a right triangle is 7 cm less than the length of the other leg. The length of the hypotenuse is 13 cm. Find the lengths of the legs.

103. One number is 5 greater than another. The product of the numbers is 36. Find the numbers.

104. One number is 6 less than another. The product of the numbers is 72. Find the numbers.

105. **Box Construction.** An open box is made from a 10-cm by 20-cm piece of tin by cutting a square from each corner and folding up the edges. The area of the resulting base is 96 cm^2 . What is the length of the sides of the squares?

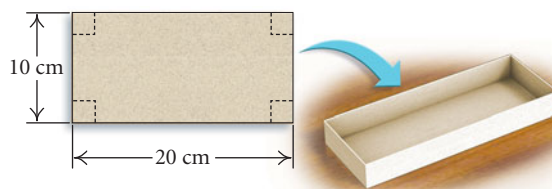

106. **Petting Zoo Dimensions.** At the Glen Island Zoo, 170 m of fencing was used to enclose a petting area of 1750 m^2 . Find the dimensions of the petting area.
107. **Dimensions of a Rug.** Find the dimensions of a Persian rug whose perimeter is 28 ft and whose area is 48 ft^2 .
108. **Picture Frame Dimensions.** The frame on a picture is 8 in. by 10 in. outside and is of uniform width. What is the width of the frame if 48 in^2 of the picture shows?



State whether the function is linear or quadratic.

109. $f(x) = 4 - 5x$ 110. $f(x) = 4 - 5x^2$
 111. $f(x) = 7x^2$ 112. $f(x) = 23x + 6$
 113. $f(x) = 1.2x - (3.6)^2$ 114. $f(x) = 2 - x - x^2$

Skill Maintenance

Spending on Antipsychotic Drugs. The amount of spending on antipsychotic drugs, used to treat schizophrenia and other conditions, recently edged out cholesterol medications at the top of U.S. sales charts. The function $a(x) = 1.24x + 9.24$ can be used to estimate the amount of spending per year on antipsychotic drugs in the United States, in billions of dollars, x years after 2004 (Source: IMS Health). Use this function for Exercises 115 and 116.

115. Estimate the amount spent on antipsychotic drugs in the United States in 2010.
116. When will the amount of spending on antipsychotic drugs reach \$24 billion?

Determine whether the graph is symmetric with respect to the x -axis, the y -axis, and the origin.

117. $3x^2 + 4y^2 = 5$ 118. $y^3 = 6x^2$

Determine whether the function is even, odd, or neither even nor odd.

119. $f(x) = 2x^3 - x$

120. $f(x) = 4x^2 + 2x - 3$

Synthesis

For each equation in Exercises 121–124, under the given condition: (a) Find k and (b) find a second solution.

121. $kx^2 - 17x + 33 = 0$; one solution is 3
 122. $kx^2 - 2x + k = 0$; one solution is -3
 123. $x^2 - kx + 2 = 0$; one solution is $1 + i$
 124. $x^2 - (6 + 3i)x + k = 0$; one solution is 3

Solve.

125. $(x - 2)^3 = x^3 - 2$
 126. $(x + 1)^3 = (x - 1)^3 + 26$
 127. $(6x^3 + 7x^2 - 3x)(x^2 - 7) = 0$
 128. $(x - \frac{1}{5})(x^2 - \frac{1}{4}) + (x - \frac{1}{5})(x^2 + \frac{1}{8}) = 0$
 129. $x^2 + x - \sqrt{2} = 0$
 130. $x^2 + \sqrt{5}x - \sqrt{3} = 0$
 131. $2t^2 + (t - 4)^2 = 5t(t - 4) + 24$
 132. $9t(t + 2) - 3t(t - 2) = 2(t + 4)(t + 6)$
 133. $\sqrt{x - 3} - \sqrt[4]{x - 3} = 2$
 134. $x^2 + 3x + 1 - \sqrt{x^2 + 3x + 1} = 8$
 135. $(y + \frac{2}{y})^2 + 3y + \frac{6}{y} = 4$
 136. Solve $\frac{1}{2}at^2 + v_0t + x_0 = 0$ for t .

Analyzing Graphs of Quadratic Functions

3.3

- ▶ Find the vertex, the axis of symmetry, and the maximum or minimum value of a quadratic function using the method of completing the square.
- ▶ Graph quadratic functions.
- ▶ Solve applied problems involving maximum and minimum function values.

▶ Graphing Quadratic Functions of the Type $f(x) = a(x - h)^2 + k$

The graph of a quadratic function is called a **parabola**. The graph of every parabola evolves from the graph of the squaring function $f(x) = x^2$ using transformations.

We get the graph of $f(x) = a(x - h)^2 + k$ from the graph of $f(x) = x^2$ as follows:

$$f(x) = x^2$$

$$f(x) = ax^2$$

$$f(x) = a(x - h)^2$$

$$f(x) = a(x - h)^2 + k.$$

Vertical stretching or shrinking with a reflection across the x -axis if $a < 0$
Horizontal translation

Vertical translation

Consider the following graphs of the form $f(x) = a(x - h)^2 + k$. The point (h, k) at which the graph turns is called the **vertex**. The maximum or minimum value of $f(x)$ occurs at the vertex. Each graph has a line $x = h$ that is called the **axis of symmetry**.

TRANSFORMATIONS
 REVIEW SECTION 2.4

$$f(x) = 2(x + 3)^2 - 2$$

$$= 2[x - (-3)]^2 + (-2)$$

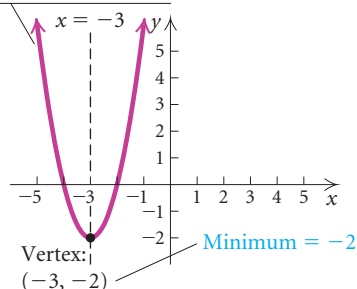

$$f(x) = 2(x - 1)^2 + 3$$

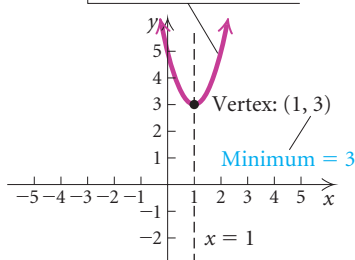

$$f(x) = -2(x - 1)^2 + 3$$

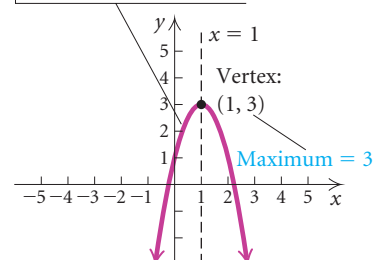

CONNECTING THE CONCEPTS

Graphing Quadratic Functions

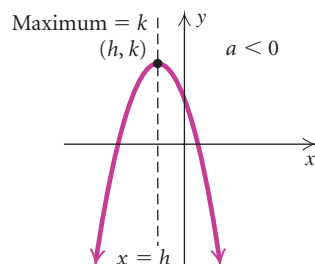
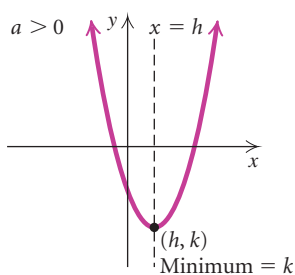

The graph of the function $f(x) = a(x - h)^2 + k$ is a parabola that

- opens up if $a > 0$ and down if $a < 0$;
- has (h, k) as the vertex;
- has $x = h$ as the axis of symmetry;
- has k as a minimum value (output) if $a > 0$;
- has k as a maximum value if $a < 0$.

As we saw in Section 2.4, the constant a serves to stretch or shrink the graph vertically. As a parabola is stretched vertically, it becomes narrower, and as it is shrunk vertically, it becomes wider. That is, as $|a|$ increases, the graph becomes narrower, and as $|a|$ gets close to 0, the graph becomes wider.

If the equation is in the form $f(x) = a(x - h)^2 + k$, we can learn a great deal about the graph without actually graphing the function.

Function	$f(x) = 3\left(x - \frac{1}{4}\right)^2 - 2$ $= 3\left(x - \frac{1}{4}\right)^2 + (-2)$	$g(x) = -3(x + 5)^2 + 7$ $= -3[x - (-5)]^2 + 7$
Vertex	$\left(\frac{1}{4}, -2\right)$	$(-5, 7)$
Axis of Symmetry	$x = \frac{1}{4}$	$x = -5$
Maximum	None ($3 > 0$, so the graph opens up.)	7 ($-3 < 0$, so the graph opens down.)
Minimum	-2 ($3 > 0$, so the graph opens up.)	None ($-3 < 0$, so the graph opens down.)

Note that the vertex (h, k) is used to find the maximum or minimum value of the function. The maximum or minimum value is the number k , not the ordered pair (h, k) .

► Graphing Quadratic Functions of the Type $f(x) = ax^2 + bx + c, a \neq 0$

We now use a modification of the method of completing the square as an aid in graphing and analyzing quadratic functions of the form $f(x) = ax^2 + bx + c, a \neq 0$.

EXAMPLE 1 Find the vertex, the axis of symmetry, and the maximum or minimum value of $f(x) = x^2 + 10x + 23$. Then graph the function.

Solution To express $f(x) = x^2 + 10x + 23$ in the form $f(x) = a(x - h)^2 + k$, we complete the square on the terms involving x . To do so, we take half the coefficient of x and square it, obtaining $(10/2)^2$, or 25. We now add and subtract that number on the *right side*:

$$f(x) = x^2 + 10x + 23 = x^2 + 10x + 25 - 25 + 23.$$

Since $25 - 25 = 0$, the new expression for the function is equivalent to the original expression. Note that this process differs from the one we used to complete the square in order to solve a quadratic equation, where we added the same number on both sides of the equation to obtain an equivalent equation. Instead, when we complete the square to write a function in the form $f(x) = a(x - h)^2 + k$, we add and subtract the same number on the one side. The entire process is shown below:

$$\begin{aligned} f(x) &= x^2 + 10x + 23 \\ &= x^2 + 10x + 25 - 25 + 23 \\ &= (x^2 + 10x + 25) - 25 + 23 \\ &= (x + 5)^2 - 2 \\ &= [x - (-5)]^2 + (-2). \end{aligned}$$

Note that 25 completes the square for $x^2 + 10x$. Adding 25 - 25, or 0, on the right side

Regrouping

Factoring and simplifying

Writing in the form $f(x) = a(x - h)^2 + k$

Keeping in mind that this function will have a minimum value since $a > 0$ ($a = 1$), from this form of the function we know the following:

Vertex: $(-5, -2)$;

Axis of symmetry: $x = -5$;

Minimum value of the function: -2 .

To graph the function, we first plot the vertex and find several points on either side of it. Then we plot these points and connect them with a smooth curve.

x	$f(x)$
-5	-2
-4	-1
-3	2
-6	-1
-7	2

← Vertex

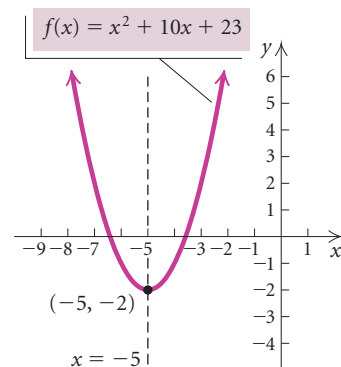

The graph of $f(x) = x^2 + 10x + 23$, or $f(x) = [x - (-5)]^2 + (-2)$, shown above, is a shift of the graph of $y = x^2$ left 5 units and down 2 units.

Keep in mind that the axis of symmetry is not part of the graph; it is a characteristic of the graph. If you fold the graph on its axis of symmetry, the two halves of the graph will coincide.

EXAMPLE 2 Find the vertex, the axis of symmetry, and the maximum or minimum value of $g(x) = x^2/2 - 4x + 8$. Then graph the function.

Solution We complete the square in order to write the function in the form $g(x) = a(x - h)^2 + k$. First, we factor $\frac{1}{2}$ out of the first two terms. This makes the coefficient of x^2 within the parentheses 1:

$$\begin{aligned} g(x) &= \frac{x^2}{2} - 4x + 8 \\ &= \frac{1}{2}(x^2 - 8x) + 8. \end{aligned}$$

Factoring $\frac{1}{2}$ out of the first two terms:
 $\frac{x^2}{2} - 4x = \frac{1}{2} \cdot x^2 - \frac{1}{2} \cdot 8x$

Next, we complete the square inside the parentheses: Half of -8 is -4 , and $(-4)^2 = 16$. We add and subtract 16 inside the parentheses:

$$\begin{aligned} g(x) &= \frac{1}{2}(x^2 - 8x + 16 - 16) + 8 \\ &= \frac{1}{2}(x^2 - 8x + 16) - \frac{1}{2} \cdot 16 + 8 \\ &= \frac{1}{2}(x^2 - 8x + 16) - 8 + 8 \\ &= \frac{1}{2}(x - 4)^2 + 0, \text{ or } \frac{1}{2}(x - 4)^2. \end{aligned}$$

Using the distributive law to remove -16 from within the parentheses

Factoring and simplifying

We know the following:

Vertex: $(4, 0)$;
 Axis of symmetry: $x = 4$;
 Minimum value of the function: 0.

Finally, we plot the vertex and several points on either side of it and draw the graph of the function. The graph of g is a vertical shrinking of the graph of $y = x^2$ along with a shift 4 units to the right.

Now Try Exercise 9.

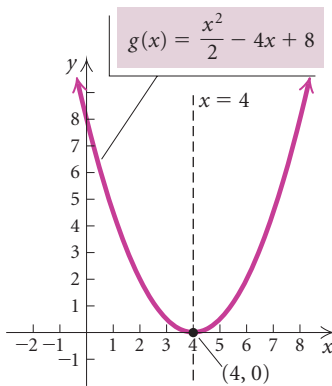

EXAMPLE 3 Find the vertex, the axis of symmetry, and the maximum or minimum value of $f(x) = -2x^2 + 10x - \frac{23}{2}$. Then graph the function.

Solution We have

$$\begin{aligned} f(x) &= -2x^2 + 10x - \frac{23}{2} \\ &= -2(x^2 - 5x) - \frac{23}{2} \\ &= -2\left(x^2 - 5x + \frac{25}{4} - \frac{25}{4}\right) - \frac{23}{2} \\ &= -2\left(x^2 - 5x + \frac{25}{4}\right) - 2\left(-\frac{25}{4}\right) - \frac{23}{2} \\ &= -2\left(x^2 - 5x + \frac{25}{4}\right) + \frac{25}{2} - \frac{23}{2} \\ &= -2\left(x - \frac{5}{2}\right)^2 + 1. \end{aligned}$$

Factoring -2 out of the first two terms
Completing the square inside the parentheses
Using the distributive law to remove $-\frac{25}{4}$ from within the parentheses

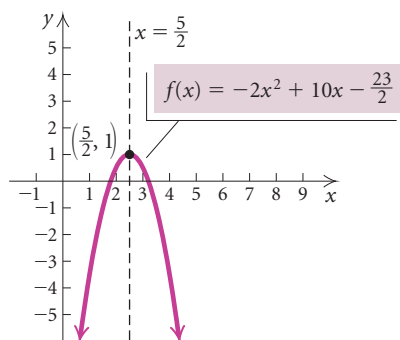

This form of the function yields the following:

Vertex: $\left(\frac{5}{2}, 1\right)$;

Axis of symmetry: $x = \frac{5}{2}$;

Maximum value of the function: 1.

The graph is found by shifting the graph of $f(x) = x^2$ right $\frac{5}{2}$ units, reflecting it across the x -axis, stretching it vertically, and shifting it up 1 unit.

Now Try Exercise 13.

In many situations, we want to use a formula to find the coordinates of the vertex directly from the equation $f(x) = ax^2 + bx + c$. One way to develop such a formula is to observe that the x -coordinate of the vertex is centered between the x -intercepts, or zeros, of the function. By averaging the two solutions of $ax^2 + bx + c = 0$, we find a formula for the x -coordinate of the vertex:

$$\begin{aligned} x\text{-coordinate of vertex} &= \frac{\frac{-b - \sqrt{b^2 - 4ac}}{2a} + \frac{-b + \sqrt{b^2 - 4ac}}{2a}}{2} \\ &= \frac{-2b}{2} = -\frac{b}{a} \\ &= -\frac{b}{a} \cdot \frac{1}{2} = -\frac{b}{2a}. \end{aligned}$$

We use this value of x to find the y -coordinate of the vertex, $f\left(-\frac{b}{2a}\right)$.

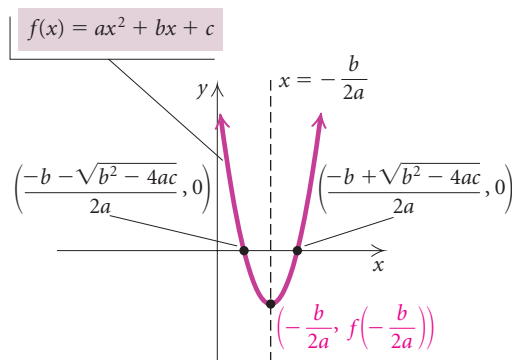

The Vertex of a Parabola

The **vertex** of the graph of $f(x) = ax^2 + bx + c$ is

$$\left(-\frac{b}{2a}, f\left(-\frac{b}{2a}\right)\right).$$

We calculate the x -coordinate.

We substitute to find the y -coordinate.

TECHNOLOGY CONNECTION

We can use a graphing calculator to do Example 4. Once we have graphed $y = -x^2 + 14x - 47$, we see that the graph opens down and thus has a maximum value. We can use the MAXIMUM feature to find the coordinates of the vertex. Using these coordinates, we can then find the maximum value and the range of the function along with the intervals on which the function is increasing or decreasing.

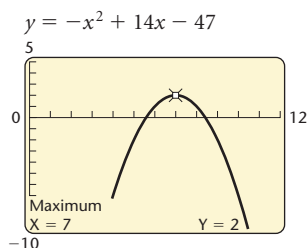

EXAMPLE 4 For the function $f(x) = -x^2 + 14x - 47$:

- Find the vertex.
- Determine whether there is a maximum or minimum value and find that value.
- Find the range.
- On what intervals is the function increasing? decreasing?

Solution There is no need to graph the function.

- a) The x -coordinate of the vertex is

$$-\frac{b}{2a} = -\frac{14}{2(-1)} = -\frac{14}{-2} = 7.$$

Since

$$f(7) = -7^2 + 14 \cdot 7 - 47 = -49 + 98 - 47 = 2,$$

the vertex is $(7, 2)$.

- Since a is negative ($a = -1$), the graph opens down so the second coordinate of the vertex, 2, is the maximum value of the function.
- The range is $(-\infty, 2]$.
- Since the graph opens down, function values increase as we approach the vertex from the left and decrease as we move to the right from the vertex. Thus the function is increasing on the interval $(-\infty, 7)$ and decreasing on $(7, \infty)$.

Now Try Exercise 31.

► Applications

Many real-world situations involve finding the maximum or minimum value of a quadratic function.

EXAMPLE 5 *Maximizing Area.* A landscaper has enough bricks to enclose a rectangular flower box below the picture window of the Jacobsen's house with 12 ft of brick wall. If the house forms one side of the rectangle, what is the maximum area that the landscaper can enclose? What dimensions of the flower box will yield this area?

Solution We will use the five-step problem-solving strategy.

- Familiarize.** We first make a drawing of the situation, using w to represent the width of the flower box, in feet. Then $(12 - 2w)$ feet of brick is available for the length. Suppose the flower box were 1 ft wide. Then its length would be $12 - 2 \cdot 1 = 10$ ft, and its area would be $(10 \text{ ft})(1 \text{ ft}) = 10 \text{ ft}^2$. If the flower box were 2 ft wide, its length would be $12 - 2 \cdot 2 = 8$ ft, and its area would be $(8 \text{ ft})(2 \text{ ft}) = 16 \text{ ft}^2$. This is larger than the first area we found, but we do not know if it is the maximum

PROBLEM-SOLVING STRATEGY

REVIEW SECTION 1.5.

possible area. To find the maximum area, we will find a function that represents the area and then determine its maximum value.



2. **Translate.** We write a function for the area of the flower box. We have

$$\begin{aligned} A(w) &= (12 - 2w)w & A = lw; l = 12 - 2w \\ &= -2w^2 + 12w, \end{aligned}$$

where $A(w)$ is the area of the flower box, in square feet, as a function of the width w .

3. **Carry out.** To solve this problem, we need to determine the maximum value of $A(w)$ and find the dimensions for which that maximum occurs. Since A is a quadratic function and w^2 has a negative coefficient, we know that the function has a maximum value that occurs at the vertex of the graph of the function. The first coordinate of the vertex, $(w, A(w))$, is

$$w = -\frac{b}{2a} = -\frac{12}{2(-2)} = -\frac{12}{-4} = 3.$$

Thus, if $w = 3$ ft, then the length $l = 12 - 2 \cdot 3 = 6$ ft, and the area is $(6 \text{ ft})(3 \text{ ft}) = 18 \text{ ft}^2$.

4. **Check.** As a partial check, we note that $18 \text{ ft}^2 > 16 \text{ ft}^2$, the larger of the two areas we found in the *Familiarize* step. We could also complete the square to write the function in the form $A(w) = a(w - h)^2 + k$, and then use this form of the function to determine the coordinates of the vertex. We get

$$A(w) = -2(w - 3)^2 + 18.$$

This confirms that the vertex is $(3, 18)$, so the answer checks.

5. **State.** The maximum possible area is 18 ft^2 when the flower box is 3 ft wide and 6 ft long.

 **Now Try Exercise 45.**

EXAMPLE 6 *Height of a Rocket.* A model rocket is launched with an initial velocity of 100 ft/sec from the top of a hill that is 20 ft high. Its height, in feet, t seconds after it has been launched is given by the function $s(t) = -16t^2 + 100t + 20$. Determine the time at which the rocket reaches its maximum height and find the maximum height.

Solution

- 1., 2. **Familiarize and Translate.** We are given the function in the statement of the problem: $s(t) = -16t^2 + 100t + 20$.

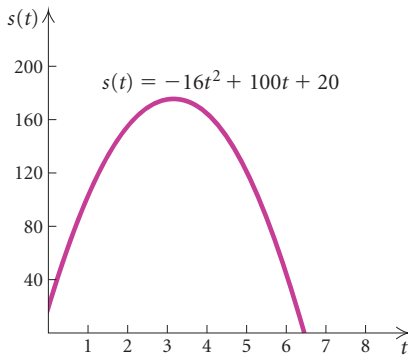

3. Carry out. We need to find the maximum value of the function and the value of t for which it occurs. Since $s(t)$ is a quadratic function and t^2 has a negative coefficient, we know that the maximum value of the function occurs at the vertex of the graph of the function. The first coordinate of the vertex gives the time t at which the rocket reaches its maximum height. It is

$$t = -\frac{b}{2a} = -\frac{100}{2(-16)} = -\frac{100}{-32} = 3.125.$$

The second coordinate of the vertex gives the maximum height of the rocket. We substitute in the function to find it:

$$s(3.125) = -16(3.125)^2 + 100(3.125) + 20 = 176.25.$$

4. Check. As a check, we can complete the square to write the function in the form $s(t) = a(t - h)^2 + k$ and determine the coordinates of the vertex from this form of the function. We get

$$s(t) = -16(t - 3.125)^2 + 176.25.$$

This confirms that the vertex is $(3.125, 176.25)$, so the answer checks.

5. State. The rocket reaches a maximum height of 176.25 ft. This occurs 3.125 sec after it has been launched.

➔ Now Try Exercise 41.

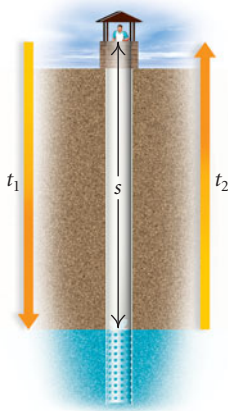

EXAMPLE 7 Finding the Depth of a Well. Two seconds after a chlorine tablet has been dropped into a well, a splash is heard. The speed of sound is 1100 ft/sec. How far is the top of the well from the water?

Solution

1. Familiarize. We first make a drawing and label it with known and unknown information. We let s = the depth of the well, in feet, t_1 = the time, in seconds, that it takes for the tablet to hit the water, and t_2 = the time, in seconds, that it takes for the sound to reach the top of the well. This gives us the equation

$$t_1 + t_2 = 2. \quad (1)$$

2. Translate. Can we find any relationship between the two times and the distance s ? Often in problem solving you may need to look up related formulas in a physics book, another mathematics book, or on the Internet. We find that the formula

$$s = 16t^2$$

gives the distance, in feet, that a dropped object falls in t seconds. The time t_1 that it takes the tablet to hit the water can be found as follows:

$$s = 16t_1^2, \quad \text{or} \quad \frac{s}{16} = t_1^2, \quad \text{so} \quad t_1 = \frac{\sqrt{s}}{4}. \quad \text{Taking the positive square root} \quad (2)$$

To find an expression for t_2 , the time it takes the sound to travel to the top of the well, recall that *Distance = Rate · Time*. Thus,

$$s = 1100t_2, \quad \text{or} \quad t_2 = \frac{s}{1100}. \quad (3)$$

We now have expressions for t_1 and t_2 , both in terms of s . Substituting into equation (1), we obtain

$$t_1 + t_2 = 2, \quad \text{or} \quad \frac{\sqrt{s}}{4} + \frac{s}{1100} = 2. \quad (4)$$



3. Carry out. We solve equation (4) for s . Multiplying by 1100, we get

$$275\sqrt{s} + s = 2200, \quad \text{or} \quad s + 275\sqrt{s} - 2200 = 0.$$

This equation is reducible to quadratic with $u = \sqrt{s}$. Substituting, we get

$$u^2 + 275u - 2200 = 0.$$

Using the quadratic formula, we can solve for u :

$$\begin{aligned} u &= \frac{-b \pm \sqrt{b^2 - 4ac}}{2a} \\ &= \frac{-275 \pm \sqrt{275^2 - 4 \cdot 1 \cdot (-2200)}}{2 \cdot 1} \\ &= \frac{-275 + \sqrt{84,425}}{2} \end{aligned}$$

We want only the positive solution.

$$\approx 7.78.$$

Since $u \approx 7.78$, we have

$$\sqrt{s} \approx 7.78$$

$$s \approx 60.5. \quad \text{Squaring both sides}$$

4. Check. To check, we can substitute 60.5 for s in equation (4) and see that $t_1 + t_2 \approx 2$. We leave the computation to the student.

5. State. The top of the well is about 60.5 ft above the water.

Now Try Exercise 55.

TECHNOLOGY CONNECTION

We can solve the equation in Example 7 graphically using the Intersect method. It will probably require some trial and error to determine an appropriate window.

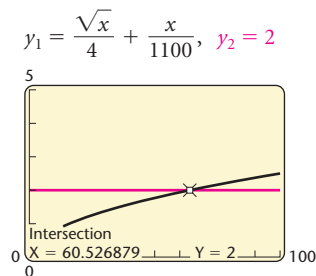

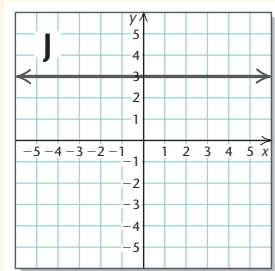
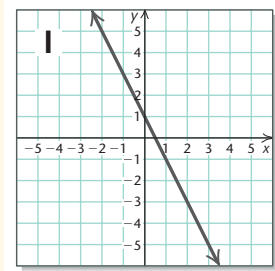
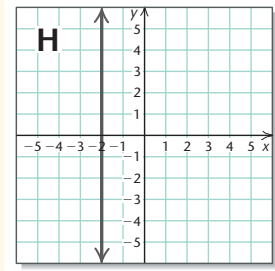
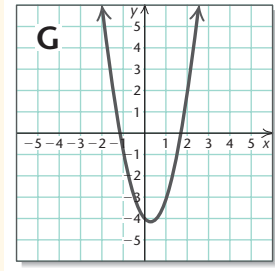
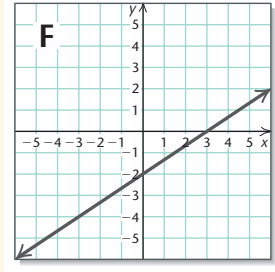
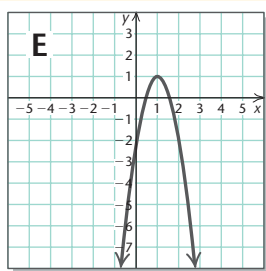
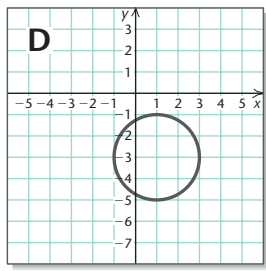
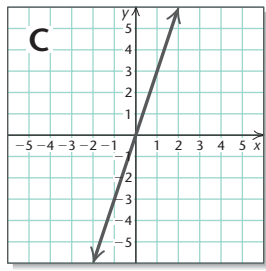
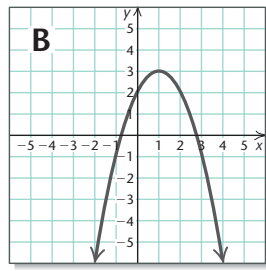
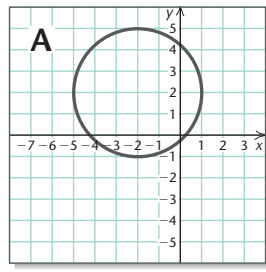

Visualizing the Graph

Match the equation with its graph.

1. $y = 3x$
2. $y = -(x - 1)^2 + 3$
3. $(x + 2)^2 + (y - 2)^2 = 9$
4. $y = 3$
5. $2x - 3y = 6$
6. $(x - 1)^2 + (y + 3)^2 = 4$
7. $y = -2x + 1$
8. $y = 2x^2 - x - 4$
9. $x = -2$
10. $y = -3x^2 + 6x - 2$

Answers on page A-17

3.3

Exercise Set

In Exercises 1 and 2, use the given graph to find each of the following: (a) the vertex; (b) the axis of symmetry; and (c) the maximum or minimum value of the function.

1.

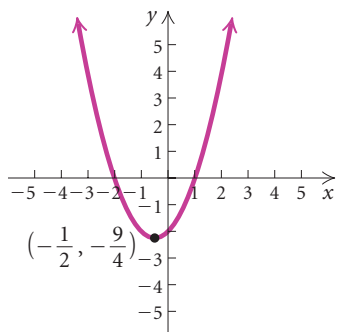

2.

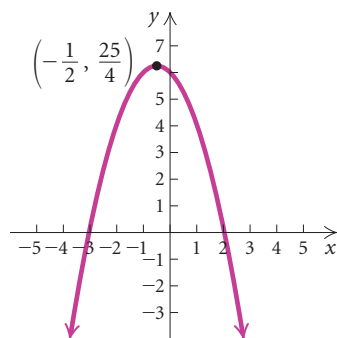

In Exercises 3–16, (a) find the vertex; (b) find the axis of symmetry; (c) determine whether there is a maximum or minimum value, and find that value; and (d) graph the function.

3. $f(x) = x^2 - 8x + 12$

4. $g(x) = x^2 + 7x - 8$

5. $f(x) = x^2 - 7x + 12$

6. $g(x) = x^2 - 5x + 6$

7. $f(x) = x^2 + 4x + 5$

8. $f(x) = x^2 + 2x + 6$

9. $g(x) = \frac{x^2}{2} + 4x + 6$

10. $g(x) = \frac{x^2}{3} - 2x + 1$

11. $g(x) = 2x^2 + 6x + 8$

12. $f(x) = 2x^2 - 10x + 14$

13. $f(x) = -x^2 - 6x + 3$

14. $f(x) = -x^2 - 8x + 5$

15. $g(x) = -2x^2 + 2x + 1$

16. $f(x) = -3x^2 - 3x + 1$

In Exercises 17–24, match the equation with one of the graphs (a)–(h), which follow.

a)

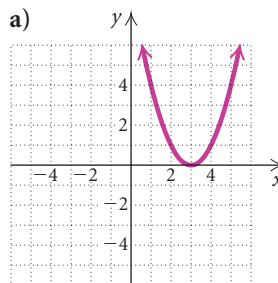

b)

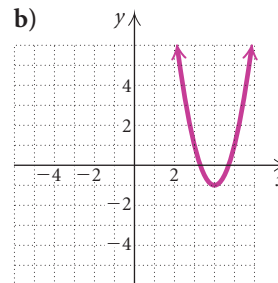

c)

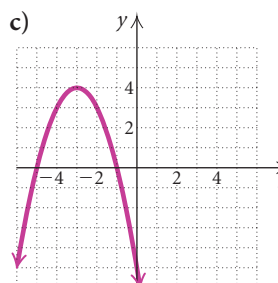

d)

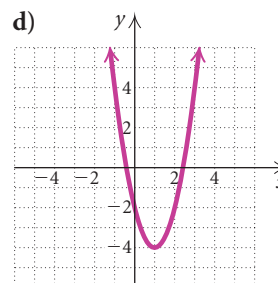

e)

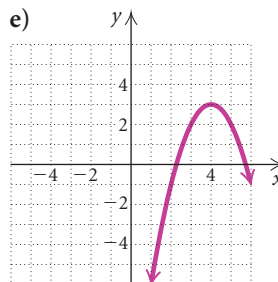

f)

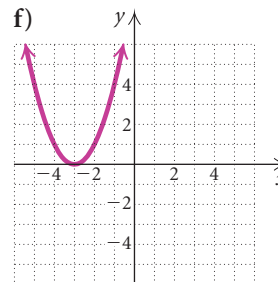

g)

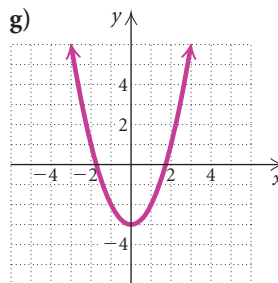

h)

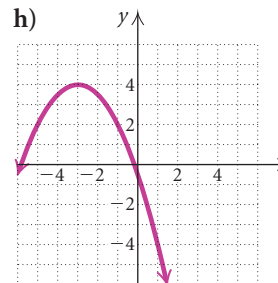

17. $y = (x + 3)^2$

18. $y = -(x - 4)^2 + 3$

19. $y = 2(x - 4)^2 - 1$

20. $y = x^2 - 3$

21. $y = -\frac{1}{2}(x + 3)^2 + 4$

22. $y = (x - 3)^2$

23. $y = -(x + 3)^2 + 4$

24. $y = 2(x - 1)^2 - 4$

Determine whether the statement is true or false.

25. The function $f(x) = -3x^2 + 2x + 5$ has a maximum value.
26. The vertex of the graph of $f(x) = ax^2 + bx + c$ is $-\frac{b}{2a}$.
27. The graph of $h(x) = (x + 2)^2$ can be obtained by translating the graph of $h(x) = x^2$ right 2 units.
28. The vertex of the graph of the function $g(x) = 2(x - 4)^2 - 1$ is $(-4, -1)$.
29. The axis of symmetry of the function $f(x) = -(x + 2)^2 - 4$ is $x = -2$.
30. The minimum value of the function $f(x) = 3(x - 1)^2 + 5$ is 5.

In Exercises 31–40:

- a) Find the vertex.
- b) Determine whether there is a maximum or minimum value, and find that value.
- c) Find the range.
- d) Find the intervals on which the function is increasing and the intervals on which the function is decreasing.

31. $f(x) = x^2 - 6x + 5$
32. $f(x) = x^2 + 4x - 5$
33. $f(x) = 2x^2 + 4x - 16$
34. $f(x) = \frac{1}{2}x^2 - 3x + \frac{5}{2}$
35. $f(x) = -\frac{1}{2}x^2 + 5x - 8$
36. $f(x) = -2x^2 - 24x - 64$
37. $f(x) = 3x^2 + 6x + 5$
38. $f(x) = -3x^2 + 24x - 49$
39. $g(x) = -4x^2 - 12x + 9$
40. $g(x) = 2x^2 - 6x + 5$

41. **Height of a Ball.** A ball is thrown directly upward from a height of 6 ft with an initial velocity of 20 ft/sec. The function $s(t) = -16t^2 + 20t + 6$ gives the height of the ball, in feet, t seconds after it has been thrown. Determine the time at which the ball reaches its maximum height and find the maximum height.
42. **Height of a Projectile.** A stone is thrown directly upward from a height of 30 ft with an initial velocity of 60 ft/sec. The height of the stone, in feet, t seconds after it has been thrown is given by the function $s(t) = -16t^2 + 60t + 30$. Determine the

time at which the stone reaches its maximum height and find the maximum height.

43. **Height of a Rocket.** A model rocket is launched with an initial velocity of 120 ft/sec from a height of 80 ft. The height of the rocket, in feet, t seconds after it has been launched is given by the function $s(t) = -16t^2 + 120t + 80$. Determine the time at which the rocket reaches its maximum height and find the maximum height.
44. **Height of a Rocket.** A model rocket is launched with an initial velocity of 150 ft/sec from a height of 40 ft. The function $s(t) = -16t^2 + 150t + 40$ gives the height of the rocket, in feet, t seconds after it has been launched. Determine the time at which the rocket reaches its maximum height and find the maximum height.
45. **Maximizing Volume.** Mendoza Manufacturing plans to produce a one-compartment vertical file by bending the long side of a 10-in. by 18-in. sheet of plastic along two lines to form a \sqcup -shape. How tall should the file be in order to maximize the volume that it can hold?

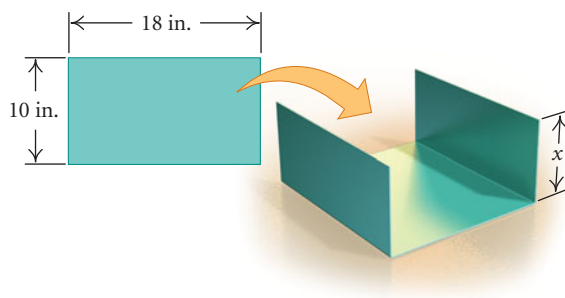

46. **Maximizing Area.** A fourth-grade class decides to enclose a rectangular garden, using the side of the school as one side of the rectangle. What is the maximum area that the class can enclose with 32 ft of fence? What should the dimensions of the garden be in order to yield this area?



47. **Maximizing Area.** The sum of the base and the height of a triangle is 20 cm. Find the dimensions for which the area is a maximum.
48. **Maximizing Area.** The sum of the base and the height of a parallelogram is 69 cm. Find the dimensions for which the area is a maximum.
49. **Minimizing Cost.** Classic Furniture Concepts has determined that when x hundred wooden chairs are built, the average cost per chair is given by

$$C(x) = 0.1x^2 - 0.7x + 1.625,$$

where $C(x)$ is in hundreds of dollars. How many chairs should be built in order to minimize the average cost per chair?



Maximizing Profit. In business, profit is the difference between revenue and cost; that is,

$$\text{Total profit} = \text{Total revenue} - \text{Total cost},$$

$$P(x) = R(x) - C(x),$$

where x is the number of units sold. Find the maximum profit and the number of units that must be sold in order to yield the maximum profit for each of the following.

50. $R(x) = 5x$, $C(x) = 0.001x^2 + 1.2x + 60$
51. $R(x) = 50x - 0.5x^2$, $C(x) = 10x + 3$
52. $R(x) = 20x - 0.1x^2$, $C(x) = 4x + 2$

53. **Maximizing Area.** A rancher needs to enclose two adjacent rectangular corrals, one for cattle and one for sheep. If a river forms one side of the corrals and 240 yd of fencing is available, what is the largest total area that can be enclosed?



54. **Norman Window.** A Norman window is a rectangle with a semicircle on top. Sky Blue Windows is designing a Norman window that will require 24 ft of trim on the outer edges. What dimensions will allow the maximum amount of light to enter a house?

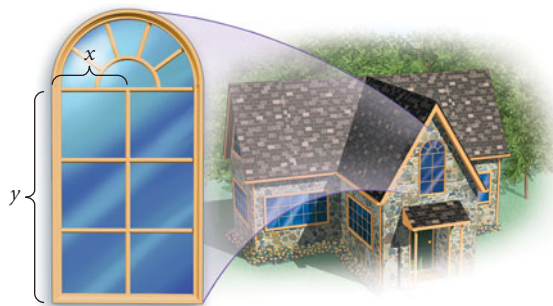

55. **Finding the Height of an Elevator Shaft.** Jenelle drops a screwdriver from the top of an elevator shaft. Exactly 5 sec later, she hears the sound of the screwdriver hitting the bottom of the shaft. How tall is the elevator shaft? (*Hint:* See Example 7.)
56. **Finding the Height of a Cliff.** A water balloon is dropped from a cliff. Exactly 3 sec later, the sound of the balloon hitting the ground reaches the top of the cliff. How high is the cliff? (*Hint:* See Example 7.)

Skill Maintenance

For each function f , construct and simplify the difference quotient

$$\frac{f(x+h) - f(x)}{h}$$

57. $f(x) = 3x - 7$

58. $f(x) = 2x^2 - x + 4$

A graph of $y = f(x)$ follows. No formula is given for f . Graph each of the following.

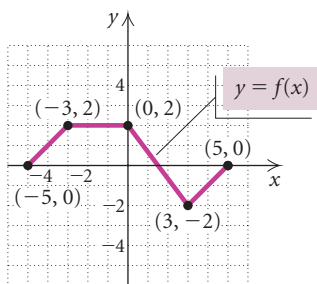

59. $g(x) = -2f(x)$

60. $g(x) = f(2x)$

Synthesis

61. Find c such that

$$f(x) = -0.2x^2 - 3x + c$$

has a maximum value of -225 .62. Find b such that

$$f(x) = -4x^2 + bx + 3$$

has a maximum value of 50 .63. Graph: $f(x) = (|x| - 5)^2 - 3$.64. Find a quadratic function with vertex $(4, -5)$ and containing the point $(-3, 1)$.

65. **Minimizing Area.** A 24-in. piece of string is cut into two pieces. One piece is used to form a circle while the other is used to form a square. How should the string be cut so that the sum of the areas is a minimum?

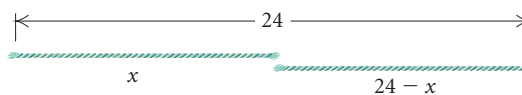

Mid-Chapter Mixed Review

Determine whether the statement is true or false.

- The product of a complex number and its conjugate is a real number. [3.1]
- Every quadratic equation has at least one x -intercept. [3.2]
- If a quadratic equation has two different real-number solutions, then its discriminant is positive. [3.2]
- The vertex of the graph of the function $f(x) = 3(x + 4)^2 + 5$ is $(4, 5)$. [3.3]

Express the number in terms of i . [3.1]

5. $\sqrt{-36}$

7. $-\sqrt{-16}$

6. $\sqrt{-5}$

8. $\sqrt{-32}$

Simplify. Write answers in the form $a + bi$, where a and b are real numbers. [3.1]

9. $(3 - 2i) + (-4 + 3i)$

10. $(-5 + i) - (2 - 4i)$

11. $(2 + 3i)(4 - 5i)$

12. $\frac{3 + i}{-2 + 5i}$

Simplify. [3.1]

13. i^{13}

14. i^{44}

15. $(-i)^5$

16. $(2i)^6$

Solve. [3.2]

17. $x^2 + 3x - 4 = 0$

18. $2x^2 + 6 = -7x$

19. $4x^2 = 24$

20. $x^2 + 100 = 0$

21. Find the zeros of $f(x) = 4x^2 - 8x - 3$ by completing the square. Show your work. [3.2]

In Exercises 22–24, (a) find the discriminant $b^2 - 4ac$, and then determine whether one real-number solution, two different real-number solutions, or two different imaginary-number solutions exist; and (b) solve the equation, finding exact solutions and approximate solutions rounded to three decimal places, where appropriate. [3.2]

22. $x^2 - 3x - 5 = 0$

23. $4x^2 - 12x + 9 = 0$

24. $3x^2 + 2x = -1$

Solve. [3.2]

25. $x^4 + 5x^2 - 6 = 0$

26. $2x - 5\sqrt{x} + 2 = 0$

27. One number is 2 more than another. The product of the numbers is 35. Find the numbers. [3.2]

In Exercises 28 and 29:

a) Find the vertex. [3.3]

b) Find the axis of symmetry. [3.3]

c) Determine whether there is a maximum or minimum value, and find that value. [3.3]

d) Find the range. [3.3]

e) Find the intervals on which the function is increasing or decreasing. [3.3]

f) Graph the function. [3.3]

28. $f(x) = x^2 - 6x + 7$

29. $f(x) = -2x^2 - 4x - 5$

30. The sum of the base and the height of a triangle is 16 in. Find the dimensions for which the area is a maximum. [3.3]

Collaborative Discussion and Writing

31. Is the sum of two imaginary numbers always an imaginary number? Explain your answer. [3.1]

32. The graph of a quadratic function can have 0, 1, or 2 x -intercepts. How can you predict the number of x -intercepts without drawing the graph or (completely) solving an equation? [3.2]

33. Discuss two ways in which we used completing the square in this chapter. [3.2], [3.3]

34. Suppose that the graph of $f(x) = ax^2 + bx + c$ has x -intercepts $(x_1, 0)$ and $(x_2, 0)$. What are the x -intercepts of $g(x) = -ax^2 - bx - c$? Explain. [3.3]

Solving Rational Equations and Radical Equations

3.4

- ▶ Solve rational equations.
- ▶ Solve radical equations.

▶ Rational Equations

Equations containing rational expressions are called **rational equations**. Solving such equations involves multiplying both sides by the least common denominator (LCD) to *clear the equation of fractions*.

EXAMPLE 1 Solve: $\frac{x-8}{3} + \frac{x-3}{2} = 0$.

Algebraic Solution

We have

$$\frac{x-8}{3} + \frac{x-3}{2} = 0$$

$$6\left(\frac{x-8}{3} + \frac{x-3}{2}\right) = 6 \cdot 0$$

The LCD is $3 \cdot 2$, or 6.

Multiplying by the LCD on both sides to clear fractions

$$6 \cdot \frac{x-8}{3} + 6 \cdot \frac{x-3}{2} = 0$$

$$2(x-8) + 3(x-3) = 0$$

$$2x - 16 + 3x - 9 = 0$$

$$5x - 25 = 0$$

$$5x = 25$$

$$x = 5.$$

The possible solution is 5.

Check:

$$\frac{x-8}{3} + \frac{x-3}{2} = 0$$

$$\frac{5-8}{3} + \frac{5-3}{2} \stackrel{?}{=} 0$$

$$\frac{-3}{3} + \frac{2}{2}$$

$$-1 + 1$$

$$0 = 0 \quad \text{TRUE}$$

The solution is 5.

Visualizing the Solution

The solution of the given equation is the zero of the function

$$f(x) = \frac{x-8}{3} + \frac{x-3}{2}.$$

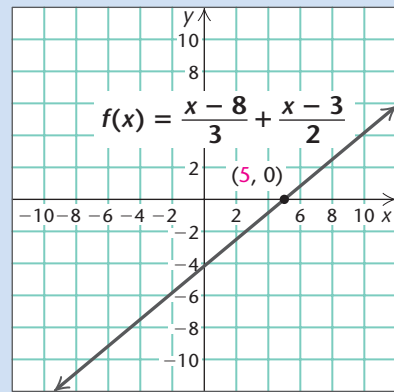

The zero of the function is 5. Thus the solution of the equation is 5.

➔ Now Try Exercise 3.

TECHNOLOGY CONNECTION

We can use the Zero method to solve the equation in Example 1. We find the zero of the function

$$f(x) = \frac{x - 8}{3} + \frac{x - 3}{2}.$$

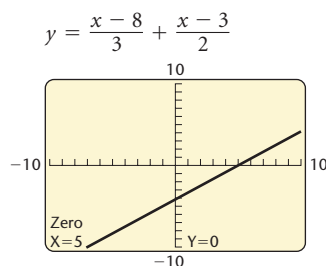

The zero of the function is 5. Thus the solution of the equation is 5.

CAUTION! Clearing fractions is a valid procedure when solving rational equations but not when adding, subtracting, multiplying, or dividing rational expressions. A rational expression may have operation signs but it will have no equals sign. A rational equation *always* has an equals sign. For example, $\frac{x - 8}{3} + \frac{x - 3}{2}$ is a rational expression

but $\frac{x - 8}{3} + \frac{x - 3}{2} = 0$ is a rational equation.

To *simplify* the rational expression $\frac{x - 8}{3} + \frac{x - 3}{2}$, we first find the LCD and write each fraction with that denominator. The final result is usually a rational expression.

To *solve* the rational equation $\frac{x - 8}{3} + \frac{x - 3}{2} = 0$, we first multiply both sides by the LCD to clear fractions. The final result is one or more numbers. As we will see in Example 2, these numbers must be checked in the original equation.

When we use the multiplication principle to multiply (or divide) on both sides of an equation by an expression with a variable, we might not obtain an equivalent equation. We must check the possible solutions obtained in this manner by substituting them in the original equation. The next example illustrates this.

TECHNOLOGY CONNECTION

We can use a table on a graphing calculator to check the possible solutions in Example 2. We enter

$$y_1 = \frac{x^2}{x-3} \text{ and } y_2 = \frac{9}{x-3}.$$

$$y_1 = \frac{x^2}{x-3}, \quad y_2 = \frac{9}{x-3}$$

X	Y1	Y2
-3	-1.5	-1.5
3	ERROR	ERROR
X =		

When $x = -3$, we see that $y_1 = -1.5 = y_2$, so -3 is a solution. When $x = 3$, we get ERROR messages. This indicates that 3 is not in the domain of y_1 or y_2 and, thus, is not a solution.

TECHNOLOGY CONNECTION

We can use a table on a graphing calculator to check the possible solution in Example 3.

Enter

$$y_1 = \frac{2}{3x+6} + \frac{1}{x^2-4}$$

and

$$y_2 = \frac{4}{x-2}.$$

$$y_1 = \frac{2}{3x+6} + \frac{1}{x^2-4}, \quad y_2 = \frac{4}{x-2}$$

X	Y1	Y2
-2.5	-.8889	-.8889
X =		

We see that $y_1 = y_2$ when $x = -\frac{5}{2}$, or -2.5 , so $-\frac{5}{2}$ is the solution.

EXAMPLE 2 Solve: $\frac{x^2}{x-3} = \frac{9}{x-3}$.

Solution The LCD is $x - 3$.

$$(x-3) \cdot \frac{x^2}{x-3} = (x-3) \cdot \frac{9}{x-3}$$

$$x^2 = 9$$

$$x = -3 \text{ or } x = 3 \quad \text{Using the principle of square roots}$$

The possible solutions are -3 and 3 . We check.

Check: For -3 :

$$\frac{x^2}{x-3} = \frac{9}{x-3}$$

$$\frac{(-3)^2}{-3-3} \quad ? \quad \frac{9}{-3-3}$$

$$\frac{9}{-6} \quad ? \quad \frac{9}{-6} \quad \text{TRUE}$$

For 3 :

$$\frac{x^2}{x-3} = \frac{9}{x-3}$$

$$\frac{(3)^2}{3-3} \quad ? \quad \frac{9}{3-3}$$

$$\frac{9}{0} \quad ? \quad \frac{9}{0} \quad \text{NOT DEFINED}$$

The number -3 checks, so it is a solution. Since division by 0 is not defined, 3 is not a solution. Note that 3 is not in the domain of either $x^2/(x-3)$ or $9/(x-3)$.

 **Now Try Exercise 23.**

EXAMPLE 3 Solve: $\frac{2}{3x+6} + \frac{1}{x^2-4} = \frac{4}{x-2}$.

Solution We first factor the denominators in order to determine the LCD:

$$\frac{2}{3(x+2)} + \frac{1}{(x+2)(x-2)} = \frac{4}{x-2} \quad \text{The LCD is } 3(x+2)(x-2).$$

$$3(x+2)(x-2) \left(\frac{2}{3(x+2)} + \frac{1}{(x+2)(x-2)} \right) = 3(x+2)(x-2) \cdot \frac{4}{x-2}$$

Multiplying by the LCD to clear fractions

$$2(x-2) + 3 = 3 \cdot 4(x+2)$$

$$2x - 4 + 3 = 12x + 24$$

$$2x - 1 = 12x + 24$$

$$-10x = 25$$

$$x = -\frac{5}{2}$$

The possible solution is $-\frac{5}{2}$. This number checks. It is the solution.

 **Now Try Exercise 19.**

► Radical Equations

A **radical equation** is an equation in which variables appear in one or more radicands. For example,

$$\sqrt{2x-5} - \sqrt{x-3} = 1$$

is a radical equation. The following principle is used to solve such equations.

The Principle of Powers

For any positive integer n :

If $a = b$ is true, then $a^n = b^n$ is true.

EXAMPLE 4 Solve: $\sqrt{3x + 1} = 4$.

Solution We have

$$\sqrt{3x + 1} = 4$$

$$(\sqrt{3x + 1})^2 = 4^2$$

Using the principle of powers;
squaring both sides

$$3x + 1 = 16$$

$$3x = 15$$

$$x = 5.$$

Check:

$$\sqrt{3x + 1} = 4$$

$$\sqrt{3 \cdot 5 + 1} \stackrel{?}{=} 4$$

$$\sqrt{15 + 1}$$

$$\sqrt{16}$$

$$4 = 4 \quad \text{TRUE}$$

The solution is 5.

 **Now Try Exercise 29.**

In Example 4, the radical was isolated on one side of the equation. If this had not been the case, our first step would have been to isolate the radical. We do so in the next example.

TECHNOLOGY CONNECTION

We can use the Intersect method to solve the equation in Example 4. We graph $y_1 = \sqrt{3x + 1}$ and $y_2 = 4$ and then use the INTERSECT feature. We see that the solution is 5.

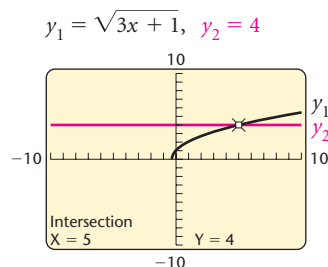

EXAMPLE 5 Solve: $5 + \sqrt{x + 7} = x$.**Algebraic Solution**

We first isolate the radical and then use the principle of powers.

$$5 + \sqrt{x + 7} = x$$

$$\sqrt{x + 7} = x - 5$$

Subtracting 5 on both sides

$$(\sqrt{x + 7})^2 = (x - 5)^2$$

Using the principle of powers; squaring both sides

$$x + 7 = x^2 - 10x + 25$$

$$0 = x^2 - 11x + 18$$

Subtracting x and 7

$$0 = (x - 9)(x - 2)$$

Factoring

$$x - 9 = 0 \quad \text{or} \quad x - 2 = 0$$

$$x = 9 \quad \text{or} \quad x = 2$$

The possible solutions are 9 and 2.

Check: For 9:

$$5 + \sqrt{x + 7} = x$$

$$5 + \sqrt{9 + 7} \stackrel{?}{=} 9$$

$$5 + \sqrt{16}$$

$$5 + 4$$

$$9 \quad | \quad 9 \quad \text{TRUE}$$

For 2:

$$5 + \sqrt{x + 7} = x$$

$$5 + \sqrt{2 + 7} \stackrel{?}{=} 2$$

$$5 + \sqrt{9}$$

$$5 + 3$$

$$8 \quad | \quad 2 \quad \text{FALSE}$$

Since 9 checks but 2 does not, the only solution is 9.

Visualizing the Solution

When we graph $y = 5 + \sqrt{x + 7}$ and $y = x$, we find that the first coordinate of the point of intersection of the graphs is 9. Thus the solution of $5 + \sqrt{x + 7} = x$ is 9.

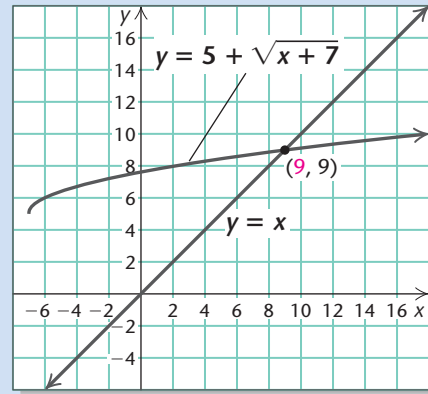

Note that the graphs show that the equation has only one solution.

➔ Now Try Exercise 53.

TECHNOLOGY CONNECTION

We can use a graphing calculator to solve the equation in Example 5. We can graph $y_1 = 5 + \sqrt{x + 7}$ and $y_2 = x$. Using the INTERSECT feature, we see in the window on the left below that the solution is 9.

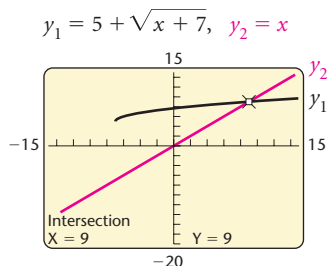

We can also use the ZERO feature to get this result, as shown in the window on the right. To do so, we first write the equivalent equation $5 + \sqrt{x + 7} - x = 0$. The zero of the function $f(x) = 5 + \sqrt{x + 7} - x$ is 9, so the solution of the original equation is 9.

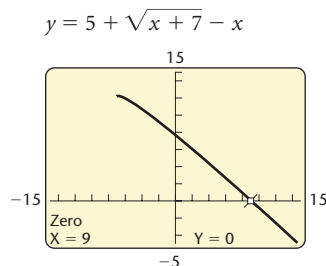

STUDY TIP

Consider forming a study group with some of your fellow students. Exchange e-mail addresses, telephone numbers, and schedules so you can coordinate study time for homework and tests.

When we raise both sides of an equation to an even power, the resulting equation can have solutions that the original equation does not. This is because the converse of the principle of powers is not necessarily true. That is, if $a^n = b^n$ is true, we do not know that $a = b$ is true. For example, $(-2)^2 = 2^2$, but $-2 \neq 2$. Thus, as we saw in Example 5, it is necessary to check the possible solutions in the original equation when the principle of powers is used to raise both sides of an equation to an even power.

When a radical equation has two radical terms on one side, we isolate one of them and then use the principle of powers. If, after doing so, a radical term remains, we repeat these steps.

EXAMPLE 6 Solve: $\sqrt{x - 3} + \sqrt{x + 5} = 4$.

Solution We have

$$\begin{aligned}\sqrt{x - 3} &= 4 - \sqrt{x + 5} \\ (\sqrt{x - 3})^2 &= (4 - \sqrt{x + 5})^2\end{aligned}$$

$$x - 3 = 16 - 8\sqrt{x + 5} + (x + 5)$$

$$x - 3 = 21 - 8\sqrt{x + 5} + x$$

$$-24 = -8\sqrt{x + 5}$$

$$3 = \sqrt{x + 5}$$

$$3^2 = (\sqrt{x + 5})^2$$

$$9 = x + 5$$

$$4 = x.$$

The number 4 checks. It is the solution.

Isolating one radical

Using the principle of powers; squaring both sides

Combining like terms

Isolating the remaining radical; subtracting x and 21 on both sides

Dividing by -8 on both sides

Using the principle of powers; squaring both sides

Subtracting 5 on both sides

Now Try Exercise 63.

TECHNOLOGY CONNECTION

We check the possible solution in Example 6 on a graphing calculator.

$$y_1 = \sqrt{x - 3} + \sqrt{x + 5}, y_2 = 4$$

X	Y1	Y2
4	4	4
X =		

Since $y_1 = y_2$ when $x = 4$, the number 4 checks. It is the solution.

3.4 Exercise Set

Solve.

1. $\frac{1}{4} + \frac{1}{5} = \frac{1}{t}$
2. $\frac{1}{3} - \frac{5}{6} = \frac{1}{x}$
3. $\frac{x+2}{4} - \frac{x-1}{5} = 15$
4. $\frac{t+1}{3} - \frac{t-1}{2} = 1$
5. $\frac{1}{2} + \frac{2}{x} = \frac{1}{3} + \frac{3}{x}$
6. $\frac{1}{t} + \frac{1}{2t} + \frac{1}{3t} = 5$
7. $\frac{5}{3x+2} = \frac{3}{2x}$
8. $\frac{2}{x-1} = \frac{3}{x+2}$
9. $x + \frac{6}{x} = 5$
10. $x - \frac{12}{x} = 1$
11. $\frac{6}{y+3} + \frac{2}{y} = \frac{5y-3}{y^2-9}$
12. $\frac{3}{m+2} + \frac{2}{m} = \frac{4m-4}{m^2-4}$
13. $\frac{2x}{x-1} = \frac{5}{x-3}$
14. $\frac{2x}{x+7} = \frac{5}{x+1}$
15. $\frac{2}{x+5} + \frac{1}{x-5} = \frac{16}{x^2-25}$
16. $\frac{2}{x^2-9} + \frac{5}{x-3} = \frac{3}{x+3}$
17. $\frac{3x}{x+2} + \frac{6}{x} = \frac{12}{x^2+2x}$
18. $\frac{3y+5}{y^2+5y} + \frac{y+4}{y+5} = \frac{y+1}{y}$
19. $\frac{1}{5x+20} - \frac{1}{x^2-16} = \frac{3}{x-4}$
20. $\frac{1}{4x+12} - \frac{1}{x^2-9} = \frac{5}{x-3}$
21. $\frac{2}{5x+5} - \frac{3}{x^2-1} = \frac{4}{x-1}$
22. $\frac{1}{3x+6} - \frac{1}{x^2-4} = \frac{3}{x-2}$
23. $\frac{8}{x^2-2x+4} = \frac{x}{x+2} + \frac{24}{x^3+8}$
24. $\frac{18}{x^2-3x+9} - \frac{x}{x+3} = \frac{81}{x^3+27}$
25. $\frac{x}{x-4} - \frac{4}{x+4} = \frac{32}{x^2-16}$
26. $\frac{x}{x-1} - \frac{1}{x+1} = \frac{2}{x^2-1}$
27. $\frac{1}{x-6} - \frac{1}{x} = \frac{6}{x^2-6x}$
28. $\frac{1}{x-15} - \frac{1}{x} = \frac{15}{x^2-15x}$
29. $\sqrt{3x-4} = 1$
30. $\sqrt{4x+1} = 3$
31. $\sqrt{2x-5} = 2$
32. $\sqrt{3x+2} = 6$
33. $\sqrt{7-x} = 2$
34. $\sqrt{5-x} = 1$
35. $\sqrt{1-2x} = 3$
36. $\sqrt{2-7x} = 2$
37. $\sqrt[3]{5x-2} = -3$
38. $\sqrt[3]{2x+1} = -5$
39. $\sqrt[4]{x^2-1} = 1$

40. $\sqrt[5]{3x + 4} = 2$

41. $\sqrt{y - 1} + 4 = 0$

42. $\sqrt{m + 1} - 5 = 8$

43. $\sqrt{b + 3} - 2 = 1$

44. $\sqrt{x - 4} + 1 = 5$

45. $\sqrt{z + 2} + 3 = 4$

46. $\sqrt{y - 5} - 2 = 3$

47. $\sqrt{2x + 1} - 3 = 3$

48. $\sqrt{3x - 1} + 2 = 7$

49. $\sqrt{2 - x} - 4 = 6$

50. $\sqrt{5 - x} + 2 = 8$

51. $\sqrt[3]{6x + 9} + 8 = 5$

52. $\sqrt[5]{2x - 3} - 1 = 1$

53. $\sqrt{x + 4} + 2 = x$

54. $\sqrt{x + 1} + 1 = x$

55. $\sqrt{x - 3} + 5 = x$

56. $\sqrt{x + 3} - 1 = x$

57. $\sqrt{x + 7} = x + 1$

58. $\sqrt{6x + 7} = x + 2$

59. $\sqrt{3x + 3} = x + 1$

60. $\sqrt{2x + 5} = x - 5$

61. $\sqrt{5x + 1} = x - 1$

62. $\sqrt{7x + 4} = x + 2$

63. $\sqrt{x - 3} + \sqrt{x + 2} = 5$

64. $\sqrt{x} - \sqrt{x - 5} = 1$

65. $\sqrt{3x - 5} + \sqrt{2x + 3} + 1 = 0$

66. $\sqrt{2m - 3} = \sqrt{m + 7} - 2$

67. $\sqrt{x} - \sqrt{3x - 3} = 1$

68. $\sqrt{2x + 1} - \sqrt{x} = 1$

69. $\sqrt{2y - 5} - \sqrt{y - 3} = 1$

70. $\sqrt{4p + 5} + \sqrt{p + 5} = 3$

71. $\sqrt{y + 4} - \sqrt{y - 1} = 1$

72. $\sqrt{y + 7} + \sqrt{y + 16} = 9$

73. $\sqrt{x + 5} + \sqrt{x + 2} = 3$

74. $\sqrt{6x + 6} = 5 + \sqrt{21 - 4x}$

75. $x^{1/3} = -2$

76. $t^{1/5} = 2$

77. $t^{1/4} = 3$

78. $m^{1/2} = -7$

Solve.

79. $\frac{P_1 V_1}{T_1} = \frac{P_2 V_2}{T_2}$, for T_1
(A chemistry formula for gases)

80. $\frac{1}{F} = \frac{1}{m} + \frac{1}{p}$, for F
(A formula from optics)

81. $W = \sqrt{\frac{1}{LC}}$, for C
(An electricity formula)

82. $s = \sqrt{\frac{A}{6}}$, for A
(A geometry formula)

83. $\frac{1}{R} = \frac{1}{R_1} + \frac{1}{R_2}$, for R_2
(A formula for resistance)

84. $\frac{1}{t} = \frac{1}{a} + \frac{1}{b}$, for t
(A formula for work rate)

85. $I = \sqrt{\frac{A}{P}} - 1$, for P
(A compound-interest formula)

86. $T = 2\pi\sqrt{\frac{1}{g}}$, for g
(A pendulum formula)

87. $\frac{1}{F} = \frac{1}{m} + \frac{1}{p}$, for p
(A formula from optics)

88. $\frac{V^2}{R^2} = \frac{2g}{R + h}$, for h
(A formula for escape velocity)

Skill Maintenance

Find the zero of the function.

89. $f(x) = 15 - 2x$

90. $f(x) = -3x + 9$

91. **Deadly Distractions.** Drivers who were distracted by such things as text-messaging, talking on cell phones, conversing with passengers, and eating were involved in 5870 highway fatalities in 2008.

This was an increase of about 18% over the number of distracted-driving fatalities in 2004 and is attributed largely to the increased number of drivers who texted in 2008. (Source: NHTSA's National Center for Statistics and Analysis) How many highway fatalities involved distracted driving in 2004?

92. **Big Sites.** Together, the Mall of America in Minnesota and the Disneyland theme park in

California occupy 181 acres of land. The Mall of America occupies 11 acres more than Disneyland. (Sources: Mall of America; Disneyland) How much land does each occupy?

Synthesis

Solve.

93. $(x - 3)^{2/3} = 2$

94. $\frac{x + 3}{x + 2} - \frac{x + 4}{x + 3} = \frac{x + 5}{x + 4} - \frac{x + 6}{x + 5}$

95. $\sqrt{x + 5} + 1 = \frac{6}{\sqrt{x + 5}}$

96. $\sqrt{15 + \sqrt{2x + 80}} = 5$

97. $x^{2/3} = x$

Solving Equations and Inequalities with Absolute Value**3.5**

- ▶ Solve equations with absolute value.
- ▶ Solve inequalities with absolute value.

ABSOLUTE VALUEREVIEW SECTION **R.1****▶ Equations with Absolute Value**

Recall that the absolute value of a number is its distance from 0 on the number line. We use this concept to solve equations with absolute value.

For $a > 0$ and an algebraic expression X :

$$|X| = a \text{ is equivalent to } X = -a \text{ or } X = a.$$

EXAMPLE 1 Solve: $|x| = 5$.**Algebraic Solution**

We have

$$|x| = 5$$

$$x = -5 \text{ or } x = 5.$$

Writing an equivalent statement

The solutions are -5 and 5 .

To check, note that -5 and 5 are both 5 units from 0 on the number line.

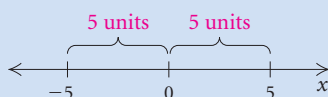
**Visualizing the Solution**

The first coordinates of the points of intersection of the graphs of $y = |x|$ and $y = 5$ are -5 and 5 . These are the solutions of the equation $|x| = 5$.

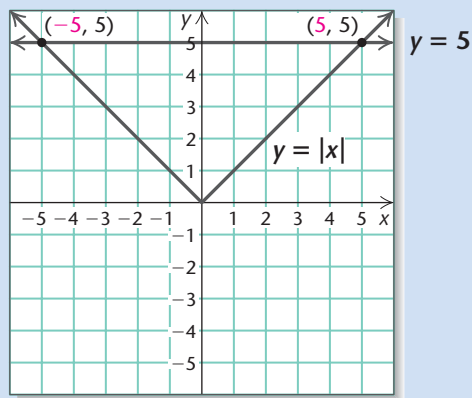

➔ **Now Try Exercise 1.**

EXAMPLE 2 Solve: $|x - 3| - 1 = 4$.

Solution First, we add 1 on both sides to get an expression of the form $|X| = a$:

$$|x - 3| - 1 = 4$$

$$|x - 3| = 5$$

$$x - 3 = -5 \text{ or } x - 3 = 5$$

$$x = -2 \text{ or } x = 8.$$

$|X| = a$ is equivalent to $X = -a$ or $X = a$.
Adding 3

Check: For -2 :

$$\begin{array}{r|l} |x - 3| - 1 = 4 & \\ |-2 - 3| - 1 \stackrel{?}{=} 4 & \\ |-5| - 1 & \\ 5 - 1 & \\ 4 & 4 \text{ TRUE} \end{array}$$

For 8 :

$$\begin{array}{r|l} |x - 3| - 1 = 4 & \\ |8 - 3| - 1 \stackrel{?}{=} 4 & \\ |5| - 1 & \\ 5 - 1 & \\ 4 & 4 \text{ TRUE} \end{array}$$

The solutions are -2 and 8 .

➔ **Now Try Exercise 21.**

When $a = 0$, $|X| = a$ is equivalent to $X = 0$. Note that for $a < 0$, $|X| = a$ has no solution, because the absolute value of an expression is never negative. We can use a graph to illustrate the last statement for a specific value of a . For example, if we let $a = -3$ and graph $y = |x|$ and $y = -3$, we see that the graphs do not intersect, as shown below. Thus the equation $|x| = -3$ has no solution. The solution set is the **empty set**, denoted \emptyset .

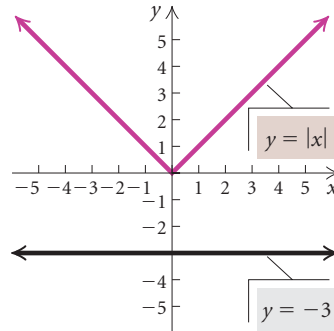

► Inequalities with Absolute Value

Inequalities sometimes contain absolute-value notation. The following properties are used to solve them.

For $a > 0$ and an algebraic expression X :

$$|X| < a \text{ is equivalent to } -a < X < a.$$

$$|X| > a \text{ is equivalent to } X < -a \text{ or } X > a.$$

Similar statements hold for $|X| \leq a$ and $|X| \geq a$.

For example,

$$|x| < 3 \text{ is equivalent to } -3 < x < 3;$$

$$|y| \geq 1 \text{ is equivalent to } y \leq -1 \text{ or } y \geq 1; \text{ and}$$

$$|2x + 3| \leq 4 \text{ is equivalent to } -4 \leq 2x + 3 \leq 4.$$

EXAMPLE 3 Solve and graph the solution set: $|3x + 2| < 5$.

Solution We have

$$|3x + 2| < 5$$

$$-5 < 3x + 2 < 5 \quad \text{Writing an equivalent inequality}$$

$$-7 < 3x < 3 \quad \text{Subtracting 2}$$

$$-\frac{7}{3} < x < 1. \quad \text{Dividing by 3}$$

The solution set is $\{x \mid -\frac{7}{3} < x < 1\}$, or $(-\frac{7}{3}, 1)$. The graph of the solution set is shown below.

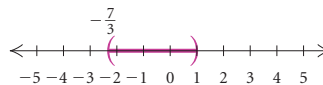

➔ Now Try Exercise 45.

EXAMPLE 4 Solve and graph the solution set: $|5 - 2x| \geq 1$.

Solution We have

$$|5 - 2x| \geq 1$$

$$5 - 2x \leq -1 \quad \text{or} \quad 5 - 2x \geq 1$$

Writing an equivalent inequality

$$-2x \leq -6 \quad \text{or} \quad -2x \geq -4$$

Subtracting 5

$$x \geq 3 \quad \text{or} \quad x \leq 2.$$

Dividing by -2 and reversing the inequality signs

The solution set is $\{x \mid x \leq 2 \text{ or } x \geq 3\}$, or $(-\infty, 2] \cup [3, \infty)$. The graph of the solution set is shown below.

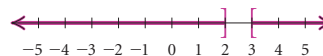

➔ Now Try Exercise 47.

3.5

Exercise Set

Solve.

- | | | | |
|-------------------------------|-------------------------------|---|-------------------------|
| 1. $ x = 7$ | 2. $ x = 4.5$ | 23. $ x + 3 - 2 = 8$ | 24. $ x - 4 + 3 = 9$ |
| 3. $ x = 0$ | 4. $ x = \frac{3}{2}$ | 25. $ 3x + 1 - 4 = -1$ | 26. $ 2x - 1 - 5 = -3$ |
| 5. $ x = \frac{5}{6}$ | 6. $ x = -\frac{3}{5}$ | 27. $ 4x - 3 + 1 = 7$ | 28. $ 5x + 4 + 2 = 5$ |
| 7. $ x = -10.7$ | 8. $ x = 12$ | 29. $12 - x + 6 = 5$ | 30. $9 - x - 2 = 7$ |
| 9. $ 3x = 1$ | 10. $ 5x = 4$ | 31. $7 - 2x - 1 = 6$ | 32. $5 - 4x + 3 = 2$ |
| 11. $ 8x = 24$ | 12. $ 6x = 0$ | <i>Solve and write interval notation for the solution set. Then graph the solution set.</i> | |
| 13. $ x - 1 = 4$ | 14. $ x - 7 = 5$ | 33. $ x < 7$ | 34. $ x \leq 4.5$ |
| 15. $ x + 2 = 6$ | 16. $ x + 5 = 1$ | 35. $ x \leq 2$ | 36. $ x < 3$ |
| 17. $ 3x + 2 = 1$ | 18. $ 7x - 4 = 8$ | 37. $ x \geq 4.5$ | 38. $ x > 7$ |
| 19. $ \frac{1}{2}x - 5 = 17$ | 20. $ \frac{1}{3}x - 4 = 13$ | 39. $ x > 3$ | 40. $ x \geq 2$ |
| 21. $ x - 1 + 3 = 6$ | 22. $ x + 2 - 5 = 9$ | 41. $ 3x < 1$ | 42. $ 5x \leq 4$ |

43. $|2x| \geq 6$
45. $|x + 8| < 9$
47. $|x + 8| \geq 9$
49. $|x - \frac{1}{4}| < \frac{1}{2}$
51. $|2x + 3| \leq 9$
53. $|x - 5| > 0.1$
55. $|6 - 4x| \geq 8$
57. $|x + \frac{2}{3}| \leq \frac{5}{3}$
59. $\left| \frac{2x + 1}{3} \right| > 5$
61. $|2x - 4| < -5$
44. $|4x| > 20$
46. $|x + 6| \leq 10$
48. $|x + 6| > 10$
50. $|x - 0.5| \leq 0.2$
52. $|3x + 4| < 13$
54. $|x - 7| \geq 0.4$
56. $|5 - 2x| > 10$
58. $|x + \frac{3}{4}| < \frac{1}{4}$
60. $\left| \frac{2x - 1}{3} \right| \geq \frac{5}{6}$
62. $|3x + 5| < 0$
65. A(n) _____ is a correspondence such that each member of the domain corresponds to at least one member of the range.
66. A(n) _____ is a correspondence such that each member of the domain corresponds to exactly one member of the range.
67. _____ are given by equations of the type $y = b$, or $f(x) = b$.
68. Nonvertical lines are _____ if and only if they have the same slope and different y -intercepts.
69. A function f is said to be _____ on an open interval I if, for all a and b in that interval, $a < b$ implies $f(a) > f(b)$.
70. For an equation $y = f(x)$, if replacing x with $-x$ produces an equivalent equation, then the graph is _____.

Skill Maintenance

In each of Exercises 63–70, fill in the blank with the correct term. Some of the given choices will not be used.

distance formula	symmetric with respect to the x -axis
midpoint formula	symmetric with respect to the y -axis
function relation	symmetric with respect to the origin
x -intercept	increasing
y -intercept	decreasing
perpendicular	constant
parallel	
horizontal lines	
vertical lines	

63. A(n) _____ is a point $(0, b)$.
64. The _____ is $d = \sqrt{(x_2 - x_1)^2 + (y_2 - y_1)^2}$.

Synthesis

Solve.

71. $|3x - 1| > 5x - 2$
72. $|x + 2| \leq |x - 5|$
73. $|p - 4| + |p + 4| < 8$
74. $|x| + |x + 1| < 10$
75. $|x - 3| + |2x + 5| > 6$

Chapter 3 Summary and Review

STUDY GUIDE

KEY TERMS AND CONCEPTS

SECTION 3.1: THE COMPLEX NUMBERS

The number i is defined such that $i = \sqrt{-1}$ and $i^2 = -1$.

A **complex number** is a number of the form $a + bi$, where a and b are real numbers. The number a is said to be the **real part** of $a + bi$, and the number b is said to be the **imaginary part** of $a + bi$.

To **add or subtract complex numbers**, we add or subtract the real parts, and we add or subtract the imaginary parts.

When we **multiply complex numbers**, we must keep in mind the fact that $i^2 = -1$.

Note that $\sqrt{a} \cdot \sqrt{b} \neq \sqrt{ab}$ when \sqrt{a} and \sqrt{b} are not real numbers.

The **conjugate of a complex number** $a + bi$ is $a - bi$. The numbers $a + bi$ and $a - bi$ are **complex conjugates**.

Conjugates are used when we **divide complex numbers**.

EXAMPLE

Express each number in terms of i .

$$\begin{aligned}\sqrt{-5} &= \sqrt{-1 \cdot 5} = \sqrt{-1} \cdot \sqrt{5} = i\sqrt{5}, \text{ or } \sqrt{5}i; \\ -\sqrt{-36} &= -\sqrt{-1 \cdot 36} = -\sqrt{-1} \cdot \sqrt{36} = -i \cdot 6 = -6i\end{aligned}$$

Add or subtract.

$$\begin{aligned}(-3 + 4i) + (5 - 8i) &= (-3 + 5) + (4i - 8i) \\ &= 2 - 4i; \\ (6 - 7i) - (10 + 3i) &= (6 - 10) + (-7i - 3i) \\ &= -4 - 10i\end{aligned}$$

Multiply.

$$\begin{aligned}\sqrt{-4} \cdot \sqrt{-100} &= \sqrt{-1} \cdot \sqrt{4} \cdot \sqrt{-1} \cdot \sqrt{100} \\ &= i \cdot 2 \cdot i \cdot 10 \\ &= i^2 \cdot 20 \\ &= -1 \cdot 20 \quad i^2 = -1 \\ &= -20;\end{aligned}$$

$$\begin{aligned}(2 - 5i)(3 + i) &= 6 + 2i - 15i - 5i^2 \\ &= 6 - 13i - 5(-1) \\ &= 6 - 13i + 5 \\ &= 11 - 13i\end{aligned}$$

Divide.

$$\begin{aligned}\frac{5 - 2i}{3 + i} &= \frac{5 - 2i}{3 + i} \cdot \frac{3 - i}{3 - i} \quad 3 - i \text{ is the conjugate of the divisor, } 3 + i. \\ &= \frac{15 - 5i - 6i + 2i^2}{9 - i^2} \\ &= \frac{15 - 11i - 2}{9 + 1} \quad i^2 = -1 \\ &= \frac{13 - 11i}{10} \\ &= \frac{13}{10} - \frac{11}{10}i\end{aligned}$$

SECTION 3.2: QUADRATIC EQUATIONS, FUNCTIONS, ZEROS, AND MODELS

A **quadratic equation** is an equation that can be written in the form

$$ax^2 + bx + c = 0, \quad a \neq 0,$$

where a , b , and c are real numbers.

A **quadratic function** f is a function that can be written in the form

$$f(x) = ax^2 + bx + c, \quad a \neq 0,$$

where a , b , and c are real numbers.

The **zeros** of a quadratic function $f(x) = ax^2 + bx + c$ are the *solutions* of the associated quadratic equation $ax^2 + bx + c = 0$.

The Principle of Zero Products

If $ab = 0$ is true, then $a = 0$ or $b = 0$, and if $a = 0$ or $b = 0$, then $ab = 0$.

The Principle of Square Roots

If $x^2 = k$, then $x = \sqrt{k}$ or $x = -\sqrt{k}$.

To solve a quadratic equation by **completing the square**:

1. Isolate the terms with variables on one side of the equation and arrange them in descending order.
2. Divide by the coefficient of the squared term if that coefficient is not 1.
3. Complete the square by taking half the coefficient of the first-degree term and adding its square on both sides of the equation.
4. Express one side of the equation as the square of a binomial.
5. Use the principle of square roots.
6. Solve for the variable.

$3x^2 - 2x + 4 = 0$ and $5 - 4x = x^2$ are examples of quadratic equations. The equation $3x^2 - 2x + 4 = 0$ is written in **standard form**.

The functions $f(x) = 2x^2 + x + 1$ and $f(x) = 5x^2 - 4$ are examples of quadratic functions.

Solve: $3x^2 - 4 = 11x$.

$$3x^2 - 4 = 11x$$

$$3x^2 - 11x - 4 = 0$$

Subtracting $11x$ on both sides to get 0 on one side of the equation
Factoring

$$(3x + 1)(x - 4) = 0$$

$$3x + 1 = 0 \quad \text{or} \quad x - 4 = 0$$

Using the principle of zero products

$$3x = -1 \quad \text{or} \quad x = 4$$

$$x = -\frac{1}{3} \quad \text{or} \quad x = 4$$

Solve: $3x^2 - 18 = 0$.

$$3x^2 - 18 = 0$$

$$3x^2 = 18$$

$$x^2 = 6$$

$$x = \sqrt{6} \quad \text{or} \quad x = -\sqrt{6}$$

Adding 18 on both sides
Dividing by 3 on both sides
Using the principle of square roots

Solve: $2x^2 - 3 = 6x$.

$$2x^2 - 3 = 6x$$

$$2x^2 - 6x - 3 = 0$$

$$2x^2 - 6x = 3$$

Subtracting $6x$
Adding 3

$$x^2 - 3x = \frac{3}{2}$$

Dividing by 2 to make the x^2 -coefficient 1

$$x^2 - 3x + \frac{9}{4} = \frac{3}{2} + \frac{9}{4}$$

Completing the square: $\frac{1}{2}(-3) = -\frac{3}{2}$ and $(-\frac{3}{2})^2 = \frac{9}{4}$; adding $\frac{9}{4}$

$$\left(x - \frac{3}{2}\right)^2 = \frac{15}{4}$$

Factoring and simplifying

$$x - \frac{3}{2} = \pm \frac{\sqrt{15}}{2}$$

Using the principle of square roots and the quotient rule for radicals

$$x = \frac{3}{2} \pm \frac{\sqrt{15}}{2} = \frac{3 \pm \sqrt{15}}{2}$$

The solutions of $ax^2 + bx + c = 0$, $a \neq 0$, can be found using the **quadratic formula**:

$$x = \frac{-b \pm \sqrt{b^2 - 4ac}}{2a}$$

Discriminant

For $ax^2 + bx + c = 0$, where a , b , and c are real numbers:

$b^2 - 4ac = 0 \rightarrow$ One real-number solution;

$b^2 - 4ac > 0 \rightarrow$ Two different real-number solutions;

$b^2 - 4ac < 0 \rightarrow$ Two different imaginary-number solutions, complex conjugates.

Equations **reducible to quadratic**, or **quadratic in form**, can be treated as quadratic equations if a suitable substitution is made.

Solve: $x^2 - 6 = 3x$.

$$x^2 - 6 = 3x$$

$$x^2 - 3x - 6 = 0 \quad \text{Standard form}$$

$$a = 1, b = -3, c = -6$$

$$x = \frac{-b \pm \sqrt{b^2 - 4ac}}{2a}$$

$$= \frac{-(-3) \pm \sqrt{(-3)^2 - 4(1)(-6)}}{2 \cdot 1}$$

$$= \frac{3 \pm \sqrt{9 + 24}}{2}$$

$$= \frac{3 \pm \sqrt{33}}{2} \quad \text{Exact solutions}$$

Using a calculator, we approximate the solutions to be 4.372 and -1.372 .

For the equation above, $x^2 - 6 = 3x$, we see that $b^2 - 4ac$ is 33. Since 33 is positive, there are two different real-number solutions.

For $2x^2 - x + 4 = 0$, with $a = 2$, $b = -1$, and $c = 4$, the discriminant, $(-1)^2 - 4 \cdot 2 \cdot 4 = 1 - 32 = -31$, is negative, so there are two different imaginary-number (or nonreal) solutions.

For $x^2 - 6x + 9 = 0$, with $a = 1$, $b = -6$, and $c = 9$, the discriminant, $(-6)^2 - 4 \cdot 1 \cdot 9 = 36 - 36 = 0$, is 0 so there is one real-number solution.

Solve.

$$x^4 - x^2 - 12 = 0 \quad \text{Let } u = x^2. \text{ Then } u^2 = (x^2)^2 = x^4.$$

$$u^2 - u - 12 = 0 \quad \text{Substituting}$$

$$(u - 4)(u + 3) = 0$$

$$u - 4 = 0 \quad \text{or} \quad u + 3 = 0$$

$$u = 4 \quad \text{or} \quad u = -3 \quad \text{Solving for } u$$

$$x^2 = 4 \quad \text{or} \quad x^2 = -3$$

$$x = \pm 2 \quad \text{or} \quad x = \pm \sqrt{3}i \quad \text{Solving for } x$$

SECTION 3.3: ANALYZING GRAPHS OF QUADRATIC FUNCTIONS

Graphing Quadratic Equations

The graph of the function $f(x) = a(x - h)^2 + k$ is a parabola that:

- opens up if $a > 0$ and down if $a < 0$;
- has (h, k) as the vertex;
- has $x = h$ as the axis of symmetry;
- has k as a minimum value (output) if $a > 0$;
- has k as a maximum value if $a < 0$.

We can use a modification of the technique of completing the square as an aid in analyzing and graphing quadratic functions.

Find the vertex, the axis of symmetry, and the maximum or minimum value of $f(x) = 2x^2 + 12x + 12$.

$$f(x) = 2x^2 + 12x + 12$$

$$= 2(x^2 + 6x) + 12$$

$$= 2(x^2 + 6x + 9 - 9) + 12$$

$$= 2(x^2 + 6x + 9) - 2 \cdot 9 + 12$$

$$= 2(x + 3)^2 - 6$$

$$= 2[x - (-3)]^2 + (-6)$$

Note that 9 completes the square for $x^2 + 6x$.

Adding 9 - 9, or 0, inside the parentheses

Using the distributive law to remove -9 from within the parentheses

(Continued)

The function is now written in the form $f(x) = a(x - h)^2 + k$ with $a = 2$, $h = -3$, and $k = -6$. Because $a > 0$, we know the graph opens up and thus the function has a minimum value. We also know the following:

Vertex (h, k) : $(-3, -6)$;

Axis of symmetry $x = h$: $x = -3$;

Minimum value of the function k : -6 .

To graph the function, we first plot the vertex and then find several points on either side of it. We plot these points and connect them with a smooth curve.

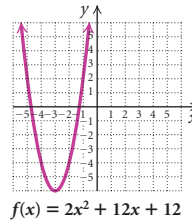

The Vertex of a Parabola

The **vertex** of the graph of $f(x) = ax^2 + bx + c$ is

$$\left(-\frac{b}{2a}, f\left(-\frac{b}{2a}\right) \right).$$

We calculate the x -coordinate.

We substitute to find the y -coordinate.

Some applied problems can be solved by finding the maximum or minimum value of a quadratic function.

Find the vertex of the function $f(x) = -3x^2 + 6x + 1$.

$$\begin{aligned} -\frac{b}{2a} &= -\frac{6}{2(-3)} = 1 \\ f(1) &= -3 \cdot 1^2 + 6 \cdot 1 + 1 = 4 \end{aligned}$$

The vertex is $(1, 4)$.

See Examples 5–7 on pp. 262–265.

SECTION 3.4: SOLVING RATIONAL EQUATIONS AND RADICAL EQUATIONS

A **rational equation** is an equation containing one or more rational expressions. When we solve a rational equation, we usually first multiply by the least common denominator (LCD) of all the denominators to clear the fractions.

CAUTION! When we multiply by an expression containing a variable, we might not obtain an equation equivalent to the original equation, so we *must* check the possible solutions obtained by substituting them in the original equation.

Solve.

$$\begin{aligned} \frac{5}{x+2} - \frac{4}{x^2-4} &= \frac{x-3}{x-2} \\ \frac{5}{x+2} - \frac{4}{(x+2)(x-2)} &= \frac{x-3}{x-2} && \text{The LCD is } (x+2)(x-2). \\ (x+2)(x-2) \left(\frac{5}{x+2} - \frac{4}{(x+2)(x-2)} \right) &= (x+2)(x-2) \cdot \frac{x-3}{x-2} \\ 5(x-2) - 4 &= (x+2)(x-3) \\ 5x - 10 - 4 &= x^2 - x - 6 \\ 5x - 14 &= x^2 - x - 6 \\ 0 &= x^2 - 6x + 8 \\ 0 &= (x-2)(x-4) \\ x - 2 = 0 & \text{ or } x - 4 = 0 \\ x = 2 & \text{ or } x = 4 \end{aligned}$$

The number 2 does not check, but 4 does. The solution is 4.

A **radical equation** is an equation that contains one or more radicals. We use the **principle of powers** to solve radical equations.

For any positive integer n :

If $a = b$ is true, then $a^n = b^n$ is true.

CAUTION! If $a^n = b^n$ is true, it is not necessarily true that $a = b$, so we *must* check the possible solutions obtained by substituting them in the original equation.

Solve.

$$\sqrt{x+2} + \sqrt{x-1} = 3$$

$$\sqrt{x+2} = 3 - \sqrt{x-1} \quad \text{Isolating one radical}$$

$$(\sqrt{x+2})^2 = (3 - \sqrt{x-1})^2$$

$$x+2 = 9 - 6\sqrt{x-1} + (x-1)$$

$$x+2 = 8 - 6\sqrt{x-1} + x$$

$$-6 = -6\sqrt{x-1} \quad \text{Isolating the remaining radical}$$

$$1 = \sqrt{x-1} \quad \text{Dividing by } -6$$

$$1^2 = (\sqrt{x-1})^2$$

$$1 = x - 1$$

$$2 = x$$

The number 2 checks. It is the solution.

SECTION 3.5: SOLVING EQUATIONS AND INEQUALITIES WITH ABSOLUTE VALUE

We use the following property to **solve equations with absolute value**.

For $a > 0$ and an algebraic expression X :

$|X| = a$ is equivalent to $X = -a$ or $X = a$.

Solve.

$$|x+1| = 4$$

$$x+1 = -4 \quad \text{or} \quad x+1 = 4$$

$$x = -5 \quad \text{or} \quad x = 3$$

Both numbers check.

The following properties are used to **solve inequalities with absolute value**.

For $a > 0$ and an algebraic expression X :

$|X| < a$ is equivalent to $-a < X < a$.

$|X| > a$ is equivalent to $X < -a$ or $X > a$.

Similar statements hold for

$|X| \leq a$ and $|X| \geq a$.

Solve.

$$|x-2| < 3$$

$$-3 < x-2 < 3$$

$$-1 < x < 5 \quad \text{Adding 2}$$

The solution set is $\{x | -1 < x < 5\}$, or $(-1, 5)$.

$$|3x| \geq 6$$

$$3x \leq -6 \quad \text{or} \quad 3x \geq 6$$

$$x \leq -2 \quad \text{or} \quad x \geq 2 \quad \text{Dividing by 3}$$

The solution set is $\{x | x \leq -2 \text{ or } x \geq 2\}$, or $(-\infty, -2] \cup [2, \infty)$.

REVIEW EXERCISES

Determine whether the statement is true or false.

- We can use the quadratic formula to solve any quadratic equation. [3.2]
- The function $f(x) = -3(x+4)^2 - 1$ has a maximum value. [3.3]
- For any positive integer n , if $a^n = b^n$ is true, then $a = b$ is true. [3.4]
- An equation with absolute value cannot have two negative-number solutions. [3.5]

Solve. [3.2]

5. $(2y + 5)(3y - 1) = 0$

6. $x^2 + 4x - 5 = 0$

7. $3x^2 + 2x = 8$

8. $5x^2 = 15$

9. $x^2 + 10 = 0$

Find the zero(s) of the function. [3.2]

10. $f(x) = x^2 - 2x + 1$

11. $f(x) = x^2 + 2x - 15$

12. $f(x) = 2x^2 - x - 5$

13. $f(x) = 3x^2 + 2x + 3$

Solve.

14. $\frac{5}{2x + 3} + \frac{1}{x - 6} = 0$ [3.4]

15. $\frac{3}{8x + 1} + \frac{8}{2x + 5} = 1$ [3.4]

16. $\sqrt{5x + 1} - 1 = \sqrt{3x}$ [3.4]

17. $\sqrt{x - 1} - \sqrt{x - 4} = 1$ [3.4]

18. $|x - 4| = 3$ [3.5]

19. $|2y + 7| = 9$ [3.5]

Solve and write interval notation for the solution set.

Then graph the solution set. [3.5]

20. $|5x| \geq 15$ 21. $|3x + 4| < 10$

22. $|1 - 6x| < 5$ 23. $|x + 4| \geq 2$

24. Solve $\frac{1}{M} + \frac{1}{N} = \frac{1}{P}$ for P . [3.4]

Express in terms of i . [3.1]

25. $-\sqrt{-40}$

26. $\sqrt{-12} \cdot \sqrt{-20}$

27. $\frac{\sqrt{-49}}{-\sqrt{-64}}$

Simplify each of the following. Write the answer in the form $a + bi$, where a and b are real numbers. [3.1]

28. $(6 + 2i) + (-4 - 3i)$

29. $(3 - 5i) - (2 - i)$

30. $(6 + 2i)(-4 - 3i)$

31. $\frac{2 - 3i}{1 - 3i}$

32. i^{23}

Solve by completing the square to obtain exact solutions. Show your work. [3.2]

33. $x^2 - 3x = 18$

34. $3x^2 - 12x - 6 = 0$

Solve. Give exact solutions. [3.2]

35. $3x^2 + 10x = 8$

36. $r^2 - 2r + 10 = 0$

37. $x^2 = 10 + 3x$

38. $x = 2\sqrt{x} - 1$

39. $y^4 - 3y^2 + 1 = 0$

40. $(x^2 - 1)^2 - (x^2 - 1) - 2 = 0$

41. $(p - 3)(3p + 2)(p + 2) = 0$

42. $x^3 + 5x^2 - 4x - 20 = 0$

In Exercises 43 and 44, complete the square to:

- a) find the vertex;
- b) find the axis of symmetry;
- c) determine whether there is a maximum or minimum value and find that value;
- d) find the range; and
- e) graph the function. [3.3]

43. $f(x) = -4x^2 + 3x - 1$

44. $f(x) = 5x^2 - 10x + 3$

In Exercises 45–48, match the equation with one of the figures (a)–(d), which follow. [3.3]

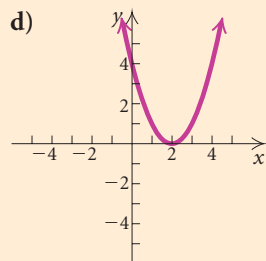
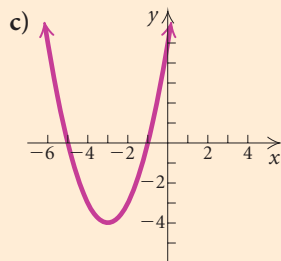
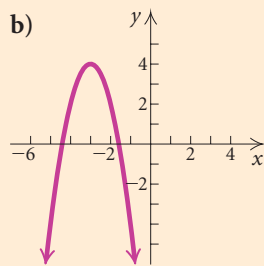
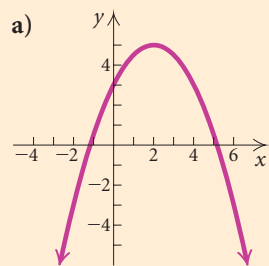

45. $y = (x - 2)^2$

46. $y = (x + 3)^2 - 4$

47. $y = -2(x + 3)^2 + 4$

48. $y = -\frac{1}{2}(x - 2)^2 + 5$

49. **Legs of a Right Triangle.** The hypotenuse of a right triangle is 50 ft. One leg is 10 ft longer than the other. What are the lengths of the legs? [3.2]

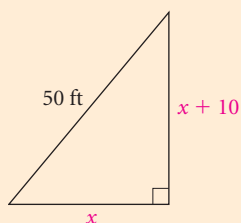

50. **Bicycling Speed.** Logan and Cassidy leave a campsite, Logan biking due north and Cassidy biking due east. Logan bikes 7 km/h slower than Cassidy. After 4 hr, they are 68 km apart. Find the speed of each bicyclist. [3.2]

51. **Sidewalk Width.** A 60-ft by 80-ft parking lot is torn up to install a sidewalk of uniform width

around its perimeter. The new area of the parking lot is two-thirds of the old area. How wide is the sidewalk? [3.2]

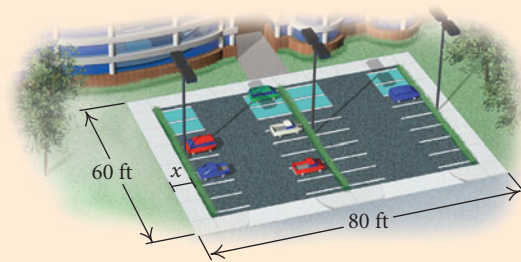

52. **Maximizing Volume.** The Berniers have 24 ft of flexible fencing with which to build a rectangular “toy corral.” If the fencing is 2 ft high, what dimensions should the corral have in order to maximize its volume? [3.3]
53. **Dimensions of a Box.** An open box is made from a 10-cm by 20-cm piece of aluminum by cutting a square from each corner and folding up the edges. The area of the resulting base is 90 cm². What is the length of the sides of the squares? [3.2]

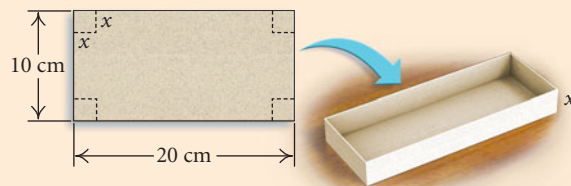

54. Find the zeros of $f(x) = 2x^2 - 5x + 1$. [3.2]

- A. $\frac{5 \pm \sqrt{17}}{2}$ B. $\frac{5 \pm \sqrt{17}}{4}$
 C. $\frac{5 \pm \sqrt{33}}{4}$ D. $\frac{-5 \pm \sqrt{17}}{4}$

55. Solve: $\sqrt{4x + 1} + \sqrt{2x} = 1$. [3.4]

- A. There are two solutions.
 B. There is only one solution. It is less than 1.
 C. There is only one solution. It is greater than 1.
 D. There is no solution.

56. The graph of $f(x) = (x - 2)^2 - 3$ is which of the following? [3.3]

A.

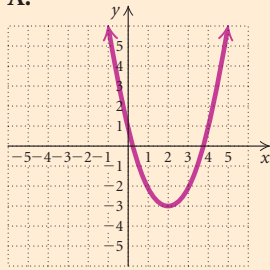

B.

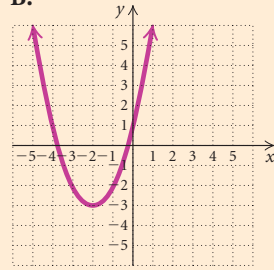

C.

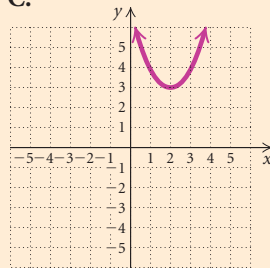

D.

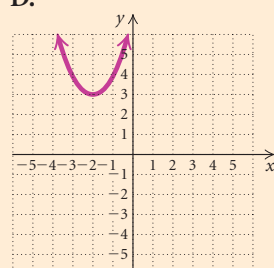

Synthesis

Solve.

57. $\sqrt{\sqrt{\sqrt{x}}} = 2$ [3.4]
 58. $(t - 4)^{4/5} = 3$ [3.4]
 59. $(x - 1)^{2/3} = 4$ [3.4]
 60. $(2y - 2)^2 + y - 1 = 5$ [3.2]
 61. $\sqrt{x + 2} + \sqrt[4]{x + 2} - 2 = 0$ [3.2]
 62. At the beginning of the year, \$3500 was deposited in a savings account. One year later, \$4000 was

deposited in another account. The interest rate was the same for both accounts. At the end of the second year, there was a total of \$8518.35 in the accounts. What was the annual interest rate? [3.2]

63. Find b such that $f(x) = -3x^2 + bx - 1$ has a maximum value of 2. [3.3]

Collaborative Discussion and Writing

64. Is the product of two imaginary numbers always an imaginary number? Explain your answer. [3.1]
 65. Is it possible for a quadratic function to have one real zero and one imaginary zero? Why or why not? [3.2]
 66. If the graphs of

$$f(x) = a_1(x - h_1)^2 + k_1$$

and

$$g(x) = a_2(x - h_2)^2 + k_2$$

have the same shape, what, if anything, can you conclude about the a 's, the h 's, and the k 's? Explain your answer. [3.3]

67. Explain why it is necessary to check the possible solutions of a rational equation. [3.4]
 68. Explain in your own words why it is necessary to check the possible solutions when the principle of powers is used to solve an equation. [3.4]
 69. Explain why $|x| < p$ has no solution for $p \leq 0$. [3.5]
 70. Explain why all real numbers are solutions of $|x| > p$, for $p < 0$. [3.5]

Chapter 3 Test

Solve. Find exact solutions.

- $(2x - 1)(x + 5) = 0$
- $6x^2 - 36 = 0$
- $x^2 + 4 = 0$
- $x^2 - 2x - 3 = 0$
- $x^2 - 5x + 3 = 0$
- $2t^2 - 3t + 4 = 0$
- $x + 5\sqrt{x} - 36 = 0$
- $\frac{3}{3x + 4} + \frac{2}{x - 1} = 2$
- $\sqrt{x + 4} - 2 = 1$
- $\sqrt{x + 4} - \sqrt{x - 4} = 2$
- $|x + 4| = 7$
- $|4y - 3| = 5$

Solve and write interval notation for the solution set. Then graph the solution set.

- $|x + 3| \leq 4$
- $|2x - 1| < 5$
- $|x + 5| > 2$
- $|3 - 2x| \geq 7$
- Solve $\frac{1}{A} + \frac{1}{B} = \frac{1}{C}$ for B.
- Solve $R = \sqrt{3np}$ for n.
- Solve $x^2 + 4x = 1$ by completing the square. Find the exact solutions. Show your work.
- The tallest structure in the United States, at 2063 ft, is the KTHI-TV tower in North Dakota (*Source: The Cambridge Fact Finder*). How long would it take an object falling freely from the top to reach the ground? (Use the formula $s = 16t^2$.)

Express in terms of i .

- $\sqrt{-43}$
- $-\sqrt{-25}$

Simplify.

- $(5 - 2i) - (2 + 3i)$
- $(3 + 4i)(2 - i)$
- $\frac{1 - i}{6 + 2i}$
- i^{33}

Find the zeros of each function.

- $f(x) = 4x^2 - 11x - 3$
- $f(x) = 2x^2 - x - 7$
- For the graph of the function $f(x) = -x^2 + 2x + 8$:
 - Find the vertex.
 - Find the axis of symmetry.
 - State whether there is a maximum or minimum value and find that value.
 - Find the range.
 - Graph the function.
- Maximizing Area.** A homeowner wants to fence a rectangular play yard using 80 ft of fencing. The side of the house will be used as one side of the rectangle. Find the dimensions for which the area is a maximum.
- The graph of $f(x) = x^2 - 2x - 1$ is which of the following?

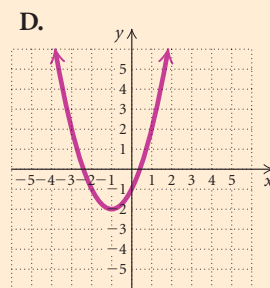
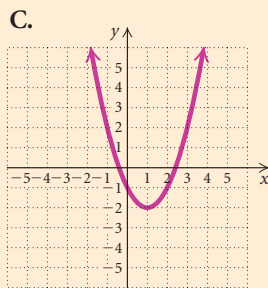
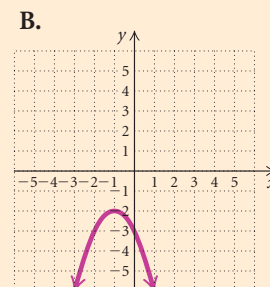
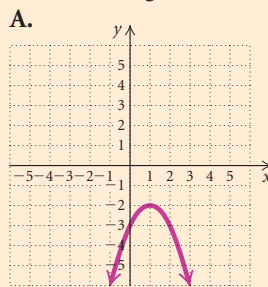

Synthesis

- Find a such that $f(x) = ax^2 - 4x + 3$ has a maximum value of 12.

This page intentionally left blank

Polynomial Functions and Rational Functions

CHAPTER

4



Application

The median price for an existing home in the United States peaked at \$221,900 in 2006 (*Source*: National Association of REALTORS®). The quartic function

$$\begin{aligned}h(x) = & 56.8328x^4 - 1554.7494x^3 \\ & + 10,451.8211x^2 - 5655.7692x \\ & + 140,589.1608,\end{aligned}$$

where x is the number of years since 2000, can be used to estimate the median existing-home price from 2000 to 2009. Estimate the median existing-home price in 2002, in 2005, in 2008, and in 2009.

This problem appears as Exercise 53 in Section 4.1.

4.1 Polynomial Functions and Models

4.2 Graphing Polynomial Functions

Visualizing the Graph

4.3 Polynomial Division; The Remainder Theorem and the Factor Theorem

Mid-Chapter Mixed Review

4.4 Theorems about Zeros of Polynomial Functions

4.5 Rational Functions

Visualizing the Graph

4.6 Polynomial Inequalities and Rational Inequalities

Study Guide

Review Exercises

Chapter Test

Polynomial Functions and Models

4.1

- ▶ Determine the behavior of the graph of a polynomial function using the leading-term test.
- ▶ Factor polynomial functions and find their zeros and their multiplicities.
- ▶ Solve applied problems using polynomial models.

There are many different kinds of functions. The constant, linear, and quadratic functions that we studied in Chapters 1 and 3 are part of a larger group of functions called *polynomial functions*.

Polynomial Function

A **polynomial function** P is given by

$$P(x) = a_n x^n + a_{n-1} x^{n-1} + a_{n-2} x^{n-2} + \cdots + a_1 x + a_0,$$

where the coefficients $a_n, a_{n-1}, \dots, a_1, a_0$ are real numbers and the exponents are whole numbers.

The first nonzero coefficient, a_n , is called the **leading coefficient**. The term $a_n x^n$ is called the **leading term**. The **degree** of the polynomial function is n . Some examples of polynomial functions follow.

POLYNOMIAL FUNCTION	EXAMPLE	DEGREE	LEADING TERM	LEADING COEFFICIENT
Constant	$f(x) = 3$ ($f(x) = 3 = 3x^0$)	0	3	3
Linear	$f(x) = \frac{2}{3}x + 5$ ($f(x) = \frac{2}{3}x + 5 = \frac{2}{3}x^1 + 5$)	1	$\frac{2}{3}x$	$\frac{2}{3}$
Quadratic	$f(x) = 4x^2 - x + 3$	2	$4x^2$	4
Cubic	$f(x) = x^3 + 2x^2 + x - 5$	3	x^3	1
Quartic	$f(x) = -x^4 - 1.1x^3 + 0.3x^2 - 2.8x - 1.7$	4	$-x^4$	-1

The function $f(x) = 0$ can be described in many ways:

$$f(x) = 0 = 0x^2 = 0x^{15} = 0x^{48},$$

and so on. For this reason, we say that the constant function $f(x) = 0$ has no degree.

Functions such as

$$f(x) = \frac{2}{x} + 5, \text{ or } 2x^{-1} + 5, \text{ and } g(x) = \sqrt{x} - 6, \text{ or } x^{1/2} - 6,$$

are *not* polynomial functions because the exponents -1 and $\frac{1}{2}$ are *not* whole numbers.

From our study of functions in Chapters 1–3, we know how to find or at least estimate many characteristics of a polynomial function. Let's consider two examples for review.

Quadratic Function

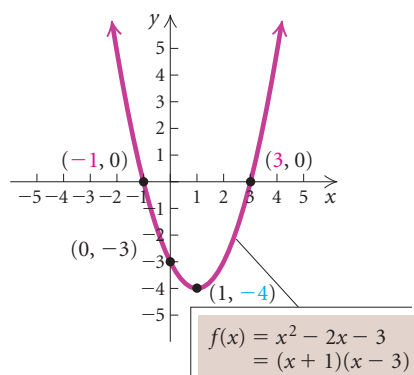

$$\begin{aligned} \text{Function: } f(x) &= x^2 - 2x - 3 \\ &= (x + 1)(x - 3) \end{aligned}$$

$$\text{Zeros: } -1, 3$$

$$\text{x-intercepts: } (-1, 0), (3, 0)$$

$$\text{y-intercept: } (0, -3)$$

$$\text{Minimum: } -4 \text{ at } x = 1$$

$$\text{Maximum: None}$$

$$\text{Domain: All real numbers, } (-\infty, \infty)$$

$$\text{Range: } [-4, \infty)$$

Cubic Function

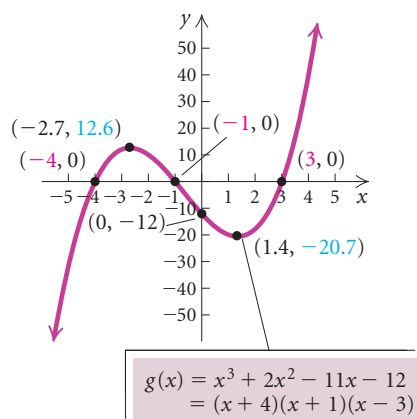

$$\begin{aligned} \text{Function: } g(x) &= x^3 + 2x^2 - 11x - 12 \\ &= (x + 4)(x + 1)(x - 3) \end{aligned}$$

$$\text{Zeros: } -4, -1, 3$$

$$\text{x-intercepts: } (-4, 0), (-1, 0), (3, 0)$$

$$\text{y-intercept: } (0, -12)$$

$$\text{Relative minimum: } -20.7 \text{ at } x = 1.4$$

$$\text{Relative maximum: } 12.6 \text{ at } x = -2.7$$

$$\text{Domain: All real numbers, } (-\infty, \infty)$$

$$\text{Range: All real numbers, } (-\infty, \infty)$$

All graphs of polynomial functions have some characteristics in common. Compare the following graphs. How do the graphs of polynomial functions differ from the graphs of nonpolynomial functions? Describe some characteristics of the graphs of polynomial functions that you observe.

Polynomial Functions

$$f(x) = x^2 + 3x + 1$$

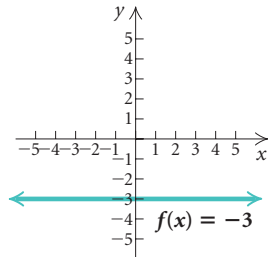
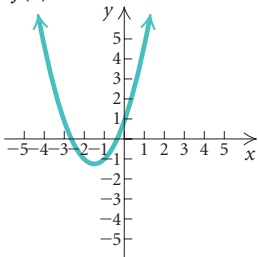

$$f(x) = 2x^3 + x^2 + x - 1$$

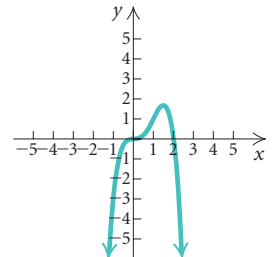
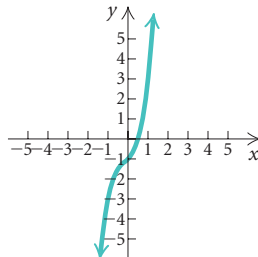

$$f(x) = -x^4 + 2x^3$$

Nonpolynomial Functions

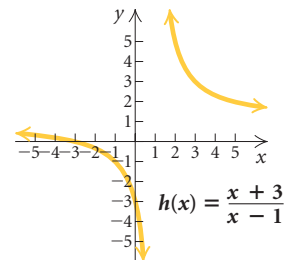
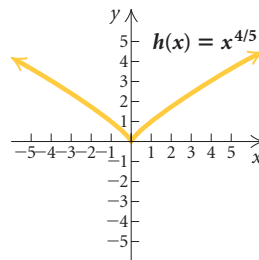
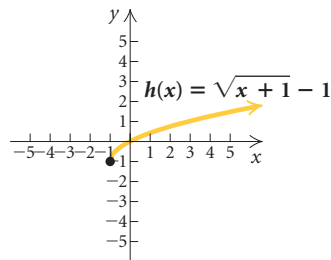
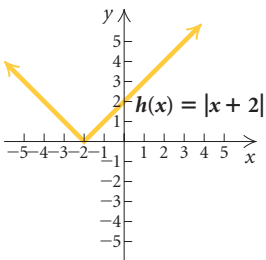

You probably noted that the graph of a polynomial function is *continuous*; that is, it has no holes or breaks. It is also smooth; there are no sharp corners. Furthermore, the *domain* of a polynomial function is the set of all real numbers, $(-\infty, \infty)$.

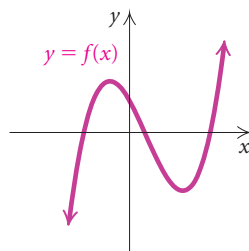

A continuous function

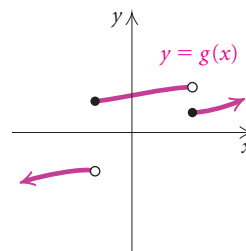

A discontinuous function

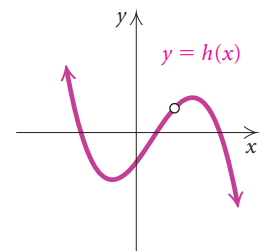

A discontinuous function

► The Leading-Term Test

The behavior of the graph of a polynomial function as x becomes very large ($x \rightarrow \infty$) or very small ($x \rightarrow -\infty$) is referred to as the end behavior of the graph. The leading term of a polynomial function determines its end behavior.

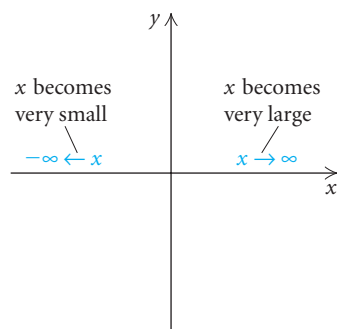

Using the graphs shown below, let's see if we can discover some general patterns by comparing the end behavior of even- and odd-degree functions. We also observe the effect of positive and negative leading coefficients.

Even Degree

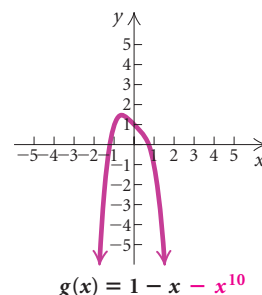
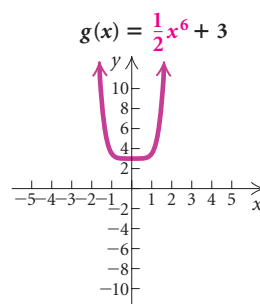
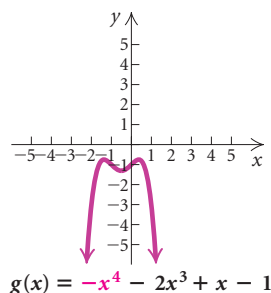
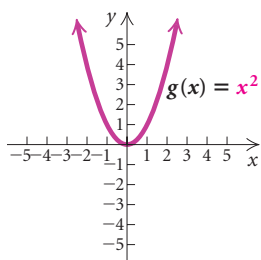

Odd Degree

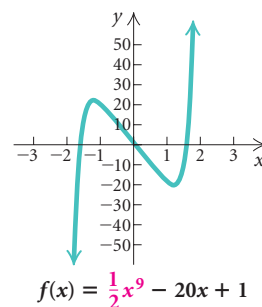
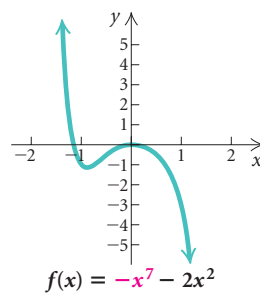
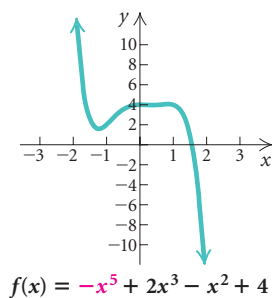
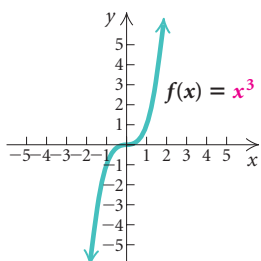

We can summarize our observations as follows.

The Leading-Term Test

If $a_n x^n$ is the leading term of a polynomial function, then the behavior of the graph as $x \rightarrow \infty$ or as $x \rightarrow -\infty$ can be described in one of the four following ways.

n	$a_n > 0$	$a_n < 0$
Even		
Odd		

The  portion of the graph is not determined by this test.

EXAMPLE 1 Using the leading-term test, match each of the following functions with one of the graphs A–D, which follow.

a) $f(x) = 3x^4 - 2x^3 + 3$

b) $f(x) = -5x^3 - x^2 + 4x + 2$

c) $f(x) = x^5 + \frac{1}{4}x + 1$

d) $f(x) = -x^6 + x^5 - 4x^3$

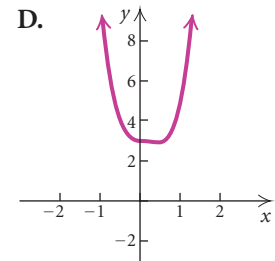
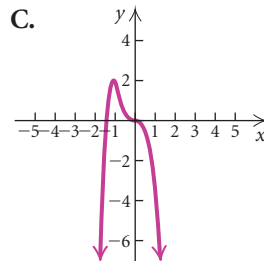
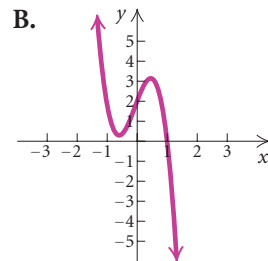
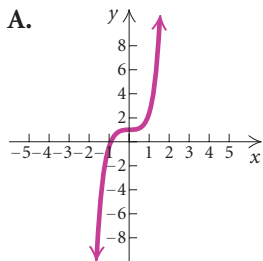

Solution

LEADING TERM	DEGREE OF LEADING TERM	SIGN OF LEADING COEFFICIENT	GRAPH
a) $3x^4$	4, even	Positive	D
b) $-5x^3$	3, odd	Negative	B
c) x^5	5, odd	Positive	A
d) $-x^6$	6, even	Negative	C

 Now Try Exercise 19.

► Finding Zeros of Factored Polynomial Functions

Let's review the meaning of the real zeros of a function and their connection to the x -intercepts of the function's graph.

CONNECTING THE CONCEPTS

Zeros, Solutions, and Intercepts

FUNCTION

Quadratic Polynomial

$$\begin{aligned} g(x) &= x^2 - 2x - 8 \\ &= (x + 2)(x - 4), \end{aligned}$$

or

$$y = (x + 2)(x - 4)$$

ZEROS OF THE FUNCTION; SOLUTIONS OF THE EQUATION

To find the **zeros** of $g(x)$, we solve $g(x) = 0$:

$$\begin{aligned} x^2 - 2x - 8 &= 0 \\ (x + 2)(x - 4) &= 0 \\ x + 2 = 0 \quad \text{or} \quad x - 4 = 0 \\ x = -2 \quad \text{or} \quad x = 4. \end{aligned}$$

The **solutions** of $x^2 - 2x - 8 = 0$ are -2 and 4 . They are the zeros of the function $g(x)$; that is,

$$g(-2) = 0 \quad \text{and} \quad g(4) = 0.$$

ZEROS OF THE FUNCTION; X-INTERCEPTS OF THE GRAPH

The real-number zeros of $g(x)$ are the x -coordinates of the **x -intercepts** of the graph of $y = g(x)$.

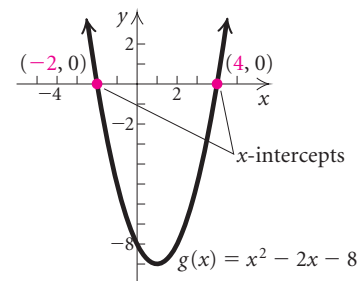

Cubic Polynomial

$$\begin{aligned} h(x) &= x^3 + 2x^2 - 5x - 6 \\ &= x^3 + 2x^2 - 5x - 6 \\ &= (x + 3)(x + 1)(x - 2), \end{aligned}$$

or

$$y = (x + 3)(x + 1)(x - 2)$$

To find the **zeros** of $h(x)$, we solve $h(x) = 0$:

$$\begin{aligned} x^3 + 2x^2 - 5x - 6 &= 0 \\ (x + 3)(x + 1)(x - 2) &= 0 \\ x + 3 = 0 \quad \text{or} \quad x + 1 = 0 \quad \text{or} \quad x - 2 = 0 \\ x = -3 \quad \text{or} \quad x = -1 \quad \text{or} \quad x = 2. \end{aligned}$$

The **solutions** of $x^3 + 2x^2 - 5x - 6 = 0$ are -3 , -1 , and 2 . They are the zeros of the function $h(x)$; that is,

$$\begin{aligned} h(-3) &= 0, \\ h(-1) &= 0, \quad \text{and} \\ h(2) &= 0. \end{aligned}$$

The real-number zeros of $h(x)$ are the x -coordinates of the **x -intercepts** of the graph of $y = h(x)$.

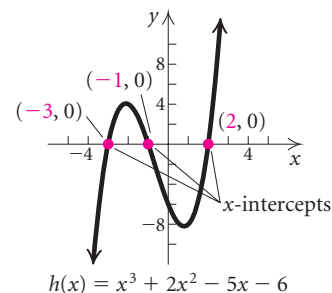

The connection between the real-number zeros of a function and the x -intercepts of the graph of the function is easily seen in the preceding examples. If c is a real zero of a function (that is, $f(c) = 0$), then $(c, 0)$ is an x -intercept of the graph of the function.

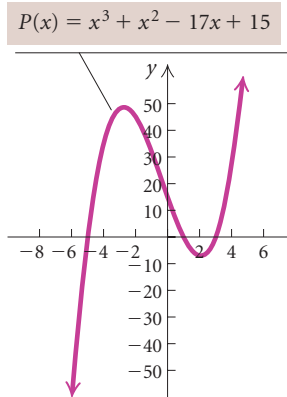

EXAMPLE 2 Consider $P(x) = x^3 + x^2 - 17x + 15$. Determine whether each of the numbers 2 and -5 is a zero of $P(x)$.

Solution We first evaluate $P(2)$:

$$P(2) = (2)^3 + (2)^2 - 17(2) + 15 = -7. \quad \text{Substituting 2 into the polynomial}$$

Since $P(2) \neq 0$, we know that 2 is *not* a zero of the polynomial function.

We then evaluate $P(-5)$:

$$P(-5) = (-5)^3 + (-5)^2 - 17(-5) + 15 = 0. \quad \text{Substituting -5 into the polynomial}$$

Since $P(-5) = 0$, we know that -5 is a zero of $P(x)$.

➔ Now Try Exercise 23.

Let's take a closer look at the polynomial function

$$h(x) = x^3 + 2x^2 - 5x - 6$$

(see Connecting the Concepts on p. 301). The factors of $h(x)$ are

$$x + 3, \quad x + 1, \quad \text{and} \quad x - 2,$$

and the zeros are

$$-3, \quad -1, \quad \text{and} \quad 2.$$

We note that when the polynomial is expressed as a product of linear factors, each factor determines a zero of the function. Thus if we know the linear factors of a polynomial function $f(x)$, we can easily find the zeros of $f(x)$ by solving the equation $f(x) = 0$ using the principle of zero products.

EXAMPLE 3 Find the zeros of

$$\begin{aligned} f(x) &= 5(x - 2)(x - 2)(x - 2)(x + 1) \\ &= 5(x - 2)^3(x + 1). \end{aligned}$$

Solution To solve the equation $f(x) = 0$, we use the principle of zero products, solving $x - 2 = 0$ and $x + 1 = 0$. The zeros of $f(x)$ are 2 and -1 .

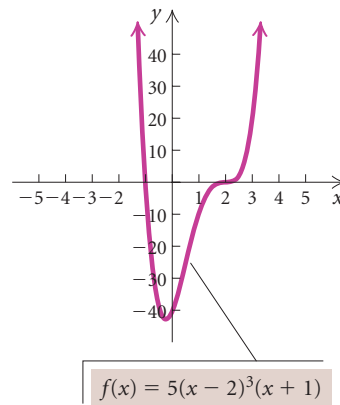

PRINCIPLE OF ZERO PRODUCTS

REVIEW SECTION 3.2

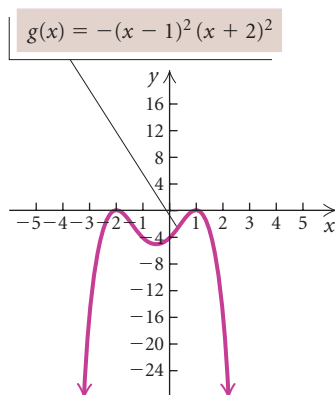

EXAMPLE 4 Find the zeros of

$$\begin{aligned} g(x) &= -(x - 1)(x - 1)(x + 2)(x + 2) \\ &= -(x - 1)^2(x + 2)^2. \end{aligned}$$

Solution To solve the equation $g(x) = 0$, we use the principle of zero products, solving $x - 1 = 0$ and $x + 2 = 0$. The zeros of $g(x)$ are 1 and -2 .

Let's consider the occurrences of the zeros in the functions in Examples 3 and 4 and their relationship to the graphs of those functions. In Example 3, the factor $x - 2$ occurs three times. In a case like this, we say that the zero we obtain from this factor, 2, has a **multiplicity** of 3. The factor $x + 1$ occurs one time. The zero we obtain from this factor, -1 , has a *multiplicity* of 1.

In Example 4, the factors $x - 1$ and $x + 2$ each occur two times. Thus both zeros, 1 and -2 , have a *multiplicity* of 2.

Note, in Example 3, that the zeros have odd multiplicities and the graph crosses the x -axis at both -1 and 2. But in Example 4, the zeros have even multiplicities and the graph is tangent to (touches but does not cross) the x -axis at -2 and 1. This leads us to the following generalization.

Even Multiplicity and Odd Multiplicity

If $(x - c)^k$, $k \geq 1$, is a factor of a polynomial function $P(x)$ and $(x - c)^{k+1}$ is not a factor and:

- k is odd, then the graph crosses the x -axis at $(c, 0)$;
- k is even, then the graph is tangent to the x -axis at $(c, 0)$.

TECHNOLOGY CONNECTION

Using the Zero method, we can determine the zeros of the function in Example 5. The window below shows the calculator display when we find the leftmost zero. The other zeros, 2 and 3, can be found in the same manner.

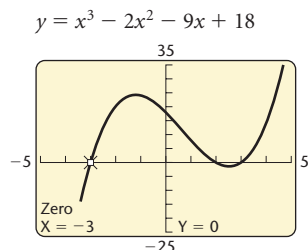

(Continued)

Some polynomials can be factored by grouping. Then we use the principle of zero products to find their zeros.

EXAMPLE 5 Find the zeros of

$$f(x) = x^3 - 2x^2 - 9x + 18.$$

Solution We factor by grouping, as follows:

$$\begin{aligned} f(x) &= x^3 - 2x^2 - 9x + 18 \\ &= x^2(x - 2) - 9(x - 2) \end{aligned}$$

$$\begin{aligned} &= (x - 2)(x^2 - 9) \\ &= (x - 2)(x + 3)(x - 3). \end{aligned}$$

Grouping x^3 with $-2x^2$ and $-9x$ with 18 and factoring each group

Factoring out $x - 2$

Factoring $x^2 - 9$

Then, by the principle of zero products, the solutions of the equation $f(x) = 0$ are 2, -3 , and 3. These are the zeros of $f(x)$.

Now Try Exercise 39.

Find the real zeros of the function f given by $f(x) = 0.1x^3 - 0.6x^2 - 0.1x + 2$. Approximate the zeros to three decimal places.

We use a graphing calculator to create a graph that clearly shows the curvature. It appears that there are three zeros, one near -2 , one near 2 , and one near 6 . We use the ZERO feature to find them. The zeros are approximately -1.680 , 2.154 , and 5.526 .

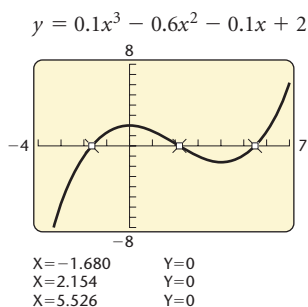

Other factoring techniques can also be used.

EXAMPLE 6 Find the zeros of

$$f(x) = x^4 + 4x^2 - 45.$$

Solution We factor as follows:

$$f(x) = x^4 + 4x^2 - 45 = (x^2 - 5)(x^2 + 9).$$

We now solve the equation $f(x) = 0$ to determine the zeros. We use the principle of zero products:

$$(x^2 - 5)(x^2 + 9) = 0$$

$$x^2 - 5 = 0 \quad \text{or} \quad x^2 + 9 = 0$$

$$x^2 = 5 \quad \text{or} \quad x^2 = -9$$

$$x = \pm\sqrt{5} \quad \text{or} \quad x = \pm\sqrt{-9} = \pm 3i.$$

The solutions are $\pm\sqrt{5}$ and $\pm 3i$. These are the zeros of $f(x)$.

Now Try Exercise 37.

Only the real-number zeros of a function correspond to the x -intercepts of its graph. For instance, the real-number zeros of the function in Example 6, $-\sqrt{5}$ and $\sqrt{5}$, can be seen on the graph of the function below, but the non-real zeros, $-3i$ and $3i$, cannot.

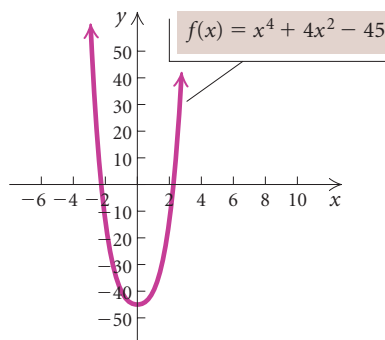

Every polynomial function of degree n , with $n \geq 1$, has at least one zero and at most n zeros.

This is often stated as follows: “Every polynomial function of degree n , with $n \geq 1$, has *exactly* n zeros.” This statement is compatible with the preceding statement, if one takes multiplicities into account.

Polynomial Models

Polynomial functions have many uses as models in science, engineering, and business. The simplest use of polynomial functions in applied problems occurs when we merely evaluate a polynomial function. In such cases, a model has already been developed.

EXAMPLE 7 *Ibuprofen in the Bloodstream.* The polynomial function

$$M(t) = 0.5t^4 + 3.45t^3 - 96.65t^2 + 347.7t$$

can be used to estimate the number of milligrams of the pain relief medication ibuprofen in the bloodstream t hours after 400 mg of the medication has been taken. Find the number of milligrams in the bloodstream at $t = 0, 0.5, 1, 1.5,$ and so on, up to 6 hr. Round the function values to the nearest tenth.

Solution Using a calculator, we compute function values:

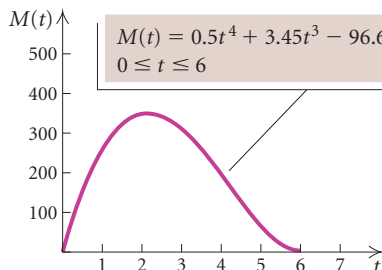

$$\begin{array}{ll} M(0) = 0, & M(3.5) = 255.9, \\ M(0.5) = 150.2, & M(4) = 193.2, \\ M(1) = 255, & M(4.5) = 126.9, \\ M(1.5) = 318.3, & M(5) = 66, \\ M(2) = 344.4, & M(5.5) = 20.2, \\ M(2.5) = 338.6, & M(6) = 0. \\ M(3) = 306.9, & \end{array}$$

Now Try Exercise 49.

Recall that the domain of a polynomial function, unless restricted by a statement of the function, is $(-\infty, \infty)$. The implications of the application in Example 7 restrict the domain of the function. If we assume that a patient had not taken any of the medication before, it seems reasonable that $M(0) = 0$; that is, at time 0, there is 0 mg of the medication in the bloodstream. After the medication has been taken, $M(t)$ will be positive for a period of time and eventually decrease back to 0 when $t = 6$ and not increase again (unless another dose is taken). Thus the restricted domain is $[0, 6]$.

TECHNOLOGY CONNECTION

X	Y1
0	0
.5	150.15
1	255
1.5	318.26
2	344.4
2.5	338.63
3	306.9

$$y = 0.5x^4 + 3.45x^3 - 96.65x^2 + 347.7x$$

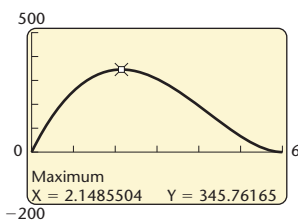

We can evaluate the function in Example 7 with the TABLE feature of a graphing calculator set in AUTO mode. We start at 0 and use a step-value of 0.5.

As discussed above, the domain of $M(t)$ is $[0, 6]$. To determine the range, we find the relative maximum value of the function using the MAXIMUM feature.

The maximum is about 345.76 mg. It occurs approximately 2.15 hr, or 2 hr 9 min, after the initial dose has been taken. The range is about $[0, 345.76]$.



4.1

Exercise Set

Determine the leading term, the leading coefficient, and the degree of the polynomial. Then classify the polynomial function as constant, linear, quadratic, cubic, or quartic.

- $g(x) = \frac{1}{2}x^3 - 10x + 8$
- $f(x) = 15x^2 - 10 + 0.11x^4 - 7x^3$
- $h(x) = 0.9x - 0.13$
- $f(x) = -6$
- $g(x) = 305x^4 + 4021$
- $h(x) = 2.4x^3 + 5x^2 - x + \frac{7}{8}$
- $h(x) = -5x^2 + 7x^3 + x^4$
- $f(x) = 2 - x^2$
- $g(x) = 4x^3 - \frac{1}{2}x^2 + 8$
- $f(x) = 12 + x$

In Exercises 11–18, select one of the following four sketches to describe the end behavior of the graph of the function.

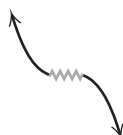
- a) 
- b) 
- c) 
- d) 

- $f(x) = -3x^3 - x + 4$
- $f(x) = \frac{1}{4}x^4 + \frac{1}{2}x^3 - 6x^2 + x - 5$
- $f(x) = -x^6 + \frac{3}{4}x^4$
- $f(x) = \frac{2}{5}x^5 - 2x^4 + x^3 - \frac{1}{2}x + 3$
- $f(x) = -3.5x^4 + x^6 + 0.1x^7$
- $f(x) = -x^3 + x^5 - 0.5x^6$
- $f(x) = 10 + \frac{1}{10}x^4 - \frac{2}{5}x^3$
- $f(x) = 2x + x^3 - x^5$

In Exercises 19–22, use the leading-term test to match the function with one of the graphs (a)–(d), which follow.

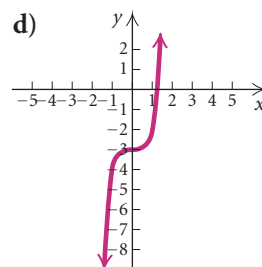
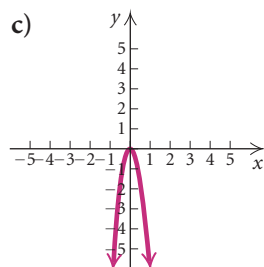
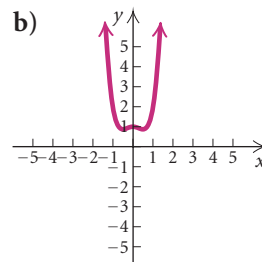
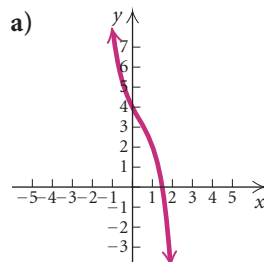

- $f(x) = -x^6 + 2x^5 - 7x^2$
- $f(x) = 2x^4 - x^2 + 1$
- $f(x) = x^5 + \frac{1}{10}x - 3$
- $f(x) = -x^3 + x^2 - 2x + 4$
- Use substitution to determine whether 4, 5, and -2 are zeros of

$$f(x) = x^3 - 9x^2 + 14x + 24.$$
- Use substitution to determine whether 2, 3, and -1 are zeros of

$$f(x) = 2x^3 - 3x^2 + x + 6.$$
- Use substitution to determine whether 2, 3, and -1 are zeros of

$$g(x) = x^4 - 6x^3 + 8x^2 + 6x - 9.$$
- Use substitution to determine whether 1, -2 , and 3 are zeros of

$$g(x) = x^4 - x^3 - 3x^2 + 5x - 2.$$

Find the zeros of the polynomial function and state the multiplicity of each.

27. $f(x) = (x + 3)^2(x - 1)$
28. $f(x) = (x + 5)^3(x - 4)(x + 1)^2$
29. $f(x) = -2(x - 4)(x - 4)(x - 4)(x + 6)$
30. $f(x) = \left(x + \frac{1}{2}\right)(x + 7)(x + 7)(x + 5)$
31. $f(x) = (x^2 - 9)^3$
32. $f(x) = (x^2 - 4)^2$
33. $f(x) = x^3(x - 1)^2(x + 4)$
34. $f(x) = x^2(x + 3)^2(x - 4)(x + 1)^4$
35. $f(x) = -8(x - 3)^2(x + 4)^3x^4$
36. $f(x) = (x^2 - 5x + 6)^2$
37. $f(x) = x^4 - 4x^2 + 3$
38. $f(x) = x^4 - 10x^2 + 9$
39. $f(x) = x^3 + 3x^2 - x - 3$
40. $f(x) = x^3 - x^2 - 2x + 2$
41. $f(x) = 2x^3 - x^2 - 8x + 4$
42. $f(x) = 3x^3 + x^2 - 48x - 16$

Determine whether the statement is true or false.

43. If $P(x) = (x - 3)^4(x + 1)^3$, then the graph of the polynomial function $y = P(x)$ crosses the x -axis at $(3, 0)$.
44. If $P(x) = (x + 2)^2\left(x - \frac{1}{4}\right)^5$, then the graph of the polynomial function $y = P(x)$ crosses the x -axis at $\left(\frac{1}{4}, 0\right)$.
45. If $P(x) = (x - 2)^3(x + 5)^6$, then the graph of $y = P(x)$ is tangent to the x -axis at $(-5, 0)$.
46. If $P(x) = (x + 4)^2(x - 1)^2$, then the graph of $y = P(x)$ is tangent to the x -axis at $(4, 0)$.
47. **Twin Births.** As a result of a greater number of births to older women and the increased use of fertility drugs, the number of twin births in the United States increased approximately 42% from 1990 to 2005 (Source: National Center for Health Statistics, U.S. Department of Health and Human Services). The quartic function

$$f(x) = -0.056316x^4 - 19.500154x^3 + 584.892054x^2 - 1518.5717x + 94,299.1990,$$

where x is the number of years since 1990, can be used to estimate the number of twin births from 1990 to 2006. Estimate the number of twin births in 1995 and in 2005.



48. **Railroad Miles.** The greatest combined length of U.S.-owned operating railroad track existed in 1916, when industrial activity increased during World War I. The total length has decreased ever since. The data over the years 1900 to 2008 are modeled by the quartic function

$$f(x) = -0.004091x^4 + 1.275179x^3 - 142.589291x^2 + 5069.1067x + 197,909.1675,$$

where x is the number of years since 1900 and $f(x)$ is in miles (Source: Association of American Railroads). Find the number of miles of operating railroad track in the United States in 1916, in 1960, and in 1985, and estimate the number in 2010. (Note: The lengths exclude yard tracks, sidings, and parallel tracks.)



49. **Dog Years.** A dog's life span is typically much shorter than that of a human. The cubic function

$$d(x) = 0.010255x^3 - 0.340119x^2 + 7.397499x + 6.618361,$$

where x is the dog's age, in years, approximates the equivalent human age in years. Estimate the equivalent human age for dogs that are 3, 12, and 16 years old.

50. **Threshold Weight.** In a study performed by Alvin Shemesh, it was found that the **threshold weight** W , defined as the weight above which the risk of death rises dramatically, is given by

$$W(h) = \left(\frac{h}{12.3}\right)^3,$$

where W is in pounds and h is a person's height, in inches. Find the threshold weight of a person who is 5 ft 7 in. tall.

51. **Projectile Motion.** A stone thrown downward with an initial velocity of 34.3 m/sec will travel a distance of s meters, where

$$s(t) = 4.9t^2 + 34.3t$$

and t is in seconds. If a stone is thrown downward at 34.3 m/sec from a height of 294 m, how long will it take the stone to hit the ground?

52. **Games in a Sports League.** If there are x teams in a sports league and all the teams play each other twice, a total of $N(x)$ games are played, where

$$N(x) = x^2 - x.$$

A softball league has 9 teams, each of which plays the others twice. If the league pays \$110 per game for the field and the umpires, how much will it cost to play the entire schedule?

53. **Median Home Prices.** The median price for an existing home in the United States peaked at \$221,900 in 2006 (Source: National Association of REALTORS®). The quartic function

$$h(x) = 56.8328x^4 - 1554.7494x^3 + 10,451.8211x^2 - 5655.7692x + 140,589.1608,$$

where x is the number of years since 2000, can be used to estimate the median existing-home price

from 2000 to 2009. Estimate the median existing-home price in 2002, in 2005, in 2008, and in 2009.



54. **Circulation of Daily Newspapers.** In 1985, the circulation of daily newspapers reached its highest level (Source: Newspaper Association of America). The quartic function

$$f(x) = -0.006093x^4 + 0.849362x^3 - 51.892087x^2 + 1627.3581x + 41,334.7289,$$

where x is the number of years since 1940, can be used to estimate the circulation of daily newspapers, in thousands, from 1940 to 2008. Using this function, estimate the circulation of daily newspapers in 1945, in 1985, and in 2008.

55. **Interest Compounded Annually.** When P dollars is invested at interest rate i , compounded annually, for t years, the investment grows to A dollars, where

$$A = P(1 + i)^t.$$

Trevor's parents deposit \$8000 in a savings account when Trevor is 16 years old. The principal plus interest is to be used for a truck when Trevor is 18 years old. Find the interest rate i if the \$8000 grows to \$9039.75 in 2 years.

56. **Interest Compounded Annually.** When P dollars is invested at interest rate i , compounded annually, for t years, the investment grows to A dollars, where

$$A = P(1 + i)^t.$$

When Sara enters the 11th grade, her grandparents deposit \$10,000 in a college savings account. Find the interest rate i if the \$10,000 grows to \$11,193.64 in 2 years.

Skill Maintenance

Find the distance between the pair of points.

57. $(3, -5)$ and $(0, -1)$

58. $(4, 2)$ and $(-2, -4)$

59. Find the center and the radius of the circle

$$(x - 3)^2 + (y + 5)^2 = 49.$$

60. The diameter of a circle connects the points $(-6, 5)$ and $(-2, 1)$ on the circle. Find the coordinates of the center of the circle and the length of the radius.

Solve.

61. $2y - 3 \geq 1 - y + 5$

62. $(x - 2)(x + 5) > x(x - 3)$

63. $|x + 6| \geq 7$

64. $|x + \frac{1}{4}| \leq \frac{2}{3}$

Synthesis

Determine the degree and the leading term of the polynomial function.

65. $f(x) = (x^5 - 1)^2(x^2 + 2)^3$

66. $f(x) = (10 - 3x^5)^2(5 - x^4)^3(x + 4)$

Graphing Polynomial Functions**4.2**

- ▶ Graph polynomial functions.
- ▶ Use the intermediate value theorem to determine whether a function has a real zero between two given real numbers.

▶ Graphing Polynomial Functions

In addition to using the leading-term test and finding the zeros of the function, it is helpful to consider the following facts when graphing a polynomial function.

Graph of a Polynomial Function

If $P(x)$ is a polynomial function of degree n , the graph of the function has:

- at most n real zeros, and thus at most n x -intercepts;
- at most $n - 1$ turning points.

(Turning points on a graph, also called relative maxima and minima, occur when the function changes from decreasing to increasing or from increasing to decreasing.)

EXAMPLE 1 Graph the polynomial function $h(x) = -2x^4 + 3x^3$.

Solution

1. First, we use the leading-term test to determine the end behavior of the graph. The leading term is $-2x^4$. The degree, 4, is even, and the coefficient, -2 , is negative. Thus the end behavior of the graph as $x \rightarrow \infty$ and as $x \rightarrow -\infty$ can be sketched as follows.



2. The zeros of the function are the first coordinates of the x -intercepts of the graph. To find the zeros, we solve $h(x) = 0$ by factoring and using the principle of zero products.

$$-2x^4 + 3x^3 = 0$$

$$-x^3(2x - 3) = 0$$

$$-x^3 = 0 \quad \text{or} \quad 2x - 3 = 0$$

$$x = 0 \quad \text{or} \quad x = \frac{3}{2}$$

Factoring

Using the principle of zero products

The zeros of the function are 0 and $\frac{3}{2}$. Note that the multiplicity of 0 is 3 and the multiplicity of $\frac{3}{2}$ is 1. The x -intercepts are $(0, 0)$ and $(\frac{3}{2}, 0)$.

3. The zeros divide the x -axis into three intervals:

$$(-\infty, 0), \quad \left(0, \frac{3}{2}\right), \quad \text{and} \quad \left(\frac{3}{2}, \infty\right).$$



The sign of $h(x)$ is the same for all values of x in each of the three intervals. That is, **$h(x)$ is positive for all x -values in an interval or $h(x)$ is negative for all x -values in an interval.** To determine which, we choose a test value for x from each interval and find $h(x)$.

Interval	$(-\infty, 0)$	$(0, \frac{3}{2})$	$(\frac{3}{2}, \infty)$
Test Value, x	-1	1	2
Function Value, $h(x)$	-5	1	-8
Sign of $h(x)$	$-$	$+$	$-$
Location of Points on Graph	Below x -axis	Above x -axis	Below x -axis

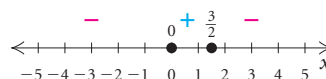

This test-point procedure also gives us three points to plot. In this case, we have $(-1, -5)$, $(1, 1)$, and $(2, -8)$.

4. To determine the y -intercept, we find $h(0)$:

$$h(x) = -2x^4 + 3x^3$$

$$h(0) = -2 \cdot 0^4 + 3 \cdot 0^3 = 0.$$

The y -intercept is $(0, 0)$.

5. A few additional points are helpful when completing the graph.

x	$h(x)$
-1.5	-20.25
-0.5	-0.5
0.5	0.25
2.5	-31.25

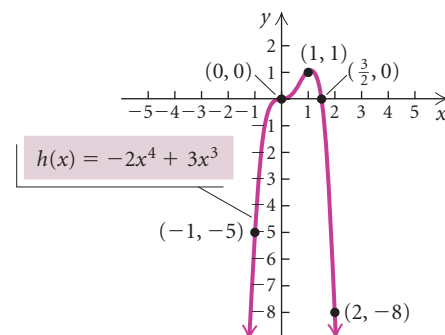

6. The degree of h is 4. The graph of h can have at most 4 x -intercepts and at most 3 turning points. In fact, it has 2 x -intercepts and 1 turning point. The zeros, 0 and $\frac{3}{2}$, each have odd multiplicities: 3 for 0 and 1 for $\frac{3}{2}$. Since the multiplicities are odd, the graph crosses the x -axis at 0 and $\frac{3}{2}$. The end behavior of the graph is what we described in step (1). As $x \rightarrow \infty$ and also as $x \rightarrow -\infty$, $h(x) \rightarrow -\infty$. The graph appears to be correct.

 **Now Try Exercise 23.**

The following is a procedure for graphing polynomial functions.

To graph a polynomial function:

1. Use the leading-term test to determine the end behavior.
2. Find the zeros of the function by solving $f(x) = 0$. Any real zeros are the first coordinates of the x -intercepts.
3. Use the x -intercepts (zeros) to divide the x -axis into intervals and choose a test point in each interval to determine the sign of all function values in that interval.
4. Find $f(0)$. This gives the y -intercept of the function.
5. If necessary, find additional function values to determine the general shape of the graph and then draw the graph.
6. As a partial check, use the facts that the graph has at most n x -intercepts and at most $n - 1$ turning points. Multiplicity of zeros can also be considered in order to check where the graph crosses or is tangent to the x -axis.

EXAMPLE 2 Graph the polynomial function

$$f(x) = 2x^3 + x^2 - 8x - 4.$$

Solution

1. The leading term is $2x^3$. The degree, 3, is odd, and the coefficient, 2, is positive. Thus the end behavior of the graph will appear as follows.



2. To find the zeros, we solve $f(x) = 0$. Here we can use factoring by grouping.

$$2x^3 + x^2 - 8x - 4 = 0$$

$$x^2(2x + 1) - 4(2x + 1) = 0 \quad \text{Factoring by grouping}$$

$$(2x + 1)(x^2 - 4) = 0$$

$$(2x + 1)(x + 2)(x - 2) = 0 \quad \text{Factoring a difference of squares}$$

The zeros are $-\frac{1}{2}$, -2 , and 2 . Each is of multiplicity 1. The x -intercepts are $(-2, 0)$, $(-\frac{1}{2}, 0)$, and $(2, 0)$.

3. The zeros divide the x -axis into four intervals:

$$(-\infty, -2), \quad \left(-2, -\frac{1}{2}\right), \quad \left(-\frac{1}{2}, 2\right), \quad \text{and} \quad (2, \infty).$$

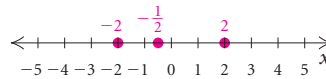

We choose a test value for x from each interval and find $f(x)$.

Interval	$(-\infty, -2)$	$(-2, -\frac{1}{2})$	$(-\frac{1}{2}, 2)$	$(2, \infty)$
Test Value, x	-3	-1	1	3
Function Value, $f(x)$	-25	3	-9	35
Sign of $f(x)$	$-$	$+$	$-$	$+$
Location of Points on Graph	Below x -axis	Above x -axis	Below x -axis	Above x -axis

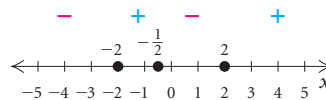

The test values and corresponding function values also give us four points on the graph: $(-3, -25)$, $(-1, 3)$, $(1, -9)$, and $(3, 35)$.

4. To determine the y -intercept, we find $f(0)$:

$$f(x) = 2x^3 + x^2 - 8x - 4$$

$$f(0) = 2 \cdot 0^3 + 0^2 - 8 \cdot 0 - 4 = -4.$$

The y -intercept is $(0, -4)$.

5. We find a few additional points and complete the graph.

x	$f(x)$
-2.5	-9
-1.5	3.5
0.5	-7.5
1.5	-7

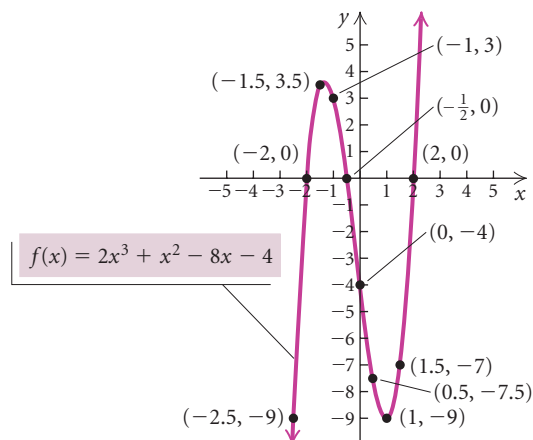

6. The degree of f is 3. The graph of f can have at most 3 x -intercepts and at most 2 turning points. It has 3 x -intercepts and 2 turning points. Each zero has a multiplicity of 1; thus the graph crosses the x -axis at -2 , $-\frac{1}{2}$, and 2 . The graph has the end behavior described in step (1). As $x \rightarrow -\infty$, $h(x) \rightarrow -\infty$, and as $x \rightarrow \infty$, $h(x) \rightarrow \infty$. The graph appears to be correct. ➔ **Now Try Exercise 33.**

Some polynomials are difficult to factor. In the next example, the polynomial is given in factored form. In Sections 4.3 and 4.4, we will learn methods that facilitate determining factors of such polynomials.

EXAMPLE 3 Graph the polynomial function

$$g(x) = x^4 - 7x^3 + 12x^2 + 4x - 16$$

$$= (x + 1)(x - 2)^2(x - 4).$$

Solution

1. The leading term is x^4 . The degree, 4, is even, and the coefficient, 1, is positive. The sketch below shows the end behavior.



2. To find the zeros, we solve $g(x) = 0$:

$$(x + 1)(x - 2)^2(x - 4) = 0.$$

The zeros are -1 , 2 , and 4 ; 2 is of multiplicity 2; the others are of multiplicity 1. The x -intercepts are $(-1, 0)$, $(2, 0)$, and $(4, 0)$.

3. The zeros divide the x -axis into four intervals:

$$(-\infty, -1), \quad (-1, 2), \quad (2, 4), \quad \text{and} \quad (4, \infty).$$



We choose a test value for x from each interval and find $g(x)$.

Interval	$(-\infty, -1)$	$(-1, 2)$	$(2, 4)$	$(4, \infty)$
Test Value, x	-1.25	1	3	4.25
Function Value, $g(x)$	≈ 13.9	-6	-4	≈ 6.6
Sign of $g(x)$	+	-	-	+
Location of Points on Graph	Above x -axis	Below x -axis	Below x -axis	Above x -axis

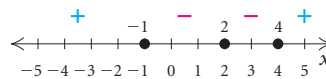

The test values and the corresponding function values also give us four points on the graph: $(-1.25, 13.9)$, $(1, -6)$, $(3, -4)$, and $(4.25, 6.6)$.

4. To determine the y -intercept, we find $g(0)$:

$$g(x) = x^4 - 7x^3 + 12x^2 + 4x - 16$$

$$g(0) = 0^4 - 7 \cdot 0^3 + 12 \cdot 0^2 + 4 \cdot 0 - 16 = -16.$$

The y -intercept is $(0, -16)$.

5. We find a few additional points and draw the graph.

x	$g(x)$
-0.5	-14.1
0.5	-11.8
1.5	-1.6
2.5	-1.3
3.5	-5.1

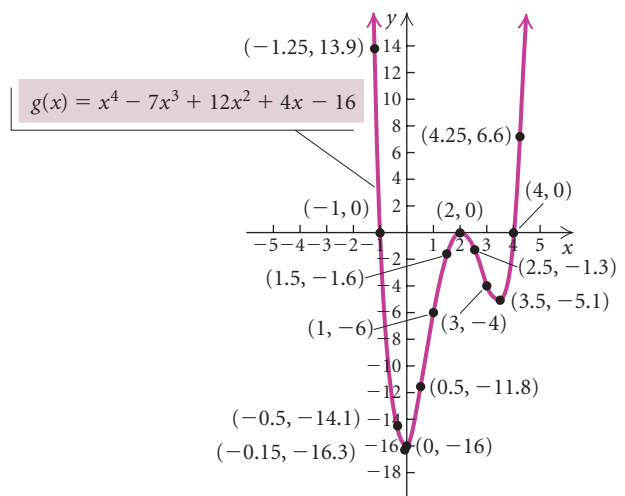

6. The degree of g is 4. The graph of g can have at most 4 x -intercepts and at most 3 turning points. It has 3 x -intercepts and 3 turning points. One of the zeros, 2, has a multiplicity of 2, so the graph is tangent to the x -axis at 2. The other zeros, -1 and 4, each have a multiplicity of 1 so the graph crosses the x -axis at -1 and 4. The graph has the end behavior described in step (1). As $x \rightarrow \infty$ and as $x \rightarrow -\infty$, $g(x) \rightarrow \infty$. The graph appears to be correct.

 **Now Try Exercise 19.**

► The Intermediate Value Theorem

Polynomial functions are continuous, hence their graphs are unbroken. The domain of a polynomial function, unless restricted by the statement of the function, is $(-\infty, \infty)$. Suppose two polynomial function values $P(a)$ and $P(b)$ have opposite signs. Since P is continuous, its graph must be a curve from $(a, P(a))$ to $(b, P(b))$ without a break. Then it follows that the curve must cross the x -axis at at least one point c between a and b ; that is, the function has a zero at c between a and b .

■ STUDY TIP

Visualization is one key to understanding and retaining new concepts. This text has an exceptional art package with precise color-coding to streamline the learning process. Take time to study each art piece and observe the concept that is illustrated.

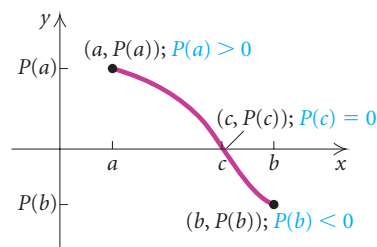

The Intermediate Value Theorem

For any polynomial function $P(x)$ with real coefficients, suppose that for $a \neq b$, $P(a)$ and $P(b)$ are of opposite signs. Then the function has at least one real zero between a and b .

The intermediate value theorem *cannot* be used to determine whether there is a real zero between a and b when $P(a)$ and $P(b)$ have the *same* sign.

EXAMPLE 4 Using the intermediate value theorem, determine, if possible, whether the function has at least one real zero between a and b .

- $f(x) = x^3 + x^2 - 6x$; $a = -4$, $b = -2$
- $f(x) = x^3 + x^2 - 6x$; $a = -1$, $b = 3$
- $g(x) = \frac{1}{3}x^4 - x^3$; $a = -\frac{1}{2}$, $b = \frac{1}{2}$
- $g(x) = \frac{1}{3}x^4 - x^3$; $a = 1$, $b = 2$

Solution We find $f(a)$ and $f(b)$ or $g(a)$ and $g(b)$ and determine whether they differ in sign. The graphs of $f(x)$ and $g(x)$ provide visual checks of the conclusions.

$$\begin{aligned} \text{a) } f(-4) &= (-4)^3 + (-4)^2 - 6(-4) = -24, \\ f(-2) &= (-2)^3 + (-2)^2 - 6(-2) = 8 \end{aligned}$$

Note that $f(-4)$ is negative and $f(-2)$ is positive. By the intermediate value theorem, since $f(-4)$ and $f(-2)$ have opposite signs, then $f(x)$ has at least one zero between -4 and -2 . The graph below confirms this.

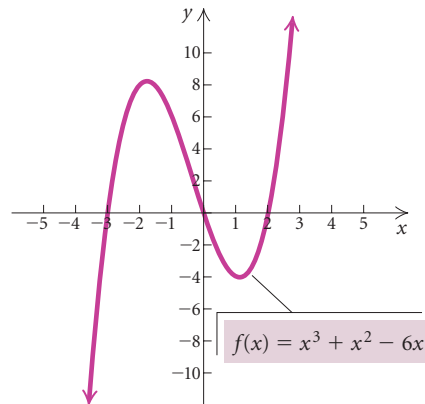

$$\begin{aligned} \text{b) } f(-1) &= (-1)^3 + (-1)^2 - 6(-1) = 6, \\ f(3) &= 3^3 + 3^2 - 6(3) = 18 \end{aligned}$$

Both $f(-1)$ and $f(3)$ are positive. Thus the intermediate value theorem *does not allow* us to determine whether there is a real zero between -1 and 3 . Note that the graph of $f(x)$ above shows that there are two zeros between -1 and 3 .

$$\begin{aligned} \text{c) } g\left(-\frac{1}{2}\right) &= \frac{1}{3}\left(-\frac{1}{2}\right)^4 - \left(-\frac{1}{2}\right)^3 = \frac{7}{48}, \\ g\left(\frac{1}{2}\right) &= \frac{1}{3}\left(\frac{1}{2}\right)^4 - \left(\frac{1}{2}\right)^3 = -\frac{5}{48} \end{aligned}$$

Since $g\left(-\frac{1}{2}\right)$ and $g\left(\frac{1}{2}\right)$ have opposite signs, $g(x)$ has at least one zero between $-\frac{1}{2}$ and $\frac{1}{2}$. The graph at left confirms this.

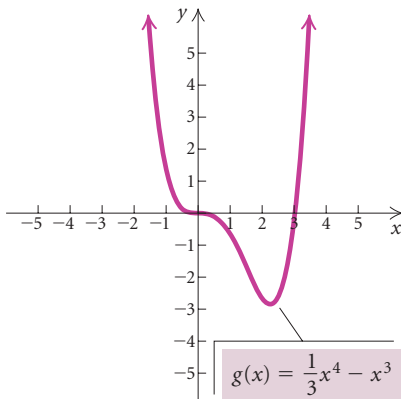

$$\begin{aligned} \text{d) } g(1) &= \frac{1}{3}(1)^4 - 1^3 = -\frac{2}{3}, \\ g(2) &= \frac{1}{3}(2)^4 - 2^3 = -\frac{8}{3} \end{aligned}$$

Both $g(1)$ and $g(2)$ are negative. Thus the intermediate value theorem *does not allow* us to determine whether there is a real zero between 1 and 2 . Note that the graph of $g(x)$ at left shows that there are no zeros between 1 and 2 .

➔ **Now Try Exercises 39 and 43.**

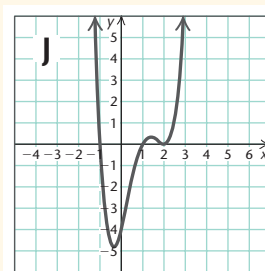
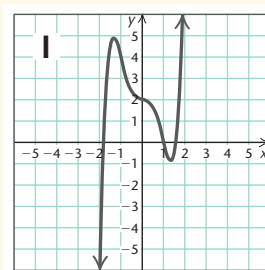
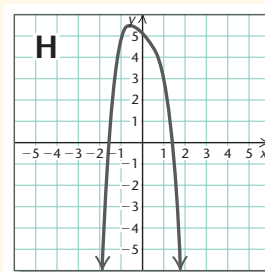
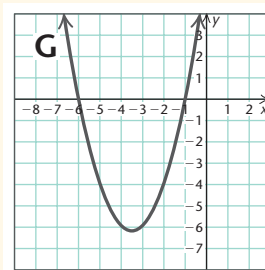
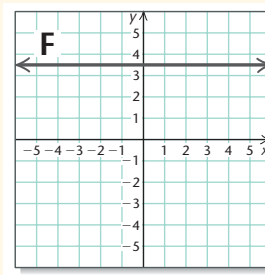
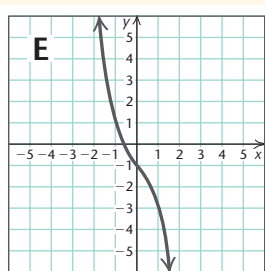
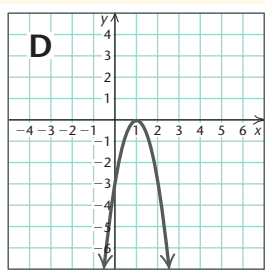
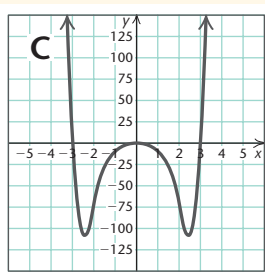
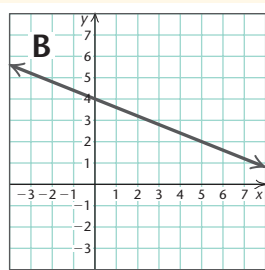
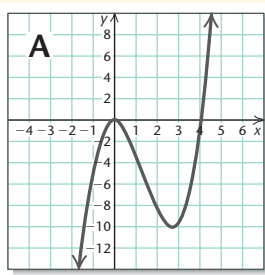

Visualizing the Graph

Match the function with its graph.

- $f(x) = -x^4 - x + 5$
- $f(x) = -3x^2 + 6x - 3$
- $f(x) = x^4 - 4x^3 + 3x^2 + 4x - 4$
- $f(x) = -\frac{2}{5}x + 4$
- $f(x) = x^3 - 4x^2$
- $f(x) = x^6 - 9x^4$
- $f(x) = x^5 - 3x^3 + 2$
- $f(x) = -x^3 - x - 1$
- $f(x) = x^2 + 7x + 6$
- $f(x) = \frac{7}{2}$

Answers on page A-20

4.2

Exercise Set

For each function in Exercises 1–6, state:

- the maximum number of real zeros that the function can have;
- the maximum number of x -intercepts that the graph of the function can have; and
- the maximum number of turning points that the graph of the function can have.

1. $f(x) = x^5 - x^2 + 6$

2. $f(x) = -x^2 + x^4 - x^6 + 3$

3. $f(x) = x^{10} - 2x^5 + 4x - 2$

4. $f(x) = \frac{1}{4}x^3 + 2x^2$

5. $f(x) = -x - x^3$

6. $f(x) = -3x^4 + 2x^3 - x - 4$

In Exercises 7–12, use the leading-term test and your knowledge of y -intercepts to match the function with one of the graphs (a)–(f), which follow.

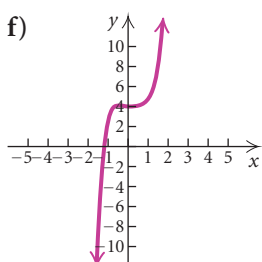
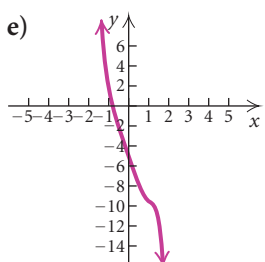
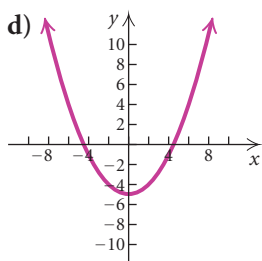
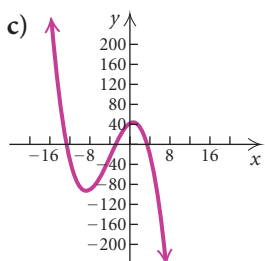
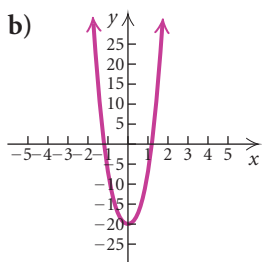
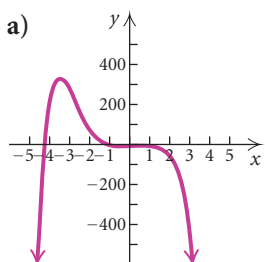

7. $f(x) = \frac{1}{4}x^2 - 5$

8. $f(x) = -0.5x^6 - x^5 + 4x^4 - 5x^3 - 7x^2 + x - 3$

9. $f(x) = x^5 - x^4 + x^2 + 4$

10. $f(x) = -\frac{1}{3}x^3 - 4x^2 + 6x + 42$

11. $f(x) = x^4 - 2x^3 + 12x^2 + x - 20$

12. $f(x) = -0.3x^7 + 0.11x^6 - 0.25x^5 + x^4 + x^3 - 6x - 5$

Graph the polynomial function. Follow the steps outlined in the procedure on p. 311.

13. $f(x) = -x^3 - 2x^2$

14. $g(x) = x^4 - 4x^3 + 3x^2$

15. $h(x) = x^2 + 2x - 3$

16. $f(x) = x^2 - 5x + 4$

17. $h(x) = x^5 - 4x^3$

18. $f(x) = x^3 - x$

19. $h(x) = x(x - 4)(x + 1)(x - 2)$

20. $f(x) = x(x - 1)(x + 3)(x + 5)$

21. $g(x) = -\frac{1}{4}x^3 - \frac{3}{4}x^2$

22. $f(x) = \frac{1}{2}x^3 + \frac{5}{2}x^2$

23. $g(x) = -x^4 - 2x^3$

24. $h(x) = x^3 - 3x^2$

25. $f(x) = -\frac{1}{2}(x - 2)(x + 1)^2(x - 1)$

26. $g(x) = (x - 2)^3(x + 3)$

27. $g(x) = -x(x - 1)^2(x + 4)^2$

28. $h(x) = -x(x - 3)(x - 3)(x + 2)$

29. $f(x) = (x - 2)^2(x + 1)^4$

30. $g(x) = x^4 - 9x^2$

31. $g(x) = -(x - 1)^4$

32. $h(x) = (x + 2)^3$

33. $h(x) = x^3 + 3x^2 - x - 3$

34. $g(x) = -x^3 + 2x^2 + 4x - 8$

35. $f(x) = 6x^3 - 8x^2 - 54x + 72$

36. $h(x) = x^5 - 5x^3 + 4x$

Graph each piecewise function.

37.
$$g(x) = \begin{cases} -x + 3, & \text{for } x \leq -2, \\ 4, & \text{for } -2 < x < 1, \\ \frac{1}{2}x^3, & \text{for } x \geq 1 \end{cases}$$

38.
$$h(x) = \begin{cases} -x^2, & \text{for } x < -2, \\ x + 1, & \text{for } -2 \leq x < 0, \\ x^3 - 1, & \text{for } x \geq 0 \end{cases}$$

Using the intermediate value theorem, determine, if possible, whether the function f has at least one real zero between a and b .

39. $f(x) = x^3 + 3x^2 - 9x - 13$; $a = -5, b = -4$

40. $f(x) = x^3 + 3x^2 - 9x - 13$; $a = 1, b = 2$

41. $f(x) = 3x^2 - 2x - 11$; $a = -3, b = -2$

42. $f(x) = 3x^2 - 2x - 11$; $a = 2, b = 3$

43. $f(x) = x^4 - 2x^2 - 6$; $a = 2, b = 3$

44. $f(x) = 2x^5 - 7x + 1$; $a = 1, b = 2$

45. $f(x) = x^3 - 5x^2 + 4$; $a = 4, b = 5$

46. $f(x) = x^4 - 3x^2 + x - 1$; $a = -3, b = -2$

Skill Maintenance

In Exercises 47–52, match the equation with one of the graphs (a)–(f), which follow.

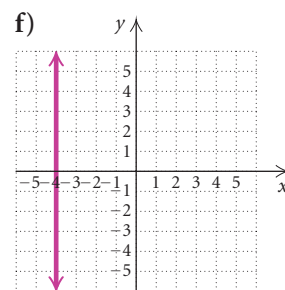
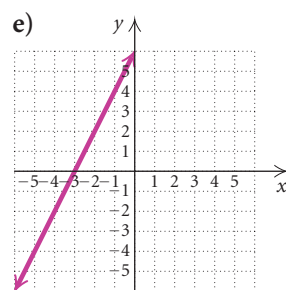
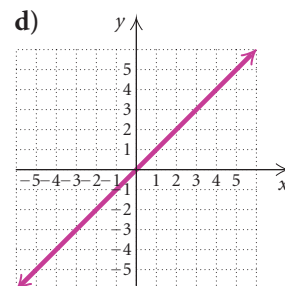
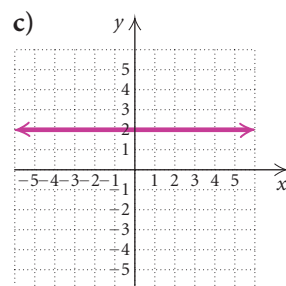
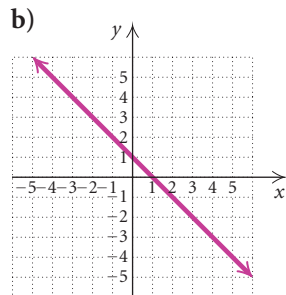
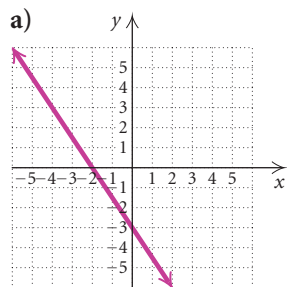

47. $y = x$

48. $x = -4$

49. $y - 2x = 6$

50. $3x + 2y = -6$

51. $y = 1 - x$

52. $y = 2$

Solve.

53. $2x - \frac{1}{2} = 4 - 3x$

54. $x^3 - x^2 - 12x = 0$

55. $6x^2 - 23x - 55 = 0$

56. $\frac{3}{4}x + 10 = \frac{1}{5} + 2x$

Polynomial Division; The Remainder Theorem and the Factor Theorem

4.3

- ▶ Perform long division with polynomials and determine whether one polynomial is a factor of another.
- ▶ Use synthetic division to divide a polynomial by $x - c$.
- ▶ Use the remainder theorem to find a function value $f(c)$.
- ▶ Use the factor theorem to determine whether $x - c$ is a factor of $f(x)$.

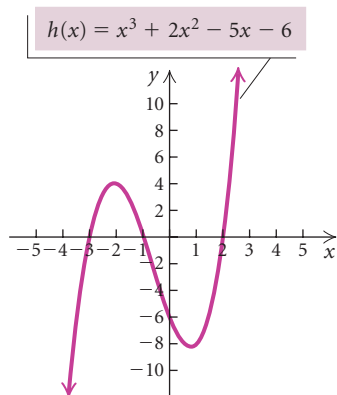

In general, finding exact zeros of many polynomial functions is neither easy nor straightforward. In this section and the one that follows, we develop concepts that help us find exact zeros of certain polynomial functions with degree 3 or greater.

Consider the polynomial

$$h(x) = x^3 + 2x^2 - 5x - 6 = (x + 3)(x + 1)(x - 2).$$

The factors are

$$x + 3, \quad x + 1, \quad \text{and} \quad x - 2,$$

and the zeros are

$$-3, \quad -1, \quad \text{and} \quad 2.$$

When a polynomial is expressed in factored form, each factor determines a zero of the function. Thus if we know the factors of a polynomial, we can easily find the zeros. The “reverse” is also true: If we know the zeros of a polynomial function, we can find the factors of the polynomial.

▶ Division and Factors

When we divide one polynomial by another, we obtain a quotient and a remainder. If the remainder is 0, then the divisor is a factor of the dividend.

EXAMPLE 1 Divide to determine whether $x + 1$ and $x - 3$ are factors of $x^3 + 2x^2 - 5x - 6$.

Solution We divide $x^3 + 2x^2 - 5x - 6$ by $x + 1$.

$$\begin{array}{r}
 \text{Quotient} \\
 \overline{x^2 + x - 6} \\
 x + 1 \overline{) x^3 + 2x^2 - 5x - 6} \leftarrow \text{Dividend} \\
 \underline{x^3 + x^2} \\
 x^2 - 5x \\
 \underline{x^2 + x} \\
 -6x - 6 \\
 \underline{-6x - 6} \\
 0 \leftarrow \text{Remainder}
 \end{array}$$

Divisor
↑
↑

Since the remainder is 0, we know that $x + 1$ is a factor of $x^3 + 2x^2 - 5x - 6$. In fact, we know that

$$x^3 + 2x^2 - 5x - 6 = (x + 1)(x^2 + x - 6).$$

We divide $x^3 + 2x^2 - 5x - 6$ by $x - 3$.

$$\begin{array}{r} x^2 + 5x + 10 \\ x - 3 \overline{) x^3 + 2x^2 - 5x - 6} \\ \underline{x^3 - 3x^2} \\ 5x^2 - 5x \\ \underline{5x^2 - 15x} \\ 10x - 6 \\ \underline{10x - 30} \\ 24 \end{array}$$

24 ← Remainder

Since the remainder is not 0, we know that $x - 3$ is *not* a factor of $x^3 + 2x^2 - 5x - 6$.

 **Now Try Exercise 3.**

STUDY TIP

The new mathematical skills and concepts presented in lectures will be of increased value to you if you begin the homework assignment as soon as possible after the lecture. Then if you still have difficulty with any of the exercises, you have time to access supplementary resources.

When we divide a polynomial $P(x)$ by a divisor $d(x)$, a polynomial $Q(x)$ is the quotient and a polynomial $R(x)$ is the remainder. The quotient $Q(x)$ must have degree less than that of the dividend $P(x)$. The remainder $R(x)$ must either be 0 or have degree less than that of the divisor $d(x)$.

As in arithmetic, to check a division, we multiply the quotient by the divisor and add the remainder, to see if we get the dividend. Thus these polynomials are related as follows:

$$P(x) = d(x) \cdot Q(x) + R(x)$$

Dividend
Divisor
Quotient
Remainder

For instance, if $P(x) = x^3 + 2x^2 - 5x - 6$ and $d(x) = x - 3$, as in Example 1, then $Q(x) = x^2 + 5x + 10$ and $R(x) = 24$, and

$$\begin{aligned} P(x) &= d(x) \cdot Q(x) + R(x) \\ x^3 + 2x^2 - 5x - 6 &= (x - 3) \cdot (x^2 + 5x + 10) + 24 \\ &= x^3 + 5x^2 + 10x - 3x^2 - 15x - 30 + 24 \\ &= x^3 + 2x^2 - 5x - 6. \end{aligned}$$

► The Remainder Theorem and Synthetic Division

Consider the function

$$h(x) = x^3 + 2x^2 - 5x - 6.$$

When we divided $h(x)$ by $x + 1$ and $x - 3$ in Example 1, the remainders were 0 and 24, respectively. Let's now find the function values $h(-1)$ and $h(3)$:

$$h(-1) = (-1)^3 + 2(-1)^2 - 5(-1) - 6 = 0;$$

$$h(3) = (3)^3 + 2(3)^2 - 5(3) - 6 = 24.$$

Note that the function values are the same as the remainders. This suggests the following theorem.

The Remainder Theorem

If a number c is substituted for x in the polynomial $f(x)$, then the result $f(c)$ is the remainder that would be obtained by dividing $f(x)$ by $x - c$. That is, if $f(x) = (x - c) \cdot Q(x) + R$, then $f(c) = R$.

Proof (Optional) The equation $f(x) = d(x) \cdot Q(x) + R(x)$, where $d(x) = x - c$, is the basis of this proof. If we divide $f(x)$ by $x - c$, we obtain a quotient $Q(x)$ and a remainder $R(x)$ related as follows:

$$f(x) = (x - c) \cdot Q(x) + R(x).$$

The remainder $R(x)$ must either be 0 or have degree less than $x - c$. Thus, $R(x)$ must be a constant. Let's call this constant R . The equation above is true for any replacement of x , so we replace x with c . We get

$$\begin{aligned} f(c) &= (c - c) \cdot Q(c) + R \\ &= 0 \cdot Q(c) + R \\ &= R. \end{aligned}$$

Thus the function value $f(c)$ is the remainder obtained when we divide $f(x)$ by $x - c$. ■

The remainder theorem motivates us to find a rapid way of dividing by $x - c$ in order to find function values. To streamline division, we can arrange the work so that duplicate and unnecessary writing is avoided. Consider the following:

$$(4x^3 - 3x^2 + x + 7) \div (x - 2).$$

A.

$$\begin{array}{r} 4x^2 + 5x + 11 \\ x - 2 \overline{) 4x^3 - 3x^2 + x + 7} \\ \underline{4x^3 - 8x^2} \\ 5x^2 + x \\ \underline{5x^2 - 10x} \\ 11x + 7 \\ \underline{11x - 22} \\ 29 \end{array}$$

B.

$$\begin{array}{r} 4 \quad 5 \quad 11 \\ 1 - 2 \overline{) 4 - 3 + 1 + 7} \\ \underline{4 - 8} \\ 5 + 1 \\ \underline{5 - 10} \\ 11 + 7 \\ \underline{11 - 22} \\ 29 \end{array}$$

The division in (B) is the same as that in (A), but we wrote only the coefficients. The red numerals are duplicated, so we look for an arrangement in which they are not duplicated. In place of the divisor in the form $x - c$, we can simply use c and then add rather than subtract. When the procedure is “collapsed,” we have the algorithm known as **synthetic division**.

C. Synthetic Division

$$\begin{array}{r|rrrr} 2 & 4 & -3 & 1 & 7 \\ & \downarrow & \nearrow & \downarrow & \nearrow & \downarrow & \nearrow \\ & & 8 & 10 & 22 & & \\ \hline & 4 & & 5 & & 11 & & 29 \end{array}$$

The divisor is $x - 2$; thus we use 2 in synthetic division.

We “bring down” the 4. Then we multiply it by the 2 to get 8 and add to get 5. We then multiply 5 by 2 to get 10, add, and so on. The last number, 29, is the remainder. The others, 4, 5, and 11, are the coefficients of the quotient, $4x^2 + 5x + 11$. (Note that the degree of the quotient is 1 less than the degree of the dividend when the degree of the divisor is 1.)

When using synthetic division, we write a 0 for a missing term in the dividend.

EXAMPLE 2 Use synthetic division to find the quotient and the remainder:

$$(2x^3 + 7x^2 - 5) \div (x + 3).$$

Solution First, we note that $x + 3 = x - (-3)$.

$$\begin{array}{r|rrrr} -3 & 2 & 7 & 0 & -5 \\ & & -6 & -3 & 9 \\ \hline & 2 & 1 & -3 & 4 \end{array}$$

Note: We must write a 0 for the missing x -term.

The quotient is $2x^2 + x - 3$. The remainder is 4.

 **Now Try Exercise 11.**

We can now use synthetic division to find polynomial function values.

EXAMPLE 3 Given that $f(x) = 2x^5 - 3x^4 + x^3 - 2x^2 + x - 8$, find $f(10)$.

Solution By the remainder theorem, $f(10)$ is the remainder when $f(x)$ is divided by $x - 10$. We use synthetic division to find that remainder.

$$\begin{array}{r|rrrrrr} 10 & 2 & -3 & 1 & -2 & 1 & -8 \\ & & 20 & 170 & 1710 & 17,080 & 170,810 \\ \hline & 2 & 17 & 171 & 1708 & 17,081 & 170,802 \end{array}$$

Thus, $f(10) = 170,802$.

 **Now Try Exercise 25.**

Compare the computations in Example 3 with those in a direct substitution:

$$\begin{aligned} f(10) &= 2(10)^5 - 3(10)^4 + (10)^3 - 2(10)^2 + 10 - 8 \\ &= 2 \cdot 100,000 - 3 \cdot 10,000 + 1000 - 2 \cdot 100 + 10 - 8 \\ &= 200,000 - 30,000 + 1000 - 200 + 10 - 8 \\ &= 170,802. \end{aligned}$$

EXAMPLE 4 Determine whether 5 is a zero of $g(x)$, where

$$g(x) = x^4 - 26x^2 + 25.$$

Solution We use synthetic division and the remainder theorem to find $g(5)$.

$$\begin{array}{r|rrrr} 5 & 1 & 0 & -26 & 0 & 25 \\ & & 5 & 25 & -5 & -25 \\ \hline & 1 & 5 & -1 & -5 & 0 \end{array}$$

Writing 0's for missing terms:
 $x^4 + 0x^3 - 26x^2 + 0x + 25$

Since $g(5) = 0$, the number 5 is a zero of $g(x)$.

 **Now Try Exercise 31.**

TECHNOLOGY CONNECTION

The computations in synthetic division are less complicated than those involved in substituting. In Example 3, the easiest way to find $f(10)$ is to use one of the methods for evaluating a function on a graphing calculator. We enter $y_1 = 2x^5 - 3x^4 + x^3 - 2x^2 + x - 8$ and then use function notation on the home screen.

$Y_1(10)$

170802

EXAMPLE 5 Determine whether i is a zero of $f(x)$, where

$$f(x) = x^3 - 3x^2 + x - 3.$$

Solution We use synthetic division and the remainder theorem to find $f(i)$.

$$\begin{array}{r|rrrr} i & 1 & -3 & 1 & -3 \\ & & i & -3i - 1 & 3 \\ \hline & 1 & -3 + i & -3i & 0 \end{array}$$

$i(-3 + i) = -3i + i^2 = -3i - 1$
 $i(-3i) = -3i^2 = 3$

Since $f(i) = 0$, the number i is a zero of $f(x)$.

Now Try Exercise 35.

► Finding Factors of Polynomials

We now consider a useful result that follows from the remainder theorem.

The Factor Theorem

For a polynomial $f(x)$, if $f(c) = 0$, then $x - c$ is a factor of $f(x)$.

Proof (Optional) If we divide $f(x)$ by $x - c$, we obtain a quotient and a remainder, related as follows:

$$f(x) = (x - c) \cdot Q(x) + f(c).$$

Then if $f(c) = 0$, we have

$$f(x) = (x - c) \cdot Q(x),$$

so $x - c$ is a factor of $f(x)$. ■

The factor theorem is very useful in factoring polynomials and hence in solving polynomial equations and finding zeros of polynomial functions. If we know a zero of a polynomial function, we know a factor.

EXAMPLE 6 Let $f(x) = x^3 - 3x^2 - 6x + 8$. Factor $f(x)$ and solve the equation $f(x) = 0$.

Solution We look for linear factors of the form $x - c$. Let's try $x + 1$, or $x - (-1)$. (In the next section, we will learn a method for choosing the numbers to try for c .) We use synthetic division to determine whether $f(-1) = 0$.

$$\begin{array}{r|rrrr} -1 & 1 & -3 & -6 & 8 \\ & & -1 & 4 & 2 \\ \hline & 1 & -4 & -2 & 10 \end{array}$$

Since $f(-1) \neq 0$, we know that $x + 1$ is *not* a factor of $f(x)$. We now try $x - 1$.

$$\begin{array}{r|rrrr} 1 & 1 & -3 & -6 & 8 \\ & & 1 & -2 & -8 \\ \hline & 1 & -2 & -8 & 0 \end{array}$$

TECHNOLOGY CONNECTION

In Example 6, we can use a table set in ASK mode to check the solutions of the equation

$$x^3 - 3x^2 - 6x + 8 = 0.$$

We check the solutions, -2 , 1 , and 4 , of $f(x) = 0$ by evaluating $f(-2)$, $f(1)$, and $f(4)$.

X	Y1	
-2	0	
1	0	
4	0	
X =		

Since $f(1) = 0$, we know that $x - 1$ is *one factor* of $f(x)$ and the quotient, $x^2 - 2x - 8$, is another. Thus,

$$f(x) = (x - 1)(x^2 - 2x - 8).$$

The trinomial $x^2 - 2x - 8$ is easily factored in this case, so we have

$$f(x) = (x - 1)(x - 4)(x + 2).$$

Our goal is to solve the equation $f(x) = 0$. To do so, we use the principle of zero products:

$$(x - 1)(x - 4)(x + 2) = 0$$

$$x - 1 = 0 \quad \text{or} \quad x - 4 = 0 \quad \text{or} \quad x + 2 = 0$$

$$x = 1 \quad \text{or} \quad x = 4 \quad \text{or} \quad x = -2.$$

The solutions of the equation $x^3 - 3x^2 - 6x + 8 = 0$ are -2 , 1 , and 4 . They are also the zeros of the function $f(x) = x^3 - 3x^2 - 6x + 8$.

 **Now Try Exercise 41.**

CONNECTING THE CONCEPTS

$$y = x^3 + 2x^2 - 5x - 6$$

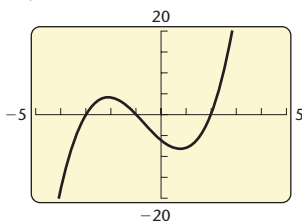

Consider the function

$$f(x) = (x - 2)(x + 3)(x + 1), \quad \text{or} \quad f(x) = x^3 + 2x^2 - 5x - 6,$$

and its graph.

We can make the following statements:

- -3 is a zero of f .
- $f(-3) = 0$.
- -3 is a solution of $f(x) = 0$.
- $(-3, 0)$ is an x -intercept of the graph of f .
- 0 is the remainder when $f(x)$ is divided by $x - (-3)$.
- $x - (-3)$ is a factor of f .

Similar statements are also true for -1 and 2 .

4.3 Exercise Set

1. For the function

$$f(x) = x^4 - 6x^3 + x^2 + 24x - 20,$$

use long division to determine whether each of the following is a factor of $f(x)$.

a) $x + 1$ b) $x - 2$ c) $x + 5$

2. For the function

$$h(x) = x^3 - x^2 - 17x - 15,$$

use long division to determine whether each of the following is a factor of $h(x)$.

a) $x + 5$ b) $x + 1$ c) $x + 3$

3. For the function

$$g(x) = x^3 - 2x^2 - 11x + 12,$$

use long division to determine whether each of the following is a factor of $g(x)$.

a) $x - 4$ b) $x - 3$ c) $x - 1$

4. For the function

$$f(x) = x^4 + 8x^3 + 5x^2 - 38x + 24,$$

use long division to determine whether each of the following is a factor of $f(x)$.

a) $x + 6$ b) $x + 1$ c) $x - 4$

In each of the following, a polynomial $P(x)$ and a divisor $d(x)$ are given. Use long division to find the quotient $Q(x)$ and the remainder $R(x)$ when $P(x)$ is divided by $d(x)$. Express $P(x)$ in the form $d(x) \cdot Q(x) + R(x)$.

5. $P(x) = x^3 - 8,$

$d(x) = x + 2$

6. $P(x) = 2x^3 - 3x^2 + x - 1,$

$d(x) = x - 3$

7. $P(x) = x^3 + 6x^2 - 25x + 18,$

$d(x) = x + 9$

8. $P(x) = x^3 - 9x^2 + 15x + 25,$

$d(x) = x - 5$

9. $P(x) = x^4 - 2x^2 + 3,$

$d(x) = x + 2$

10. $P(x) = x^4 + 6x^3,$

$d(x) = x - 1$

Use synthetic division to find the quotient and the remainder.

11. $(2x^4 + 7x^3 + x - 12) \div (x + 3)$

12. $(x^3 - 7x^2 + 13x + 3) \div (x - 2)$

13. $(x^3 - 2x^2 - 8) \div (x + 2)$

14. $(x^3 - 3x + 10) \div (x - 2)$

15. $(3x^3 - x^2 + 4x - 10) \div (x + 1)$

16. $(4x^4 - 2x + 5) \div (x + 3)$

17. $(x^5 + x^3 - x) \div (x - 3)$

18. $(x^7 - x^6 + x^5 - x^4 + 2) \div (x + 1)$

19. $(x^4 - 1) \div (x - 1)$

20. $(x^5 + 32) \div (x + 2)$

21. $(2x^4 + 3x^2 - 1) \div (x - \frac{1}{2})$

22. $(3x^4 - 2x^2 + 2) \div (x - \frac{1}{4})$

Use synthetic division to find the function values. Then check your work using a graphing calculator.

23. $f(x) = x^3 - 6x^2 + 11x - 6$; find $f(1), f(-2)$, and $f(3)$.

24. $f(x) = x^3 + 7x^2 - 12x - 3$; find $f(-3), f(-2)$, and $f(1)$.

25. $f(x) = x^4 - 3x^3 + 2x + 8$; find $f(-1), f(4)$, and $f(-5)$.

26. $f(x) = 2x^4 + x^2 - 10x + 1$; find $f(-10), f(2)$, and $f(3)$.

27. $f(x) = 2x^5 - 3x^4 + 2x^3 - x + 8$; find $f(20)$ and $f(-3)$.

28. $f(x) = x^5 - 10x^4 + 20x^3 - 5x - 100$; find $f(-10)$ and $f(5)$.

29. $f(x) = x^4 - 16$; find $f(2), f(-2), f(3)$, and $f(1 - \sqrt{2})$.

30. $f(x) = x^5 + 32$; find $f(2), f(-2), f(3)$, and $f(2 + 3i)$.

Using synthetic division, determine whether the numbers are zeros of the polynomial function.

31. $-3, 2$; $f(x) = 3x^3 + 5x^2 - 6x + 18$
 32. $-4, 2$; $f(x) = 3x^3 + 11x^2 - 2x + 8$
 33. $-3, 1$; $h(x) = x^4 + 4x^3 + 2x^2 - 4x - 3$
 34. $2, -1$; $g(x) = x^4 - 6x^3 + x^2 + 24x - 20$
 35. $i, -2i$; $g(x) = x^3 - 4x^2 + 4x - 16$
 36. $\frac{1}{3}, 2$; $h(x) = x^3 - x^2 - \frac{1}{9}x + \frac{1}{9}$
 37. $-3, \frac{1}{2}$; $f(x) = x^3 - \frac{7}{2}x^2 + x - \frac{3}{2}$
 38. $i, -i, -2$; $f(x) = x^3 + 2x^2 + x + 2$

Factor the polynomial function $f(x)$. Then solve the equation $f(x) = 0$.

39. $f(x) = x^3 + 4x^2 + x - 6$
 40. $f(x) = x^3 + 5x^2 - 2x - 24$
 41. $f(x) = x^3 - 6x^2 + 3x + 10$
 42. $f(x) = x^3 + 2x^2 - 13x + 10$
 43. $f(x) = x^3 - x^2 - 14x + 24$
 44. $f(x) = x^3 - 3x^2 - 10x + 24$
 45. $f(x) = x^4 - 7x^3 + 9x^2 + 27x - 54$
 46. $f(x) = x^4 - 4x^3 - 7x^2 + 34x - 24$
 47. $f(x) = x^4 - x^3 - 19x^2 + 49x - 30$
 48. $f(x) = x^4 + 11x^3 + 41x^2 + 61x + 30$

Sketch the graph of the polynomial function. Follow the procedure outlined on p. 311. Use synthetic division and the remainder theorem to find the zeros.

49. $f(x) = x^4 - x^3 - 7x^2 + x + 6$
 50. $f(x) = x^4 + x^3 - 3x^2 - 5x - 2$
 51. $f(x) = x^3 - 7x + 6$
 52. $f(x) = x^3 - 12x + 16$
 53. $f(x) = -x^3 + 3x^2 + 6x - 8$
 54. $f(x) = -x^4 + 2x^3 + 3x^2 - 4x - 4$

Skill Maintenance

Solve. Find exact solutions.

55. $2x^2 + 12 = 5x$
 56. $7x^2 + 4x = 3$

Consider the function

$$g(x) = x^2 + 5x - 14$$

in Exercises 57–59.

57. What are the inputs if the output is -14 ?
 58. What is the output if the input is 3 ?
 59. Given an output of -20 , find the corresponding inputs.
 60. **Movie Ticket Price.** The average price of a movie ticket has increased linearly over the years, rising from $\$2.69$ in 1980 to $\$7.18$ in 2008 (Source: Motion Picture Association of America). Using these two data points, find a linear function, $f(x) = mx + b$, that models the data. Let x represent the number of years since 1980. Then use this function to estimate the average price of a movie ticket in 1998 and in 2012.
 61. The sum of the base and the height of a triangle is 30 in. Find the dimensions for which the area is a maximum.

Synthesis

In Exercises 62 and 63, a graph of a polynomial function is given. On the basis of the graph:

- a) Find as many factors of the polynomial as you can.
 b) Construct a polynomial function with the zeros shown in the graph.
 c) Can you find any other polynomial functions with the given zeros?
 d) Can you find any other polynomial functions with the given zeros and the same graph?

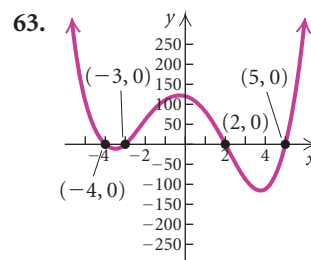
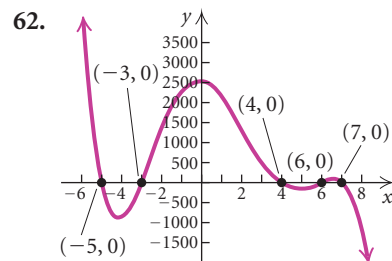

64. For what values of k will the remainder be the same when $x^2 + kx + 4$ is divided by $x - 1$ and by $x + 1$?
65. Find k such that $x + 2$ is a factor of $x^3 - kx^2 + 3x + 7k$.
66. **Beam Deflection.** A beam rests at two points A and B and has a concentrated load applied to its center, as shown below. Let $y =$ the deflection, in feet, of the beam at a distance of x feet from A . Under certain conditions, this deflection is given by

$$y = \frac{1}{13}x^3 - \frac{1}{14}x.$$

Find the zeros of the polynomial in the interval $[0, 2]$.

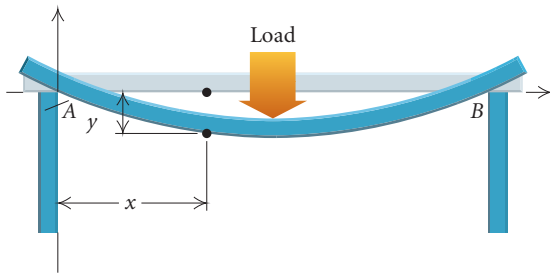

Solve.

67. $\frac{2x^2}{x^2 - 1} + \frac{4}{x + 3} = \frac{12x - 4}{x^3 + 3x^2 - x - 3}$
68. $\frac{6x^2}{x^2 + 11} + \frac{60}{x^3 - 7x^2 + 11x - 77} = \frac{1}{x - 7}$
69. Find a 15th-degree polynomial for which $x - 1$ is a factor. Answers may vary.

Use synthetic division to divide.

70. $(x^4 - y^4) \div (x - y)$
71. $(x^3 + 3ix^2 - 4ix - 2) \div (x + i)$
72. $(x^2 - 4x - 2) \div [x - (3 + 2i)]$
73. $(x^2 - 3x + 7) \div (x - i)$

Mid-Chapter Mixed Review

Determine whether the statement is true or false.

- The y -intercept of the graph of the function $P(x) = 5 - 2x^3$ is $(5, 0)$. [4.2]
- The degree of the polynomial $x - \frac{1}{2}x^4 - 3x^6 + x^5$ is 6. [4.1]
- If $f(x) = (x + 7)(x - 8)$, then $f(8) = 0$. [4.3]
- If $f(12) = 0$, then $x + 12$ is a factor of $f(x)$. [4.3]

Find the zeros of the polynomial function and state the multiplicity of each. [4.1]

- $f(x) = (x^2 - 10x + 25)^3$
- $h(x) = 2x^3 + x^2 - 50x - 25$
- $g(x) = x^4 - 3x^2 + 2$
- $f(x) = -6(x - 3)^2(x + 4)$

In Exercises 9–12, match the function with one of the graphs (a)–(d), which follow. [4.2]

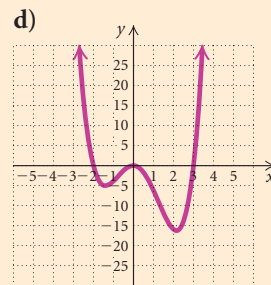
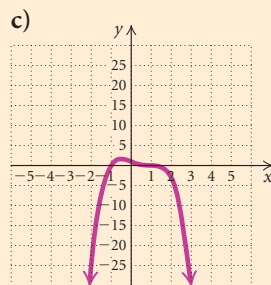
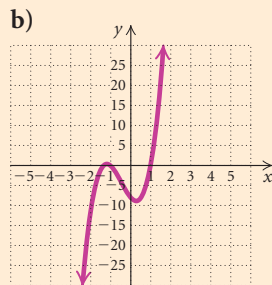
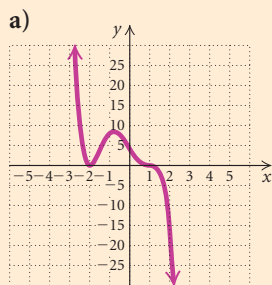

9. $f(x) = x^4 - x^3 - 6x^2$

11. $f(x) = 6x^3 + 8x^2 - 6x - 8$

10. $f(x) = -(x - 1)^3(x + 2)^2$

12. $f(x) = -(x - 1)^3(x + 1)$

Using the intermediate value theorem, determine, if possible, whether the function has at least one real zero between a and b . [4.2]

13. $f(x) = x^3 - 2x^2 + 3$; $a = -2$, $b = 0$

14. $f(x) = x^3 - 2x^2 + 3$; $a = -\frac{1}{2}$, $b = 1$

15. For the polynomial $P(x) = x^4 - 6x^3 + x - 2$ and the divisor $d(x) = x - 1$, use long division to find the quotient $Q(x)$ and the remainder $R(x)$ when $P(x)$ is divided by $d(x)$. Express $P(x)$ in the form $d(x) \cdot Q(x) + R(x)$. [4.3]

Use synthetic division to find the quotient and the remainder. [4.3]

16. $(3x^4 - x^3 + 2x^2 - 6x + 6) \div (x - 2)$

17. $(x^5 - 5) \div (x + 1)$

Use synthetic division to find the function values. [4.3]

18. $g(x) = x^3 - 9x^2 + 4x - 10$; find $g(-5)$

19. $f(x) = 20x^2 - 40x$; find $f(\frac{1}{2})$

20. $f(x) = 5x^4 + x^3 - x$; find $f(-\sqrt{2})$

Using synthetic division, determine whether the numbers are zeros of the polynomial function. [4.3]

21. $-3i, 3$; $f(x) = x^3 - 4x^2 + 9x - 36$

22. $-1, 5$; $f(x) = x^6 - 35x^4 + 259x^2 - 225$

Factor the polynomial function $f(x)$. Then solve the equation $f(x) = 0$. [4.3]

23. $h(x) = x^3 - 2x^2 - 55x + 56$

24. $g(x) = x^4 - 2x^3 - 13x^2 + 14x + 24$

Collaborative Discussion and Writing

25. How is the range of a polynomial function related to the degree of the polynomial? [4.1]

26. Is it possible for the graph of a polynomial function to have no y -intercept? no x -intercepts? Explain your answer. [4.2]

27. Explain why values of a function must be all positive or all negative between consecutive zeros. [4.2]

28. In synthetic division, why is the degree of the quotient 1 less than that of the dividend? [4.3]

Theorems about Zeros of Polynomial Functions

4.4

- ▶ Find a polynomial with specified zeros.
- ▶ For a polynomial function with integer coefficients, find the rational zeros and the other zeros, if possible.
- ▶ Use Descartes' rule of signs to find information about the number of real zeros of a polynomial function with real coefficients.

We will now allow the coefficients of a polynomial to be complex numbers. In certain cases, we will restrict the coefficients to be real numbers, rational numbers, or integers, as shown in the following examples.

Polynomial	Type of Coefficient
$5x^3 - 3x^2 + (2 + 4i)x + i$	Complex
$5x^3 - 3x^2 + \sqrt{2}x - \pi$	Real
$5x^3 - 3x^2 + \frac{2}{3}x - \frac{7}{4}$	Rational
$5x^3 - 3x^2 + 8x - 11$	Integer

▶ The Fundamental Theorem of Algebra

A linear, or first-degree, polynomial function $f(x) = mx + b$ (where $m \neq 0$) has just one zero, $-b/m$. It can be shown that any quadratic polynomial function $f(x) = ax^2 + bx + c$ with complex numbers for coefficients has at least one, and at most two, complex zeros. The following theorem is a generalization. No proof is given in this text.

The Fundamental Theorem of Algebra

Every polynomial function of degree n , with $n \geq 1$, has at least one zero in the set of complex numbers.

Note that although the fundamental theorem of algebra guarantees that a zero exists, it does not tell how to find it. Recall that the zeros of a polynomial function $f(x)$ are the solutions of the polynomial equation $f(x) = 0$. We now develop some concepts that can help in finding zeros. First, we consider one of the results of the fundamental theorem of algebra.

Every polynomial function f of degree n , with $n \geq 1$, can be factored into n linear factors (not necessarily unique); that is,

$$f(x) = a_n(x - c_1)(x - c_2) \cdots (x - c_n).$$

► Finding Polynomials with Given Zeros

Given several numbers, we can find a polynomial function with those numbers as its zeros.

EXAMPLE 1 Find a polynomial function of degree 3, having the zeros 1, $3i$, and $-3i$.

Solution Such a function has factors $x - 1$, $x - 3i$, and $x - (-3i)$, or $x + 3i$, so we have

$$f(x) = a_n(x - 1)(x - 3i)(x + 3i).$$

The number a_n can be any nonzero number. The simplest polynomial function will be obtained if we let it be 1. If we then multiply the factors, we obtain

$$\begin{aligned} f(x) &= (x - 1)(x^2 - 9i^2) && \text{Multiplying } (x - 3i)(x + 3i) \\ &= (x - 1)(x^2 + 9) && -9i^2 = -9(-1) = 9 \\ &= x^3 - x^2 + 9x - 9. \end{aligned}$$

➔ Now Try Exercise 3.

EXAMPLE 2 Find a polynomial function of degree 5 with -1 as a zero of multiplicity 3, 4 as a zero of multiplicity 1, and 0 as a zero of multiplicity 1.

Solution Proceeding as in Example 1, letting $a_n = 1$, we obtain

$$\begin{aligned} f(x) &= [x - (-1)]^3(x - 4)(x - 0) \\ &= (x + 1)^3(x - 4)x \\ &= (x^3 + 3x^2 + 3x + 1)(x^2 - 4x) \\ &= x^5 - x^4 - 9x^3 - 11x^2 - 4x. \end{aligned}$$

➔ Now Try Exercise 13.

► Zeros of Polynomial Functions with Real Coefficients

Consider the quadratic equation $x^2 - 2x + 2 = 0$, with real coefficients. Its solutions are $1 + i$ and $1 - i$. Note that they are complex conjugates. This generalizes to any polynomial equation with real coefficients.

Nonreal Zeros: $a + bi$ and $a - bi$, $b \neq 0$

If a complex number $a + bi$, $b \neq 0$, is a zero of a polynomial function $f(x)$ with real coefficients, then its conjugate, $a - bi$, is also a zero. For example, if $2 + 7i$ is a zero of a polynomial function $f(x)$, with real coefficients, then its conjugate, $2 - 7i$, is also a zero. (Nonreal zeros occur in conjugate pairs.)

In order for the preceding to be true, it is essential that the coefficients be real numbers.

► Rational Coefficients

When a polynomial function has *rational* numbers for coefficients, certain irrational zeros also occur in pairs, as described in the following theorem.

Irrational Zeros: $a + c\sqrt{b}$ and $a - c\sqrt{b}$, b is not a perfect square

If $a + c\sqrt{b}$, where a , b , and c are rational and b is not a perfect square, is a zero of a polynomial function $f(x)$ with *rational* coefficients, then its conjugate, $a - c\sqrt{b}$, is also a zero. For example, if $-3 + 5\sqrt{2}$ is a zero of a polynomial function $f(x)$ with rational coefficients, then its conjugate, $-3 - 5\sqrt{2}$, is also a zero. (Irrational zeros occur in conjugate pairs.)

EXAMPLE 3 Suppose that a polynomial function of degree 6 with rational coefficients has

$$-2 + 5i, \quad -2i, \quad \text{and} \quad 1 - \sqrt{3}$$

as three of its zeros. Find the other zeros.

Solution Since the coefficients are rational, and thus real, the other zeros are the conjugates of the given zeros:

$$-2 - 5i, \quad 2i, \quad \text{and} \quad 1 + \sqrt{3}.$$

There are no other zeros because a polynomial function of degree 6 can have at most 6 zeros.

► Now Try Exercise 17.

EXAMPLE 4 Find a polynomial function of lowest degree with rational coefficients that has $-\sqrt{3}$ and $1 + i$ as two of its zeros.

Solution The function must also have the zeros $\sqrt{3}$ and $1 - i$. Because we want to find the polynomial function of lowest degree with the given zeros, we will not include additional zeros; that is, we will write a polynomial function of degree 4. Thus if we let $a_n = 1$, the polynomial function is

$$\begin{aligned} f(x) &= [x - (-\sqrt{3})][x - \sqrt{3}][x - (1 + i)][x - (1 - i)] \\ &= (x + \sqrt{3})(x - \sqrt{3})[(x - 1) - i][(x - 1) + i] \\ &= (x^2 - 3)[(x - 1)^2 - i^2] \\ &= (x^2 - 3)[x^2 - 2x + 1 + 1] \\ &= (x^2 - 3)(x^2 - 2x + 2) \\ &= x^4 - 2x^3 - x^2 + 6x - 6. \end{aligned}$$

► Now Try Exercise 39.

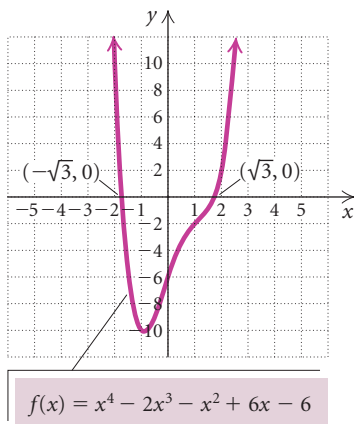

► Integer Coefficients and the Rational Zeros Theorem

It is not always easy to find the zeros of a polynomial function. However, if a polynomial function has integer coefficients, there is a procedure that will yield all the rational zeros.

The Rational Zeros Theorem

Let

$$P(x) = a_n x^n + a_{n-1} x^{n-1} + \cdots + a_1 x + a_0,$$

where all the coefficients are integers. Consider a rational number denoted by p/q , where p and q are relatively prime (having no common factor besides -1 and 1). If p/q is a zero of $P(x)$, then p is a factor of a_0 and q is a factor of a_n .

TECHNOLOGY CONNECTION

We can narrow the list of possibilities for the rational zeros of a function by examining its graph.

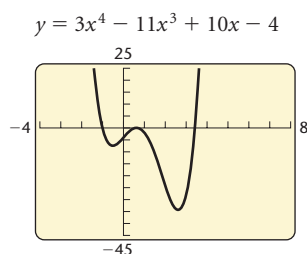

From the graph of the function in Example 5, we see that of the possibilities for rational zeros, only the numbers

$$-1, \frac{1}{3}, \frac{2}{3}$$

might actually be rational zeros.

We can check these with the TABLE feature. Note that the graphing calculator converts $\frac{1}{3}$ and $\frac{2}{3}$ to decimal notation.

X	Y1	
-1	0	
.33333	-1.037	
.66667	0	
X =		

Since $f(-1) = 0$ and $f(\frac{2}{3}) = 0$, -1 and $\frac{2}{3}$ are zeros. Since $f(\frac{1}{3}) \neq 0$, $\frac{1}{3}$ is not a zero.

EXAMPLE 5 Given $f(x) = 3x^4 - 11x^3 + 10x - 4$:

- Find the rational zeros and then the other zeros; that is, solve $f(x) = 0$.
- Factor $f(x)$ into linear factors.

Solution

- Because the degree of $f(x)$ is 4, there are at most 4 distinct zeros. The rational zeros theorem says that if a rational number p/q is a zero of $f(x)$, then p must be a factor of -4 and q must be a factor of 3. Thus the possibilities for p/q are

$$\frac{\text{Possibilities for } p}{\text{Possibilities for } q} = \frac{\pm 1, \pm 2, \pm 4}{\pm 1, \pm 3};$$

$$\text{Possibilities for } p/q: 1, -1, 2, -2, 4, -4, \frac{1}{3}, -\frac{1}{3}, \frac{2}{3}, -\frac{2}{3}, \frac{4}{3}, -\frac{4}{3}.$$

To find which are zeros, we could use substitution, but synthetic division is usually more efficient. It is easier to consider the integers first. Then we consider the fractions, if the integers do not produce all the zeros.

We try 1:

$$\begin{array}{r|rrrrrr} 1 & 3 & -11 & 0 & 10 & -4 \\ & & 3 & -8 & -8 & 2 \\ \hline & 3 & -8 & -8 & 2 & -2 \end{array}$$

Since $f(1) = -2$, 1 is not a zero.

We try -1 .

$$\begin{array}{r|rrrrrr} -1 & 3 & -11 & 0 & 10 & -4 \\ & & -3 & 14 & -14 & 4 \\ \hline & 3 & -14 & 14 & -4 & 0 \end{array}$$

We have $f(-1) = 0$, so -1 is a zero. Thus, $x + 1$ is a factor of $f(x)$. Using the results of the synthetic division, we can express $f(x)$ as

$$f(x) = (x + 1)(3x^3 - 14x^2 + 14x - 4).$$

We now consider the factor $3x^3 - 14x^2 + 14x - 4$ and check the other possible zeros. We use synthetic division again, to determine whether -1 is a zero of multiplicity 2 of $f(x)$:

$$\begin{array}{r|rrrr} -1 & 3 & -14 & 14 & -4 \\ & & -3 & 17 & -31 \\ \hline & 3 & -17 & 31 & -35 \end{array}$$

We see that -1 is not a double zero. We leave it to the student to verify that $2, -2, 4,$ and -4 are not zeros. There are no other possible zeros that are integers, so we start checking the fractions.

Let's try $\frac{2}{3}$.

$$\begin{array}{r|rrrr} 2/3 & 3 & -14 & 14 & -4 \\ & & 2 & -8 & 4 \\ \hline & 3 & -12 & 6 & 0 \end{array}$$

Since the remainder is 0, we know that $x - \frac{2}{3}$ is a factor of $3x^3 - 14x^2 + 14x - 4$ and is also a factor of $f(x)$. Thus, $\frac{2}{3}$ is a zero of $f(x)$.

Using the results of the synthetic division, we can factor further:

$$\begin{aligned} f(x) &= (x + 1)\left(x - \frac{2}{3}\right)(3x^2 - 12x + 6) && \text{Using the results of the} \\ & && \text{last synthetic division} \\ &= (x + 1)\left(x - \frac{2}{3}\right) \cdot 3 \cdot (x^2 - 4x + 2). && \text{Removing a factor of 3} \end{aligned}$$

The quadratic formula can be used to find the values of x for which $x^2 - 4x + 2 = 0$. Those values are also zeros of $f(x)$:

$$\begin{aligned} x &= \frac{-b \pm \sqrt{b^2 - 4ac}}{2a} \\ &= \frac{-(-4) \pm \sqrt{(-4)^2 - 4 \cdot 1 \cdot 2}}{2 \cdot 1} && a = 1, b = -4, \text{ and } c = 2 \\ &= \frac{4 \pm \sqrt{8}}{2} = \frac{4 \pm 2\sqrt{2}}{2} = \frac{2(2 \pm \sqrt{2})}{2} \\ &= 2 \pm \sqrt{2}. \end{aligned}$$

The rational zeros are -1 and $\frac{2}{3}$. The other zeros are $2 \pm \sqrt{2}$.

b) The complete factorization of $f(x)$ is

$$\begin{aligned} f(x) &= 3(x + 1)\left(x - \frac{2}{3}\right)\left[x - (2 - \sqrt{2})\right]\left[x - (2 + \sqrt{2})\right], \text{ or} \\ &= (x + 1)(3x - 2)\left[x - (2 - \sqrt{2})\right]\left[x - (2 + \sqrt{2})\right]. \end{aligned}$$

Replacing $3\left(x - \frac{2}{3}\right)$ with $(3x - 2)$

 Now Try Exercise 55.

EXAMPLE 6 Given $f(x) = 2x^5 - x^4 - 4x^3 + 2x^2 - 30x + 15$:

- Find the rational zeros and then the other zeros; that is, solve $f(x) = 0$.
- Factor $f(x)$ into linear factors.

Solution

- Because the degree of $f(x)$ is 5, there are at most 5 distinct zeros. According to the rational zeros theorem, any rational zero of f must be of the form p/q , where p is a factor of 15 and q is a factor of 2. The possibilities are

$$\begin{array}{l} \text{Possibilities for } p: \\ \text{Possibilities for } q: \end{array} \quad \begin{array}{l} \pm 1, \pm 3, \pm 5, \pm 15; \\ \pm 1, \pm 2 \end{array};$$

$$\text{Possibilities for } p/q: \quad 1, -1, 3, -3, 5, -5, 15, -15, \frac{1}{2}, -\frac{1}{2}, \frac{3}{2}, -\frac{3}{2}, \frac{5}{2}, -\frac{5}{2}, \frac{15}{2}, -\frac{15}{2}.$$

TECHNOLOGY CONNECTION

We can inspect the graph of the function in Example 6 for zeros that appear to be near any of the possible rational zeros.

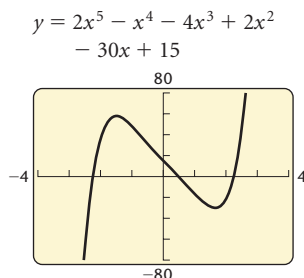

We see that, of the possibilities in the list, only the numbers

$$-\frac{5}{2}, \frac{1}{2}, \text{ and } \frac{5}{2}$$

might be rational zeros. With the TABLE feature, we can determine that only $\frac{1}{2}$ is actually a rational zero.

X	Y1
-2.5	-69.38
.5	0
2.5	46.25

We use synthetic division to check each of the possibilities. Let's try 1 and -1 .

$$\begin{array}{r|rrrrrr} 1 & 2 & -1 & -4 & 2 & -30 & 15 \\ & & 2 & 1 & -3 & -1 & -31 \\ \hline & 2 & 1 & -3 & -1 & -31 & -16 \end{array}$$

$$\begin{array}{r|rrrrrr} -1 & 2 & -1 & -4 & 2 & -30 & 15 \\ & & -2 & 3 & 1 & -3 & 33 \\ \hline & 2 & -3 & -1 & 3 & -33 & 48 \end{array}$$

Since $f(1) = -16$ and $f(-1) = 48$, neither 1 nor -1 is a zero of the function. We leave it to the student to verify that the other integer possibilities are not zeros. We now check $\frac{1}{2}$.

$$\begin{array}{r|rrrrrr} 1/2 & 2 & -1 & -4 & 2 & -30 & 15 \\ & & 1 & 0 & -2 & 0 & -15 \\ \hline & 2 & 0 & -4 & 0 & -30 & 0 \end{array}$$

This means that $x - \frac{1}{2}$ is a factor of $f(x)$. We write the factorization and try to factor further:

$$\begin{aligned} f(x) &= \left(x - \frac{1}{2}\right)(2x^4 - 4x^2 - 30) \\ &= \left(x - \frac{1}{2}\right) \cdot 2 \cdot (x^4 - 2x^2 - 15) && \text{Factoring out the 2} \\ &= \left(x - \frac{1}{2}\right) \cdot 2 \cdot (x^2 - 5)(x^2 + 3). && \text{Factoring the trinomial} \end{aligned}$$

We now solve the equation $f(x) = 0$ to determine the zeros. We use the principle of zero products:

$$\begin{aligned} \left(x - \frac{1}{2}\right) \cdot 2 \cdot (x^2 - 5)(x^2 + 3) &= 0 \\ x - \frac{1}{2} = 0 & \text{ or } x^2 - 5 = 0 & \text{ or } x^2 + 3 = 0 \\ x = \frac{1}{2} & \text{ or } x^2 = 5 & \text{ or } x^2 = -3 \\ x = \frac{1}{2} & \text{ or } x = \pm\sqrt{5} & \text{ or } x = \pm\sqrt{3}i. \end{aligned}$$

There is only one rational zero, $\frac{1}{2}$. The other zeros are $\pm\sqrt{5}$ and $\pm\sqrt{3}i$.

b) The factorization into linear factors is

$$\begin{aligned} f(x) &= 2\left(x - \frac{1}{2}\right)(x + \sqrt{5})(x - \sqrt{5})(x + \sqrt{3}i)(x - \sqrt{3}i), \text{ or} \\ &= (2x - 1)(x + \sqrt{5})(x - \sqrt{5})(x + \sqrt{3}i)(x - \sqrt{3}i). \end{aligned}$$

Replacing $2\left(x - \frac{1}{2}\right)$ with $(2x - 1)$

Now Try Exercise 61.

► Descartes' Rule of Signs

The development of a rule that helps determine the number of positive real zeros and the number of negative real zeros of a polynomial function is credited to the French mathematician René Descartes. To use the rule, we must have the polynomial arranged in descending or ascending order, with no zero terms written in and the constant term not 0. Then we determine the number of *variations of sign*, that is, the number of times, in reading through the polynomial, that successive coefficients are of different signs.

EXAMPLE 7 Determine the number of variations of sign in the polynomial function $P(x) = 2x^5 - 3x^2 + x + 4$.

Solution We have

$$P(x) = \underbrace{2x^5}_{\substack{\text{From positive to} \\ \text{negative; a variation}}} - \underbrace{3x^2}_{\substack{\text{From negative to positive;} \\ \text{a variation}}} + \underbrace{x + 4}_{\substack{\text{Both positive; no variation}}}$$

The number of variations of sign is 2. 

Note the following:

$$\begin{aligned} P(-x) &= 2(-x)^5 - 3(-x)^2 + (-x) + 4 \\ &= -2x^5 - 3x^2 - x + 4. \end{aligned}$$

We see that the number of variations of sign in $P(-x)$ is 1. It occurs as we go from $-x$ to 4.

We now state Descartes' rule, without proof.

Descartes' Rule of Signs

Let $P(x)$ written in descending or ascending order be a polynomial function with real coefficients and a nonzero constant term. The number of positive real zeros of $P(x)$ is either:

1. The same as the number of variations of sign in $P(x)$, or
2. Less than the number of variations of sign in $P(x)$ by a positive even integer.

The number of negative real zeros of $P(x)$ is either:

3. The same as the number of variations of sign in $P(-x)$, or
4. Less than the number of variations of sign in $P(-x)$ by a positive even integer.

A zero of multiplicity m must be counted m times.

In each of Examples 8–10, what does Descartes' rule of signs tell you about the number of positive real zeros and the number of negative real zeros?

EXAMPLE 8 $P(x) = 2x^5 - 5x^2 - 3x + 6$

Solution The number of variations of sign in $P(x)$ is 2. Therefore, the number of positive real zeros is either 2 or less than 2 by 2, 4, 6, and so on. Thus the number of positive real zeros is either 2 or 0, since a negative number of zeros has no meaning.

$$P(-x) = -2x^5 - 5x^2 + 3x + 6$$

Total Number of Zeros	5	
Positive Real	2	0
Negative Real	1	1
Nonreal	2	4

STUDY TIP

It is never too soon to begin reviewing for the final examination. The Skill Maintenance exercises found in each exercise set review and reinforce skills taught in earlier sections. Be sure to do these exercises as you do the homework assignment in each section. Answers to all of the skill maintenance exercises, along with section references, appear at the back of the book.

Total Number of Zeros	6	
0 as a Zero	1	1
Positive Real	1	1
Negative Real	2	0
Nonreal	2	4

The number of variations of sign in $P(-x)$ is 1. Thus there is exactly 1 negative real zero. Since nonreal, complex conjugates occur in pairs, we also know the possible ways in which nonreal zeros might occur. The table shown at left summarizes all the possibilities for real zeros and nonreal zeros of $P(x)$.

➔ Now Try Exercise 93.

EXAMPLE 9 $P(x) = 5x^4 - 3x^3 + 7x^2 - 12x + 4$

Solution There are 4 variations of sign. Thus the number of positive real zeros is either

$$4 \text{ or } 4 - 2 \text{ or } 4 - 4.$$

That is, the number of positive real zeros is 4, 2, or 0.

$$P(-x) = 5x^4 + 3x^3 + 7x^2 + 12x + 4$$

There are 0 changes in sign, so there are no negative real zeros.

➔ Now Try Exercise 81.

EXAMPLE 10 $P(x) = 6x^6 - 2x^2 - 5x$

Solution As written, the polynomial does not satisfy the conditions of Descartes' rule of signs because the constant term is 0. But because x is a factor of every term, we know that the polynomial has 0 as a zero. We can then factor as follows:

$$P(x) = x(6x^5 - 2x - 5).$$

Now we analyze $Q(x) = 6x^5 - 2x - 5$ and $Q(-x) = -6x^5 + 2x - 5$. The number of variations of sign in $Q(x)$ is 1. Therefore, there is exactly 1 positive real zero. The number of variations of sign in $Q(-x)$ is 2. Thus the number of negative real zeros is 2 or 0. The same results apply to $P(x)$. Since nonreal, complex conjugates occur in pairs, we know the possible ways in which nonreal zeros might occur. The table at left summarizes all the possibilities for real zeros and nonreal zeros of $P(x)$.

➔ Now Try Exercise 95.

4.4

Exercise Set

Find a polynomial function of degree 3 with the given numbers as zeros.

1. $-2, 3, 5$

2. $-1, 0, 4$

3. $-3, 2i, -2i$

4. $2, i, -i$

5. $\sqrt{2}, -\sqrt{2}, 3$

6. $-5, \sqrt{3}, -\sqrt{3}$

7. $1 - \sqrt{3}, 1 + \sqrt{3}, -2$

8. $-4, 1 - \sqrt{5}, 1 + \sqrt{5}$

9. $1 + 6i, 1 - 6i, -4$
 10. $1 + 4i, 1 - 4i, -1$
 11. $-\frac{1}{3}, 0, 2$
 12. $-3, 0, \frac{1}{2}$
 13. Find a polynomial function of degree 5 with -1 as a zero of multiplicity 3, 0 as a zero of multiplicity 1, and 1 as a zero of multiplicity 1.
 14. Find a polynomial function of degree 4 with -2 as a zero of multiplicity 1, 3 as a zero of multiplicity 2, and -1 as a zero of multiplicity 1.
 15. Find a polynomial function of degree 4 with $a_4 = 1$ and with -1 as a zero of multiplicity 3 and 0 as a zero of multiplicity 1.
 16. Find a polynomial function of degree 5 with $a_5 = 1$ and with $-\frac{1}{2}$ as a zero of multiplicity 2, 0 as a zero of multiplicity 1, and 1 as a zero of multiplicity 2.

Suppose that a polynomial function of degree 4 with rational coefficients has the given numbers as zeros. Find the other zero(s).

17. $-1, \sqrt{3}, \frac{11}{3}$ 18. $-\sqrt{2}, -1, \frac{4}{5}$
 19. $-i, 2 - \sqrt{5}$ 20. $i, -3 + \sqrt{3}$
 21. $3i, 0, -5$ 22. $3, 0, -2i$
 23. $-4 - 3i, 2 - \sqrt{3}$ 24. $6 - 5i, -1 + \sqrt{7}$

Suppose that a polynomial function of degree 5 with rational coefficients has the given numbers as zeros. Find the other zero(s).

25. $-\frac{1}{2}, \sqrt{5}, -4i$ 26. $\frac{3}{4}, -\sqrt{3}, 2i$
 27. $-5, 0, 2 - i, 4$ 28. $-2, 3, 4, 1 - i$
 29. $6, -3 + 4i, 4 - \sqrt{5}$
 30. $-3 - 3i, 2 + \sqrt{13}, 6$
 31. $-\frac{3}{4}, \frac{3}{4}, 0, 4 - i$
 32. $-0.6, 0, 0.6, -3 + \sqrt{2}$

Find a polynomial function of lowest degree with rational coefficients that has the given numbers as some of its zeros.

33. $1 + i, 2$ 34. $2 - i, -1$
 35. $4i$ 36. $-5i$
 37. $-4i, 5$ 38. $3, -i$
 39. $1 - i, -\sqrt{5}$ 40. $2 - \sqrt{3}, 1 + i$
 41. $\sqrt{5}, -3i$ 42. $-\sqrt{2}, 4i$

Given that the polynomial function has the given zero, find the other zeros.

43. $f(x) = x^3 + 5x^2 - 2x - 10; -5$
 44. $f(x) = x^3 - x^2 + x - 1; 1$
 45. $f(x) = x^4 - 5x^3 + 7x^2 - 5x + 6; -i$
 46. $f(x) = x^4 - 16; 2i$
 47. $f(x) = x^3 - 6x^2 + 13x - 20; 4$
 48. $f(x) = x^3 - 8; 2$

List all possible rational zeros of the function.

49. $f(x) = x^5 - 3x^2 + 1$
 50. $f(x) = x^7 + 37x^5 - 6x^2 + 12$
 51. $f(x) = 2x^4 - 3x^3 - x + 8$
 52. $f(x) = 3x^3 - x^2 + 6x - 9$
 53. $f(x) = 15x^6 + 47x^2 + 2$
 54. $f(x) = 10x^{25} + 3x^{17} - 35x + 6$

For each polynomial function:

- a) Find the rational zeros and then the other zeros; that is, solve $f(x) = 0$.
 b) Factor $f(x)$ into linear factors.
55. $f(x) = x^3 + 3x^2 - 2x - 6$
 56. $f(x) = x^3 - x^2 - 3x + 3$
 57. $f(x) = 3x^3 - x^2 - 15x + 5$
 58. $f(x) = 4x^3 - 4x^2 - 3x + 3$
 59. $f(x) = x^3 - 3x + 2$
 60. $f(x) = x^3 - 2x + 4$
 61. $f(x) = 2x^3 + 3x^2 + 18x + 27$
 62. $f(x) = 2x^3 + 7x^2 + 2x - 8$
 63. $f(x) = 5x^4 - 4x^3 + 19x^2 - 16x - 4$
 64. $f(x) = 3x^4 - 4x^3 + x^2 + 6x - 2$
 65. $f(x) = x^4 - 3x^3 - 20x^2 - 24x - 8$
 66. $f(x) = x^4 + 5x^3 - 27x^2 + 31x - 10$
 67. $f(x) = x^3 - 4x^2 + 2x + 4$
 68. $f(x) = x^3 - 8x^2 + 17x - 4$
 69. $f(x) = x^3 + 8$
 70. $f(x) = x^3 - 8$
 71. $f(x) = \frac{1}{3}x^3 - \frac{1}{2}x^2 - \frac{1}{6}x + \frac{1}{6}$
 72. $f(x) = \frac{2}{3}x^3 - \frac{1}{2}x^2 + \frac{2}{3}x - \frac{1}{2}$

Find only the rational zeros of the function.

73. $f(x) = x^4 + 2x^3 - 5x^2 - 4x + 6$

74. $f(x) = x^4 - 3x^3 - 9x^2 - 3x - 10$

75. $f(x) = x^3 - x^2 - 4x + 3$

76. $f(x) = 2x^3 + 3x^2 + 2x + 3$

77. $f(x) = x^4 + 2x^3 + 2x^2 - 4x - 8$

78. $f(x) = x^4 + 6x^3 + 17x^2 + 36x + 66$

79. $f(x) = x^5 - 5x^4 + 5x^3 + 15x^2 - 36x + 20$

80. $f(x) = x^5 - 3x^4 - 3x^3 + 9x^2 - 4x + 12$

What does Descartes' rule of signs tell you about the number of positive real zeros and the number of negative real zeros of the function?

81. $f(x) = 3x^5 - 2x^2 + x - 1$

82. $g(x) = 5x^6 - 3x^3 + x^2 - x$

83. $h(x) = 6x^7 + 2x^2 + 5x + 4$

84. $P(x) = -3x^5 - 7x^3 - 4x - 5$

85. $F(p) = 3p^{18} + 2p^4 - 5p^2 + p + 3$

86. $H(t) = 5t^{12} - 7t^4 + 3t^2 + t + 1$

87. $C(x) = 7x^6 + 3x^4 - x - 10$

88. $g(z) = -z^{10} + 8z^7 + z^3 + 6z - 1$

89. $h(t) = -4t^5 - t^3 + 2t^2 + 1$

90. $P(x) = x^6 + 2x^4 - 9x^3 - 4$

91. $f(y) = y^4 + 13y^3 - y + 5$

92. $Q(x) = x^4 - 2x^2 + 12x - 8$

93. $r(x) = x^4 - 6x^2 + 20x - 24$

94. $f(x) = x^5 - 2x^3 - 8x$

95. $R(x) = 3x^5 - 5x^3 - 4x$

96. $f(x) = x^4 - 9x^2 - 6x + 4$

Sketch the graph of the polynomial function. Follow the procedure outlined on p. 311. Use the rational zeros theorem when finding the zeros.

97. $f(x) = 4x^3 + x^2 - 8x - 2$

98. $f(x) = 3x^3 - 4x^2 - 5x + 2$

99. $f(x) = 2x^4 - 3x^3 - 2x^2 + 3x$

100. $f(x) = 4x^4 - 37x^2 + 9$

Skill Maintenance

For Exercises 101 and 102, complete the square to:

- find the vertex;
- find the axis of symmetry; and
- determine whether there is a maximum or minimum function value and find that value.

101. $f(x) = x^2 - 8x + 10$

102. $f(x) = 3x^2 - 6x - 1$

Find the zeros of the function.

103. $f(x) = -\frac{4}{5}x + 8$

104. $g(x) = x^2 - 8x - 33$

Determine the leading term, the leading coefficient, and the degree of the polynomial. Then describe the end behavior of the function's graph and classify the polynomial function as constant, linear, quadratic, cubic, or quartic.

105. $g(x) = -x^3 - 2x^2$

106. $f(x) = -x^2 - 3x + 6$

107. $f(x) = -\frac{4}{9}$

108. $h(x) = x - 2$

109. $g(x) = x^4 - 2x^3 + x^2 - x + 2$

110. $h(x) = x^3 + \frac{1}{2}x^2 - 4x - 3$

Synthesis

111. Consider $f(x) = 2x^3 - 5x^2 - 4x + 3$. Find the solutions of each equation.

- | | |
|-------------------|-------------------|
| a) $f(x) = 0$ | b) $f(x - 1) = 0$ |
| c) $f(x + 2) = 0$ | d) $f(2x) = 0$ |

112. Use the rational zeros theorem and the equation $x^4 - 12 = 0$ to show that $\sqrt[4]{12}$ is irrational.

Find the rational zeros of the function.

113. $P(x) = 2x^5 - 33x^4 - 84x^3 + 2203x^2 - 3348x - 10,080$

114. $P(x) = x^6 - 6x^5 - 72x^4 - 81x^2 + 486x + 5832$

Rational Functions

4.5

- ▶ For a rational function, find the domain and graph the function, identifying all of the asymptotes.
- ▶ Solve applied problems involving rational functions.

Now we turn our attention to functions that represent the quotient of two polynomials. Whereas the sum, difference, or product of two polynomials is a polynomial, in general the quotient of two polynomials is *not* itself a polynomial.

A *rational number* can be expressed as the quotient of two integers, p/q , where $q \neq 0$. A *rational function* is formed by the quotient of two polynomials, $p(x)/q(x)$, where $q(x) \neq 0$. Here are some examples of rational functions and their graphs.

$$f(x) = \frac{1}{x}$$

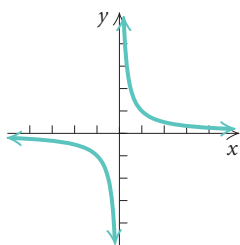

$$f(x) = \frac{1}{x^2}$$

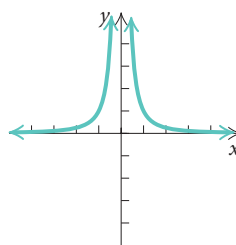

$$f(x) = \frac{x-3}{x^2+x-2}$$

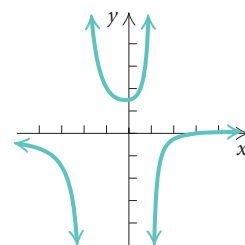

$$f(x) = \frac{2x+5}{2x-6}$$

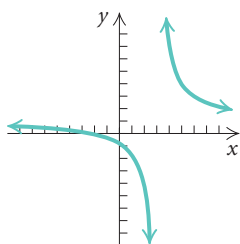

$$f(x) = \frac{x^2+2x-3}{x^2-x-2}$$

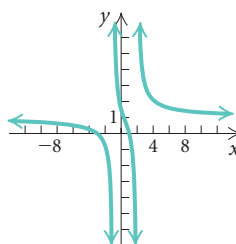

$$f(x) = \frac{-x^2}{x+1}$$

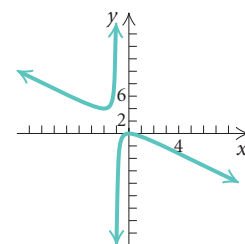
**Rational Function**

A **rational function** is a function f that is a quotient of two polynomials. That is,

$$f(x) = \frac{p(x)}{q(x)},$$

where $p(x)$ and $q(x)$ are polynomials and where $q(x)$ is not the zero polynomial. The domain of f consists of all inputs x for which $q(x) \neq 0$.

► The Domain of a Rational Function

EXAMPLE 1 Consider

$$f(x) = \frac{1}{x - 3}.$$

Find the domain and graph f .

Solution When the denominator $x - 3$ is 0, we have $x = 3$, so the only input that results in a denominator of 0 is 3. Thus the domain is

$$\{x \mid x \neq 3\}, \text{ or } (-\infty, 3) \cup (3, \infty).$$

The graph of this function is the graph of $y = 1/x$ translated right 3 units.

DOMAINS OF FUNCTIONS

REVIEW SECTION 1.2

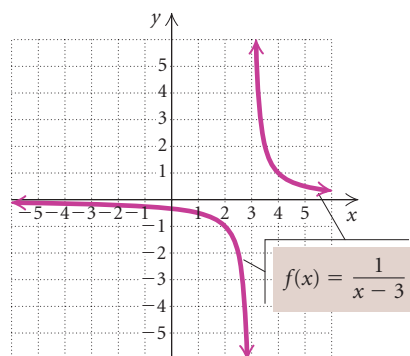

TECHNOLOGY CONNECTION

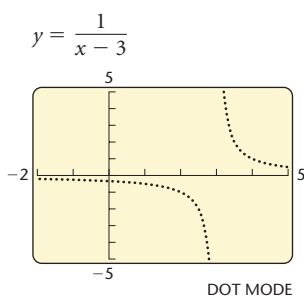
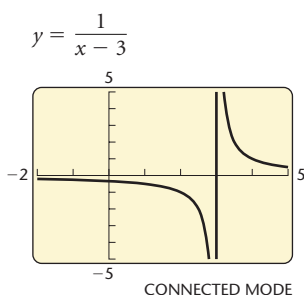

The graphs at left show the function $f(x) = 1/(x - 3)$ graphed in CONNECTED mode and in DOT mode. Using CONNECTED mode can lead to an incorrect graph. In CONNECTED mode, a graphing calculator connects plotted points with line segments. In DOT mode, it simply plots unconnected points. In the first graph, the graphing calculator has connected the points plotted on either side of the x -value 3 with a line that appears to be the vertical line $x = 3$. (It is not actually vertical since it connects the last point to the left of $x = 3$ with the first point to the right of $x = 3$.) Since 3 is not in the domain of the function, the vertical line $x = 3$ cannot be part of the graph. We will see later in this section that vertical lines like $x = 3$, although not part of the graph, are important in the construction of graphs. If you have a choice when graphing rational functions, use DOT mode.

EXAMPLE 2 Determine the domain of each of the functions illustrated at the beginning of this section.

Solution The domain of each rational function will be the set of all real numbers except those values that make the denominator 0. To determine those exceptions, we set the denominator equal to 0 and solve for x .

FUNCTION	DOMAIN
$f(x) = \frac{1}{x}$	$\{x \mid x \neq 0\}$, or $(-\infty, 0) \cup (0, \infty)$
$f(x) = \frac{1}{x^2}$	$\{x \mid x \neq 0\}$, or $(-\infty, 0) \cup (0, \infty)$
$f(x) = \frac{x-3}{x^2+x-2} = \frac{x-3}{(x+2)(x-1)}$	$\{x \mid x \neq -2 \text{ and } x \neq 1\}$, or $(-\infty, -2) \cup (-2, 1) \cup (1, \infty)$
$f(x) = \frac{2x+5}{2x-6} = \frac{2x+5}{2(x-3)}$	$\{x \mid x \neq 3\}$, or $(-\infty, 3) \cup (3, \infty)$
$f(x) = \frac{x^2+2x-3}{x^2-x-2} = \frac{x^2+2x-3}{(x+1)(x-2)}$	$\{x \mid x \neq -1 \text{ and } x \neq 2\}$, or $(-\infty, -1) \cup (-1, 2) \cup (2, \infty)$
$f(x) = \frac{-x^2}{x+1}$	$\{x \mid x \neq -1\}$, or $(-\infty, -1) \cup (-1, \infty)$

As a partial check of the domains, we can observe the discontinuities (breaks) in the graphs of these functions. (See p. 340.)



► Asymptotes

Vertical Asymptotes

Look at the graph of $f(x) = 1/(x-3)$, shown at left. (Also see Example 1.) Let's explore what happens as x -values get closer and closer to 3 from the left. We then explore what happens as x -values get closer and closer to 3 from the right.

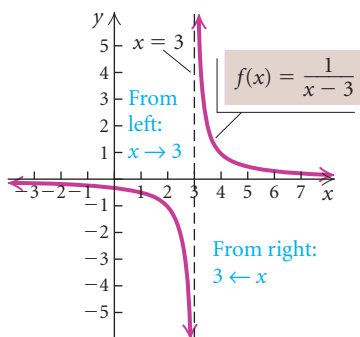

Vertical asymptote: $x = 3$

From the left:

x	2	$2\frac{1}{2}$	$2\frac{99}{100}$	$2\frac{9999}{10,000}$	$2\frac{999,999}{1,000,000}$	$\rightarrow 3$
$f(x)$	-1	-2	-100	-10,000	-1,000,000	$\rightarrow -\infty$

From the right:

x	4	$3\frac{1}{2}$	$3\frac{1}{100}$	$3\frac{1}{10,000}$	$3\frac{1}{1,000,000}$	$\rightarrow 3$
$f(x)$	1	2	100	10,000	1,000,000	$\rightarrow \infty$

We see that as x -values get closer and closer to 3 from the left, the function values (y -values) decrease without bound (that is, they approach negative infinity, $-\infty$). Similarly, as the x -values approach 3 from the right, the function values increase without bound (that is, they approach positive infinity, ∞). We write this as

$$f(x) \rightarrow -\infty \text{ as } x \rightarrow 3^- \quad \text{and} \quad f(x) \rightarrow \infty \text{ as } x \rightarrow 3^+.$$

We read “ $f(x) \rightarrow -\infty$ as $x \rightarrow 3^-$ ” as “ $f(x)$ decreases without bound as x approaches 3 from the left.” We read “ $f(x) \rightarrow \infty$ as $x \rightarrow 3^+$ ” as “ $f(x)$ increases without bound as x approaches 3 from the right.” The notation $x \rightarrow 3$ means that x gets as close to 3 as possible without being equal to 3. The vertical line $x = 3$ is said to be a *vertical asymptote* for this curve.

In general, the line $x = a$ is a **vertical asymptote** for the graph of f if any of the following is true:

$$\begin{aligned} f(x) \rightarrow \infty \text{ as } x \rightarrow a^-, \quad \text{or} \quad f(x) \rightarrow -\infty \text{ as } x \rightarrow a^-, \quad \text{or} \\ f(x) \rightarrow \infty \text{ as } x \rightarrow a^+, \quad \text{or} \quad f(x) \rightarrow -\infty \text{ as } x \rightarrow a^+. \end{aligned}$$

The following figures show the four ways in which a vertical asymptote can occur.

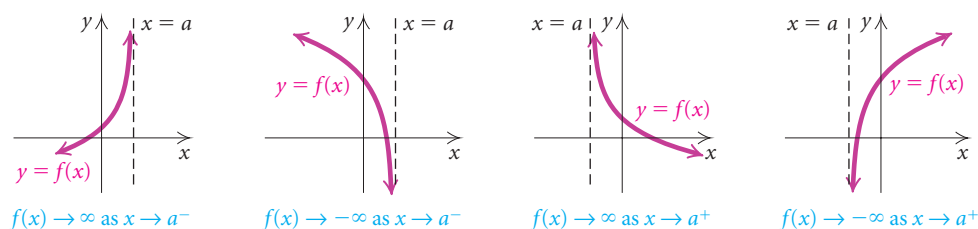

The vertical asymptotes of a rational function $f(x) = p(x)/q(x)$ are found by determining the zeros of $q(x)$ that are not also zeros of $p(x)$. If $p(x)$ and $q(x)$ are polynomials with no common factors other than constants, we need determine only the zeros of the denominator $q(x)$.

Determining Vertical Asymptotes

For a rational function $f(x) = p(x)/q(x)$, where $p(x)$ and $q(x)$ are polynomials with *no common factors* other than constants, if a is a zero of the denominator, then the line $x = a$ is a vertical asymptote for the graph of the function.

EXAMPLE 3 Determine the vertical asymptotes for the graph of each of the following functions.

a) $f(x) = \frac{2x - 11}{x^2 + 2x - 8}$

b) $h(x) = \frac{x^2 - 4x}{x^3 - x}$

c) $g(x) = \frac{x - 2}{x^3 - 5x}$

Solution

a) First, we factor the denominator:

$$f(x) = \frac{2x - 11}{x^2 + 2x - 8} = \frac{2x - 11}{(x + 4)(x - 2)}.$$

The numerator and the denominator have no common factors. The zeros of the denominator are -4 and 2 . Thus the vertical asymptotes for the graph of $f(x)$ are the lines $x = -4$ and $x = 2$. (See Fig. 1.)

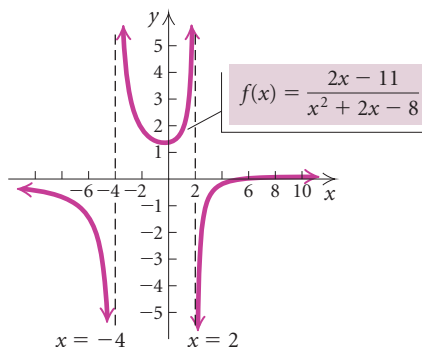

Figure 1

b) We factor the numerator and the denominator:

$$h(x) = \frac{x^2 - 4x}{x^3 - x} = \frac{x(x - 4)}{x(x^2 - 1)} = \frac{x(x - 4)}{x(x + 1)(x - 1)}.$$

The domain of the function is $\{x \mid x \neq -1 \text{ and } x \neq 0 \text{ and } x \neq 1\}$, or $(-\infty, -1) \cup (-1, 0) \cup (0, 1) \cup (1, \infty)$. Note that the numerator and the denominator share a common factor, x . The vertical asymptotes of $h(x)$ are found by determining the zeros of the denominator, $x(x + 1)(x - 1)$, that are *not* also zeros of the numerator, $x(x - 4)$. The zeros of $x(x + 1)(x - 1)$ are 0 , -1 , and 1 . The zeros of $x(x - 4)$ are 0 and 4 . Thus, although the denominator has three zeros, the graph of $h(x)$ has only two vertical asymptotes, $x = -1$ and $x = 1$. (See Fig. 2.)

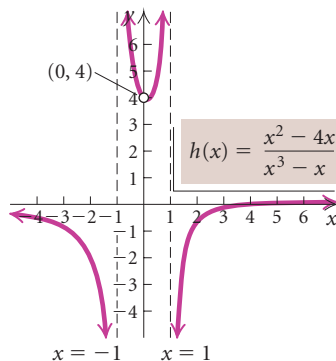

Figure 2

The rational expression $[x(x - 4)]/[x(x + 1)(x - 1)]$ can be simplified. Thus,

$$h(x) = \frac{x(x - 4)}{x(x + 1)(x - 1)} = \frac{x - 4}{(x + 1)(x - 1)},$$

where $x \neq 0$, $x \neq -1$, and $x \neq 1$. The graph of $h(x)$ is the graph of

$$h(x) = \frac{x - 4}{(x + 1)(x - 1)}$$

with the point where $x = 0$ missing. To determine the y -coordinate of the “hole,” we substitute 0 for x :

$$h(0) = \frac{0 - 4}{(0 + 1)(0 - 1)} = \frac{-4}{1 \cdot (-1)} = 4.$$

Thus the “hole” is located at $(0, 4)$.

c) We factor the denominator:

$$g(x) = \frac{x - 2}{x^3 - 5x} = \frac{x - 2}{x(x^2 - 5)}.$$

The numerator and the denominator have no common factors. We find the zeros of the denominator, $x(x^2 - 5)$. Solving $x(x^2 - 5) = 0$, we get

$$\begin{aligned} x = 0 \quad \text{or} \quad x^2 - 5 &= 0 \\ x = 0 \quad \text{or} \quad x^2 &= 5 \\ x = 0 \quad \text{or} \quad x &= \pm\sqrt{5}. \end{aligned}$$

The zeros of the denominator are 0, $\sqrt{5}$, and $-\sqrt{5}$. Thus the vertical asymptotes are the lines $x = 0$, $x = \sqrt{5}$, and $x = -\sqrt{5}$. (See Fig. 3.)

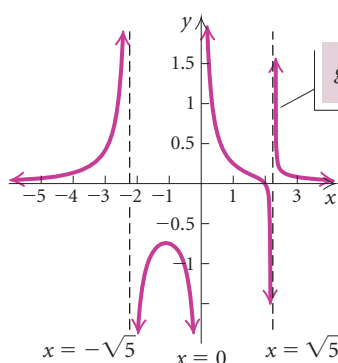
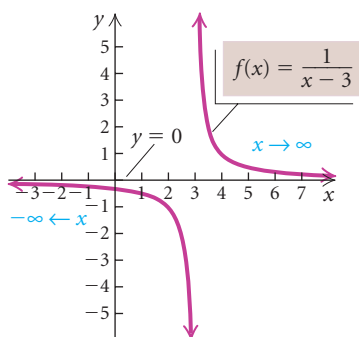

Figure 3

➔ Now Try Exercises 15 and 19.

Horizontal Asymptotes

Looking again at the graph of $f(x) = 1/(x - 3)$, shown at left (also see Example 1), let's explore what happens to $f(x) = 1/(x - 3)$ as x increases without bound (approaches positive infinity, ∞) and as x decreases without bound (approaches negative infinity, $-\infty$).



Horizontal asymptote: $y = 0$

x increases without bound:

x	100	5000	1,000,000	$\rightarrow \infty$
$f(x)$	≈ 0.0103	≈ 0.0002	≈ 0.000001	$\rightarrow 0$

x decreases without bound:

x	-300	-8000	-1,000,000	$\rightarrow -\infty$
$f(x)$	≈ -0.0033	≈ -0.0001	≈ -0.000001	$\rightarrow 0$

We see that

$$\frac{1}{x-3} \rightarrow 0 \text{ as } x \rightarrow \infty \quad \text{and} \quad \frac{1}{x-3} \rightarrow 0 \text{ as } x \rightarrow -\infty.$$

Since $y = 0$ is the equation of the x -axis, we say that the curve approaches the x -axis asymptotically and that the x -axis is a *horizontal asymptote* for the curve.

In general, the line $y = b$ is a **horizontal asymptote** for the graph of f if either or both of the following are true:

$$f(x) \rightarrow b \text{ as } x \rightarrow \infty \quad \text{or} \quad f(x) \rightarrow b \text{ as } x \rightarrow -\infty.$$

The following figures illustrate four ways in which horizontal asymptotes can occur. In each case, the curve gets close to the line $y = b$ either as $x \rightarrow \infty$ or as $x \rightarrow -\infty$. Keep in mind that the symbols ∞ and $-\infty$ convey the idea of increasing without bound and decreasing without bound, respectively.

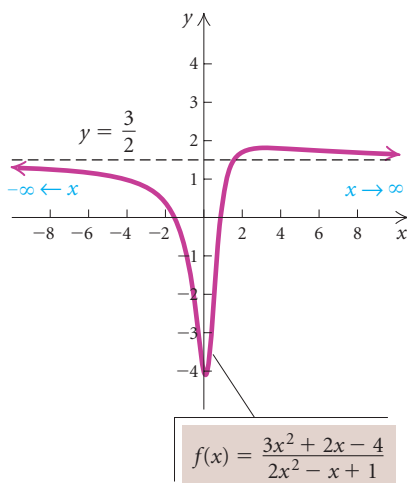
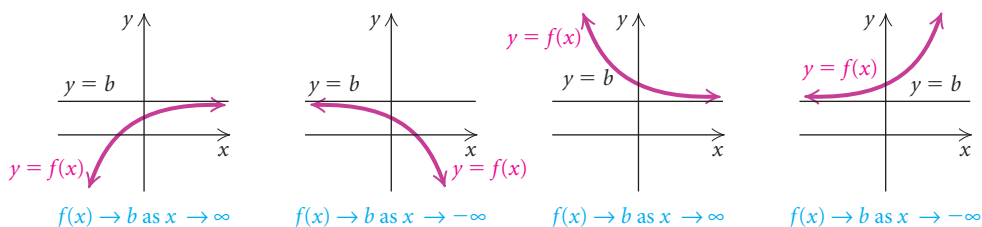

How can we determine a horizontal asymptote? As x gets very large or very small, the value of a polynomial function $p(x)$ is dominated by the function's leading term. Because of this, if $p(x)$ and $q(x)$ have the *same* degree, the value of $p(x)/q(x)$ as $x \rightarrow \infty$ or as $x \rightarrow -\infty$ is dominated by the ratio of the numerator's leading coefficient to the denominator's leading coefficient.

For $f(x) = (3x^2 + 2x - 4)/(2x^2 - x + 1)$, we see that the numerator, $3x^2 + 2x - 4$, is dominated by $3x^2$ and the denominator, $2x^2 - x + 1$, is dominated by $2x^2$, so $f(x)$ approaches $3x^2/2x^2$, or $3/2$ as x gets very large or very small:

$$\frac{3x^2 + 2x - 4}{2x^2 - x + 1} \rightarrow \frac{3}{2}, \text{ or } 1.5, \text{ as } x \rightarrow \infty, \quad \text{and}$$

$$\frac{3x^2 + 2x - 4}{2x^2 - x + 1} \rightarrow \frac{3}{2}, \text{ or } 1.5, \text{ as } x \rightarrow -\infty.$$

We say that the curve approaches the horizontal line $y = \frac{3}{2}$ asymptotically and that $y = \frac{3}{2}$ is a *horizontal asymptote* for the curve.

It follows that when the numerator and the denominator of a rational function have the same degree, the line $y = a/b$ is the horizontal asymptote, where a and b are the leading coefficients of the numerator and the denominator, respectively.

EXAMPLE 4 Find the horizontal asymptote: $f(x) = \frac{-7x^4 - 10x^2 + 1}{11x^4 + x - 2}$.

Solution The numerator and the denominator have the same degree. The ratio of the leading coefficients is $-\frac{7}{11}$, so the line $y = -\frac{7}{11}$, or $-0.\overline{63}$, is the horizontal asymptote.

Now Try Exercise 21.

TECHNOLOGY CONNECTION

We can check Example 4 by using a graphing calculator to evaluate the function for a very large and a very small value of x .

X	Y1	
100000	-.6364	
-80000	-.6364	
X =		

For each number, the function value is close to $-0.\overline{63}$, or $-\frac{7}{11}$.

To check Example 4, we could evaluate the function for a very large and a very small value of x . Another check, one that is useful in calculus, is to multiply by 1, using $(1/x^4)/(1/x^4)$:

$$\begin{aligned} f(x) &= \frac{-7x^4 - 10x^2 + 1}{11x^4 + x - 2} \cdot \frac{1/x^4}{1/x^4} = \frac{-7x^4}{x^4} - \frac{10x^2}{x^4} + \frac{1}{x^4} \\ &= \frac{-7 - \frac{10}{x^2} + \frac{1}{x^4}}{11 + \frac{1}{x^3} - \frac{2}{x^4}}. \end{aligned}$$

As $|x|$ becomes very large, each expression whose denominator is a power of x tends toward 0. Specifically, as $x \rightarrow \infty$ or as $x \rightarrow -\infty$, we have

$$f(x) \rightarrow \frac{-7 - 0 + 0}{11 + 0 - 0}, \quad \text{or} \quad f(x) \rightarrow -\frac{7}{11}.$$

The horizontal asymptote is $y = -\frac{7}{11}$, or $-0.\overline{63}$.

We now investigate the occurrence of a horizontal asymptote when the degree of the numerator is less than the degree of the denominator.

EXAMPLE 5 Find the horizontal asymptote: $f(x) = \frac{2x + 3}{x^3 - 2x^2 + 4}$.

Solution We let $p(x) = 2x + 3$, $q(x) = x^3 - 2x^2 + 4$, and $f(x) = p(x)/q(x)$. Note that as $x \rightarrow \infty$, the value of $q(x)$ grows much faster than the value of $p(x)$. Because of this, the ratio $p(x)/q(x)$ shrinks toward 0. As $x \rightarrow -\infty$, the ratio $p(x)/q(x)$ behaves in a similar manner. The horizontal asymptote is $y = 0$, the x -axis. This is the case for all rational functions for which the degree of the numerator is less than the degree of the denominator. Note in Example 1 that $y = 0$, the x -axis, is the horizontal asymptote of $f(x) = 1/(x - 3)$.

 **Now Try Exercise 23.**

The following statements describe the two ways in which a horizontal asymptote occurs.

Determining a Horizontal Asymptote

- When the numerator and the denominator of a rational function have the same degree, the line $y = a/b$ is the horizontal asymptote, where a and b are the leading coefficients of the numerator and the denominator, respectively.
- When the degree of the numerator of a rational function is less than the degree of the denominator, the x -axis, or $y = 0$, is the horizontal asymptote.
- When the degree of the numerator of a rational function is greater than the degree of the denominator, there is no horizontal asymptote.

EXAMPLE 6 Graph

$$g(x) = \frac{2x^2 + 1}{x^2}.$$

Include and label all asymptotes.

Solution Since 0 is the zero of the denominator and not of the numerator, the y -axis, $x = 0$, is the vertical asymptote. Note also that the degree of the numerator is the same as the degree of the denominator. Thus, $y = 2/1$, or 2, is the horizontal asymptote.

To draw the graph, we first draw the asymptotes with dashed lines. Then we compute and plot some ordered pairs and draw the two branches of the curve.

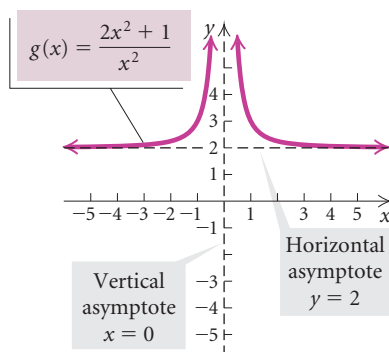

x	$g(x)$
-2	2.25
-1.5	2.4
-1	3
-0.5	6
0.5	6
1	3
1.5	2.4
2	2.25

Now Try Exercise 41.

Oblique Asymptotes

Sometimes a line that is neither horizontal nor vertical is an asymptote. Such a line is called an **oblique asymptote**, or a **slant asymptote**.

EXAMPLE 7 Find all the asymptotes of

$$f(x) = \frac{2x^2 - 3x - 1}{x - 2}.$$

Solution The line $x = 2$ is the vertical asymptote because 2 is the zero of the denominator and is not a zero of the numerator. There is no horizontal asymptote because the degree of the numerator is greater than the degree of the denominator. When the degree of the numerator is 1 greater than the degree of the denominator, we divide to find an equivalent expression:

$$\frac{2x^2 - 3x - 1}{x - 2} = (2x + 1) + \frac{1}{x - 2}.$$

$$\begin{array}{r} 2x + 1 \\ x - 2 \overline{) 2x^2 - 3x - 1} \\ \underline{2x^2 - 4x} \\ x - 1 \\ \underline{x - 2} \\ 1 \end{array}$$

Now we see that when $x \rightarrow \infty$ or $x \rightarrow -\infty$, $1/(x - 2) \rightarrow 0$ and the value of $f(x) \rightarrow 2x + 1$. This means that as $|x|$ becomes very large, the graph of $f(x)$ gets very close to the graph of $y = 2x + 1$. Thus the line $y = 2x + 1$ is the oblique asymptote.

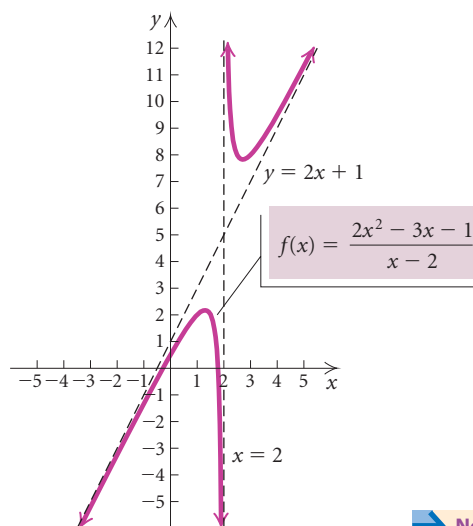

➔ Now Try Exercise 59.

Occurrence of Lines as Asymptotes of Rational Functions

For a rational function $f(x) = p(x)/q(x)$, where $p(x)$ and $q(x)$ have no common factors other than constants:

Vertical asymptotes occur at any x -values that make the denominator 0.

The x -axis is the horizontal asymptote when the degree of the numerator is less than the degree of the denominator.

A horizontal asymptote other than the x -axis occurs when the numerator and the denominator have the same degree.

An oblique asymptote occurs when the degree of the numerator is 1 greater than the degree of the denominator.

There can be only one horizontal asymptote or one oblique asymptote and never both.

An asymptote is *not* part of the graph of the function.

The following statements are also true.

Crossing an Asymptote

- The graph of a rational function *never* crosses a vertical asymptote.
- The graph of a rational function *might* cross a horizontal asymptote but does not necessarily do so.

The following is an outline of a procedure that we can follow to create accurate graphs of rational functions.

To graph a rational function $f(x) = p(x)/q(x)$, where $p(x)$ and $q(x)$ have no common factor other than constants:

1. Find any real zeros of the denominator. Determine the domain of the function and sketch any vertical asymptotes.
2. Find the horizontal asymptote or the oblique asymptote, if there is one, and sketch it.
3. Find any zeros of the function. The zeros are found by determining the zeros of the numerator. These are the first coordinates of the x -intercepts of the graph.
4. Find $f(0)$. This gives the y -intercept $(0, f(0))$, of the function.
5. Find other function values to determine the general shape. Then draw the graph.

EXAMPLE 8 Graph: $f(x) = \frac{2x + 3}{3x^2 + 7x - 6}$.

Solution

1. We find the zeros of the denominator by solving $3x^2 + 7x - 6 = 0$. Since

$$3x^2 + 7x - 6 = (3x - 2)(x + 3),$$

the zeros are $\frac{2}{3}$ and -3 . Thus the domain excludes $\frac{2}{3}$ and -3 and is

$$(-\infty, -3) \cup (-3, \frac{2}{3}) \cup (\frac{2}{3}, \infty).$$

Since neither zero of the denominator is a zero of the numerator, the graph has vertical asymptotes $x = -3$ and $x = \frac{2}{3}$. We sketch these as dashed lines.

2. Because the degree of the numerator is less than the degree of the denominator, the x -axis, $y = 0$, is the horizontal asymptote.
3. To find the zeros of the numerator, we solve $2x + 3 = 0$ and get $x = -\frac{3}{2}$. Thus, $-\frac{3}{2}$ is the zero of the function, and the pair $(-\frac{3}{2}, 0)$ is the x -intercept.
4. We find $f(0)$:

$$\begin{aligned} f(0) &= \frac{2 \cdot 0 + 3}{3 \cdot 0^2 + 7 \cdot 0 - 6} \\ &= \frac{3}{-6} = -\frac{1}{2}. \end{aligned}$$

The point $(0, -\frac{1}{2})$ is the y -intercept.

5. We find other function values to determine the general shape. We choose values in each interval of the domain as shown in the table at left and then draw the graph. Note that the graph of this function crosses its horizontal asymptote at $x = -\frac{3}{2}$.

x	y
-4.5	-0.26
-3.25	-1.19
-2.5	0.42
-0.5	-0.23
0.5	-2.29
0.75	4.8
1.5	0.53
3.5	0.18

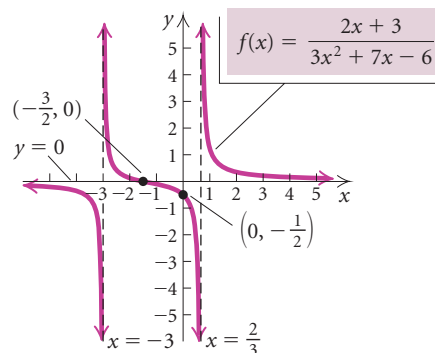

➔ Now Try Exercise 65.

EXAMPLE 9 Graph: $g(x) = \frac{x^2 - 1}{x^2 + x - 6}$.

Solution

1. We find the zeros of the denominator by solving $x^2 + x - 6 = 0$. Since

$$x^2 + x - 6 = (x + 3)(x - 2),$$

the zeros are -3 and 2 . Thus the domain excludes the x -values -3 and 2 and is

$$(-\infty, -3) \cup (-3, 2) \cup (2, \infty).$$

Since neither zero of the denominator is a zero of the numerator, the graph has vertical asymptotes $x = -3$ and $x = 2$. We sketch these as dashed lines.

2. The numerator and the denominator have the same degree, so the horizontal asymptote is determined by the ratio of the leading coefficients: $1/1$, or 1 . Thus, $y = 1$ is the horizontal asymptote. We sketch it with a dashed line.
3. To find the zeros of the numerator, we solve $x^2 - 1 = 0$. The solutions are -1 and 1 . Thus, -1 and 1 are the zeros of the function and the pairs $(-1, 0)$ and $(1, 0)$ are the x -intercepts.
4. We find $g(0)$:

$$g(0) = \frac{0^2 - 1}{0^2 + 0 - 6} = \frac{-1}{-6} = \frac{1}{6}.$$

Thus, $(0, \frac{1}{6})$ is the y -intercept.

5. We find other function values to determine the general shape and then draw the graph.

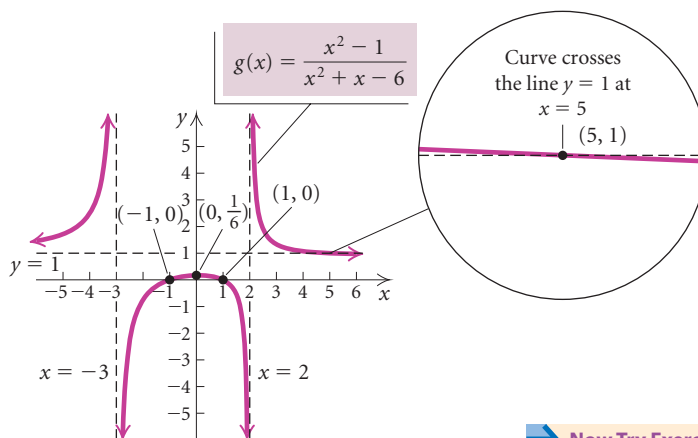

➔ Now Try Exercise 77.

The magnified portion of the graph in Example 9 above shows another situation in which a graph can cross its horizontal asymptote. The point where $g(x)$ crosses $y = 1$ can be found by setting $g(x) = 1$ and solving for x :

$$\begin{aligned} \frac{x^2 - 1}{x^2 + x - 6} &= 1 \\ x^2 - 1 &= x^2 + x - 6 && \text{Subtracting } x^2 \\ -1 &= x - 6 && \text{Subtracting } x^2 \\ 5 &= x && \text{Adding 6} \end{aligned}$$

The point of intersection is $(5, 1)$. Let's observe the behavior of the curve after it crosses the horizontal asymptote at $x = 5$. (See the graph at left.) It continues to decrease for a short interval and then begins to increase, getting closer and closer to $y = 1$ as $x \rightarrow \infty$.

Graphs of rational functions can also cross an oblique asymptote. The graph of

$$f(x) = \frac{2x^3}{x^2 + 1}$$

shown below crosses its oblique asymptote $y = 2x$. **Remember, graphs can cross horizontal asymptotes or oblique asymptotes, but they cannot cross vertical asymptotes.**

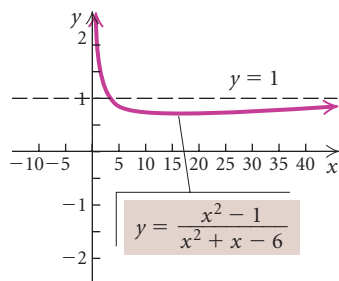
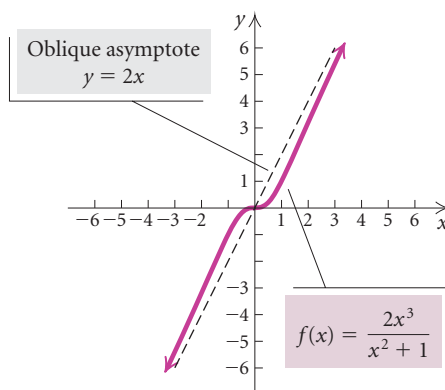

“Holes” in a Graph

Let's now graph a rational function $f(x) = p(x)/q(x)$, where $p(x)$ and $q(x)$ have a common factor.

EXAMPLE 10 Graph: $g(x) = \frac{x - 2}{x^2 - x - 2}$.

Solution We first express the denominator in factored form:

$$g(x) = \frac{x - 2}{x^2 - x - 2} = \frac{x - 2}{(x + 1)(x - 2)}$$

The domain of the function is $\{x \mid x \neq -1 \text{ and } x \neq 2\}$, or $(-\infty, -1) \cup (-1, 2) \cup (2, \infty)$. Note that the numerator and the denominator have the common factor $x - 2$. The zeros of the denominator are -1 and 2 , and the zero of the numerator is 2 . Since -1 is the only zero of the denominator that is *not* a zero of the numerator, the graph of the function has $x = -1$ as its *only* vertical asymptote. The degree of the numerator is less than the degree of the denominator, so $y = 0$ is the horizontal asymptote. There are no zeros of the function and thus no x -intercepts, because 2 is the only zero of the numerator and 2 is not in the domain of the function. Since $g(0) = 1$, $(0, 1)$ is the y -intercept.

The rational expression $(x - 2)/[(x + 1)(x - 2)]$ can be simplified. Thus,

$$g(x) = \frac{x - 2}{(x + 1)(x - 2)} = \frac{1}{x + 1}, \quad \text{where } x \neq -1 \text{ and } x \neq 2.$$

The graph of $g(x)$ is the graph of $y = 1/(x + 1)$ with the point where $x = 2$ missing. To determine the coordinates of the “hole,” we substitute 2 for x in $g(x) = 1/(x + 1)$:

$$g(2) = \frac{1}{2 + 1} = \frac{1}{3}.$$

Thus the “hole” is located at $(2, \frac{1}{3})$. We draw the graph indicating the “hole” when $x = 2$ with an open circle.

 **Now Try Exercise 49.**

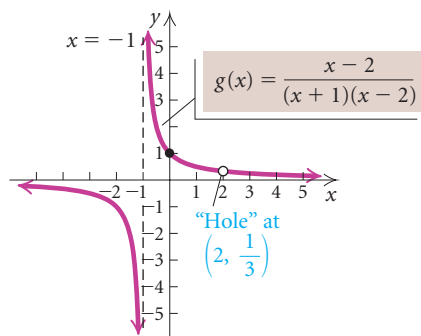

EXAMPLE 11 Graph: $f(x) = \frac{-2x^2 - x + 15}{x^2 - x - 12}$.

Solution We first express the numerator and the denominator in factored form:

$$f(x) = \frac{-2x^2 - x + 15}{x^2 - x - 12} = \frac{(-2x + 5)(x + 3)}{(x - 4)(x + 3)}$$

The domain of the function is $\{x \mid x \neq -3 \text{ and } x \neq 4\}$, or $(-\infty, -3) \cup (-3, 4) \cup (4, \infty)$. The numerator and the denominator have the common factor $x + 3$. The zeros of the denominator are -3 and 4 , and the zeros of the numerator are -3 and $\frac{5}{2}$. Since 4 is the only zero of the denominator that is *not* a zero of the numerator, the graph of the function has $x = 4$ as its *only* vertical asymptote.

The degrees of the numerator and the denominator are the same, so the line $y = \frac{-2}{1} = -2$ is the horizontal asymptote. The zeros of the numerator are $\frac{5}{2}$ and -3 . Because -3 is not in the domain of the function, the only x -intercept is $(\frac{5}{2}, 0)$. Since $f(0) = -\frac{15}{12} = -\frac{5}{4}$, then $(0, -\frac{5}{4})$ is the y -intercept.

The rational function $\frac{(-2x + 5)(x + 3)}{(x - 4)(x + 3)}$ can be simplified.

Thus,

$$f(x) = \frac{(-2x + 5)(x + 3)}{(x - 4)(x + 3)} = \frac{-2x + 5}{x - 4}, \text{ where } x \neq -3 \text{ and } x \neq 4.$$

The graph of $f(x)$ is the graph of $y = (-2x + 5)/(x - 4)$ with the point where $x = -3$ missing. To determine the coordinates of the “hole,” we substitute -3 for x in $f(x) = (-2x + 5)/(x - 4)$:

$$f(-3) = \frac{-2(-3) + 5}{-3 - 4} = \frac{11}{-7} = -\frac{11}{7}.$$

Thus the “hole” is located at $(-3, -\frac{11}{7})$. We draw the graph indicating the “hole” when $x = -3$ with an open circle.

x	y
-5	-1.67
-4	-1.63
-3	Not defined
-2	-1.5
-1	-1.4
0	-1.25
1	-1
2	-0.5
3	1
3.5	4
4	Not defined
5	-5
6	-3.5
7	-3
8	-2.75

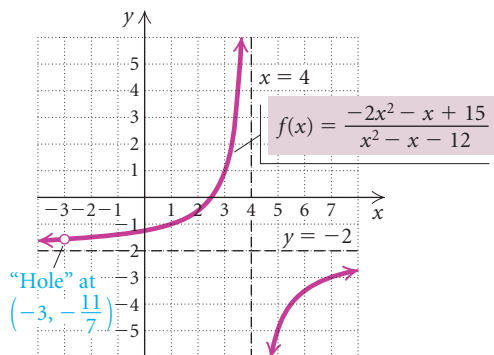

 Now Try Exercise 67.

► Applications

EXAMPLE 12 *Temperature During an Illness.* A person's temperature T , in degrees Fahrenheit, during an illness is given by the function

$$T(t) = \frac{4t}{t^2 + 1} + 98.6,$$

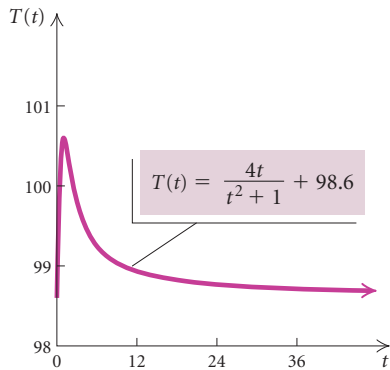

where time t is given in hours since the onset of the illness. The graph of this function is shown at left.

- Find the temperature at $t = 0, 1, 2, 5, 12,$ and 24 .
- Find the horizontal asymptote of the graph of $T(t)$. Complete:

$$T(t) \rightarrow \boxed{} \text{ as } t \rightarrow \infty.$$

- Give the meaning of the answer to part (b) in terms of the application.



Solution

- We have

$$\begin{aligned} T(0) &= 98.6, & T(1) &= 100.6, & T(2) &= 100.2, \\ T(5) &\approx 99.369, & T(12) &\approx 98.931, & \text{and } T(24) &\approx 98.766. \end{aligned}$$

- Since

$$\begin{aligned} T(t) &= \frac{4t}{t^2 + 1} + 98.6 \\ &= \frac{98.6t^2 + 4t + 98.6}{t^2 + 1}, \end{aligned}$$

the horizontal asymptote is $y = 98.6/1$, or 98.6 . Then it follows that $T(t) \rightarrow 98.6$ as $t \rightarrow \infty$.

- As time goes on, the temperature returns to “normal,” which is 98.6°F .

➔ **Now Try Exercise 83.**

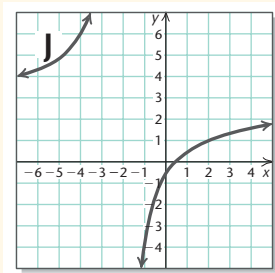
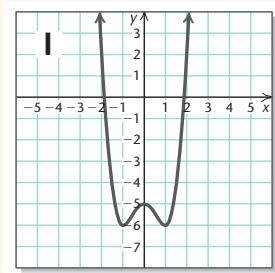
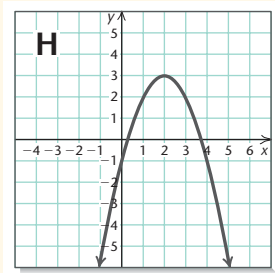
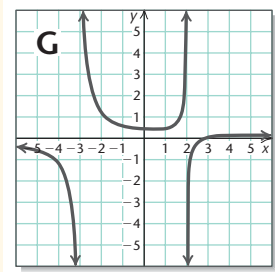
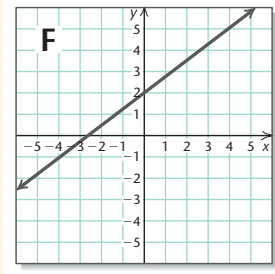
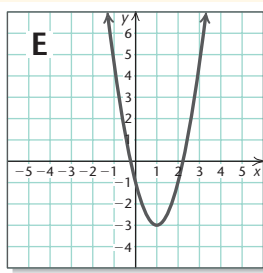
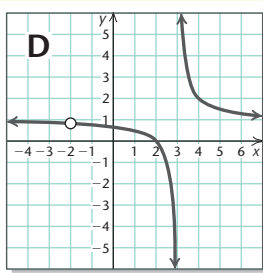
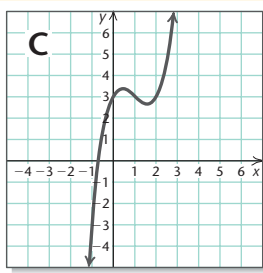
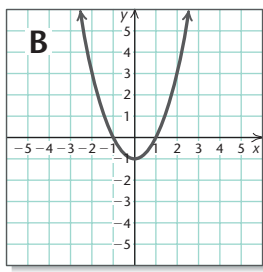
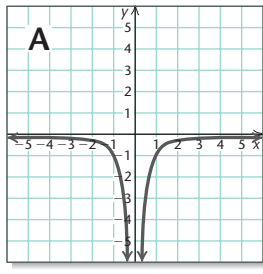

Visualizing the Graph

Match the function with its graph.

1. $f(x) = -\frac{1}{x^2}$
2. $f(x) = x^3 - 3x^2 + 2x + 3$
3. $f(x) = \frac{x^2 - 4}{x^2 - x - 6}$
4. $f(x) = -x^2 + 4x - 1$
5. $f(x) = \frac{x - 3}{x^2 + x - 6}$
6. $f(x) = \frac{3}{4}x + 2$
7. $f(x) = x^2 - 1$
8. $f(x) = x^4 - 2x^2 - 5$
9. $f(x) = \frac{8x - 4}{3x + 6}$
10. $f(x) = 2x^2 - 4x - 1$

Answers on page A-23

4.5

Exercise Set

Determine the domain of the function.

1. $f(x) = \frac{x^2}{2-x}$

2. $f(x) = \frac{1}{x^3}$

3. $f(x) = \frac{x+1}{x^2-6x+5}$

4. $f(x) = \frac{(x+4)^2}{4x-3}$

5. $f(x) = \frac{3x-4}{3x+15}$

6. $f(x) = \frac{x^2+3x-10}{x^2+2x}$

In Exercises 7–12, use your knowledge of asymptotes and intercepts to match the equation with one of the graphs (a)–(f), which follow. List all asymptotes.

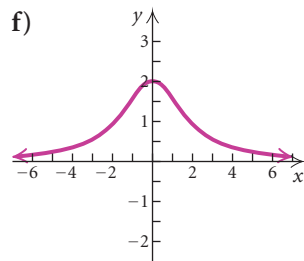
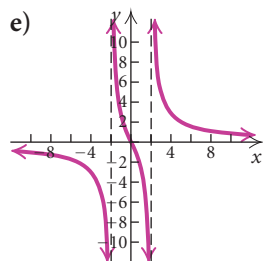
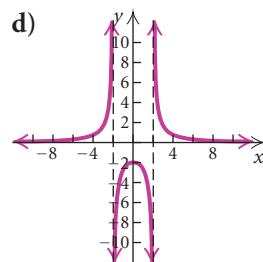
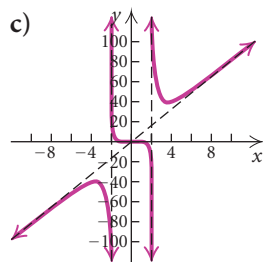
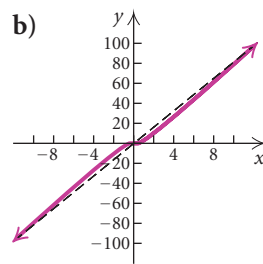
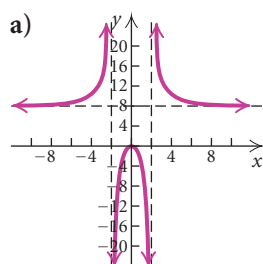

7. $f(x) = \frac{8}{x^2-4}$

8. $f(x) = \frac{8}{x^2+4}$

9. $f(x) = \frac{8x}{x^2-4}$

10. $f(x) = \frac{8x^2}{x^2-4}$

11. $f(x) = \frac{8x^3}{x^2-4}$

12. $f(x) = \frac{8x^3}{x^2+4}$

Determine the vertical asymptotes of the graph of the function.

13. $g(x) = \frac{1}{x^2}$

14. $f(x) = \frac{4x}{x^2+10x}$

15. $h(x) = \frac{x+7}{2-x}$

16. $g(x) = \frac{x^4+2}{x}$

17. $f(x) = \frac{3-x}{(x-4)(x+6)}$

18. $h(x) = \frac{x^2-4}{x(x+5)(x-2)}$

19. $g(x) = \frac{x^3}{2x^3-x^2-3x}$

20. $f(x) = \frac{x+5}{x^2+4x-32}$

Determine the horizontal asymptote of the graph of the function.

21. $f(x) = \frac{3x^2+5}{4x^2-3}$

22. $g(x) = \frac{x+6}{x^3+2x^2}$

23. $h(x) = \frac{x^2-4}{2x^4+3}$

24. $f(x) = \frac{x^5}{x^5+x}$

25. $g(x) = \frac{x^3-2x^2+x-1}{x^2-16}$

26. $h(x) = \frac{8x^4+x-2}{2x^4-10}$

Determine the oblique asymptote of the graph of the function.

27. $g(x) = \frac{x^2+4x-1}{x+3}$

28. $f(x) = \frac{x^2-6x}{x-5}$

29. $h(x) = \frac{x^4-2}{x^3+1}$

30. $g(x) = \frac{12x^3-x}{6x^2+4}$

31. $f(x) = \frac{x^3-x^2+x-4}{x^2+2x-1}$

32. $h(x) = \frac{5x^3-x^2+x-1}{x^2-x+2}$

Graph the function. Be sure to label all the asymptotes.
List the domain and the x - and y -intercepts.

33. $f(x) = \frac{1}{x}$

34. $g(x) = \frac{1}{x^2}$

35. $h(x) = -\frac{4}{x^2}$

36. $f(x) = -\frac{6}{x}$

37. $g(x) = \frac{x^2 - 4x + 3}{x + 1}$

38. $h(x) = \frac{2x^2 - x - 3}{x - 1}$

39. $f(x) = \frac{-2}{x - 5}$

40. $f(x) = \frac{1}{x - 5}$

41. $f(x) = \frac{2x + 1}{x}$

42. $f(x) = \frac{3x - 1}{x}$

43. $f(x) = \frac{x + 3}{x^2 - 9}$

44. $f(x) = \frac{x - 1}{x^2 - 1}$

45. $f(x) = \frac{x}{x^2 + 3x}$

46. $f(x) = \frac{3x}{3x - x^2}$

47. $f(x) = \frac{1}{(x - 2)^2}$

48. $f(x) = \frac{-2}{(x - 3)^2}$

49. $f(x) = \frac{x^2 + 2x - 3}{x^2 + 4x + 3}$

50. $f(x) = \frac{x^2 - x - 2}{x^2 - 5x - 6}$

51. $f(x) = \frac{1}{x^2 + 3}$

52. $f(x) = \frac{-1}{x^2 + 2}$

53. $f(x) = \frac{x^2 - 4}{x - 2}$

54. $f(x) = \frac{x^2 - 9}{x + 3}$

55. $f(x) = \frac{x - 1}{x + 2}$

56. $f(x) = \frac{x - 2}{x + 1}$

57. $f(x) = \frac{x^2 + 3x}{2x^3 - 5x^2 - 3x}$

58. $f(x) = \frac{3x}{x^2 + 5x + 4}$

59. $f(x) = \frac{x^2 - 9}{x + 1}$

60. $f(x) = \frac{x^3 - 4x}{x^2 - x}$

61. $f(x) = \frac{x^2 + x - 2}{2x^2 + 1}$

62. $f(x) = \frac{x^2 - 2x - 3}{3x^2 + 2}$

63. $g(x) = \frac{3x^2 - x - 2}{x - 1}$

64. $f(x) = \frac{2x^2 - 5x - 3}{2x + 1}$

65. $f(x) = \frac{x - 1}{x^2 - 2x - 3}$

66. $f(x) = \frac{x + 2}{x^2 + 2x - 15}$

67. $f(x) = \frac{3x^2 + 11x - 4}{x^2 + 2x - 8}$

68. $f(x) = \frac{2x^2 - 3x - 9}{x^2 - 2x - 3}$

69. $f(x) = \frac{x - 3}{(x + 1)^3}$

70. $f(x) = \frac{x + 2}{(x - 1)^3}$

71. $f(x) = \frac{x^3 + 1}{x}$

72. $f(x) = \frac{x^3 - 1}{x}$

73. $f(x) = \frac{x^3 + 2x^2 - 15x}{x^2 - 5x - 14}$

74. $f(x) = \frac{x^3 + 2x^2 - 3x}{x^2 - 25}$

75. $f(x) = \frac{5x^4}{x^4 + 1}$

76. $f(x) = \frac{x + 1}{x^2 + x - 6}$

77. $f(x) = \frac{x^2}{x^2 - x - 2}$

78. $f(x) = \frac{x^2 - x - 2}{x + 2}$

Find a rational function that satisfies the given conditions. Answers may vary, but try to give the simplest answer possible.

79. Vertical asymptotes $x = -4, x = 5$

80. Vertical asymptotes $x = -4, x = 5$; x -intercept $(-2, 0)$

81. Vertical asymptotes $x = -4, x = 5$; horizontal asymptote $y = \frac{3}{2}$; x -intercept $(-2, 0)$

82. Oblique asymptote $y = x - 1$

83. **Medical Dosage.** The function

$$N(t) = \frac{0.8t + 1000}{5t + 4}, \quad t \geq 15$$

gives the body concentration $N(t)$, in parts per million, of a certain dosage of medication after time t , in hours.

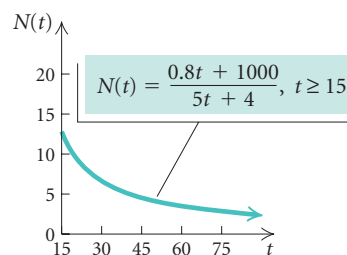

a) Find the horizontal asymptote of the graph and complete the following:

$$N(t) \rightarrow \boxed{} \text{ as } t \rightarrow \infty.$$

b) Explain the meaning of the answer to part (a) in terms of the application.

84. **Average Cost.** The average cost per disc, in dollars, for a company to produce x DVDs on exercising is given by the function

$$A(x) = \frac{2x + 100}{x}, \quad x > 0.$$

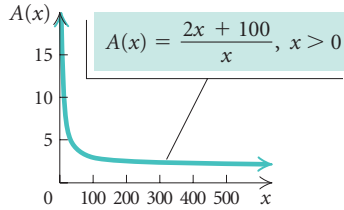

- a) Find the horizontal asymptote of the graph and complete the following:

$$A(x) \rightarrow \boxed{} \text{ as } x \rightarrow \infty.$$

- b) Explain the meaning of the answer to part (a) in terms of the application.

85. **Population Growth.** The population P , in thousands, of a resort community is given by

$$P(t) = \frac{500t}{2t^2 + 9},$$

where t is the time, in months.

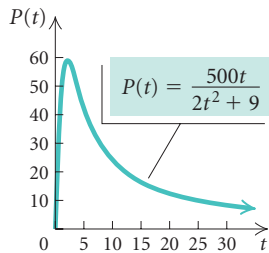

- a) Find the population at $t = 0, 1, 3,$ and 8 months.
 b) Find the horizontal asymptote of the graph and complete the following:

$$P(t) \rightarrow \boxed{} \text{ as } t \rightarrow \infty.$$

- c) Explain the meaning of the answer to part (b) in terms of the application.

Skill Maintenance

In each of Exercises 86–94, fill in the blank with the correct term. Some of the given choices will not be used. Others will be used more than once.

x -intercept	even function
y -intercept	domain
odd function	range

slope	slope–intercept
distance formula	equation
midpoint formula	difference
horizontal lines	quotient
vertical lines	$f(x) = f(-x)$
point–slope	$f(-x) = -f(x)$
equation	

86. A function is a correspondence between a first set, called the _____, and a second set, called the _____, such that each member of the _____ corresponds to exactly one member of the _____.
87. The _____ of a line containing (x_1, y_1) and (x_2, y_2) is given by $(y_2 - y_1)/(x_2 - x_1)$.
88. The _____ of the line with slope m and y -intercept $(0, b)$ is $y = mx + b$.
89. The _____ of the line with slope m passing through (x_1, y_1) is $y - y_1 = m(x - x_1)$.
90. A(n) _____ is a point $(a, 0)$.
91. For each x in the domain of an odd function f , _____.
92. _____ are given by equations of the type $x = a$.
93. The _____ is $\left(\frac{x_1 + x_2}{2}, \frac{y_1 + y_2}{2}\right)$.
94. A(n) _____ is a point $(0, b)$.

Synthesis

Find the nonlinear asymptote of the function.

95. $f(x) = \frac{x^5 + 2x^3 + 4x^2}{x^2 + 2}$

96. $f(x) = \frac{x^4 + 3x^2}{x^2 + 1}$

Graph the function.

97. $f(x) = \frac{2x^3 + x^2 - 8x - 4}{x^3 + x^2 - 9x - 9}$

98. $f(x) = \frac{x^3 + 4x^2 + x - 6}{x^2 - x - 2}$

Polynomial Inequalities and Rational Inequalities

4.6

- ▶ Solve polynomial inequalities.
- ▶ Solve rational inequalities.

We will use a combination of algebraic and graphical methods to solve polynomial inequalities and rational inequalities.

▶ Polynomial Inequalities

Just as a quadratic equation can be written in the form $ax^2 + bx + c = 0$, a **quadratic inequality** can be written in the form $ax^2 + bx + c \blacksquare 0$, where \blacksquare is $<$, $>$, \leq , or \geq . Here are some examples of quadratic inequalities:

$$x^2 - 4x - 5 < 0 \quad \text{and} \quad -\frac{1}{2}x^2 + 4x - 7 \geq 0.$$

When the inequality symbol in a polynomial inequality is replaced with an equals sign, a **related equation** is formed. Polynomial inequalities can be solved once the related equation has been solved.

EXAMPLE 1 Solve: $x^2 - 4x - 5 > 0$.

Solution We are asked to find all x -values for which $x^2 - 4x - 5 > 0$. To locate these values, we graph $f(x) = x^2 - 4x - 5$. Then we note that whenever its graph passes through an x -intercept, the function changes sign. Thus to solve $x^2 - 4x - 5 > 0$, we first solve the *related equation* $x^2 - 4x - 5 = 0$ to find all zeros of the function:

$$\begin{aligned} x^2 - 4x - 5 &= 0 \\ (x + 1)(x - 5) &= 0. \end{aligned}$$

The zeros are -1 and 5 . Thus the x -intercepts of the graph are $(-1, 0)$ and $(5, 0)$, as shown below.

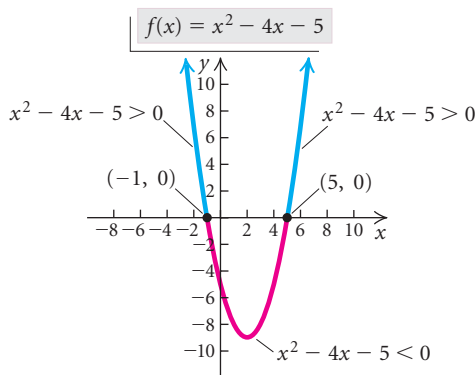

The zeros divide the x -axis into three intervals:

$$(-\infty, -1), \quad (-1, 5), \quad \text{and} \quad (5, \infty).$$



The sign of $x^2 - 4x - 5$ is the same for all values of x in a given interval. Thus we choose a test value for x from each interval and find $f(x)$. We can also determine the sign of $f(x)$ in each interval by simply looking at the graph of the function.

Interval	$(-\infty, -1)$	$(-1, 5)$	$(5, \infty)$
Test Value	$f(-2) = 7$	$f(0) = -5$	$f(7) = 16$
Sign of $f(x)$	Positive	Negative	Positive



Since we are solving $x^2 - 4x - 5 > 0$, the solution set consists of only two of the three intervals, those in which the sign of $f(x)$ is positive. Since the inequality sign is $>$, we do not include the endpoints of the intervals in the solution set. The solution set is

$$(-\infty, -1) \cup (5, \infty), \quad \text{or} \quad \{x \mid x < -1 \text{ or } x > 5\}.$$

Now Try Exercise 27.

EXAMPLE 2 Solve: $x^2 + 3x - 5 \leq x + 3$.

Solution By subtracting $x + 3$, we form an equivalent inequality:

$$\begin{aligned} x^2 + 3x - 5 - x - 3 &\leq 0 \\ x^2 + 2x - 8 &\leq 0. \end{aligned}$$

We need to find all x -values for which $x^2 + 2x - 8 \leq 0$. To visualize these values, we first graph $f(x) = x^2 + 2x - 8$ and then determine the zeros of the function. To find the zeros, we solve the related equation $x^2 + 2x - 8 = 0$:

$$\begin{aligned} x^2 + 2x - 8 &= 0 \\ (x + 4)(x - 2) &= 0. \end{aligned}$$

The zeros are -4 and 2 . Thus the x -intercepts of the graph are $(-4, 0)$ and $(2, 0)$, as shown in the figure at left.

The zeros divide the x -axis into three intervals:

$$(-\infty, -4), \quad (-4, 2), \quad \text{and} \quad (2, \infty).$$

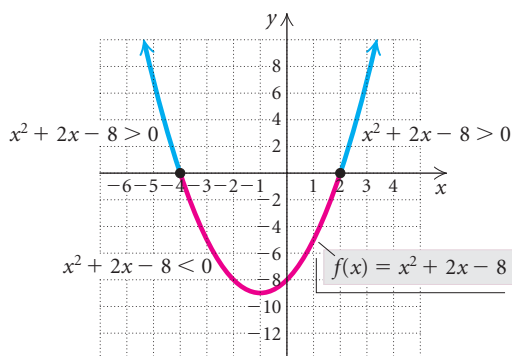

We choose a test value for x from each interval and find $f(x)$. The sign of $x^2 + 2x - 8$ is the same for all values of x in a given interval.

Interval	$(-\infty, -4)$	$(-4, 2)$	$(2, \infty)$
Test Value	$f(-5) = 7$	$f(0) = -8$	$f(4) = 16$
Sign of $f(x)$	Positive	Negative	Positive



Function values are negative on the interval $(-4, 2)$. We can also see in the graph where the function values are negative. Since the inequality symbol is \leq , we include the endpoints of the interval in the solution set. The solution set of $x^2 + 3x - 5 \leq x + 3$ is

$$[-4, 2], \text{ or } \{x \mid -4 \leq x \leq 2\}.$$

Now Try Exercise 29.

Quadratic inequalities are one type of **polynomial inequality**. Other examples of polynomial inequalities are

$$-2x^4 + x^2 - 3 < 7, \quad \frac{2}{3}x + 4 \geq 0, \quad \text{and} \quad 4x^3 - 2x^2 > 5x + 7.$$

EXAMPLE 3 Solve: $x^3 - x > 0$.

Solution We are asked to find all x -values for which $x^3 - x > 0$. To locate these values, we graph $f(x) = x^3 - x$. Then we note that whenever the function changes sign, its graph passes through an x -intercept. Thus to solve $x^3 - x > 0$, we first solve the related equation $x^3 - x = 0$ to find all zeros of the function:

$$\begin{aligned} x^3 - x &= 0 \\ x(x^2 - 1) &= 0 \\ x(x + 1)(x - 1) &= 0. \end{aligned}$$

The zeros are -1 , 0 , and 1 . Thus the x -intercepts of the graph are $(-1, 0)$, $(0, 0)$, and $(1, 0)$, as shown in the figure at left. The zeros divide the x -axis into four intervals:

$$(-\infty, -1), \quad (-1, 0), \quad (0, 1), \quad \text{and} \quad (1, \infty).$$



The sign of $x^3 - x$ is the same for all values of x in a given interval. Thus we choose a test value for x from each interval and find $f(x)$. We can also determine the sign of $f(x)$ in each interval by simply looking at the graph of the function.

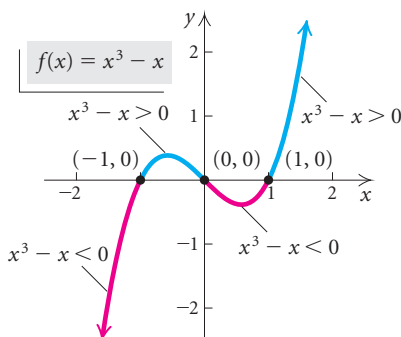

Interval	$(-\infty, -1)$	$(-1, 0)$	$(0, 1)$	$(1, \infty)$
Test Value	$f(-2) = -6$	$f(-0.5) = 0.375$	$f(0.5) = -0.375$	$f(2) = 6$
Sign of $f(x)$	Negative	Positive	Negative	Positive



Since we are solving $x^3 - x > 0$, the solution set consists of only two of the four intervals, those in which the sign of $f(x)$ is *positive*. We see that the solution set is $(-1, 0) \cup (1, \infty)$, or $\{x \mid -1 < x < 0 \text{ or } x > 1\}$.

 **Now Try Exercise 39.**

To solve a polynomial inequality:

1. Find an equivalent inequality with $P(x)$ on one side and 0 on the other.
2. Change the inequality symbol to an equals sign and solve the related equation; that is, solve $P(x) = 0$.
3. Use the solutions to divide the x -axis into intervals. Then select a test value from each interval and determine the polynomial's sign on the interval.
4. Determine the intervals for which the inequality is satisfied and write interval notation or set-builder notation for the solution set. Include the endpoints of the intervals in the solution set if the inequality symbol is \leq or \geq .

EXAMPLE 4 Solve: $3x^4 + 10x \leq 11x^3 + 4$.

Solution By subtracting $11x^3 + 4$, we form the equivalent inequality

$$3x^4 - 11x^3 + 10x - 4 \leq 0.$$

Algebraic Solution

To solve the related equation

$$3x^4 - 11x^3 + 10x - 4 = 0,$$

we need to use the theorems of Section 4.4. We solved this equation in Example 5 in Section 4.4. The solutions are

$$-1, \quad 2 - \sqrt{2}, \quad \frac{2}{3}, \quad \text{and} \quad 2 + \sqrt{2},$$

or approximately

$$-1, \quad 0.586, \quad 0.667, \quad \text{and} \quad 3.414.$$

These numbers divide the x -axis into five intervals:

$$(-\infty, -1), \quad (-1, 2 - \sqrt{2}), \quad (2 - \sqrt{2}, \frac{2}{3}),$$

$$(\frac{2}{3}, 2 + \sqrt{2}), \quad \text{and} \quad (2 + \sqrt{2}, \infty).$$

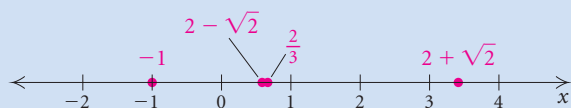

We then let $f(x) = 3x^4 - 11x^3 + 10x - 4$ and, using test values for $f(x)$, determine the sign of $f(x)$ in each interval.

INTERVAL	TEST VALUE	SIGN OF $f(x)$
$(-\infty, -1)$	$f(-2) = 112$	+
$(-1, 2 - \sqrt{2})$	$f(0) = -4$	-
$(2 - \sqrt{2}, \frac{2}{3})$	$f(0.6) = 0.0128$	+
$(\frac{2}{3}, 2 + \sqrt{2})$	$f(1) = -2$	-
$(2 + \sqrt{2}, \infty)$	$f(4) = 100$	+

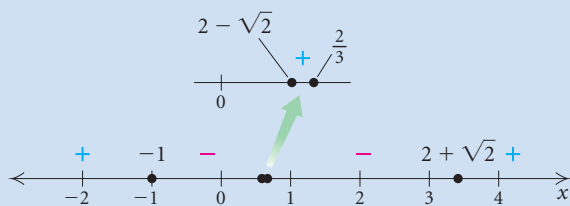

Function values are negative in the intervals $(-1, 2 - \sqrt{2})$ and $(\frac{2}{3}, 2 + \sqrt{2})$. Since the inequality sign is \leq , we include the endpoints of the intervals in the solution set. The solution set is

$$[-1, 2 - \sqrt{2}] \cup [\frac{2}{3}, 2 + \sqrt{2}], \quad \text{or}$$

$$\{x \mid -1 \leq x \leq 2 - \sqrt{2} \text{ or } \frac{2}{3} \leq x \leq 2 + \sqrt{2}\}.$$

Visualizing the Solution

Observing the graph of the function

$$f(x) = 3x^4 - 11x^3 + 10x - 4$$

and a closeup view of the graph on the interval $(0, 1)$, we see the intervals on which $f(x) \leq 0$. The values of $f(x)$ are less than or equal to 0 in two intervals.

$$f(x) = 3x^4 - 11x^3 + 10x - 4$$

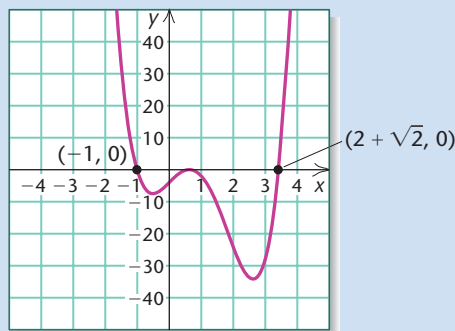

$$f(x) = 3x^4 - 11x^3 + 10x - 4$$

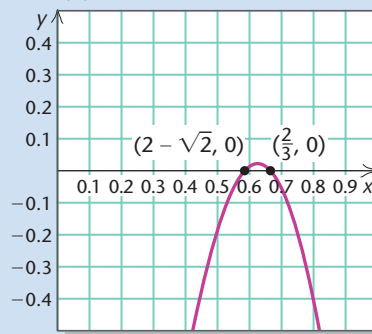

The solution set of the inequality

$$3x^4 - 11x^3 + 10x - 4 \leq 0$$

is

$$[-1, 2 - \sqrt{2}] \cup [\frac{2}{3}, 2 + \sqrt{2}].$$

TECHNOLOGY CONNECTION

Polynomial inequalities can be solved quickly with a graphing calculator. Consider the inequality in Example 4:

$$3x^4 + 10x \leq 11x^3 + 4, \quad \text{or}$$

$$3x^4 - 11x^3 + 10x - 4 \leq 0.$$

We graph the related equation

$$y = 3x^4 - 11x^3 + 10x - 4$$

and use the ZERO feature. We see in the window on the left below that two of the zeros are -1 and approximately 3.414 ($2 + \sqrt{2} \approx 3.414$). However, this window leaves us uncertain about the number of zeros of the function on the interval $[0, 1]$.

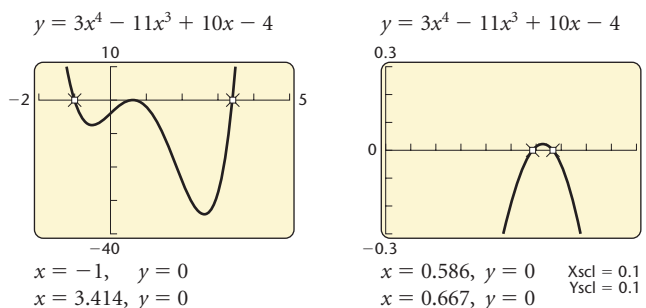

The window on the right above shows another view of the zeros on the interval $[0, 1]$. Those zeros are about 0.586 and 0.667 ($2 - \sqrt{2} \approx 0.586$; $\frac{2}{3} \approx 0.667$). The intervals to be considered are $(-\infty, -1)$, $(-1, 0.586)$, $(0.586, 0.667)$, $(0.667, 3.414)$, and $(3.414, \infty)$. We note on the graph where the function is negative. Then, including appropriate endpoints, we find that the solution set is approximately

$$[-1, 0.586] \cup [0.667, 3.414], \quad \text{or}$$

$$\{x \mid -1 \leq x \leq 0.586 \text{ or } 0.667 \leq x \leq 3.414\}.$$

► Rational Inequalities

Some inequalities involve rational expressions and functions. These are called **rational inequalities**. To solve rational inequalities, we need to make some adjustments to the preceding method.

EXAMPLE 5 Solve: $\frac{3x}{x+6} < 0$.

Solution We look for all values of x for which the related function

$$f(x) = \frac{3x}{x+6}$$

is not defined or is 0. These are called **critical values**.

The denominator tells us that $f(x)$ is not defined when $x = -6$. Next, we solve $f(x) = 0$:

$$\begin{aligned}\frac{3x}{x+6} &= 0 \\ (x+6) \cdot \frac{3x}{x+6} &= (x+6) \cdot 0 \\ 3x &= 0 \\ x &= 0.\end{aligned}$$

The critical values are -6 and 0 . These values divide the x -axis into three intervals:

$$(-\infty, -6), \quad (-6, 0), \quad \text{and} \quad (0, \infty).$$

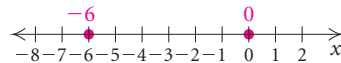

We then use a test value to determine the sign of $f(x)$ in each interval.

Interval	$(-\infty, -6)$	$(-6, 0)$	$(0, \infty)$
Test Value	$f(-8) = 12$	$f(-2) = -\frac{3}{2}$	$f(3) = 1$
Sign of $f(x)$	Positive	Negative	Positive

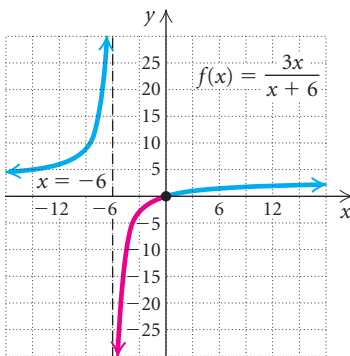

Function values are negative on only the interval $(-6, 0)$. Since $f(0) = 0$ and the inequality symbol is $<$, we know that 0 is not included in the solution set. Note that since -6 is not in the domain of f , -6 cannot be part of the solution set. The solution set is

$$(-6, 0), \quad \text{or} \quad \{x \mid -6 < x < 0\}.$$

The graph of $f(x)$ shows where $f(x)$ is positive and where it is negative.

Now Try Exercise 57.

EXAMPLE 6 Solve: $\frac{x-3}{x+4} \geq \frac{x+2}{x-5}$.

Solution We first subtract $(x+2)/(x-5)$ on both sides in order to find an equivalent inequality with 0 on one side:

$$\frac{x-3}{x+4} - \frac{x+2}{x-5} \geq 0.$$

Algebraic Solution

We look for all values of x for which the related function

$$f(x) = \frac{x-3}{x+4} - \frac{x+2}{x-5}$$

is not defined or is 0. These are called **critical values**.

A look at the denominators shows that $f(x)$ is not defined for $x = -4$ and $x = 5$. Next, we solve $f(x) = 0$:

$$\frac{x-3}{x+4} - \frac{x+2}{x-5} = 0$$

$$(x+4)(x-5)\left(\frac{x-3}{x+4} - \frac{x+2}{x-5}\right) = (x+4)(x-5) \cdot 0$$

$$(x-5)(x-3) - (x+4)(x+2) = 0$$

$$(x^2 - 8x + 15) - (x^2 + 6x + 8) = 0$$

$$-14x + 7 = 0$$

$$x = \frac{1}{2}$$

The critical values are -4 , $\frac{1}{2}$, and 5 . These values divide the x -axis into four intervals:

$$(-\infty, -4), \quad \left(-4, \frac{1}{2}\right), \quad \left(\frac{1}{2}, 5\right), \quad \text{and} \quad (5, \infty).$$

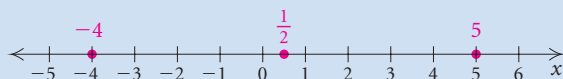

We then use a test value to determine the sign of $f(x)$ in each interval.

INTERVAL	TEST VALUE	SIGN OF $f(x)$
$(-\infty, -4)$	$f(-5) = 7.7$	+
$\left(-4, \frac{1}{2}\right)$	$f(-2) = -2.5$	-
$\left(\frac{1}{2}, 5\right)$	$f(3) = 2.5$	+
$(5, \infty)$	$f(6) = -7.7$	-

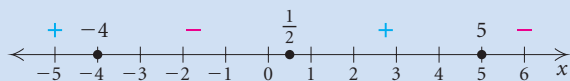

Function values are positive in the intervals $(-\infty, -4)$ and $\left(\frac{1}{2}, 5\right)$. Since $f\left(\frac{1}{2}\right) = 0$ and the inequality symbol is \geq , we know that $\frac{1}{2}$ must be in the solution set. Note that since neither -4 nor 5 is in the domain of f , they cannot be part of the solution set.

The solution set is $(-\infty, -4) \cup \left[\frac{1}{2}, 5\right)$.

Visualizing the Solution

The graph of the related function

$$f(x) = \frac{x-3}{x+4} - \frac{x+2}{x-5}$$

confirms the three critical values found algebraically: -4 and 5 where $f(x)$ is not defined and $\frac{1}{2}$ where $f(x) = 0$.

$$f(x) = \frac{x-3}{x+4} - \frac{x+2}{x-5}$$

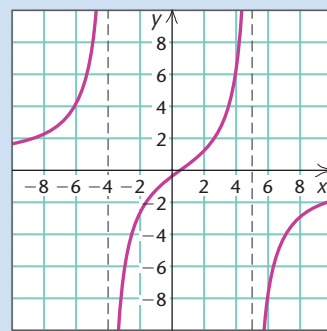

The graph shows where $f(x)$ is positive and where it is negative. Note that -4 and 5 cannot be in the solution set since $f(x)$ is not defined for these values. We do include $\frac{1}{2}$, however, since the inequality symbol is \geq and $f\left(\frac{1}{2}\right) = 0$. The solution set is

$$(-\infty, -4) \cup \left[\frac{1}{2}, 5\right)$$

The following is a method for solving rational inequalities.

To solve a rational inequality:

1. Find an equivalent inequality with 0 on one side.
2. Change the inequality symbol to an equals sign and solve the related equation.
3. Find values of the variable for which the related rational function is not defined.
4. The numbers found in steps (2) and (3) are called critical values. Use the critical values to divide the x -axis into intervals. Then determine the function's sign in each interval using an x -value from the interval or the graph of the equation.
5. Select the intervals for which the inequality is satisfied and write interval notation or set-builder notation for the solution set. If the inequality symbol is \leq or \geq , then the solutions to step (2) should be included in the solution set. The x -values found in step (3) are never included in the solution set.

It works well to use a combination of algebraic and graphical methods to solve polynomial inequalities and rational inequalities. The algebraic methods give exact numbers for the critical values, and the graphical methods usually allow us to see easily what intervals satisfy the inequality.

4.6

Exercise Set

For the function $f(x) = x^2 + 2x - 15$, solve each of the following.

1. $f(x) = 0$
2. $f(x) < 0$
3. $f(x) \leq 0$
4. $f(x) > 0$
5. $f(x) \geq 0$

For the function $g(x) = \frac{x-2}{x+4}$, solve each of the following.

6. $g(x) = 0$
7. $g(x) > 0$
8. $g(x) \leq 0$
9. $g(x) \geq 0$
10. $g(x) < 0$

For the function

$$h(x) = \frac{7x}{(x-1)(x+5)},$$

solve each of the following.

11. $h(x) = 0$
12. $h(x) \leq 0$
13. $h(x) \geq 0$

14. $h(x) > 0$

15. $h(x) < 0$

For the function $g(x) = x^5 - 9x^3$, solve each of the following.

16. $g(x) = 0$

17. $g(x) < 0$

18. $g(x) \leq 0$

19. $g(x) > 0$

20. $g(x) \geq 0$

In Exercises 21–24, a related function is graphed. Solve the given inequality.

21. $x^3 + 6x^2 < x + 30$

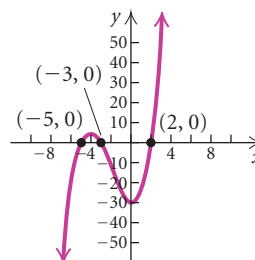

22. $x^4 - 27x^2 - 14x + 120 \geq 0$

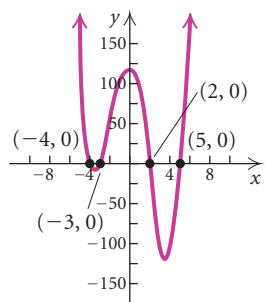

23. $\frac{8x}{x^2 - 4} \geq 0$

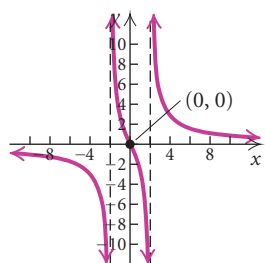

24. $\frac{8}{x^2 - 4} < 0$

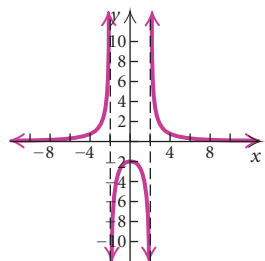

Solve.

25. $(x - 1)(x + 4) < 0$

26. $(x + 3)(x - 5) < 0$

27. $x^2 + x - 2 > 0$

28. $x^2 - x - 6 > 0$

29. $x^2 - x - 5 \geq x - 2$

30. $x^2 + 4x + 7 \geq 5x + 9$

31. $x^2 > 25$

32. $x^2 \leq 1$

33. $4 - x^2 \leq 0$

34. $11 - x^2 \geq 0$

35. $6x - 9 - x^2 < 0$

36. $x^2 + 2x + 1 \leq 0$

37. $x^2 + 12 < 4x$

38. $x^2 - 8 > 6x$

39. $4x^3 - 7x^2 \leq 15x$

40. $2x^3 - x^2 < 5x$

41. $x^3 + 3x^2 - x - 3 \geq 0$

42. $x^3 + x^2 - 4x - 4 \geq 0$

43. $x^3 - 2x^2 < 5x - 6$

44. $x^3 + x \leq 6 - 4x^2$

45. $x^5 + x^2 \geq 2x^3 + 2$

46. $x^5 + 24 > 3x^3 + 8x^2$

47. $2x^3 + 6 \leq 5x^2 + x$

48. $2x^3 + x^2 < 10 + 11x$

49. $x^3 + 5x^2 - 25x \leq 125$

50. $x^3 - 9x + 27 \geq 3x^2$

51. $0.1x^3 - 0.6x^2 - 0.1x + 2 < 0$

52. $19.2x^3 + 12.8x^2 + 144 \geq 172.8x + 3.2x^4$

List the critical values of the related function. Then solve the inequality.

53. $\frac{1}{x + 4} > 0$

54. $\frac{1}{x - 3} \leq 0$

55. $\frac{-4}{2x + 5} < 0$

56. $\frac{-2}{5 - x} \geq 0$

57. $\frac{2x}{x - 4} \geq 0$

58. $\frac{5x}{x + 1} < 0$

59. $\frac{x - 4}{x + 3} - \frac{x + 2}{x - 1} \leq 0$

60. $\frac{x + 1}{x - 2} - \frac{x - 3}{x - 1} < 0$

61. $\frac{x + 6}{x - 2} > \frac{x - 8}{x - 5}$

62. $\frac{x - 7}{x + 2} \geq \frac{x - 9}{x + 3}$

63. $\frac{x + 1}{x - 2} \geq 3$

64. $\frac{x}{x - 5} < 2$

65. $x - 2 > \frac{1}{x}$

66. $4 \geq \frac{4}{x} + x$

67.
$$\frac{2}{x^2 - 4x + 3} \leq \frac{5}{x^2 - 9}$$

68.
$$\frac{3}{x^2 - 4} \leq \frac{5}{x^2 + 7x + 10}$$

69.
$$\frac{3}{x^2 + 1} \geq \frac{6}{5x^2 + 2}$$

70.
$$\frac{4}{x^2 - 9} < \frac{3}{x^2 - 25}$$

71.
$$\frac{5}{x^2 + 3x} < \frac{3}{2x + 1}$$

72.
$$\frac{2}{x^2 + 3} > \frac{3}{5 + 4x^2}$$

73.
$$\frac{5x}{7x - 2} > \frac{x}{x + 1}$$

74.
$$\frac{x^2 - x - 2}{x^2 + 5x + 6} < 0$$

75.
$$\frac{x}{x^2 + 4x - 5} + \frac{3}{x^2 - 25} \leq \frac{2x}{x^2 - 6x + 5}$$

76.
$$\frac{2x}{x^2 - 9} + \frac{x}{x^2 + x - 12} \geq \frac{3x}{x^2 + 7x + 12}$$

- 77.
- Temperature During an Illness.**
- A person's temperature
- T
- , in degrees Fahrenheit, during an illness is given by the function

$$T(t) = \frac{4t}{t^2 + 1} + 98.6,$$

where t is the time since the onset of the illness, in hours. Find the interval on which the temperature was over 100°F . (See Example 12 in Section 4.5.)

- 78.
- Population Growth.**
- The population
- P
- , in thousands, of a resort community is given by

$$P(t) = \frac{500t}{2t^2 + 9},$$

where t is the time, in months. Find the interval on which the population was 40,000 or greater. (See Exercise 85 in Exercise Set 4.5.)

- 79.
- Total Profit.**
- Flexl, Inc., determines that its total profit is given by the function

$$P(x) = -3x^2 + 630x - 6000.$$

- a) Flexl makes a profit for those nonnegative values of x for which $P(x) > 0$. Find the values of x for which Flexl makes a profit.
- b) Flexl loses money for those nonnegative values of x for which $P(x) < 0$. Find the values of x for which Flexl loses money.
80. **Height of a Thrown Object.** The function

$$S(t) = -16t^2 + 32t + 1920$$

gives the height S , in feet, of an object thrown upward from a cliff that is 1920 ft high. Here t is the time, in seconds, that the object is in the air.

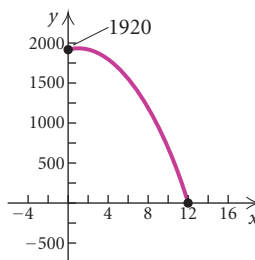

- a) For what times is the height greater than 1920 ft?
- b) For what times is the height less than 640 ft?
81. **Number of Diagonals.** A polygon with n sides has D diagonals, where D is given by the function

$$D(n) = \frac{n(n-3)}{2}.$$

Find the number of sides n if

$$27 \leq D \leq 230.$$

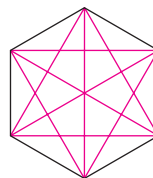

- 82.
- Number of Handshakes.**
- If there are
- n
- people in a room, the number
- N
- of possible handshakes by all the people in the room is given by the function

$$N(n) = \frac{n(n-1)}{2}.$$

For what number n of people is

$$66 \leq N \leq 300?$$

Skill Maintenance

Find an equation for a circle satisfying the given conditions.

83. Center:
- $(-2, 4)$
- ; radius of length 3

84. Center:
- $(0, -3)$
- ; diameter of length
- $\frac{7}{2}$

In Exercises 85 and 86:

- Find the vertex.
- Determine whether there is a maximum or minimum value and find that value.
- Find the range.

85. $h(x) = -2x^2 + 3x - 8$

86. $g(x) = x^2 - 10x + 2$

Synthesis

Solve.

87. $|x^2 - 5| = 5 - x^2$

88. $x^4 - 6x^2 + 5 > 0$

89. $2|x|^2 - |x| + 2 \leq 5$

90. $(7 - x)^{-2} < 0$

91. $\left| 1 + \frac{1}{x} \right| < 3$

92. $\left| 2 - \frac{1}{x} \right| \leq 2 + \left| \frac{1}{x} \right|$

93. Write a quadratic inequality for which the solution set is $(-4, 3)$.

94. Write a polynomial inequality for which the solution set is $[-4, 3] \cup [7, \infty)$.

Find the domain of the function.

95. $f(x) = \sqrt{\frac{72}{x^2 - 4x - 21}}$

96. $f(x) = \sqrt{x^2 - 4x - 21}$

Chapter 4 Summary and Review

STUDY GUIDE

KEY TERMS AND CONCEPTS

EXAMPLES

SECTION 4.1: POLYNOMIAL FUNCTIONS AND MODELS

Polynomial Function

$$P(x) = a_n x^n + a_{n-1} x^{n-1} + a_{n-2} x^{n-2} + \cdots + a_1 x + a_0,$$

where the coefficients $a_n, a_{n-1}, \dots, a_1, a_0$ are real numbers and the exponents are whole numbers.

The first nonzero coefficient, a_n , is called the **leading coefficient**. The term $a_n x^n$ is called the **leading term**. The **degree** of the polynomial function is n .

Classifying polynomial functions by degree:

Type	Degree
Constant	0
Linear	1
Quadratic	2
Cubic	3
Quartic	4

The Leading-Term Test

If $a_n x^n$ is the leading term of a polynomial function, then the behavior of the graph as $x \rightarrow \infty$ and as $x \rightarrow -\infty$ can be described in one of the four following ways.

a) If n is even, and $a_n > 0$:



b) If n is even, and $a_n < 0$:



c) If n is odd, and $a_n > 0$:



d) If n is odd, and $a_n < 0$:

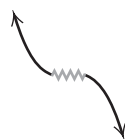

Consider the polynomial

$$P(x) = \frac{1}{3}x^2 + x - 4x^5 + 2.$$

Leading term: $-4x^5$

Leading coefficient: -4

Degree of polynomial: 5

Classify the following polynomial functions:

Function	Type
$f(x) = -2$	Constant
$f(x) = 0.6x - 11$	Linear
$f(x) = 5x^2 + x - 4$	Quadratic
$f(x) = 5x^3 - x + 10$	Cubic
$f(x) = -x^4 + 8x^3 + x$	Quartic

Using the leading-term test, describe the end behavior of the graph of each function by selecting one of (a)–(d) shown at left.

$$h(x) = -2x^6 + x^4 - 3x^2 + x$$

The leading term $a_n x^n$ is $-2x^6$. Since 6 is even and $-2 < 0$, the shape is shown in (b).

$$g(x) = 4x^3 - 8x + 1$$

The leading term, $a_n x^n$, is $4x^3$. Since 3 is odd and $4 > 0$, the shape is shown in (c).

Zeros of Functions

If c is a real zero of a function $f(x)$ (that is, $f(c) = 0$), then $x - c$ is a factor of $f(x)$ and $(c, 0)$ is an x -intercept of the graph of the function.

If we know the linear factors of a polynomial function $f(x)$, we can find the zeros of $f(x)$ by solving the equation $f(x) = 0$ using the principle of zero products.

Every function of degree n , with $n \geq 1$, has at least one zero and at most n zeros.

To find the zeros of

$$f(x) = -2(x - 3)(x + 8)^2,$$

solve $-2(x - 3)(x + 8)^2 = 0$ using the principle of zero products:

$$x - 3 = 0 \quad \text{or} \quad x + 8 = 0$$

$$x = 3 \quad \text{or} \quad x = -8.$$

The zeros of $f(x)$ are 3 and -8 .

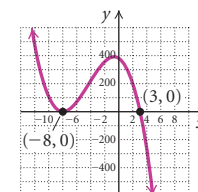

$$f(x) = -2(x - 3)(x + 8)^2$$

To find the zeros of

$$h(x) = x^4 - 12x^2 - 64,$$

solve $h(x) = 0$:

$$x^4 - 12x^2 - 64 = 0$$

$$(x^2 - 16)(x^2 + 4) = 0$$

$$(x + 4)(x - 4)(x^2 + 4) = 0$$

$$x + 4 = 0 \quad \text{or} \quad x - 4 = 0 \quad \text{or} \quad x^2 + 4 = 0$$

$$x = -4 \quad \text{or} \quad x = 4 \quad \text{or} \quad x^2 = -4$$

$$= \pm\sqrt{-4}$$

$$= \pm 2i.$$

The zeros of $h(x)$ are -4 , 4 , and $\pm 2i$.

Even and Odd Multiplicity

If $(x - c)^k$, $k \geq 1$, is a factor of a polynomial function $P(x)$ and $(x - c)^{k+1}$ is not a factor and:

- k is odd, then the graph crosses the x -axis at $(c, 0)$;
- k is even, then the graph is tangent to the x -axis at $(c, 0)$.

For $f(x) = -2(x - 3)(x + 8)^2$ graphed above, note that for the factor $x - 3$, or $(x - 3)^1$, the exponent 1 is odd and the graph crosses the x -axis at $(3, 0)$. For the factor $(x + 8)^2$, the exponent 2 is even and the graph is tangent to the x -axis at $(-8, 0)$.

SECTION 4.2: GRAPHING POLYNOMIAL FUNCTIONS

If $P(x)$ is a polynomial function of degree n , the graph of the function has:

- at most n real zeros, and thus at most n x -intercepts, and
- at most $n - 1$ turning points.

To Graph a Polynomial Function

1. Use the leading-term test to determine the end behavior.
2. Find the zeros of the function by solving $f(x) = 0$. Any real zeros are the first coordinates of the x -intercepts.

Graph: $h(x) = x^4 - 12x^2 - 16x = x(x - 4)(x + 2)^2$.

1. The leading term is x^4 . Since 4 is even and $1 > 0$, the end behavior of the graph can be sketched as follows.



2. Solve $x(x - 4)(x + 2)^2 = 0$. The solutions are 0, 4, and -2 . The zeros of $h(x)$ are 0, 4, and -2 . The x -intercepts are $(0, 0)$, $(4, 0)$, and $(-2, 0)$. The multiplicity of 0 and 4 is 1. The graph will cross the x -axis at 0 and 4. The multiplicity of -2 is 2. The graph is tangent to the x -axis at -2 .

(Continued)

- Use the x -intercepts (zeros) to divide the x -axis into intervals and choose a test point in each interval to determine the sign of all function values in that interval. For all x -values in an interval, $f(x)$ is either always positive for all values or always negative for all values.
- Find $f(0)$. This gives the y -intercept of the function.
- If necessary, find additional function values to determine the general shape of the graph and then draw the graph.

- The zeros divide the x -axis into four intervals.

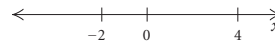

Interval	$(-\infty, -2)$	$(-2, 0)$	$(0, 4)$	$(4, \infty)$
Test Value	-3	-1	1	5
Function Value, $h(x)$	21	5	-27	245
Sign of $h(x)$	+	+	-	+
Location of Points on Graph	Above x -axis	Above x -axis	Below x -axis	Above x -axis

Four points on the graph are $(-3, 21)$, $(-1, 5)$, $(1, -27)$, and $(5, 245)$.

- Find $h(0)$:

$$h(0) = 0(0 - 4)(0 + 2)^2 = 0.$$

The y -intercept is $(0, 0)$.

- Find additional points and draw the graph.

x	$h(x)$
-2.5	4.1
-1.5	2.1
-0.5	5.1
0.5	-10.9
2	-64
3	-75

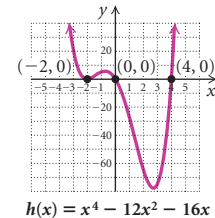

The Intermediate Value Theorem

For any polynomial function $P(x)$ with real coefficients, suppose that for $a \neq b$, $P(a)$ and $P(b)$ are of opposite signs. Then the function has at least one real zero between a and b .

The intermediate value theorem *cannot* be used to determine whether there is a real zero between a and b when $P(a)$ and $P(b)$ have the *same* sign.

Use the intermediate value theorem to determine, if possible, whether the function has a zero between a and b .

$$f(x) = 2x^3 - 5x^2 + x - 2, \quad a = 2, b = 3;$$

$$f(2) = -4; \quad f(3) = 10$$

Since $f(2)$ and $f(3)$ have opposite signs, $f(x)$ has at least one zero between 2 and 3.

$$f(x) = 2x^3 - 5x^2 + x - 2, \quad a = -2, b = -1;$$

$$f(-2) = -40; \quad f(-1) = -10$$

Both $f(-2)$ and $f(-1)$ are negative. Thus the intermediate value theorem does not allow us to determine whether there is a real zero between -2 and -1 .

SECTION 4.3: POLYNOMIAL DIVISION; THE REMAINDER THEOREM AND THE FACTOR THEOREM
Polynomial Division

$$P(x) = d(x) \cdot Q(x) + R(x)$$

↖ ↖ ↖ ↖
Dividend Divisor Quotient Remainder

When we divide a polynomial $P(x)$ by a divisor $d(x)$, a polynomial $Q(x)$ is the quotient and a polynomial $R(x)$ is the remainder. The quotient $Q(x)$ must have degree less than that of the dividend $P(x)$. The remainder $R(x)$ must either be 0 or have degree less than that of the divisor $d(x)$. If $R(x) = 0$, then the divisor $d(x)$ is a factor of the dividend.

The Remainder Theorem

If a number c is substituted for x in the polynomial $f(x)$, then the result $f(c)$ is the remainder that would be obtained by dividing $f(x)$ by $x - c$. That is, if $f(x) = (x - c) \cdot Q(x) + R$, then $f(c) = R$.

The long-division process can be streamlined with synthetic division. Synthetic division also can be used to find polynomial function values.

Given $P(x) = x^4 - 6x^3 + 9x^2 + 4x - 12$ and $d(x) = x + 2$, use long division to find the quotient and the remainder when $P(x)$ is divided by $d(x)$. Express $P(x)$ in the form $d(x) \cdot Q(x) + R(x)$.

$$\begin{array}{r}
 x^3 - 8x^2 + 25x - 46 \\
 x + 2 \overline{) x^4 - 6x^3 + 9x^2 + 4x - 12} \\
 \underline{x^4 + 2x^3} \\
 -8x^3 + 9x^2 \\
 \underline{-8x^3 - 16x^2} \\
 25x^2 + 4x - 12 \\
 \underline{25x^2 + 50x} \\
 -46x - 12 \\
 \underline{-46x - 92} \\
 80
 \end{array}$$

$Q(x) = x^3 - 8x^2 + 25x - 46$ and $R(x) = 80$. Thus, $P(x) = (x + 2)(x^3 - 8x^2 + 25x - 46) + 80$. Since $R(x) \neq 0$, $x + 2$ is not a factor of $P(x)$.

Repeat the division shown above using synthetic division. Note that the divisor $x + 2 = x - (-2)$.

$$\begin{array}{r|rrrrr}
 -2 & 1 & -6 & 9 & 4 & -12 \\
 & & -2 & 16 & -50 & 92 \\
 \hline
 & 1 & -8 & 25 & -46 & 80
 \end{array}$$

Again, note that $Q(x) = x^3 - 8x^2 + 25x - 46$ and $R(x) = 80$. Since $R(x) \neq 0$, $x - (-2)$, or $x + 2$, is not a factor of $P(x)$.

Now divide $P(x)$ by $x - 3$.

$$\begin{array}{r|rrrrr}
 3 & 1 & -6 & 9 & 4 & -12 \\
 & & 3 & -9 & 0 & 12 \\
 \hline
 & 1 & -3 & 0 & 4 & 0
 \end{array}$$

$Q(x) = x^3 - 3x^2 + 4$ and $R(x) = 0$. Since $R(x) = 0$, $x - 3$ is a factor of $P(x)$.

For $f(x) = 2x^5 - x^3 - 3x^2 - 4x + 15$, find $f(-2)$.

$$\begin{array}{r|rrrrrr}
 -2 & 2 & 0 & -1 & -3 & -4 & 15 \\
 & & -4 & 8 & -14 & 34 & -60 \\
 \hline
 & 2 & -4 & 7 & -17 & 30 & -45
 \end{array}$$

Thus, $f(-2) = -45$.

The Factor Theorem

For a polynomial $f(x)$, if $f(c) = 0$, then $x - c$ is a factor of $f(x)$.

Let $g(x) = x^4 + 8x^3 + 6x^2 - 40x + 25$. Factor $g(x)$ and solve $g(x) = 0$.

Use synthetic division to look for factors of the form $x - c$. Let's try $x + 5$.

$$\begin{array}{r|rrrrr} -5 & 1 & 8 & 6 & -40 & 25 \\ & & -5 & -15 & 45 & -25 \\ \hline & 1 & 3 & -9 & 5 & 0 \end{array}$$

Since $g(-5) = 0$, the number -5 is a zero of $g(x)$ and $x - (-5)$, or $x + 5$, is a factor of $g(x)$. This gives us

$$g(x) = (x + 5)(x^3 + 3x^2 - 9x + 5).$$

Let's try $x + 5$ again with the factor $x^3 + 3x^2 - 9x + 5$.

$$\begin{array}{r|rrrr} -5 & 1 & 3 & -9 & 5 \\ & & -5 & 10 & -5 \\ \hline & 1 & -2 & 1 & 0 \end{array}$$

Now we have

$$g(x) = (x + 5)^2(x^2 - 2x + 1).$$

The trinomial $x^2 - 2x + 1$ easily factors, so

$$g(x) = (x + 5)^2(x - 1)^2.$$

Solve $g(x) = 0$. The solutions of $(x + 5)^2(x - 1)^2 = 0$ are -5 and 1 . They are also the zeros of $g(x)$.

SECTION 4.4: THEOREMS ABOUT ZEROS OF POLYNOMIAL FUNCTIONS**The Fundamental Theorem of Algebra**

Every polynomial function of degree n , $n \geq 1$, with complex coefficients has at least one zero in the system of complex numbers.

Every polynomial function f of degree n , with $n \geq 1$, can be factored into n linear factors (not necessarily unique); that is,

$$f(x) = a_n(x - c_1)(x - c_2) \cdots (x - c_n).$$

Nonreal Zeros

$$a + bi \text{ and } a - bi, b \neq 0$$

If a complex number $a + bi$, $b \neq 0$, is a zero of a polynomial function $f(x)$ with *real* coefficients, then its conjugate, $a - bi$, is also a zero. (Nonreal zeros occur in conjugate pairs.)

Irrational Zeros

$$a + c\sqrt{b}, \text{ and } a - c\sqrt{b},$$

b not a perfect square

If $a + c\sqrt{b}$, where a , b , and c are rational and b is not a perfect square, is a zero of a polynomial function $f(x)$ with *rational* coefficients, then its conjugate, $a - c\sqrt{b}$, is also a zero. (Irrational zeros occur in conjugate pairs.)

Find a polynomial function of degree 5 with -4 and 2 as zeros of multiplicity 1, and -1 as a zero of multiplicity 3.

$$\begin{aligned} f(x) &= [x - (-4)][x - 2][x - (-1)]^3 \\ &= (x + 4)(x - 2)(x + 1)^3 \\ &= x^5 + 5x^4 + x^3 - 17x^2 - 22x - 8 \end{aligned}$$

Find a polynomial function with rational coefficients of lowest degree with $1 - i$ and $\sqrt{7}$ as two of its zeros.

If $1 - i$ is a zero, then $1 + i$ is also a zero. If $\sqrt{7}$ is a zero, then $-\sqrt{7}$ is also a zero.

$$\begin{aligned} f(x) &= [x - (1 - i)][x - (1 + i)][x - (-\sqrt{7})][x - \sqrt{7}] \\ &= [(x - 1) + i][(x - 1) - i](x + \sqrt{7})(x - \sqrt{7}) \\ &= [(x - 1)^2 - i^2](x^2 - 7) \\ &= (x^2 - 2x + 1 + 1)(x^2 - 7) \\ &= (x^2 - 2x + 2)(x^2 - 7) \\ &= x^4 - 2x^3 - 5x^2 + 14x - 14 \end{aligned}$$

The Rational Zeros Theorem

Consider the polynomial function

$$P(x) = a_n x^n + a_{n-1} x^{n-1} + a_{n-2} x^{n-2} + \dots + a_1 x + a_0,$$

where all the coefficients are integers and $n \geq 1$. Also, consider a rational number p/q , where p and q have no common factor other than -1 and 1 . If p/q is a zero of $P(x)$, then p is a factor of a_0 and q is a factor of a_n .

For $f(x) = 2x^4 - 9x^3 - 16x^2 - 9x - 18$, solve $f(x) = 0$ and factor $f(x)$ into linear factors.

There are at most 4 distinct zeros. Any rational zeros of f must be of the form p/q , where p is a factor of -18 and q is a factor of 2 .

$$\begin{array}{l} \text{Possibilities for } p: \\ \text{Possibilities for } q: \end{array} \quad \frac{\pm 1, \pm 2, \pm 3, \pm 6, \pm 9, \pm 18}{\pm 1, \pm 2}$$

$$\text{Possibilities for } p/q: \quad 1, -1, 2, -2, 3, -3, 6, -6, 9, -9, 18, -18, \frac{1}{2}, -\frac{1}{2}, \frac{3}{2}, -\frac{3}{2}, \frac{9}{2}, -\frac{9}{2}$$

Use synthetic division to check the possibilities. We leave it to the student to verify that $\pm 1, \pm 2$, and ± 3 are not zeros. Let's try 6 .

$$\begin{array}{r|rrrrr} 6 & 2 & -9 & -16 & -9 & -18 \\ & & 12 & 18 & 12 & 18 \\ \hline & 2 & 3 & 2 & 3 & 0 \end{array}$$

Since $f(6) = 0$, 6 is a zero and $x - 6$ is a factor of $f(x)$. Now express $f(x)$ as

$$f(x) = (x - 6)(2x^3 + 3x^2 + 2x + 3).$$

Consider the factor $2x^3 + 3x^2 + 2x + 3$ and check the other possibilities. Let's try $-\frac{3}{2}$.

$$\begin{array}{r|rrrr} -\frac{3}{2} & 2 & 3 & 2 & 3 \\ & & -3 & 0 & -3 \\ \hline & 2 & 0 & 2 & 0 \end{array}$$

Since $f(-\frac{3}{2}) = 0$, $-\frac{3}{2}$ is also a zero and $x + \frac{3}{2}$ is a factor of $f(x)$. We express $f(x)$ as

$$\begin{aligned} f(x) &= (x - 6)\left(x + \frac{3}{2}\right)(2x^2 + 2) \\ &= 2(x - 6)\left(x + \frac{3}{2}\right)(x^2 + 1). \end{aligned}$$

Now solve the equation $f(x) = 0$ to determine the zeros. We see that the only rational zeros are 6 and $-\frac{3}{2}$. The other zeros are $\pm i$.

The factorization into linear factors is

$$\begin{aligned} f(x) &= 2(x - 6)\left(x + \frac{3}{2}\right)(x - i)(x + i), \quad \text{or} \\ &= (x - 6)(2x + 3)(x - i)(x + i). \end{aligned}$$

Descartes' Rule of Signs

Let $P(x)$, written in descending or ascending order, be a polynomial function with real coefficients and a nonzero constant term. The number of positive real zeros of $P(x)$ is either:

1. The same as the number of variations of sign in $P(x)$, or
2. Less than the number of variations of sign in $P(x)$ by a positive even integer.

The number of negative real zeros of $P(x)$ is either:

3. The same as the number of variations of sign in $P(-x)$, or
4. Less than the number of variations of sign in $P(-x)$ by a positive even integer.

A zero of multiplicity m must be counted m times.

Determine the number of positive real zeros and the number of negative real zeros of

$$P(x) = 4x^5 - x^4 - 2x^3 + 8x - 10.$$

There are 3 variations of sign in $P(x)$. Thus the number of positive real zeros is 3 or 1.

$$P(-x) = -4x^5 - x^4 + 2x^3 - 8x - 10$$

There are 2 variations of sign in $P(-x)$. Thus the number of negative real zeros is 2 or 0.

SECTION 4.5: RATIONAL FUNCTIONS

Rational Function

$$f(x) = \frac{p(x)}{q(x)},$$

where $p(x)$ and $q(x)$ are polynomials and $q(x)$ is not the zero polynomial. The domain of $f(x)$ consists of all x for which $q(x) \neq 0$.

Vertical Asymptotes

For a rational function $f(x) = p(x)/q(x)$, where $p(x)$ and $q(x)$ are polynomials with *no common factors* other than constants, if a is a zero of the denominator, then the line $x = a$ is a vertical asymptote for the graph of the function.

Horizontal Asymptotes

When the numerator and the denominator have the same degree, the line $y = a/b$ is the horizontal asymptote, where a and b are the leading coefficients of the numerator and the denominator, respectively.

When the degree of the numerator is less than the degree of the denominator, the x -axis, or $y = 0$, is the horizontal asymptote.

When the degree of the numerator is greater than the degree of the denominator, there is *no* horizontal asymptote.

Oblique Asymptotes

When the degree of the numerator is 1 greater than the degree of the denominator, there is an oblique asymptote.

To Graph a Rational Function

$f(x) = p(x)/q(x)$, where $p(x)$ and $q(x)$ have no common factor other than constants:

1. Find any real zeros of the denominator. Determine the domain of the function and sketch any vertical asymptotes.
2. Find the horizontal asymptote or the oblique asymptote, if there is one, and sketch it.
3. Find any zeros of the function. The zeros are found by determining the zeros of the numerator. These are the first coordinates of the x -intercepts of the graph.

Determine the domain of each function.

FUNCTION	DOMAIN
$f(x) = \frac{1}{x^5}$	$(-\infty, 0) \cup (0, \infty)$
$f(x) = \frac{x+6}{x^2+2x-8}$ $= \frac{x+6}{(x-2)(x+4)}$	$(-\infty, -4) \cup (-4, 2) \cup (2, \infty)$

Determine the vertical, horizontal, and oblique asymptotes of the graph of the function.

FUNCTION	ASYMPTOTES
$f(x) = \frac{x^2-2}{x-1}$	Vertical: $x = 1$ Horizontal: None Oblique: $y = x + 1$
$f(x) = \frac{3x-4}{x^2+6x-7}$	Vertical: $x = -7; x = 1$ Horizontal: $y = 0$ Oblique: None
$f(x) = \frac{2x^2+9x-5}{3x^2+13x+12}$	Vertical: $x = -\frac{4}{3}; x = -3$ Horizontal: $y = \frac{2}{3}$ Oblique: None

Graph: $g(x) = \frac{x^2-4}{x^2+4x-5}$.

Domain: The zeros of the denominator are -5 and 1 . The domain is $(-\infty, -5) \cup (-5, 1) \cup (1, \infty)$.

Vertical asymptotes: Since neither zero of the denominator is a zero of the numerator, the graph has vertical asymptotes at $x = -5$ and $x = 1$.

Horizontal asymptote: The degree of the numerator is the same as the degree of the denominator, so the horizontal asymptote is determined by the ratio of the leading coefficients: $1/1$, or 1 . The horizontal asymptote is $y = 1$.

(Continued)

4. Find $f(0)$. This gives the y -intercept, $(0, f(0))$, of the function.
5. Find other function values to determine the general shape. Then draw the graph.

Crossing an Asymptote

The graph of a rational function never crosses a vertical asymptote.

The graph of a rational function might cross a horizontal asymptote but does not necessarily do so.

Oblique asymptote: None

Zeros of g : Solving $g(x) = 0$ gives us -2 and 2 , so the zeros are -2 and 2 .

x -intercepts: $(-2, 0)$ and $(2, 0)$

y -intercept: $(0, \frac{4}{5})$

Other values:

x	y
-8	2.22
-6	4.57
-4	-2.4
-3	-0.63
-1	0.38
0.5	1.36
1.5	-0.54
3	0.31
4	0.44

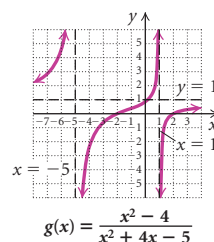

Graph: $f(x) = \frac{x + 3}{x^2 - x - 12}$.

Domain: The zeros of the denominator are -3 and 4 . The domain is $(-\infty, -3) \cup (-3, 4) \cup (4, \infty)$.

Vertical asymptote: Since 4 is the only zero of the denominator that is not a zero of the numerator, the only vertical asymptote is $x = 4$.

Horizontal asymptote: Because the degree of the numerator is less than the degree of the denominator, the x -axis, $y = 0$, is the horizontal asymptote.

Oblique asymptote: None

Zeros of f : The equation $f(x) = 0$ has no solutions, so there are no zeros of f .

x -intercepts: None

y -intercept: $(0, -\frac{1}{4})$

“Hole” in the graph:

$$f(x) = \frac{x + 3}{(x + 3)(x - 4)} = \frac{1}{x - 4}, \text{ where } x \neq -3 \text{ and } x \neq 4.$$

To determine the coordinates of the “hole,” substitute -3 for x in $f(x) = 1/(x - 4)$:

$$f(-3) = \frac{1}{-3 - 4} = -\frac{1}{7}.$$

The “hole” is located at $(-3, -\frac{1}{7})$.

Other values:

x	y
-4	-0.13
-2	-0.17
1	-0.33
3	-1
5	1
7	0.33

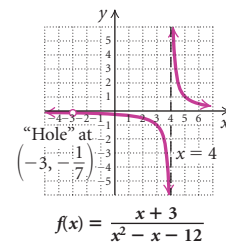

SECTION 4.6: POLYNOMIAL INEQUALITIES AND RATIONAL INEQUALITIES

To Solve a Polynomial Inequality

1. Find an equivalent inequality with 0 on one side.
2. Change the inequality symbol to an equals sign and solve the related equation.
3. Use the solutions to divide the x -axis into intervals. Then select a test value from each interval and determine the polynomial's sign on the interval.
4. Determine the intervals for which the inequality is satisfied and write interval notation or set-builder notation for the solution set. Include the endpoints of the intervals in the solution set if the inequality symbol is \leq or \geq .

Solve: $x^3 - 3x^2 \leq 6x - 8$.

Equivalent inequality: $x^3 - 3x^2 - 6x + 8 \leq 0$.

First solve the related equation:

$$x^3 - 3x^2 - 6x + 8 = 0.$$

The solutions are -2 , 1 , and 4 . The numbers divide the x -axis into 4 intervals. Next, let $f(x) = x^3 - 3x^2 - 6x + 8$ and, using test values for $f(x)$, determine the sign of $f(x)$ in each interval.

INTERVAL	TEST VALUE	SIGN OF $f(x)$
$(-\infty, -2)$	$f(-3) = -28$	-
$(-2, 1)$	$f(0) = 8$	+
$(1, 4)$	$f(2) = -8$	-
$(4, \infty)$	$f(6) = 80$	+



Test values are negative in the intervals $(-\infty, -2)$ and $(1, 4)$. Since the inequality sign is \leq , include the endpoints of the intervals in the solution set. The solution set is

$$(-\infty, -2] \cup [1, 4].$$

To Solve a Rational Inequality

1. Find an equivalent inequality with 0 on one side.
2. Change the inequality symbol to an equals sign and solve the related equation.
3. Find values of the variable for which the related rational function is not defined.
4. The numbers found in steps (2) and (3) are called *critical values*. Use the critical values to divide the x -axis into intervals. Then determine the function's sign in each interval using an x -value from the interval or the graph of the equation.
5. Select the intervals for which the inequality is satisfied and write interval notation or set-builder notation for the solution set. If the inequality symbol is \leq or \geq , then the solutions to step (2) should be included in the solution set. The x -values found in step (3) are never included in the solution set.

Solve: $\frac{x-1}{x+5} > \frac{x+3}{x-2}$.

Equivalent inequality: $\frac{x-1}{x+5} - \frac{x+3}{x-2} > 0$

Related function: $f(x) = \frac{x-1}{x+5} - \frac{x+3}{x-2}$

The function is not defined for $x = -5$ and $x = 2$. Solving $f(x) = 0$, we get $x = -\frac{13}{11}$. The critical values are -5 , $-\frac{13}{11}$, and 2 . These divide the x -axis into four intervals.

INTERVAL	TEST VALUE	SIGN OF $f(x)$
$(-\infty, -5)$	$f(-6) = 6.63$	+
$(-5, -\frac{13}{11})$	$f(-2) = -0.75$	-
$(-\frac{13}{11}, 2)$	$f(0) = 1.3$	+
$(2, \infty)$	$f(3) = -5.75$	-

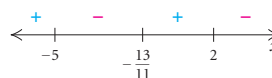

Test values are positive in the intervals $(-\infty, -5)$ and $(-\frac{13}{11}, 2)$. Since $f(-\frac{13}{11}) = 0$ and -5 and 2 are not in the domain of f , -5 , $-\frac{13}{11}$, and 2 cannot be part of the solution set. The solution set is

$$(-\infty, -5) \cup (-\frac{13}{11}, 2).$$

REVIEW EXERCISES

Determine whether the statement is true or false.

1. If $f(x) = (x+a)(x+b)(x-c)$, then $f(-b) = 0$. [4.3]
2. The graph of a rational function never crosses a vertical asymptote. [4.5]
3. For the function $g(x) = x^4 - 8x^2 - 9$, the only possible rational zeros are $1, -1, 3$, and -3 . [4.4]
4. The graph of $P(x) = x^6 - x^8$ has at most 6 x -intercepts. [4.2]
5. The domain of the function

$$f(x) = \frac{x-4}{(x+2)(x-3)}$$
 is $(-\infty, -2) \cup (3, \infty)$. [4.5]

Determine the leading term, the leading coefficient, and the degree of the polynomial. Then classify the polynomial function as constant, linear, quadratic, cubic, or quartic. [4.1]

6. $f(x) = 7x^2 - 5 + 0.45x^4 - 3x^3$

7. $h(x) = -25$

8. $g(x) = 6 - 0.5x$

9. $f(x) = \frac{1}{3}x^3 - 2x + 3$

Use the leading-term test to describe the end behavior of the graph of the function. [4.1]

10. $f(x) = -\frac{1}{2}x^4 + 3x^2 + x - 6$

11. $f(x) = x^5 + 2x^3 - x^2 + 5x + 4$

Find the zeros of the polynomial function and state the multiplicity of each. [4.1]

12. $g(x) = \left(x - \frac{2}{3}\right)(x + 2)^3(x - 5)^2$

13. $f(x) = x^4 - 26x^2 + 25$

14. $h(x) = x^3 + 4x^2 - 9x - 36$

15. **Interest Compounded Annually.** When P dollars is invested at interest rate i , compounded annually, for t years, the investment grows to A dollars, where

$$A = P(1 + i)^t.$$

- a) Find the interest rate i if \$6250 grows to \$6760 in 2 years. [4.1]
 b) Find the interest rate i if \$1,000,000 grows to \$1,215,506.25 in 4 years. [4.1]

Sketch the graph of the polynomial function.

16. $f(x) = -x^4 + 2x^3$ [4.2]

17. $g(x) = (x - 1)^3(x + 2)^2$ [4.2]

18. $h(x) = x^3 + 3x^2 - x - 3$ [4.2]

19. $f(x) = x^4 - 5x^3 + 6x^2 + 4x - 8$ [4.2], [4.3], [4.4]

20. $g(x) = 2x^3 + 7x^2 - 14x + 5$ [4.2], [4.4]

Using the intermediate value theorem, determine, if possible, whether the function f has a zero between a and b . [4.2]

21. $f(x) = 4x^2 - 5x - 3$; $a = 1, b = 2$

22. $f(x) = x^3 - 4x^2 + \frac{1}{2}x + 2$; $a = -1, b = 1$

In each of the following, a polynomial $P(x)$ and a divisor $d(x)$ are given. Use long division to find the quotient $Q(x)$ and the remainder $R(x)$ when $P(x)$ is divided by $d(x)$. Express $P(x)$ in the form $d(x) \cdot Q(x) + R(x)$. [4.3]

23. $P(x) = 6x^3 - 2x^2 + 4x - 1, d(x) = x - 3$

24. $P(x) = x^4 - 2x^3 + x + 5, d(x) = x + 1$

Use synthetic division to find the quotient and the remainder. [4.3]

25. $(x^3 + 2x^2 - 13x + 10) \div (x - 5)$

26. $(x^4 + 3x^3 + 3x^2 + 3x + 2) \div (x + 2)$

27. $(x^5 - 2x) \div (x + 1)$

Use synthetic division to find the indicated function value. [4.3]

28. $f(x) = x^3 + 2x^2 - 13x + 10$; $f(-2)$

29. $f(x) = x^4 - 16$; $f(-2)$

30. $f(x) = x^5 - 4x^4 + x^3 - x^2 + 2x - 100$;
 $f(-10)$

Using synthetic division, determine whether the given numbers are zeros of the polynomial function. [4.3]

31. $-i, -5$; $f(x) = x^3 - 5x^2 + x - 5$

32. $-1, -2$; $f(x) = x^4 - 4x^3 - 3x^2 + 14x - 8$

33. $\frac{1}{3}, 1$; $f(x) = x^3 - \frac{4}{3}x^2 - \frac{5}{3}x + \frac{2}{3}$

34. $2, -\sqrt{3}$; $f(x) = x^4 - 5x^2 + 6$

Factor the polynomial $f(x)$. Then solve the equation $f(x) = 0$. [4.3], [4.4]

35. $f(x) = x^3 + 2x^2 - 7x + 4$

36. $f(x) = x^3 + 4x^2 - 3x - 18$

37. $f(x) = x^4 - 4x^3 - 21x^2 + 100x - 100$

38. $f(x) = x^4 - 3x^2 + 2$

Find a polynomial function of degree 3 with the given numbers as zeros. [4.4]

39. $-4, -1, 2$

40. $-3, 1 - i, 1 + i$

41. $\frac{1}{2}, 1 - \sqrt{2}, 1 + \sqrt{2}$

42. Find a polynomial function of degree 4 with -5 as a zero of multiplicity 3 and $\frac{1}{2}$ as a zero of multiplicity 1. [4.4]

43. Find a polynomial function of degree 5 with -3 as a zero of multiplicity 2, 2 as a zero of multiplicity 1, and 0 as a zero of multiplicity 2. [4.4]

Suppose that a polynomial function of degree 5 with rational coefficients has the given zeros. Find the other zero(s). [4.4]

44. $-\frac{2}{3}, \sqrt{5}, i$
 45. $0, 1 + \sqrt{3}, -\sqrt{3}$
 46. $-\sqrt{2}, \frac{1}{2}, 1, 2$

Find a polynomial function of lowest degree with rational coefficients and the following as some of its zeros. [4.4]

47. $\sqrt{11}$
 48. $-i, 6$
 49. $-1, 4, 1 + i$
 50. $\sqrt{5}, -2i$
 51. $\frac{1}{3}, 0, -3$

List all possible rational zeros. [4.4]

52. $h(x) = 4x^5 - 2x^3 + 6x - 12$
 53. $g(x) = 3x^4 - x^3 + 5x^2 - x + 1$
 54. $f(x) = x^3 - 2x^2 + x - 24$

For each polynomial function:

- a) Find the rational zeros and then the other zeros; that is, solve $f(x) = 0$. [4.4]
 b) Factor $f(x)$ into linear factors. [4.4]

55. $f(x) = 3x^5 + 2x^4 - 25x^3 - 28x^2 + 12x$
 56. $f(x) = x^3 - 2x^2 - 3x + 6$
 57. $f(x) = x^4 - 6x^3 + 9x^2 + 6x - 10$
 58. $f(x) = x^3 + 3x^2 - 11x - 5$
 59. $f(x) = 3x^3 - 8x^2 + 7x - 2$
 60. $f(x) = x^5 - 8x^4 + 20x^3 - 8x^2 - 32x + 32$
 61. $f(x) = x^6 + x^5 - 28x^4 - 16x^3 + 192x^2$
 62. $f(x) = 2x^5 - 13x^4 + 32x^3 - 38x^2 + 22x - 5$

What does Descartes' rule of signs tell you about the number of positive real zeros and the number of negative real zeros of each of the following polynomial functions? [4.4]

63. $f(x) = 2x^6 - 7x^3 + x^2 - x$

64. $h(x) = -x^8 + 6x^5 - x^3 + 2x - 2$

65. $g(x) = 5x^5 - 4x^2 + x - 1$

Graph the function. Be sure to label all the asymptotes. List the domain and the x - and y -intercepts. [4.5]

66. $f(x) = \frac{x^2 - 5}{x + 2}$ 67. $f(x) = \frac{5}{(x - 2)^2}$

68. $f(x) = \frac{x^2 + x - 6}{x^2 - x - 20}$ 69. $f(x) = \frac{x - 2}{x^2 - 2x - 15}$

In Exercises 70 and 71, find a rational function that satisfies the given conditions. Answers may vary, but try to give the simplest answer possible. [4.5]

70. Vertical asymptotes $x = -2, x = 3$
 71. Vertical asymptotes $x = -2, x = 3$; horizontal asymptote $y = 4$; x -intercept $(-3, 0)$

72. **Medical Dosage.** The function

$$N(t) = \frac{0.7t + 2000}{8t + 9}, \quad t \geq 5$$

gives the body concentration $N(t)$, in parts per million, of a certain dosage of medication after time t , in hours.

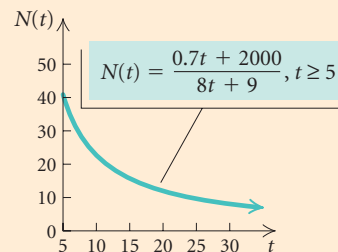

- a) Find the horizontal asymptote of the graph and complete the following:

$$N(t) \rightarrow \square \text{ as } t \rightarrow \infty. \quad [4.5]$$

- b) Explain the meaning of the answer to part (a) in terms of the application. [4.5]

Solve. [4.6]

73. $x^2 - 9 < 0$
 74. $2x^2 > 3x + 2$
 75. $(1 - x)(x + 4)(x - 2) \leq 0$
 76. $\frac{x - 2}{x + 3} < 4$

77. **Height of a Rocket.** The function

$$S(t) = -16t^2 + 80t + 224$$

gives the height S , in feet, of a model rocket launched with a velocity of 80 ft/sec from a hill that is 224 ft high, where t is the time, in seconds.

- a) Determine when the rocket reaches the ground. [4.1]
 b) On what interval is the height greater than 320 ft? [4.1], [4.6]

78. **Population Growth.** The population P , in thousands, of Novi is given by

$$P(t) = \frac{8000t}{4t^2 + 10}$$

where t is the time, in months. Find the interval on which the population was 400,000 or greater. [4.6]

79. Determine the domain of the function

$$g(x) = \frac{x^2 + 2x - 3}{x^2 - 5x + 6}. \quad [4.5]$$

- A. $(-\infty, 2) \cup (2, 3) \cup (3, \infty)$
 B. $(-\infty, -3) \cup (-3, 1) \cup (1, \infty)$
 C. $(-\infty, 2) \cup (3, \infty)$
 D. $(-\infty, -3) \cup (1, \infty)$
80. Determine the vertical asymptotes of the function

$$f(x) = \frac{x - 4}{(x + 1)(x - 2)(x + 4)}. \quad [4.5]$$

- A. $x = 1, x = -2$, and $x = 4$
 B. $x = -1, x = 2, x = -4$, and $x = 4$
 C. $x = -1, x = 2$, and $x = -4$
 D. $x = 4$
81. The graph of $f(x) = -\frac{1}{2}x^4 + x^3 + 1$ is which of the following? [4.2]

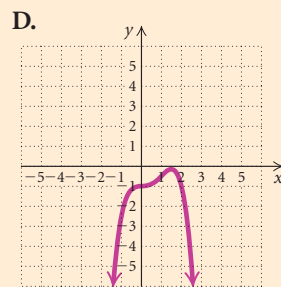
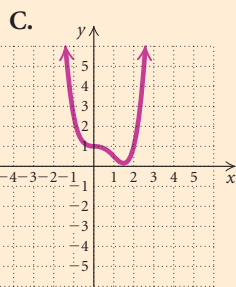
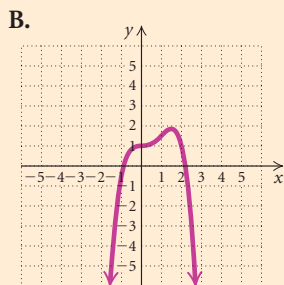
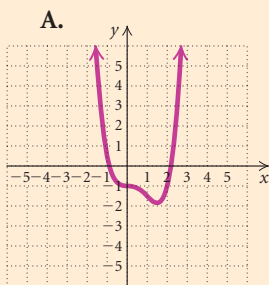

Synthesis

Solve.

82. $x^2 \geq 5 - 2x$ [4.6]
 83. $\left| 1 - \frac{1}{x^2} \right| < 3$ [4.6]
 84. $x^4 - 2x^3 + 3x^2 - 2x + 2 = 0$ [4.4], [4.5]
 85. $(x - 2)^{-3} < 0$ [4.6]
 86. Express $x^3 - 1$ as a product of linear factors. [4.4]
 87. Find k such that $x + 3$ is a factor of $x^3 + kx^2 + kx - 15$. [4.3]
 88. When $x^2 - 4x + 3k$ is divided by $x + 5$, the remainder is 33. Find the value of k . [4.3]

Find the domain of the function. [4.5]

89. $f(x) = \sqrt{x^2 + 3x - 10}$
 90. $f(x) = \sqrt{x^2 - 3.1x + 2.2} + 1.75$
 91. $f(x) = \frac{1}{\sqrt{5 - |7x + 2|}}$

Collaborative Discussion and Writing

92. Explain the difference between a polynomial function and a rational function. [4.1], [4.5]
 93. Is it possible for a third-degree polynomial with rational coefficients to have no real zeros? Why or why not? [4.4]
 94. Explain and contrast the three types of asymptotes considered for rational functions. [4.5]
 95. If $P(x)$ is an even function, and by Descartes' rule of signs, $P(x)$ has one positive real zero, how many negative real zeros does $P(x)$ have? Explain. [4.4]

96. Explain why the graph of a rational function cannot have both a horizontal asymptote and an oblique asymptote. [4.5]
97. Under what circumstances would a quadratic inequality have a solution set that is a closed interval? [4.6]

Chapter 4 Test

Determine the leading term, the leading coefficient, and the degree of the polynomial. Then classify the polynomial as constant, linear, quadratic, cubic, or quartic.

- $f(x) = 2x^3 + 6x^2 - x^4 + 11$
- $h(x) = -4.7x + 29$
- Find the zeros of the polynomial function and state the multiplicity of each:
 $f(x) = x(3x - 5)(x - 3)^2(x + 1)^3$.
- Foreign-Born Population.** In 1970, only 4.7% of the U.S. population was foreign-born, while in 2007, 12.6% of the population was foreign-born (Sources: Annual Social and Economic Supplements, Current Population Surveys, U.S. Census Bureau, U.S. Department of Commerce). The quartic function
 $f(x) = -0.0000007623221x^4 + 0.00021189064x^3$
 $- 0.016314058x^2 + 0.2440779643x$
 $+ 13.59260684$,

where x is the number of years since 1900, can be used to estimate the percent of the U.S. population for years 1900 to 2007 that was foreign-born. Using this function, estimate the percent of the population that was foreign-born in 1930, in 1990, and in 2000.

Sketch the graph of the polynomial function.

- $f(x) = x^3 - 5x^2 + 2x + 8$
- $f(x) = -2x^4 + x^3 + 11x^2 - 4x - 12$

Using the intermediate value theorem, determine, if possible, whether the function has a zero between a and b .

- $f(x) = -5x^2 + 3$; $a = 0, b = 2$
- $g(x) = 2x^3 + 6x^2 - 3$; $a = -2, b = -1$

- Use long division to find the quotient $Q(x)$ and the remainder $R(x)$ when $P(x)$ is divided by $d(x)$. Express $P(x)$ in the form $d(x) \cdot Q(x) + R(x)$. Show your work.

$$P(x) = x^4 + 3x^3 + 2x - 5,$$

$$d(x) = x - 1$$

- Use synthetic division to find the quotient and the remainder. Show your work.
 $(3x^3 - 12x + 7) \div (x - 5)$
- Use synthetic division to find $P(-3)$ for $P(x) = 2x^3 - 6x^2 + x - 4$. Show your work.
- Use synthetic division to determine whether -2 is a zero of $f(x) = x^3 + 4x^2 + x - 6$. Answer yes or no. Show your work.
- Find a polynomial of degree 4 with -3 as a zero of multiplicity 2 and 0 and 6 as zeros of multiplicity 1.
- Suppose that a polynomial function of degree 5 with rational coefficients has 1, $\sqrt{3}$, and $2 - i$ as zeros. Find the other zeros.

Find a polynomial function of lowest degree with rational coefficients and the following as some of its zeros.

- $-10, 3i$
- $0, -\sqrt{3}, 1 - i$

List all possible rational zeros.

- $f(x) = 2x^3 + x^2 - 2x + 12$
- $h(x) = 10x^4 - x^3 + 2x - 5$

For each polynomial function:

- Find the rational zeros and then the other zeros; that is, solve $f(x) = 0$.
 - Factor $f(x)$ into linear factors.
- $f(x) = x^3 + x^2 - 5x - 5$

20. $f(x) = 2x^4 - 11x^3 + 16x^2 - x - 6$
21. $f(x) = x^3 + 4x^2 + 4x + 16$
22. $f(x) = 3x^4 - 11x^3 + 15x^2 - 9x + 2$
23. What does Descartes' rule of signs tell you about the number of positive real zeros and the number of negative real zeros of the following function?
- $$g(x) = -x^8 + 2x^6 - 4x^3 - 1$$

Graph the function. Be sure to label all the asymptotes. List the domain and the x - and y -intercepts.

24. $f(x) = \frac{2}{(x-3)^2}$ 25. $f(x) = \frac{x+3}{x^2-3x-4}$

26. Find a rational function that has vertical asymptotes $x = -1$ and $x = 2$ and x -intercept $(-4, 0)$.

Solve.

27. $2x^2 > 5x + 3$
28. $\frac{x+1}{x-4} \leq 3$
29. The function $S(t) = -16t^2 + 64t + 192$ gives the height S , in feet, of a model rocket launched with a velocity of 64 ft/sec from a hill that is 192 ft high.
- Determine how long it will take the rocket to reach the ground.
 - Find the interval on which the height of the rocket is greater than 240 ft.

30. The graph of $f(x) = x^3 - x^2 - 2$ is which of the following?

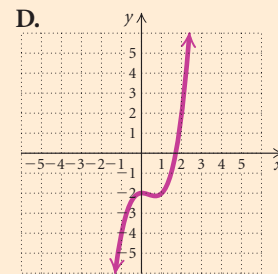
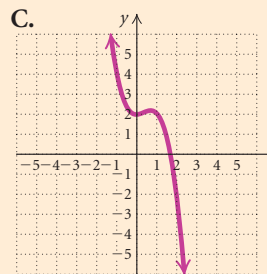
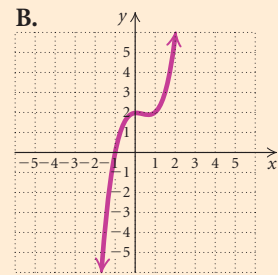
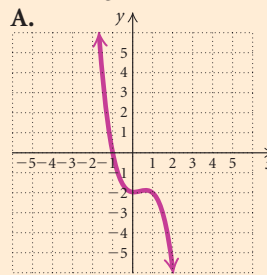

Synthesis

31. Find the domain of $f(x) = \sqrt{x^2 + x - 12}$.

Exponential Functions and Logarithmic Functions

CHAPTER

5



Application

The business of taxi medallions, required licenses fastened to the hood of all New York City cabs, has proven itself to be a valuable investment. The average price for the corporate-license taxi medallion in New York has risen from about \$200,000 in 2001 to \$753,000 in 2009 (Sources: New York City Taxi & Limousine Commission; Andrew Murstein, president of Medallion Financial). The exponential function

$$M(x) = (200,000)(1.1802)^x,$$

where x is the number of years since 2001, models the data for the average price of a medallion in recent years. Estimate the price of a taxi medallion in 2003 and in 2007. Then use the function to project the average price in 2013. Round to the nearest dollar.

This problem appears as Exercise 67 in Section 5.2.

- 5.1 Inverse Functions
- 5.2 Exponential Functions and Graphs
- 5.3 Logarithmic Functions and Graphs
- Visualizing the Graph
- Mid-Chapter Mixed Review
- 5.4 Properties of Logarithmic Functions
- 5.5 Solving Exponential Equations and Logarithmic Equations
- 5.6 Applications and Models: Growth and Decay; Compound Interest

Study Guide

Review Exercises

Chapter Test

Inverse Functions

5.1

- ▶ Determine whether a function is one-to-one, and if it is, find a formula for its inverse.
- ▶ Simplify expressions of the type $(f \circ f^{-1})(x)$ and $(f^{-1} \circ f)(x)$.

▶ Inverses

When we go from an output of a function back to its input or inputs, we get an inverse relation. When that relation is a function, we have an inverse function.

Consider the relation h given as follows:

$$h = \{(-8, 5), (4, -2), (-7, 1), (3.8, 6.2)\}.$$

Suppose we *interchange* the first and second coordinates. The relation we obtain is called the **inverse** of the relation h and is given as follows:

$$\text{Inverse of } h = \{(5, -8), (-2, 4), (1, -7), (6.2, 3.8)\}.$$

RELATIONS

REVIEW SECTION 1.2

Inverse Relation

Interchanging the first and second coordinates of each ordered pair in a relation produces the **inverse relation**.

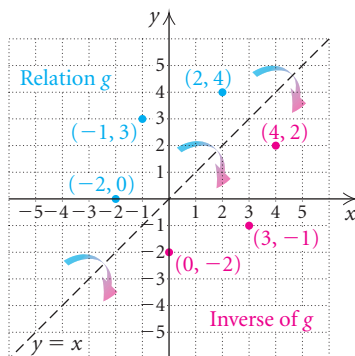

EXAMPLE 1 Consider the relation g given by

$$g = \{(2, 4), (-1, 3), (-2, 0)\}.$$

Graph the relation in blue. Find the inverse and graph it in red.

Solution The relation g is shown in blue in the figure at left. The inverse of the relation is

$$\{(4, 2), (3, -1), (0, -2)\}$$

and is shown in red. The pairs in the inverse are reflections of the pairs in g across the line $y = x$.

➔ Now Try Exercise 1.

Inverse Relation

If a relation is defined by an equation, interchanging the variables produces an equation of the **inverse relation**.

EXAMPLE 2 Find an equation for the inverse of the relation

$$y = x^2 - 5x.$$

Solution We interchange x and y and obtain an equation of the inverse:

$$x = y^2 - 5y.$$

➔ **Now Try Exercise 9.**

If a relation is given by an equation, then the solutions of the inverse can be found from those of the original equation by interchanging the first and second coordinates of each ordered pair. Thus the graphs of a relation and its inverse are always reflections of each other across the line $y = x$. This is illustrated with the equations of Example 2 in the tables and graph below. We will explore inverses and their graphs later in this section.

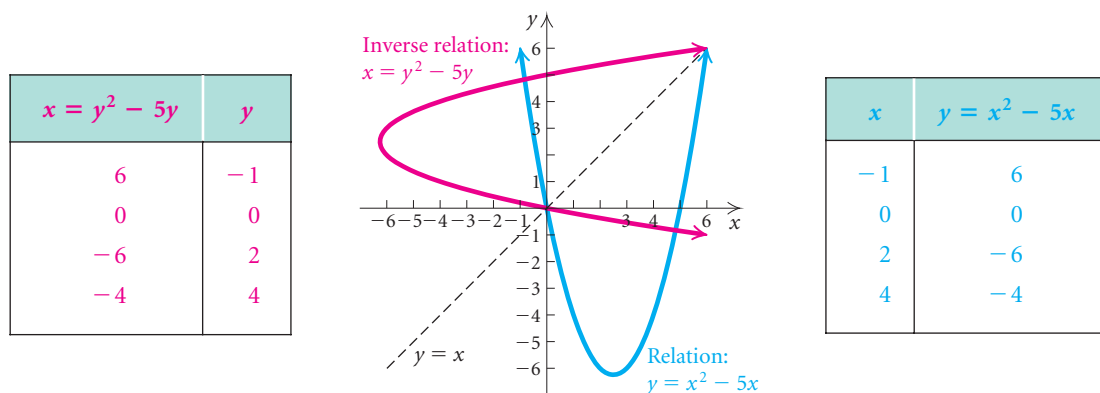

► Inverses and One-to-One Functions

Let's consider the following two functions.

Year (domain)	First-Class Postage Cost, in cents (range)
1996	32
1998	32
2000	33
2002	37
2004	37
2006	39
2007	41
2008	42
2009	44

Source: U.S. Postal Service

Number (domain)	Cube (range)
-3	-27
-2	-8
-1	-1
0	0
1	1
2	8
3	27

Suppose we reverse the arrows. Are these inverse relations functions?

Year (range)	First-Class Postage Cost, in cents (domain)
1996	32
1998	
2000	33
2002	37
2004	
2006	39
2007	41
2008	42
2009	44

Number (range)	Cube (domain)
-3	-27
-2	-8
-1	-1
0	0
1	1
2	8
3	27

Source: U.S. Postal Service

We see that the inverse of the postage function is not a function. Like all functions, each input in the postage function has exactly one output. However, the output for both 1996 and 1998 is 32. Thus in the inverse of the postage function, the input 32 has *two* outputs, 1996 and 1998. When two or more inputs of a function have the same output, the inverse relation cannot be a function. In the cubing function, each output corresponds to exactly one input, so its inverse is also a function. The cubing function is an example of a **one-to-one function**.

One-to-One Functions

A function f is **one-to-one** if different inputs have different outputs—that is,

$$\text{if } a \neq b, \text{ then } f(a) \neq f(b).$$

Or a function f is **one-to-one** if when the outputs are the same, the inputs are the same—that is,

$$\text{if } f(a) = f(b), \text{ then } a = b.$$

If the inverse of a function f is also a function, it is named f^{-1} (read “ f -inverse”).

The -1 in f^{-1} is *not* an exponent!

Do *not* misinterpret the -1 in f^{-1} as a negative exponent: f^{-1} does *not* mean the reciprocal of f and $f^{-1}(x)$ is *not* equal to $\frac{1}{f(x)}$.

One-to-One Functions and Inverses

- If a function f is one-to-one, then its inverse f^{-1} is a function.
- The domain of a one-to-one function f is the range of the inverse f^{-1} .
- The range of a one-to-one function f is the domain of the inverse f^{-1} .
- A function that is increasing over its entire domain or is decreasing over its entire domain is a one-to-one function.

$$\begin{array}{l} D_f \quad \times \quad D_{f^{-1}} \\ R_f \quad \times \quad R_{f^{-1}} \end{array}$$

EXAMPLE 3 Given the function f described by $f(x) = 2x - 3$, prove that f is one-to-one (that is, it has an inverse that is a function).

Solution To show that f is one-to-one, we show that if $f(a) = f(b)$, then $a = b$. Assume that $f(a) = f(b)$ for a and b in the domain of f . Since $f(a) = 2a - 3$ and $f(b) = 2b - 3$, we have

$$2a - 3 = 2b - 3$$

$$2a = 2b \quad \text{Adding 3}$$

$$a = b. \quad \text{Dividing by 2}$$

Thus, if $f(a) = f(b)$, then $a = b$. This shows that f is one-to-one.

➔ **Now Try Exercise 17.**

EXAMPLE 4 Given the function g described by $g(x) = x^2$, prove that g is not one-to-one.

Solution We can prove that g is not one-to-one by finding two numbers a and b for which $a \neq b$ and $g(a) = g(b)$. Two such numbers are -3 and 3 , because $-3 \neq 3$ and $g(-3) = g(3) = 9$. Thus g is not one-to-one.

➔ **Now Try Exercise 21.**

The following graphs show a function, in blue, and its inverse, in red. To determine whether the inverse is a function, we can apply the vertical-line test to its graph. By reflecting each such vertical line back across the line $y = x$, we obtain an equivalent **horizontal-line test** for the original function.

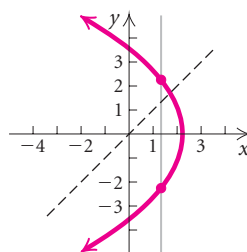
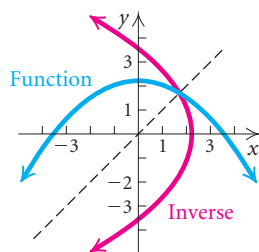

The vertical-line test shows that the inverse is not a function.

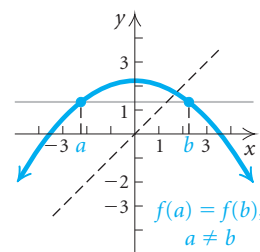

The horizontal-line test shows that the function is not one-to-one.

Horizontal-Line Test

If it is possible for a horizontal line to intersect the graph of a function more than once, then the function is *not* one-to-one and its inverse is *not* a function.

EXAMPLE 5 From the graph shown, determine whether each function is one-to-one and thus has an inverse that is a function.

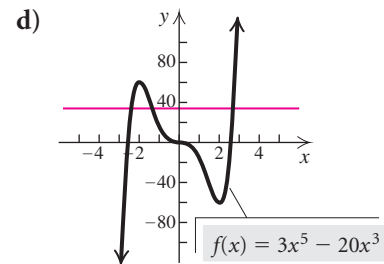
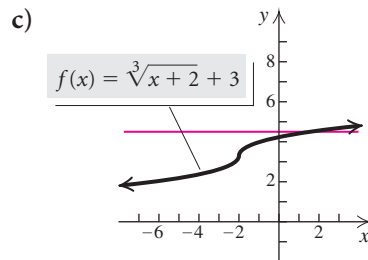
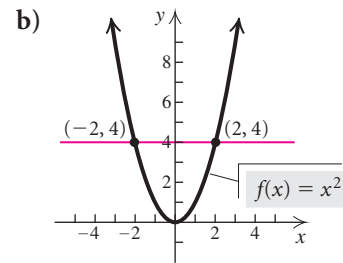
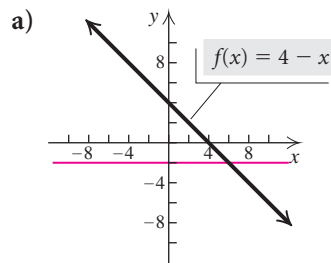

Solution For each function, we apply the horizontal-line test.

RESULT	REASON
a) One-to-one; inverse is a function	No horizontal line intersects the graph more than once.
b) Not one-to-one; inverse is not a function	There are many horizontal lines that intersect the graph more than once. Note that where the line $y = 4$ intersects the graph, the first coordinates are -2 and 2 . Although these are different inputs, they have the same output, 4 .
c) One-to-one; inverse is a function	No horizontal line intersects the graph more than once.
d) Not one-to-one; inverse is not a function	There are many horizontal lines that intersect the graph more than once.

Now Try Exercises 25 and 27.

► Finding Formulas for Inverses

Suppose that a function is described by a formula. If it has an inverse that is a function, we proceed as follows to find a formula for f^{-1} .

Obtaining a Formula for an Inverse

If a function f is one-to-one, a formula for its inverse can generally be found as follows:

1. Replace $f(x)$ with y .
2. Interchange x and y .
3. Solve for y .
4. Replace y with $f^{-1}(x)$.

EXAMPLE 6 Determine whether the function $f(x) = 2x - 3$ is one-to-one, and if it is, find a formula for $f^{-1}(x)$.

Solution The graph of f is shown at left. It passes the horizontal-line test. Thus it is one-to-one and its inverse is a function. We also proved that f is one-to-one in Example 3. We find a formula for $f^{-1}(x)$.

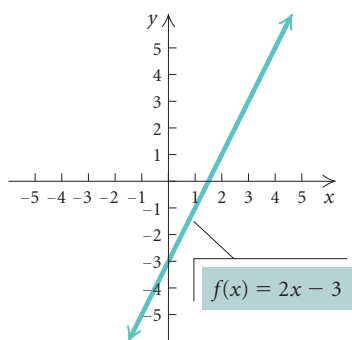

1. Replace $f(x)$ with y : $y = 2x - 3$
2. Interchange x and y : $x = 2y - 3$
3. Solve for y : $x + 3 = 2y$
 $\frac{x + 3}{2} = y$
4. Replace y with $f^{-1}(x)$: $f^{-1}(x) = \frac{x + 3}{2}$.

➔ Now Try Exercise 47.

Consider

$$f(x) = 2x - 3 \quad \text{and} \quad f^{-1}(x) = \frac{x + 3}{2}$$

from Example 6. For the input 5, we have

$$f(5) = 2 \cdot 5 - 3 = 10 - 3 = 7.$$

The output is 7. Now we use 7 for the input in the inverse:

$$f^{-1}(7) = \frac{7 + 3}{2} = \frac{10}{2} = 5.$$

The function f takes the number 5 to 7. The inverse function f^{-1} takes the number 7 back to 5.

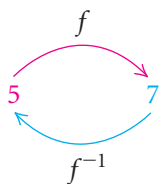

EXAMPLE 7 Graph

$$f(x) = 2x - 3 \quad \text{and} \quad f^{-1}(x) = \frac{x + 3}{2}$$

using the same set of axes. Then compare the two graphs.

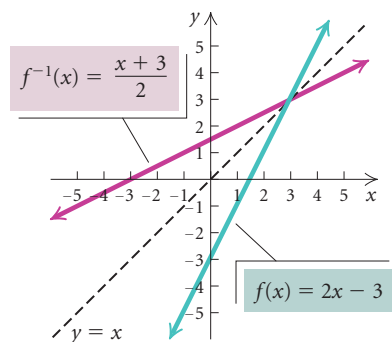

Solution The graphs of f and f^{-1} are shown at left. The solutions of the inverse function can be found from those of the original function by interchanging the first and second coordinates of each ordered pair.

x	$f(x) = 2x - 3$
-1	-5
0	-3 ← y -intercept
2	1
3	3

x	$f^{-1}(x) = \frac{x + 3}{2}$
-5	-1
-3	0 ← x -intercept
1	2
3	3

TECHNOLOGY CONNECTION

On some graphing calculators, we can graph the inverse of a function after graphing the function itself by accessing a drawing feature. Consult your user's manual or the online *Graphing Calculator Manual* that accompanies this text for the procedure.

When we interchange x and y in finding a formula for the inverse of $f(x) = 2x - 3$, we are in effect reflecting the graph of that function across the line $y = x$. For example, when the coordinates of the y -intercept, $(0, -3)$, of the graph of f are reversed, we get the x -intercept, $(-3, 0)$, of the graph of f^{-1} . If we were to graph $f(x) = 2x - 3$ in wet ink and fold along the line $y = x$, the graph of $f^{-1}(x) = (x + 3)/2$ would be formed by the ink transferred from f .

The graph of f^{-1} is a reflection of the graph of f across the line $y = x$.

EXAMPLE 8 Consider $g(x) = x^3 + 2$.

- Determine whether the function is one-to-one.
- If it is one-to-one, find a formula for its inverse.
- Graph the function and its inverse.

Solution

- The graph of $g(x) = x^3 + 2$ is shown at left. It passes the horizontal-line test and thus has an inverse that is a function. We also know that $g(x)$ is one-to-one because it is an increasing function over its entire domain.
- We follow the procedure for finding an inverse.

- Replace $g(x)$ with y : $y = x^3 + 2$
- Interchange x and y : $x = y^3 + 2$
- Solve for y : $\frac{x - 2}{3} = y^3$
 $\sqrt[3]{\frac{x - 2}{3}} = y$
- Replace y with $g^{-1}(x)$: $g^{-1}(x) = \sqrt[3]{\frac{x - 2}{3}}$

We can test a point as a partial check:

$$g(x) = x^3 + 2$$

$$g(3) = 3^3 + 2 = 27 + 2 = 29.$$

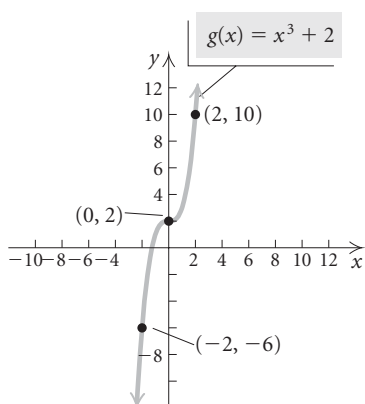

Will $g^{-1}(29) = 3$? We have

$$g^{-1}(x) = \sqrt[3]{x-2}$$

$$g^{-1}(29) = \sqrt[3]{29-2} = \sqrt[3]{27} = 3.$$

Since $g(3) = 29$ and $g^{-1}(29) = 3$, we can be reasonably certain that the formula for $g^{-1}(x)$ is correct.

- c) To find the graph, we reflect the graph of $g(x) = x^3 + 2$ across the line $y = x$. This can be done by plotting points.

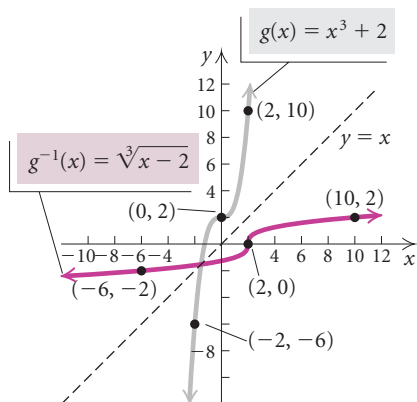

x	$g(x)$
-2	-6
-1	1
0	2
1	3
2	10

x	$g^{-1}(x)$
-6	-2
1	-1
2	0
3	1
10	2

➔ Now Try Exercise 69.

► Inverse Functions and Composition

Suppose that we were to use some input a for a one-to-one function f and find its output, $f(a)$. The function f^{-1} would then take that output back to a . Similarly, if we began with an input b for the function f^{-1} and found its output, $f^{-1}(b)$, the original function f would then take that output back to b . This is summarized as follows.

If a function f is one-to-one, then f^{-1} is the unique function such that each of the following holds:

$$(f^{-1} \circ f)(x) = f^{-1}(f(x)) = x, \quad \text{for each } x \text{ in the domain of } f, \text{ and}$$

$$(f \circ f^{-1})(x) = f(f^{-1}(x)) = x, \quad \text{for each } x \text{ in the domain of } f^{-1}.$$

EXAMPLE 9 Given that $f(x) = 5x + 8$, use composition of functions to show that

$$f^{-1}(x) = \frac{x-8}{5}.$$

Solution We find $(f^{-1} \circ f)(x)$ and $(f \circ f^{-1})(x)$ and check to see that each is x :

$$(f^{-1} \circ f)(x) = f^{-1}(f(x))$$

$$= f^{-1}(5x + 8) = \frac{(5x + 8) - 8}{5} = \frac{5x}{5} = x;$$

$$\begin{aligned}(f \circ f^{-1})(x) &= f(f^{-1}(x)) \\ &= f\left(\frac{x-8}{5}\right) = 5\left(\frac{x-8}{5}\right) + 8 = x - 8 + 8 = x.\end{aligned}$$

➔ Now Try Exercise 77.

► Restricting a Domain

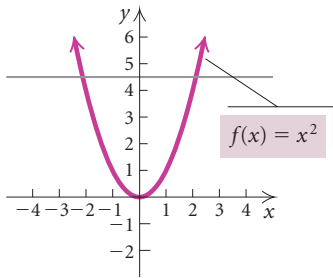

In the case in which the inverse of a function is not a function, the domain of the function can be restricted to allow the inverse to be a function. We saw in Examples 4 and 5(b) that $f(x) = x^2$ is not one-to-one. The graph is shown at left.

Suppose that we had tried to find a formula for the inverse as follows:

$$\begin{aligned}y &= x^2 && \text{Replacing } f(x) \text{ with } y \\ x &= y^2 && \text{Interchanging } x \text{ and } y \\ \pm\sqrt{x} &= y. && \text{Solving for } y\end{aligned}$$

This is not the equation of a function. An input of, say, 4 would yield two outputs, -2 and 2 . In such cases, it is convenient to consider “part” of the function by restricting the domain of $f(x)$. For example, if we restrict the domain of $f(x) = x^2$ to nonnegative numbers, then its inverse is a function, as shown with the graphs of $f(x) = x^2, x \geq 0$, and $f^{-1}(x) = \sqrt{x}$ below.

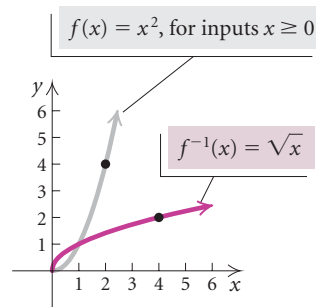

5.1 Exercise Set

Find the inverse of the relation.

- $\{(7, 8), (-2, 8), (3, -4), (8, -8)\}$
- $\{(0, 1), (5, 6), (-2, -4)\}$
- $\{(-1, -1), (-3, 4)\}$
- $\{(-1, 3), (2, 5), (-3, 5), (2, 0)\}$

Find an equation of the inverse relation.

- $y = 4x - 5$
- $2x^2 + 5y^2 = 4$
- $x^3y = -5$
- $y = 3x^2 - 5x + 9$

9. $x = y^2 - 2y$

10. $x = \frac{1}{2}y + 4$

Graph the equation by substituting and plotting points. Then reflect the graph across the line $y = x$ to obtain the graph of its inverse.

11. $x = y^2 - 3$

12. $y = x^2 + 1$

13. $y = 3x - 2$

14. $x = -y + 4$

15. $y = |x|$

16. $x + 2 = |y|$

Given the function f , prove that f is one-to-one using the definition of a one-to-one function on p. 390.

17. $f(x) = \frac{1}{3}x - 6$

18. $f(x) = 4 - 2x$

19. $f(x) = x^3 + \frac{1}{2}$

20. $f(x) = \sqrt[3]{x}$

Given the function g , prove that g is not one-to-one using the definition of a one-to-one function on p. 390.

21. $g(x) = 1 - x^2$

22. $g(x) = 3x^2 + 1$

23. $g(x) = x^4 - x^2$

24. $g(x) = \frac{1}{x^6}$

Using the horizontal-line test, determine whether the function is one-to-one.

25. $f(x) = 2.7^x$

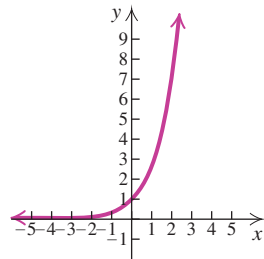

26. $f(x) = 2^{-x}$

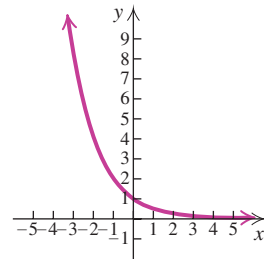

27. $f(x) = 4 - x^2$

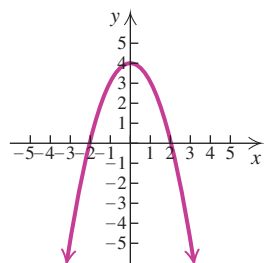

28. $f(x) = x^3 - 3x + 1$

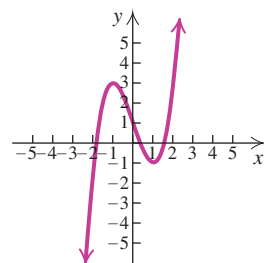

29. $f(x) = \frac{8}{x^2 - 4}$

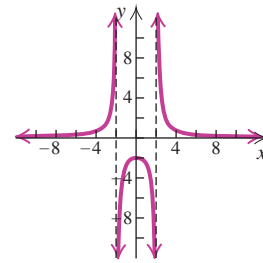

30. $f(x) = \sqrt{\frac{10}{4+x}}$

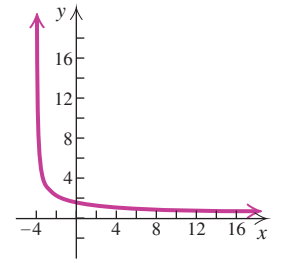

31. $f(x) = \sqrt[3]{x+2} - 2$

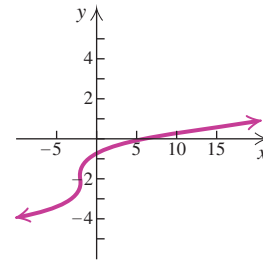

32. $f(x) = \frac{8}{x}$

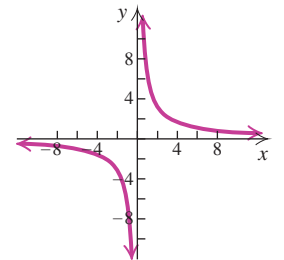

Graph the function and determine whether the function is one-to-one using the horizontal-line test.

33. $f(x) = 5x - 8$

34. $f(x) = 3 + 4x$

35. $f(x) = 1 - x^2$

36. $f(x) = |x| - 2$

37. $f(x) = |x + 2|$

38. $f(x) = -0.8$

39. $f(x) = -\frac{4}{x}$

40. $f(x) = \frac{2}{x+3}$

41. $f(x) = \frac{2}{3}$

42. $f(x) = \frac{1}{2}x^2 + 3$

43. $f(x) = \sqrt{25 - x^2}$

44. $f(x) = -x^3 + 2$

In Exercises 45–60, for each function:

a) Determine whether it is one-to-one.

b) If the function is one-to-one, find a formula for the inverse.

45. $f(x) = x + 4$

46. $f(x) = 7 - x$

47. $f(x) = 2x - 1$

48. $f(x) = 5x + 8$

49. $f(x) = \frac{4}{x+7}$

50. $f(x) = -\frac{3}{x}$

51. $f(x) = \frac{x + 4}{x - 3}$

52. $f(x) = \frac{5x - 3}{2x + 1}$

53. $f(x) = x^3 - 1$

54. $f(x) = (x + 5)^3$

55. $f(x) = x\sqrt{4 - x^2}$

56. $f(x) = 2x^2 - x - 1$

57. $f(x) = 5x^2 - 2, x \geq 0$

58. $f(x) = 4x^2 + 3, x \geq 0$

59. $f(x) = \sqrt{x + 1}$

60. $f(x) = \sqrt[3]{x - 8}$

Find the inverse by thinking about the operations of the function and then reversing, or undoing, them. Check your work algebraically.

FUNCTION	INVERSE
61. $f(x) = 3x$	$f^{-1}(x) =$ <input type="text"/>
62. $f(x) = \frac{1}{4}x + 7$	$f^{-1}(x) =$ <input type="text"/>
63. $f(x) = -x$	$f^{-1}(x) =$ <input type="text"/>
64. $f(x) = \sqrt[3]{x} - 5$	$f^{-1}(x) =$ <input type="text"/>
65. $f(x) = \sqrt[3]{x - 5}$	$f^{-1}(x) =$ <input type="text"/>
66. $f(x) = x^{-1}$	$f^{-1}(x) =$ <input type="text"/>

Each graph in Exercises 67–72 is the graph of a one-to-one function f . Sketch the graph of the inverse function f^{-1} .

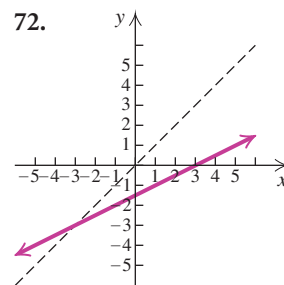
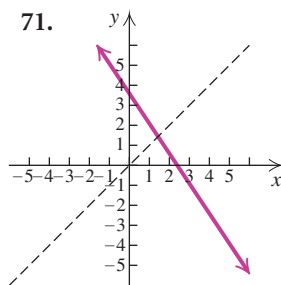
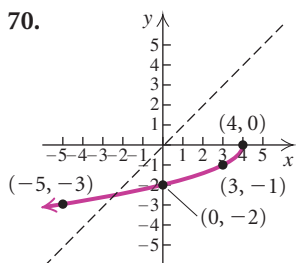
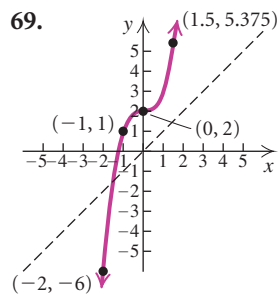
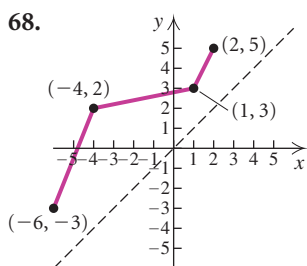
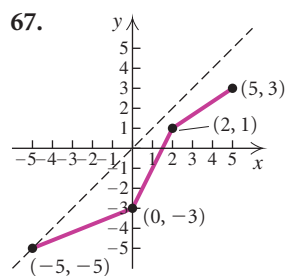

For the function f , use composition of functions to show that f^{-1} is as given.

73. $f(x) = \frac{7}{8}x, f^{-1}(x) = \frac{8}{7}x$

74. $f(x) = \frac{x + 5}{4}, f^{-1}(x) = 4x - 5$

75. $f(x) = \frac{1 - x}{x}, f^{-1}(x) = \frac{1}{x + 1}$

76. $f(x) = \sqrt[3]{x + 4}, f^{-1}(x) = x^3 - 4$

77. $f(x) = \frac{2}{5}x + 1, f^{-1}(x) = \frac{5x - 5}{2}$

78. $f(x) = \frac{x + 6}{3x - 4}, f^{-1}(x) = \frac{4x + 6}{3x - 1}$

Find the inverse of the given one-to-one function f . Give the domain and the range of f and of f^{-1} , and then graph both f and f^{-1} on the same set of axes.

79. $f(x) = 5x - 3$

80. $f(x) = 2 - x$

81. $f(x) = \frac{2}{x}$

82. $f(x) = -\frac{3}{x + 1}$

83. $f(x) = \frac{1}{3}x^3 - 2$

84. $f(x) = \sqrt[3]{x} - 1$

85. $f(x) = \frac{x + 1}{x - 3}$

86. $f(x) = \frac{x - 1}{x + 2}$

87. Find $f(f^{-1}(5))$ and $f^{-1}(f(a))$:
 $f(x) = x^3 - 4.$

88. Find $(f^{-1}(f(p)))$ and $f(f^{-1}(1253))$:
 $f(x) = \sqrt[5]{\frac{2x - 7}{3x + 4}}.$

89. **Women's Shoe Sizes.** A function that will convert women's shoe sizes in the United States to those in Australia is

$$s(x) = \frac{2x - 3}{2}$$

(Source: OnlineConversion.com).

- Determine the women's shoe sizes in Australia that correspond to sizes 5, $7\frac{1}{2}$, and 8 in the United States.
 - Find a formula for the inverse of the function.
 - Use the inverse function to determine the women's shoe sizes in the United States that correspond to sizes 3, $5\frac{1}{2}$, and 7 in Australia.
90. **Swimming Lessons.** A city swimming league determines that the cost per person of a group swim lesson is given by the formula

$$C(x) = \frac{60 + 2x}{x},$$

where x is the number of people in the group and $C(x)$ is in dollars. Find $C^{-1}(x)$ and explain what it represents.



91. **Spending on Pets.** The total amount of spending per year, in billions of dollars, on pets in the United States x years after 2000 is given by the function

$$P(x) = 2.1782x + 25.3$$

(Source: Animal Pet Products Manufacturing Association).



- Determine the total amount of spending per year on pets in 2005 and in 2010.
 - Find $P^{-1}(x)$ and explain what it represents.
92. **Converting Temperatures.** The following formula can be used to convert Fahrenheit temperatures x to Celsius temperatures $T(x)$:

$$T(x) = \frac{5}{9}(x - 32).$$

- Find $T(-13^\circ)$ and $T(86^\circ)$.
- Find $T^{-1}(x)$ and explain what it represents.

Skill Maintenance

Consider the following quadratic functions. Without graphing them, answer the questions below.

- $f(x) = 2x^2$
- $f(x) = -x^2$
- $f(x) = \frac{1}{4}x^2$
- $f(x) = -5x^2 + 3$
- $f(x) = \frac{2}{3}(x - 1)^2 - 3$
- $f(x) = -2(x + 3)^2 + 1$
- $f(x) = (x - 3)^2 + 1$
- $f(x) = -4(x + 1)^2 - 3$

- Which functions have a maximum value?
- Which graphs open up?
- Consider (a) and (c). Which graph is narrower?
- Consider (d) and (e). Which graph is narrower?

97. Which graph has vertex $(-3, 1)$?
98. For which is the line of symmetry $x = 0$?

Synthesis

99. The function $f(x) = x^2 - 3$ is not one-to-one. Restrict the domain of f so that its inverse is a function. Find the inverse and state the restriction on the domain of the inverse.

100. Consider the function f given by

$$f(x) = \begin{cases} x^3 + 2, & \text{for } x \leq -1, \\ x^2, & \text{for } -1 < x < 1, \\ x + 1, & \text{for } x \geq 1. \end{cases}$$

Does f have an inverse that is a function? Why or why not?

101. Find three examples of functions that are their own inverses; that is, $f = f^{-1}$.
102. Given the function $f(x) = ax + b$, $a \neq 0$, find the values of a and b for which $f^{-1}(x) = f(x)$.

Exponential Functions and Graphs

5.2

- ▶ Graph exponential equations and exponential functions.
- ▶ Solve applied problems involving exponential functions and their graphs.

We now turn our attention to the study of a set of functions that are very rich in application. Consider the following graphs. Each one illustrates an *exponential function*. In this section, we consider such functions and some important applications.

Cost of a Funeral for an Adult

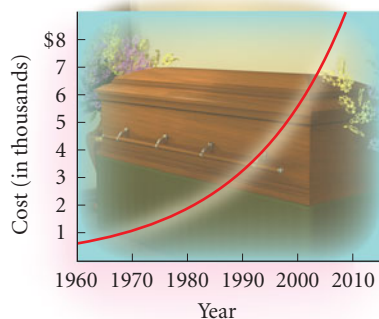

Source: National Funeral Association Directors

Wind Energy Capacity in the United States

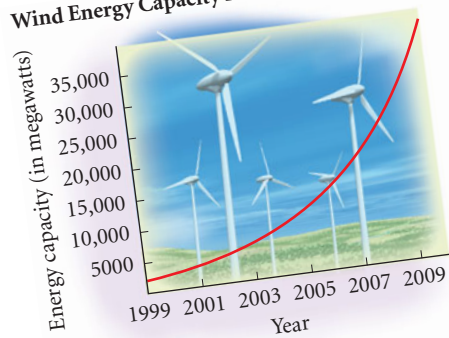

Source: Office of Energy Efficiency and Renewable Energy

Expenses for the Census Count

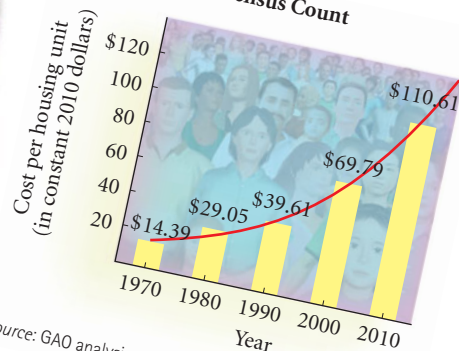

Source: GAO analysis of U.S. Census Bureau data

EXPONENTS

REVIEW SECTIONS R.2 AND R.7

▶ Graphing Exponential Functions

We now define exponential functions. We assume that a^x has meaning for any real number x and any positive real number a and that the laws of exponents still hold, though we will not prove them here.

Exponential Function

The function $f(x) = a^x$, where x is a real number, $a > 0$ and $a \neq 1$, is called the **exponential function**, base a .

We require the **base** to be positive in order to avoid the imaginary numbers that would occur by taking even roots of negative numbers—an example is $(-1)^{1/2}$, the square root of -1 , which is not a real number. The restriction $a \neq 1$ is made to exclude the constant function $f(x) = 1^x = 1$, which does not have an inverse that is a function because it is not one-to-one.

The following are examples of exponential functions:

$$f(x) = 2^x, \quad f(x) = \left(\frac{1}{2}\right)^x, \quad f(x) = (3.57)^x.$$

Note that, in contrast to functions like $f(x) = x^5$ and $f(x) = x^{1/2}$ in which the variable is the base of an exponential expression, the variable in an exponential function is *in the exponent*.

Let's now consider graphs of exponential functions.

EXAMPLE 1 Graph the exponential function

$$y = f(x) = 2^x.$$

Solution We compute some function values and list the results in a table.

$$\begin{aligned} f(0) &= 2^0 = 1; & f(-1) &= 2^{-1} = \frac{1}{2^1} = \frac{1}{2}; \\ f(1) &= 2^1 = 2; & f(2) &= 2^2 = 4; & f(-2) &= 2^{-2} = \frac{1}{2^2} = \frac{1}{4}; \\ f(3) &= 2^3 = 8; & f(-3) &= 2^{-3} = \frac{1}{2^3} = \frac{1}{8}. \end{aligned}$$

Next, we plot these points and connect them with a smooth curve. Be sure to plot enough points to determine how steeply the curve rises.

x	y	(x, y)
	$y = f(x) = 2^x$	
0	1	(0, 1)
1	2	(1, 2)
2	4	(2, 4)
3	8	(3, 8)
-1	$\frac{1}{2}$	$(-1, \frac{1}{2})$
-2	$\frac{1}{4}$	$(-2, \frac{1}{4})$
-3	$\frac{1}{8}$	$(-3, \frac{1}{8})$

The curve comes very close to the x -axis, but does not touch or cross it.

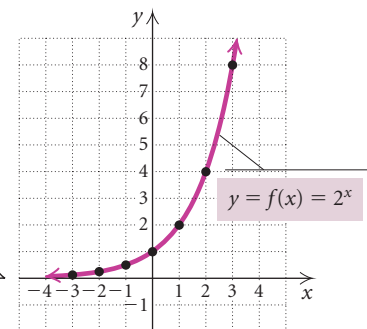

HORIZONTAL ASYMPTOTES

REVIEW SECTION 4.5

Note that as x increases, the function values increase without bound. As x decreases, the function values decrease, getting close to 0. That is, as $x \rightarrow -\infty$, $y \rightarrow 0$. Thus the x -axis, or the line $y = 0$, is a horizontal asymptote. As the x -inputs decrease, the curve gets closer and closer to this line, but does not cross it.

➔ Now Try Exercise 11.

EXAMPLE 2 Graph the exponential function $y = f(x) = \left(\frac{1}{2}\right)^x$.

Solution Before we plot points and draw the curve, note that

$$y = f(x) = \left(\frac{1}{2}\right)^x = (2^{-1})^x = 2^{-x}.$$

This tells us that this graph is a reflection of the graph of $y = 2^x$ across the y -axis. For example, if $(3, 8)$ is a point of the graph of $g(x) = 2^x$, then $(-3, 8)$ is a point of the graph of $f(x) = 2^{-x}$. Selected points are listed in the table at left.

Next, we plot these points and connect them with a smooth curve.

Points of $g(x) = 2^x$	Points of $f(x) = \left(\frac{1}{2}\right)^x = 2^{-x}$
$(0, 1)$	$(0, 1)$
$(1, 2)$	$(-1, 2)$
$(2, 4)$	$(-2, 4)$
$(3, 8)$	$(-3, 8)$
$\left(-1, \frac{1}{2}\right)$	$\left(1, \frac{1}{2}\right)$
$\left(-2, \frac{1}{4}\right)$	$\left(2, \frac{1}{4}\right)$
$\left(-3, \frac{1}{8}\right)$	$\left(3, \frac{1}{8}\right)$

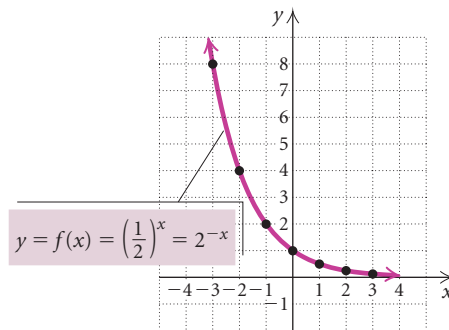

Note that as x increases, the function values decrease, getting close to 0. The x -axis, $y = 0$, is the horizontal asymptote. As x decreases, the function values increase without bound.

➔ Now Try Exercise 15.

Observe the following graphs of exponential functions and look for patterns in them.

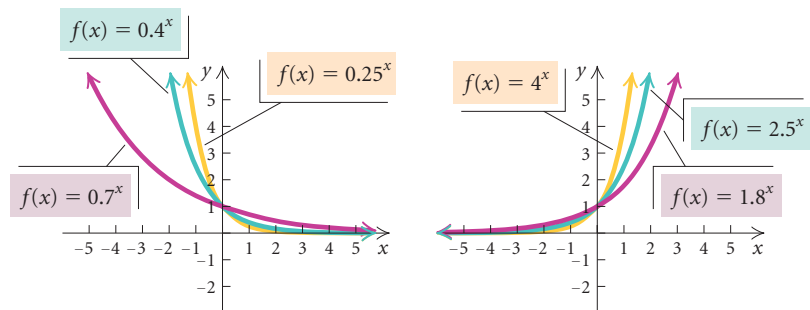

What relationship do you see between the base a and the shape of the resulting graph of $f(x) = a^x$? What do all the graphs have in common? How do they differ?

CONNECTING THE CONCEPTS

Properties of Exponential Functions

Let's list and compare some characteristics of exponential functions, keeping in mind that the definition of an exponential function, $f(x) = a^x$, requires that a be positive and different from 1.

$$f(x) = a^x, a > 0, a \neq 1$$

Continuous

One-to-one

Domain: $(-\infty, \infty)$

Range: $(0, \infty)$

Increasing if $a > 1$

Decreasing if $0 < a < 1$

Horizontal asymptote is x -axis

y -intercept: $(0, 1)$

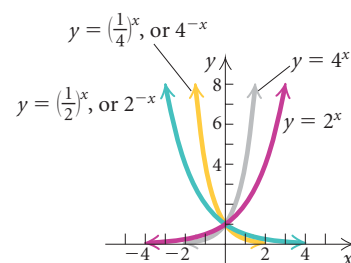

TRANSFORMATIONS OF FUNCTIONS

REVIEW SECTION 2.4

To graph other types of exponential functions, keep in mind the ideas of translation, stretching, and reflection. All these concepts allow us to visualize the graph before drawing it.

EXAMPLE 3 Graph each of the following. Before doing so, describe how each graph can be obtained from the graph of $f(x) = 2^x$.

a) $f(x) = 2^{x-2}$ b) $f(x) = 2^x - 4$ c) $f(x) = 5 - 0.5^x$

Solution

a) The graph of $f(x) = 2^{x-2}$ is the graph of $y = 2^x$ shifted *right* 2 units.

x	$f(x)$
-1	$\frac{1}{8}$
0	$\frac{1}{4}$
1	$\frac{1}{2}$
2	1
3	2
4	4
5	8

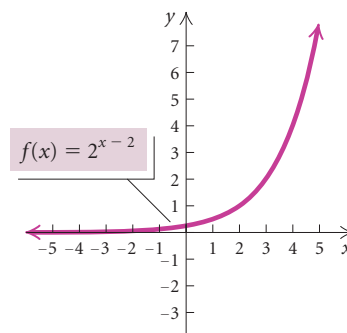

- b) The graph of $f(x) = 2^x - 4$ is the graph of $y = 2^x$ shifted *down* 4 units.

x	$f(x)$
-2	$-3\frac{3}{4}$
-1	$-3\frac{1}{2}$
0	-3
1	-2
2	0
3	4

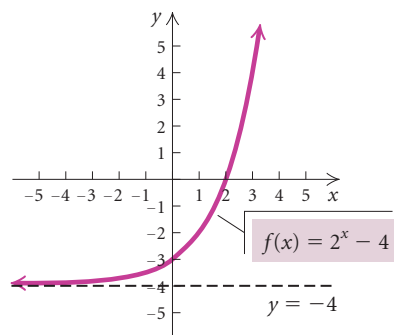

- c) The graph of $f(x) = 5 - 0.5^x = 5 - \left(\frac{1}{2}\right)^x = 5 - 2^{-x}$ is a reflection of the graph of $y = 2^x$ across the y -axis, followed by a reflection across the x -axis and then a shift *up* 5 units.

x	$f(x)$
-3	-3
-2	1
-1	3
0	4
1	$4\frac{1}{2}$
2	$4\frac{3}{4}$

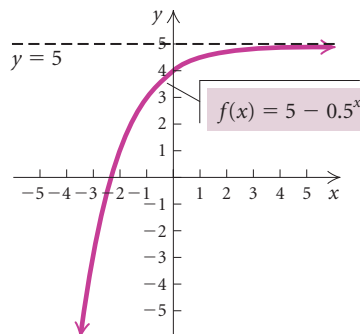

➔ Now Try Exercises 27 and 33.

► Applications

One of the most frequent applications of exponential functions occurs with compound interest.

EXAMPLE 4 *Compound Interest.* The amount of money A to which a principal P will grow after t years at interest rate r (in decimal form), compounded n times per year, is given by the formula

$$A = P \left(1 + \frac{r}{n} \right)^{nt}.$$

Suppose that \$100,000 is invested at 6.5% interest, compounded semiannually.

- Find a function for the amount to which the investment grows after t years.
- Find the amount of money in the account at $t = 0, 4, 8,$ and 10 years.
- Graph the function.

TECHNOLOGY CONNECTION

We can find the function values in Example 4(b) using the VALUE feature from the CALC menu.

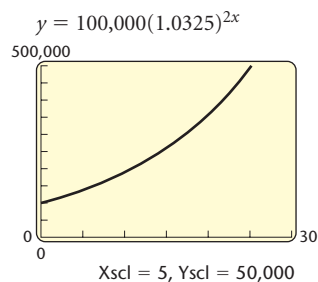

We could also use the TABLE feature.

Solution

- a) Since $P = \$100,000$, $r = 6.5\% = 0.065$, and $n = 2$, we can substitute these values and write the following function:

$$A(t) = 100,000 \left(1 + \frac{0.065}{2} \right)^{2 \cdot t} = \$100,000(1.0325)^{2t}.$$

- b) We can compute function values with a calculator:

$$A(0) = 100,000(1.0325)^{2 \cdot 0} = \$100,000;$$

$$A(4) = 100,000(1.0325)^{2 \cdot 4} \approx \$129,157.75;$$

$$A(8) = 100,000(1.0325)^{2 \cdot 8} \approx \$166,817.25;$$

$$A(10) = 100,000(1.0325)^{2 \cdot 10} \approx \$189,583.79.$$

- c) We use the function values computed in part (b) and others if we wish, and draw the graph as follows. Note that the axes are scaled differently because of the large values of A and that t is restricted to nonnegative values, because negative time values have no meaning here.

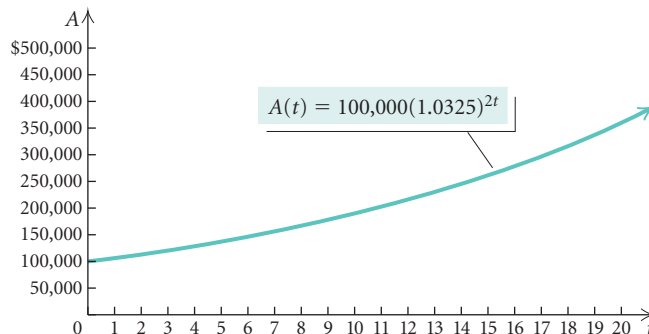

Now Try Exercise 51.

► The Number e

We now consider a very special number in mathematics. In 1741, Leonhard Euler named this number e . Though you may not have encountered it before, you will see here and in future mathematics courses that it has many important applications. To explain this number, we use the compound interest formula $A = P(1 + r/n)^{nt}$ discussed in Example 4. Suppose that \$1 is invested at 100% interest for 1 year. Since $P = 1$, $r = 100\% = 1$, and $t = 1$, the formula above becomes a function A defined in terms of the number of compounding periods n :

$$A = P \left(1 + \frac{r}{n} \right)^{nt} = 1 \left(1 + \frac{1}{n} \right)^{n \cdot 1} = \left(1 + \frac{1}{n} \right)^n.$$

Let's visualize this function with its graph shown at left and explore the values of $A(n)$ as $n \rightarrow \infty$. Consider the graph for larger and larger values of n . Does this function have a horizontal asymptote?

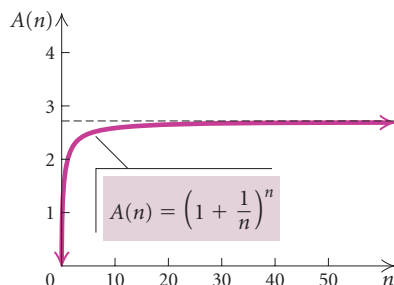

Let's find some function values using a calculator.

n , Number of Compounding Periods	$A(n) = \left(1 + \frac{1}{n}\right)^n$
1 (compounded annually)	\$2.00
2 (compounded semiannually)	2.25
3	2.3704
4 (compounded quarterly)	2.4414
5	2.4883
100	2.7048
365 (compounded daily)	2.7146
8760 (compounded hourly)	2.7181

It appears from these values that the graph does have a horizontal asymptote, $y \approx 2.7$. As the values of n get larger and larger, the function values get closer and closer to the number Euler named e . Its decimal representation does not terminate or repeat; it is irrational.

$$e = 2.7182818284 \dots$$

EXAMPLE 5 Find each value of e^x , to four decimal places, using the e^x key on a calculator.

a) e^3

b) $e^{-0.23}$

c) e^0

d) e^1

Solution

FUNCTION VALUE	READOUT	ROUNDED
a) e^3	$e^{(3)}$ 20.08553692	20.0855
b) $e^{-0.23}$	$e^{(-.23)}$.7945336025	0.7945
c) e^0	$e^{(0)}$ 1	1
d) e^1	$e^{(1)}$ 2.718281828	2.7183

 **Now Try Exercises 1 and 3.**

► Graphs of Exponential Functions, Base e

We demonstrate ways in which to graph exponential functions.

EXAMPLE 6 Graph $f(x) = e^x$ and $g(x) = e^{-x}$.

Solution We can compute points for each equation using the (e^x) key on a calculator. (See the table below.) Then we plot these points and draw the graphs of the functions.

x	$f(x) = e^x$	$g(x) = e^{-x}$
-2	0.135	7.389
-1	0.368	2.718
0	1	1
1	2.718	0.368
2	7.389	0.135

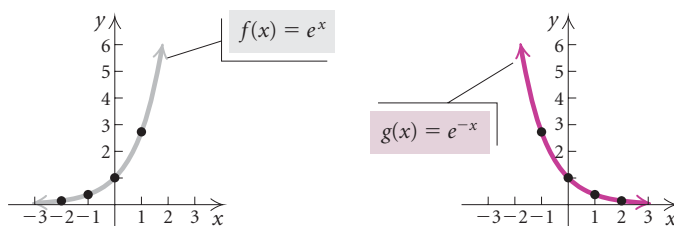

Note that the graph of g is a reflection of the graph of f across the y -axis.

➔ Now Try Exercise 23.

EXAMPLE 7 Graph each of the following. Before doing so, describe how each graph can be obtained from the graph of $y = e^x$.

- a) $f(x) = e^{x+3}$ b) $f(x) = e^{-0.5x}$ c) $f(x) = 1 - e^{-2x}$

Solution

- a) The graph of $f(x) = e^{x+3}$ is a translation of the graph of $y = e^x$ left 3 units.

x	$f(x)$
-7	0.018
-5	0.135
-3	1
-1	7.389
0	20.086

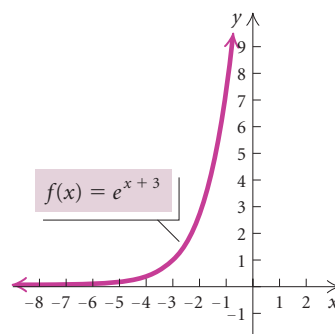

- b) We note that the graph of $f(x) = e^{-0.5x}$ is a horizontal stretching of the graph of $y = e^x$ followed by a reflection across the y -axis.

x	$f(x)$
-2	2.718
-1	1.649
0	1
1	0.607
2	0.368

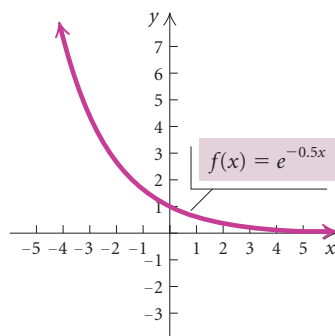

- c) The graph of $f(x) = 1 - e^{-2x}$ is a horizontal shrinking of the graph of $y = e^x$, followed by a reflection across the y -axis, then across the x -axis, and followed by a translation up 1 unit.

x	$f(x)$
-1	-6.389
0	0
1	0.865
2	0.982
3	0.998

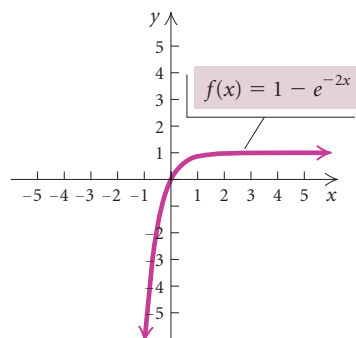

➔ Now Try Exercises 41 and 47.

5.2

Exercise Set

Find each of the following, to four decimal places, using a calculator.

1. e^4

2. e^{10}

3. $e^{-2.458}$

4. $\left(\frac{1}{e^3}\right)^2$

In Exercises 5–10, match the function with one of the graphs (a)–(f), which follow.

5. $f(x) = -2^x - 1$

6. $f(x) = -\left(\frac{1}{2}\right)^x$

7. $f(x) = e^x + 3$

8. $f(x) = e^{x+1}$

9. $f(x) = 3^{-x} - 2$

a)

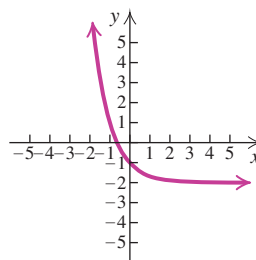

10. $f(x) = 1 - e^x$

b)

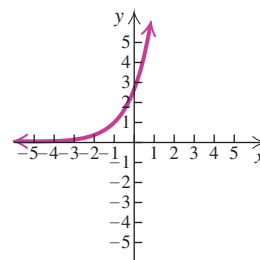

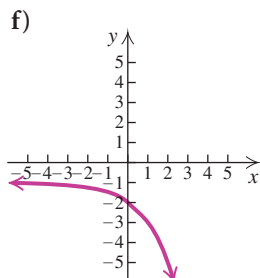
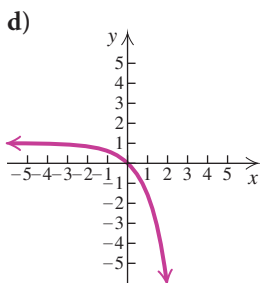
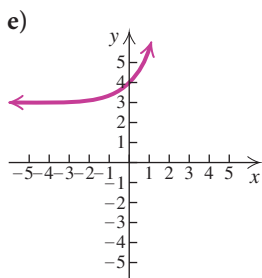
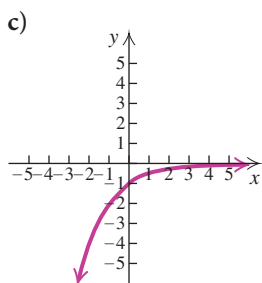

Graph the function by substituting and plotting points.

- | | |
|---|---|
| 11. $f(x) = 3^x$ | 12. $f(x) = 5^x$ |
| 13. $f(x) = 6^x$ | 14. $f(x) = 3^{-x}$ |
| 15. $f(x) = \left(\frac{1}{4}\right)^x$ | 16. $f(x) = \left(\frac{2}{3}\right)^x$ |
| 17. $y = -2^x$ | 18. $y = 3 - 3^x$ |
| 19. $f(x) = -0.25^x + 4$ | 20. $f(x) = 0.6^x - 3$ |
| 21. $f(x) = 1 + e^{-x}$ | 22. $f(x) = 2 - e^{-x}$ |
| 23. $y = \frac{1}{4}e^x$ | 24. $y = 2e^{-x}$ |
| 25. $f(x) = 1 - e^{-x}$ | 26. $f(x) = e^x - 2$ |

Sketch the graph of the function. Describe how each graph can be obtained from the graph of a basic exponential function.

- | | |
|---|----------------------------------|
| 27. $f(x) = 2^{x+1}$ | 28. $f(x) = 2^{x-1}$ |
| 29. $f(x) = 2^x - 3$ | 30. $f(x) = 2^x + 1$ |
| 31. $f(x) = 2^{1-x} + 2$ | 32. $f(x) = 5 - 2^{-x}$ |
| 33. $f(x) = 4 - 3^{-x}$ | 34. $f(x) = 2^{x-1} - 3$ |
| 35. $f(x) = \left(\frac{3}{2}\right)^{x-1}$ | 36. $f(x) = 3^{4-x}$ |
| 37. $f(x) = 2^{x+3} - 5$ | 38. $f(x) = -3^{x-2}$ |
| 39. $f(x) = 3 \cdot 2^{x-1} + 1$ | 40. $f(x) = 2 \cdot 3^{x+1} - 2$ |

41. $f(x) = e^{2x}$

42. $f(x) = e^{-0.2x}$

43. $f(x) = \frac{1}{2}(1 - e^x)$

44. $f(x) = 3(1 + e^x) - 3$

45. $y = e^{-x+1}$

46. $y = e^{2x} + 1$

47. $f(x) = 2(1 - e^{-x})$

48. $f(x) = 1 - e^{-0.01x}$

Graph the piecewise function.

$$49. f(x) = \begin{cases} e^{-x} - 4, & \text{for } x < -2, \\ x + 3, & \text{for } -2 \leq x < 1, \\ x^2, & \text{for } x \geq 1 \end{cases}$$

$$50. g(x) = \begin{cases} 4, & \text{for } x \leq -3, \\ x^2 - 6, & \text{for } -3 < x < 0, \\ e^x, & \text{for } x \geq 0 \end{cases}$$

51. **Compound Interest.** Suppose that \$82,000 is invested at $4\frac{1}{2}\%$ interest, compounded quarterly.
- Find the function for the amount to which the investment grows after t years.
 - Find the amount of money in the account at $t = 0, 2, 5,$ and 10 years.
52. **Compound Interest.** Suppose that \$750 is invested at 7% interest, compounded semiannually.
- Find the function for the amount to which the investment grows after t years.
 - Find the amount of money in the account at $t = 1, 6, 10, 15,$ and 25 years.
53. **Interest on a CD.** On Will's sixth birthday, his grandparents present him with a \$3000 certificate of deposit (CD) that earns 5% interest, compounded quarterly. If the CD matures on his sixteenth birthday, what amount will be available then?
54. **Interest in a College Trust Fund.** Following the birth of her child, Sophia deposits \$10,000 in a college trust fund where interest is 3.9%, compounded semiannually.
- Find a function for the amount in the account after t years.
 - Find the amount of money in the account at $t = 0, 4, 8, 10, 18,$ and 21 years.

In Exercises 55–62, use the compound-interest formula to find the account balance A with the given conditions:

- P = principal,
 r = interest rate,
 n = number of compounding periods per year,
 t = time, in years,
 A = account balance.

	P	r	Compounded	n	t	A
55.	\$3,000	4%	Semiannually		2	
56.	\$12,500	3%	Quarterly		3	
57.	\$120,000	2.5%	Annually		10	
58.	\$120,000	2.5%	Quarterly		10	
59.	\$53,500	$5\frac{1}{2}\%$	Quarterly		$6\frac{1}{2}$	
60.	\$6,250	$6\frac{3}{4}\%$	Semiannually		$4\frac{1}{2}$	
61.	\$17,400	8.1%	Daily		5	
62.	\$900	7.3%	Daily		$7\frac{1}{4}$	

63. **Overweight Troops.** The number of U.S. troops diagnosed as overweight has more than doubled since 1998 (*Source*: U.S. Department of Defense). The exponential function

$$W(x) = 23,672.16(1.112)^x,$$

where x is the number of years since 1998, can be used to estimate the number of overweight active troops. Find the number of overweight troops in 2000 and in 2008. Then project the number of overweight troops in 2011.



64. **Foreign Students from India.** The number of students from India enrolled in U.S. colleges and universities has grown exponentially from about 9000 in 1980 to about 95,000 in 2008 (*Source*: Institute of International Education, New York). The exponential function

$$I(t) = 9000(1.0878)^t,$$

where t is the number of years since 1980, can be used to estimate the number of students from India enrolled in U.S. colleges and universities. Find the number of students from India enrolled in 1985, in 1999, and in 2006. Then use the function to predict the number of students from India enrolled in 2012.

65. **IRS Tax Code.** The number of pages in the IRS Tax Code has increased from 400 pages in 1913 to 70,320 pages in 2009 (*Source*: IRS). The increase can be modeled by the exponential function

$$T(x) = 400(1.055)^x,$$

where x is the number of years since 1913. Use this function to estimate the number of pages in the tax code for 1950, for 1990, and for 2000. Round to the nearest one.

66. **Medicare Premiums.** The monthly Medicare Part B health-care premium for most beneficiaries 65 and older has increased significantly since 1975. The monthly premium has increased from about \$7 in 1975 to \$110.50 in 2010 (*Source*: Centers for Medicare and Medicaid Services). The following exponential function models the premium increases:

$$M(x) = 7(1.082)^x,$$

where x is the number of years since 1975. Estimate the monthly Medicare Part B premium in 1985, in 1992, and in 2002. Round to the nearest dollar.

67. **Taxi Medallions.** The business of taxi medallions, required licenses fastened to the hood of all New York City cabs, has proven itself to be a valuable investment. The average price for a corporate-license taxi medallion in New York has risen from about \$200,000 in 2001 to \$753,000 in 2009 (*Sources*: New York City Taxi & Limousine Commission; Andrew Murstein, president of Medallion Financial). The exponential function

$$M(x) = 200,000(1.1802)^x,$$

where x is the number of years since 2001, models the data for the average price of a medallion in recent years. Estimate the price of a taxi medallion in 2003

and in 2007. Then use the function to project the average price in 2013. Round to the nearest dollar.



68. **Cost of Census.** The cost per household for taking the U.S. census has increased exponentially since 1970 (Source: GAO analysis of U.S. Census Bureau data). The following function models the increase in cost:

$$C(x) = 15.5202(1.0508)^x,$$

where x is the number of years since 1970. Estimate the cost per household in 1990 and in 2010.

69. **Recycling Plastic Bags.** It is estimated that 90 billion plastic carry-out bags are produced annually in the United States. In recent years, the number of tons of plastic bags that are recycled has grown exponentially from approximately 80,000 tons in 1996 to 380,000 tons in 2007 (Source: Environmental Protection Agency).

The following exponential function models the amount recycled, in tons:

$$R(x) = 80,000(1.1522)^x,$$

where x is the number of years since 1996. Find the total amount recycled, in tons, in 1999 and in 2007. Then use the function to estimate the total number of tons that will be recycled in 2012.

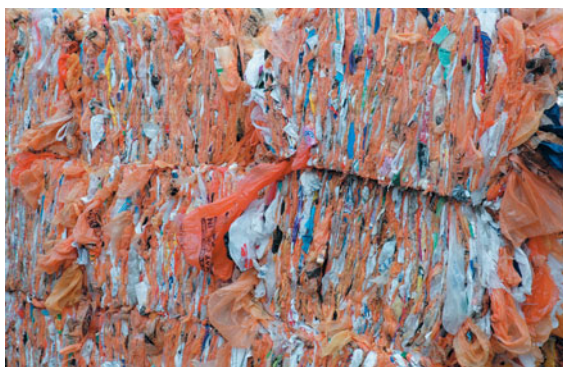

70. **Master's Degrees Earned by Women.** The function

$$D(t) = 43.1224(1.0475)^t$$

gives the number of master's degrees, in thousands, conferred on women in the United States t years after 1960 (Sources: National Center for Educational Statistics; Digest of Education Statistics). Find the number of master's degrees earned by women in 1984, in 2002, and in 2010. Then estimate the number of master's degrees that will be earned by women in 2015.

71. **Tennis Participation.** In recent years, U.S. tennis participation has increased. The function

$$T(x) = 23.7624(1.0752)^x,$$

where $T(x)$ is in millions and x is the number of years since 2006, models the number of people who had played tennis at least once (Source: USTA/Coyne Public Relations). Estimate the number who had played tennis at least once in a year for 2007. Then use this function to project participation in tennis in 2014.



72. **Growth of Bacteria Escherichia coli.** The bacteria *Escherichia coli* are commonly found in the human intestines. Suppose that 3000 of the bacteria are present at time $t = 0$. Then under certain conditions, t minutes later, the number of bacteria present is

$$N(t) = 3000(2)^{t/20}.$$

How many bacteria will be present after 10 min? 20 min? 30 min? 40 min? 60 min?

73. **Salvage Value.** A landscape company purchased a backhoe for \$56,395. The value of the backhoe each year is 90% of the value of the preceding year. After

t years, its value, in dollars, is given by the exponential function

$$V(t) = 56,395(0.9)^t.$$

Find the value of the backhoe after 0, 1, 3, 6, and 10 years. Round to the nearest dollar.



74. **Typing Speed.** Sarah is taking keyboarding at a community college. After she practices for t hours, her speed, in words per minute, is given by the function

$$S(t) = 200[1 - (0.86)^t].$$

What is Sarah's speed after practicing for 10 hr? 20 hr? 40 hr? 100 hr?

75. **Advertising.** A company begins a radio advertising campaign in New York City to market a new video game. The percentage of the target market that buys a game is generally a function of the length of the advertising campaign. The estimated percentage is given by

$$f(t) = 100(1 - e^{-0.04t}),$$

where t is the number of days of the campaign. Find $f(25)$, the percentage of the target market that has bought the product after a 25-day advertising campaign.

76. **Growth of a Stock.** The value of a stock is given by the function

$$V(t) = 58(1 - e^{-1.1t}) + 20,$$

where V is the value of the stock after time t , in months. Find $V(1)$, $V(2)$, $V(4)$, $V(6)$, and $V(12)$.

Skill Maintenance

Simplify.

77. $(1 - 4i)(7 + 6i)$

78. $\frac{2 - i}{3 + i}$

Find the x -intercepts and the zeros of the function.

79. $f(x) = 2x^2 - 13x - 7$

80. $h(x) = x^3 - 3x^2 + 3x - 1$

81. $h(x) = x^4 - x^2$

82. $g(x) = x^3 + x^2 - 12x$

Solve.

83. $x^3 + 6x^2 - 16x = 0$

84. $3x^2 - 6 = 5x$

Synthesis

85. Which is larger, 7^π or π^7 ? 70^{80} or 80^{70} ?
86. For the function f , construct and simplify the difference quotient. (See Section 2.2 for review.)

$$f(x) = 2e^x - 3$$

Logarithmic Functions and Graphs

5.3

- ▶ Find common logarithms and natural logarithms with and without a calculator.
- ▶ Convert between exponential equations and logarithmic equations.
- ▶ Change logarithmic bases.
- ▶ Graph logarithmic functions.
- ▶ Solve applied problems involving logarithmic functions.

We now consider *logarithmic*, or *logarithm*, *functions*. These functions are inverses of exponential functions and have many applications.

▶ Logarithmic Functions

We have noted that every exponential function (with $a > 0$ and $a \neq 1$) is one-to-one. Thus such a function has an inverse that is a function. In this section, we will name these inverse functions logarithmic functions and use them in applications. We can draw the graph of the inverse of an exponential function by interchanging x and y .

EXAMPLE 1 Graph: $x = 2^y$.

Solution Note that x is alone on one side of the equation. We can find ordered pairs that are solutions by choosing values for y and then computing the corresponding x -values.

$$\text{For } y = 0, x = 2^0 = 1.$$

$$\text{For } y = 1, x = 2^1 = 2.$$

$$\text{For } y = 2, x = 2^2 = 4.$$

$$\text{For } y = 3, x = 2^3 = 8.$$

$$\text{For } y = -1, x = 2^{-1} = \frac{1}{2^1} = \frac{1}{2}.$$

$$\text{For } y = -2, x = 2^{-2} = \frac{1}{2^2} = \frac{1}{4}.$$

$$\text{For } y = -3, x = 2^{-3} = \frac{1}{2^3} = \frac{1}{8}.$$

x		
$x = 2^y$	y	(x, y)
1	0	(1, 0)
2	1	(2, 1)
4	2	(4, 2)
8	3	(8, 3)
$\frac{1}{2}$	-1	$(\frac{1}{2}, -1)$
$\frac{1}{4}$	-2	$(\frac{1}{4}, -2)$
$\frac{1}{8}$	-3	$(\frac{1}{8}, -3)$

- ↑ (1) Choose values for y .
 ↑ (2) Compute values for x .

We plot the points and connect them with a smooth curve. Note that the curve does not touch or cross the y -axis. The y -axis is a vertical asymptote.

Note too that this curve looks just like the graph of $y = 2^x$, except that it is reflected across the line $y = x$, as we would expect for an inverse. The inverse of $y = 2^x$ is $x = 2^y$.

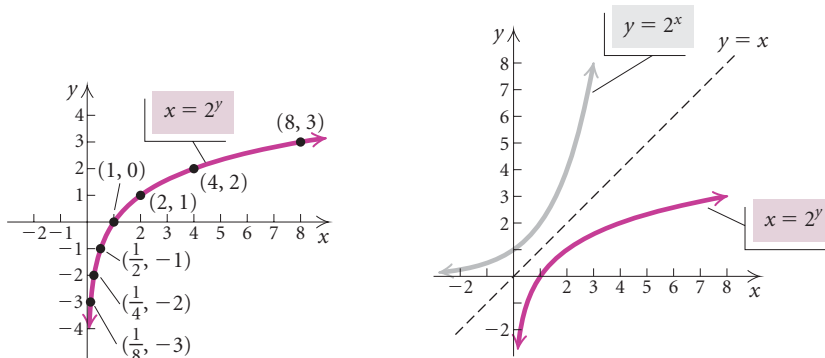

➔ Now Try Exercise 1.

To find a formula for f^{-1} when $f(x) = 2^x$, we try to use the method of Section 5.1:

1. Replace $f(x)$ with y : $y = 2^x$
2. Interchange x and y : $x = 2^y$
3. Solve for y : $y =$ the power to which we raise 2 to get x .
4. Replace y with $f^{-1}(x)$: $f^{-1}(x) =$ the power to which we raise 2 to get x .

Mathematicians have defined a new symbol to replace the words “the power to which we raise 2 to get x .” That symbol is “ $\log_2 x$,” read “the logarithm, base 2, of x .”

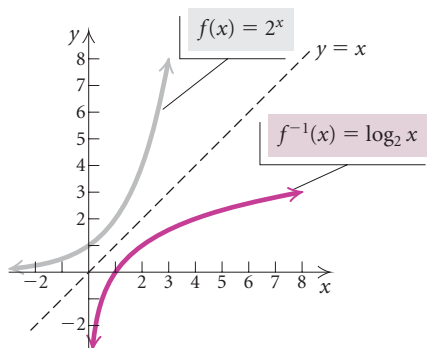

Logarithmic Function, Base 2

“ $\log_2 x$,” read “the logarithm, base 2, of x ,” means “the power to which we raise 2 to get x .”

Thus if $f(x) = 2^x$, then $f^{-1}(x) = \log_2 x$. For example,

$$f^{-1}(8) = \log_2 8 = 3,$$

because

3 is the power to which we raise 2 to get 8.

Similarly, $\log_2 13$ is the power to which we raise 2 to get 13. As yet, we have no simpler way to say this other than

“ $\log_2 13$ is the power to which we raise 2 to get 13.”

Later, however, we will learn how to approximate this expression using a calculator.

For any exponential function $f(x) = a^x$, its inverse is called a **logarithmic function, base a** . The graph of the inverse can be obtained by reflecting the graph of $y = a^x$ across the line $y = x$, to obtain $x = a^y$. Then $x = a^y$ is equivalent to $y = \log_a x$. We read $\log_a x$ as “the logarithm, base a , of x .”

The inverse of $f(x) = a^x$ is given by $f^{-1}(x) = \log_a x$.

STUDY TIP

Try being a tutor for a fellow student. Understanding and retention of concepts can be enhanced when you explain the material to someone else.

Logarithmic Function, Base a

We define $y = \log_a x$ as that number y such that $x = a^y$, where $x > 0$ and a is a positive constant other than 1.

Let's look at the graphs of $f(x) = a^x$ and $f^{-1}(x) = \log_a x$ for $a > 1$ and $0 < a < 1$.

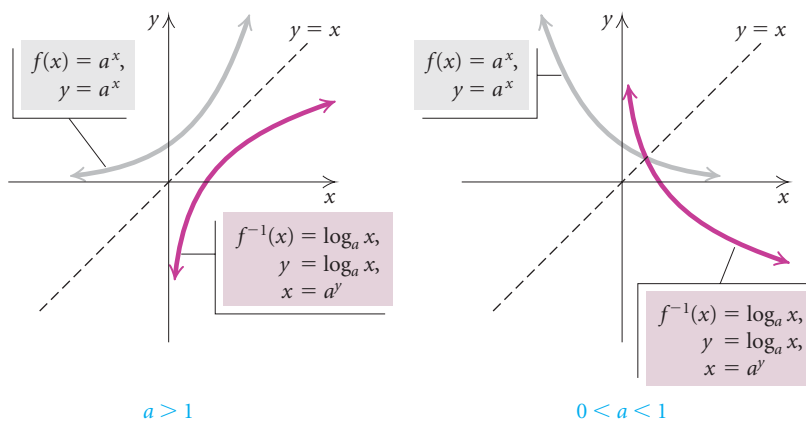

Note that the graphs of $f(x)$ and $f^{-1}(x)$ are reflections of each other across the line $y = x$.

CONNECTING THE CONCEPTS

Comparing Exponential Functions and Logarithmic Functions

In the following table, we compare exponential functions and logarithmic functions with bases a greater than 1. Similar statements could be made for a , where $0 < a < 1$. It is helpful to visualize the differences by carefully observing the graphs.

EXPONENTIAL FUNCTION

$$y = a^x$$

$$f(x) = a^x$$

$$a > 1$$

Continuous

One-to-one

Domain: All real numbers, $(-\infty, \infty)$

Range: All positive real numbers, $(0, \infty)$

Increasing

Horizontal asymptote is x -axis:
($a^x \rightarrow 0$ as $x \rightarrow -\infty$)

y -intercept: $(0, 1)$

There is no x -intercept.

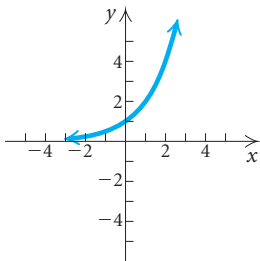

LOGARITHMIC FUNCTION

$$x = a^y$$

$$f^{-1}(x) = \log_a x$$

$$a > 1$$

Continuous

One-to-one

Domain: All positive real numbers, $(0, \infty)$

Range: All real numbers, $(-\infty, \infty)$

Increasing

Vertical asymptote is y -axis:
($\log_a x \rightarrow -\infty$ as $x \rightarrow 0^+$)

x -intercept: $(1, 0)$

There is no y -intercept.

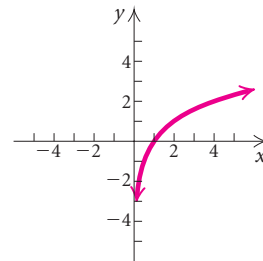

Finding Certain Logarithms

Let's use the definition of logarithms to find some logarithmic values.

EXAMPLE 2 Find each of the following logarithms.

- a) $\log_{10} 10,000$ b) $\log_{10} 0.01$ c) $\log_2 8$
 d) $\log_9 3$ e) $\log_6 1$ f) $\log_8 8$

Solution

- a) The exponent to which we raise 10 to obtain 10,000 is 4; thus $\log_{10} 10,000 = 4$.
- b) We have $0.01 = \frac{1}{100} = \frac{1}{10^2} = 10^{-2}$. The exponent to which we raise 10 to get 0.01 is -2 , so $\log_{10} 0.01 = -2$.
- c) $8 = 2^3$. The exponent to which we raise 2 to get 8 is 3, so $\log_2 8 = 3$.
- d) $3 = \sqrt{9} = 9^{1/2}$. The exponent to which we raise 9 to get 3 is $\frac{1}{2}$, so $\log_9 3 = \frac{1}{2}$.
- e) $1 = 6^0$. The exponent to which we raise 6 to get 1 is 0, so $\log_6 1 = 0$.
- f) $8 = 8^1$. The exponent to which we raise 8 to get 8 is 1, so $\log_8 8 = 1$.

➔ Now Try Exercise 9.

Examples 2(e) and 2(f) illustrate two important properties of logarithms. The property $\log_a 1 = 0$ follows from the fact that $a^0 = 1$. Thus, $\log_5 1 = 0$, $\log_{10} 1 = 0$, and so on. The property $\log_a a = 1$ follows from the fact that $a^1 = a$. Thus, $\log_5 5 = 1$, $\log_{10} 10 = 1$, and so on.

$$\log_a 1 = 0 \quad \text{and} \quad \log_a a = 1, \quad \text{for any logarithmic base } a.$$

► Converting Between Exponential Equations and Logarithmic Equations

It is helpful in dealing with logarithmic functions to remember that a logarithm of a number is an *exponent*. It is the exponent y in $x = a^y$. You might think to yourself, “the logarithm, base a , of a number x is the power to which a must be raised to get x .”

We are led to the following. (The symbol \leftrightarrow means that the two statements are equivalent; that is, when one is true, the other is true. The words “if and only if” can be used in place of \leftrightarrow .)

$$\log_a x = y \leftrightarrow x = a^y \quad \text{A logarithm is an exponent!}$$

EXAMPLE 3 Convert each of the following to a logarithmic equation.

a) $16 = 2^x$ b) $10^{-3} = 0.001$ c) $e^t = 70$

Solution

a) $16 = 2^x \rightarrow \log_2 16 = x$



b) $10^{-3} = 0.001 \rightarrow \log_{10} 0.001 = -3$

c) $e^t = 70 \rightarrow \log_e 70 = t$

➔ Now Try Exercise 37.

EXAMPLE 4 Convert each of the following to an exponential equation.

a) $\log_2 32 = 5$ b) $\log_a Q = 8$ c) $x = \log_t M$

Solution

a) $\log_2 32 = 5 \rightarrow 2^5 = 32$

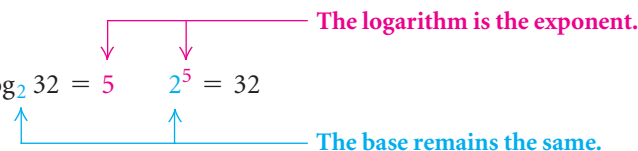

b) $\log_a Q = 8 \rightarrow a^8 = Q$

c) $x = \log_t M \rightarrow t^x = M$

➔ Now Try Exercise 45.

► Finding Logarithms on a Calculator

Before calculators became so widely available, base-10 logarithms, or **common logarithms**, were used extensively to simplify complicated calculations. In fact, that is why logarithms were invented. The abbreviation **log**, with no base written, is used to represent common logarithms, or base-10 logarithms. Thus,

log x means $\log_{10} x$.

For example, $\log 29$ means $\log_{10} 29$. Let's compare $\log 29$ with $\log 10$ and $\log 100$:

$$\left. \begin{array}{l} \log 10 = \log_{10} 10 = 1 \\ \log 29 = ? \\ \log 100 = \log_{10} 100 = 2 \end{array} \right\} \begin{array}{l} \text{Since 29 is between 10 and 100, it seems} \\ \text{reasonable that } \log 29 \text{ is between 1 and 2.} \end{array}$$

On a calculator, the key for common logarithms is generally marked **LOG**. Using that key, we find that

$$\log 29 \approx 1.462397998 \approx 1.4624$$

rounded to four decimal places. Since $1 < 1.4624 < 2$, our answer seems reasonable. This also tells us that $10^{1.4624} \approx 29$.

EXAMPLE 5 Find each of the following common logarithms on a calculator. If you are using a graphing calculator, set the calculator in REAL mode. Round to four decimal places.

- a) $\log 645,778$ b) $\log 0.0000239$ c) $\log(-3)$

Solution

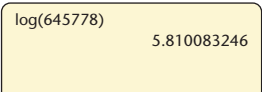
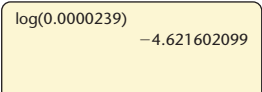
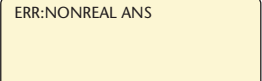
FUNCTION VALUE	READOUT	ROUNDED
a) $\log 645,778$		5.8101
b) $\log 0.0000239$		-4.6216
c) $\log(-3)$		Does not exist

Since 5.810083246 is the power to which we raise 10 to get 645,778, we can check part (a) by finding $10^{5.810083246}$. We can check part (b) in a similar manner. In part (c), $\log(-3)$ does not exist as a real number because there is no real-number power to which we can raise 10 to get -3 . The number 10 raised to any real-number power is positive. The common logarithm of a negative number does not exist as a real number. Recall that logarithmic functions are inverses of exponential functions, and since the range of an exponential function is $(0, \infty)$, the domain of $f(x) = \log_a x$ is $(0, \infty)$.

➔ **Now Try Exercises 57 and 61.**

*If the graphing calculator is set in $a + bi$ mode, the readout is $.4771212547 + 1.364376354i$.

► Natural Logarithms

Logarithms, base e , are called **natural logarithms**. The abbreviation “ln” is generally used for natural logarithms. Thus,

ln x means $\log_e x$.

For example, $\ln 53$ means $\log_e 53$. On a calculator, the key for natural logarithms is generally marked **LN**. Using that key, we find that



$$\begin{aligned}\ln 53 &\approx 3.970291914 \\ &\approx 3.9703\end{aligned}$$

rounded to four decimal places. This also tells us that $e^{3.9703} \approx 53$.

EXAMPLE 6 Find each of the following natural logarithms on a calculator. If you are using a graphing calculator, set the calculator in REAL mode. Round to four decimal places.

- a) $\ln 645,778$ b) $\ln 0.0000239$ c) $\ln(-5)$
d) $\ln e$ e) $\ln 1$

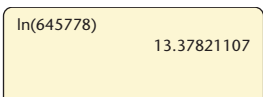
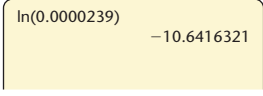
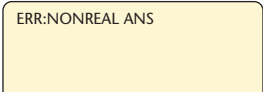
Solution

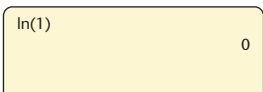
FUNCTION VALUE	READOUT	ROUNDED
a) $\ln 645,778$		13.3782
b) $\ln 0.0000239$		-10.6416
c) $\ln(-5)$	 *	Does not exist
d) $\ln e$		1
e) $\ln 1$		0

Since 13.37821107 is the power to which we raise e to get 645,778, we can check part (a) by finding $e^{13.37821107}$. We can check parts (b), (d), and (e) in a similar manner. In parts (d) and (e), note that $\ln e = \log_e e = 1$ and $\ln 1 = \log_e 1 = 0$.

 **Now Try Exercises 65 and 67.**

$\ln 1 = 0$ and $\ln e = 1$, for the logarithmic base e .

*If the graphing calculator is set in $a + bi$ mode, the readout is $1.609437912 + 3.141592654i$.

► Changing Logarithmic Bases

Most calculators give the values of both common logarithms and natural logarithms. To find a logarithm with a base other than 10 or e , we can use the following conversion formula.

The Change-of-Base Formula

For any logarithmic bases a and b , and any positive number M ,

$$\log_b M = \frac{\log_a M}{\log_a b}$$

We will prove this result in the next section.

EXAMPLE 7 Find $\log_5 8$ using common logarithms.

Solution First, we let $a = 10$, $b = 5$, and $M = 8$. Then we substitute into the change-of-base formula:

$$\log_5 8 = \frac{\log_{10} 8}{\log_{10} 5} \quad \text{Substituting}$$

$$\approx 1.2920. \quad \text{Using a calculator}$$

Since $\log_5 8$ is the power to which we raise 5 to get 8, we would expect this power to be greater than 1 ($5^1 = 5$) and less than 2 ($5^2 = 25$), so the result is reasonable.

➔ Now Try Exercise 69.

We can also use base e for a conversion.

EXAMPLE 8 Find $\log_5 8$ using natural logarithms.

Solution Substituting e for a , 5 for b , and 8 for M , we have

$$\begin{aligned} \log_5 8 &= \frac{\log_e 8}{\log_e 5} \\ &= \frac{\ln 8}{\ln 5} \approx 1.2920. \end{aligned}$$

Note that we get the same value using base e for the conversion that we did using base 10 in Example 7.

➔ Now Try Exercise 75.

TECHNOLOGY CONNECTION

To graph $y = \log_5 x$ in Example 9 with a graphing calculator, we must first change the base to 10 or e . Here we change from base 5 to base e :

$$y = \log_5 x = \frac{\ln x}{\ln 5}.$$

The graph is shown below.

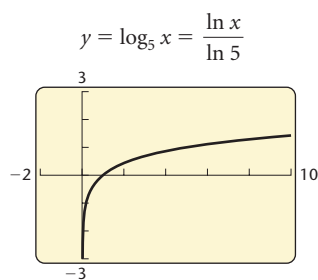

Some graphing calculators can graph inverses without the need to first find an equation of the inverse. If we begin with $y_1 = 5^x$, the graphs of both y_1 and its inverse, $y_2 = \log_5 x$, will be drawn as shown below.

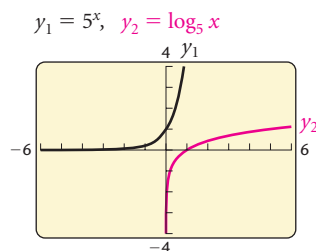

Graphs of Logarithmic Functions

Let's now consider graphs of logarithmic functions.

EXAMPLE 9 Graph: $y = f(x) = \log_5 x$.

Solution The equation $y = \log_5 x$ is equivalent to $x = 5^y$. We can find ordered pairs that are solutions by choosing values for y and computing the corresponding x -values. We then plot points, remembering that x is still the first coordinate.

For $y = 0$, $x = 5^0 = 1$.

For $y = 1$, $x = 5^1 = 5$.

For $y = 2$, $x = 5^2 = 25$.

For $y = 3$, $x = 5^3 = 125$.

For $y = -1$, $x = 5^{-1} = \frac{1}{5}$.

For $y = -2$, $x = 5^{-2} = \frac{1}{25}$.

x , or 5^y	y
1	0
5	1
25	2
125	3
$\frac{1}{5}$	-1
$\frac{1}{25}$	-2

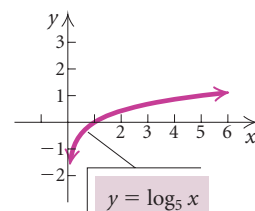

↑ (1) Select y .
 ↑ (2) Compute x .

➔ Now Try Exercises 5 and 79.

EXAMPLE 10 Graph: $g(x) = \ln x$.

Solution To graph $y = g(x) = \ln x$, we select values for x and use the **LN** key on a calculator to find the corresponding values of $\ln x$. We then plot points and draw the curve.

x	$g(x)$
	$g(x) = \ln x$
0.5	-0.7
1	0
2	0.7
3	1.1
4	1.4
5	1.6

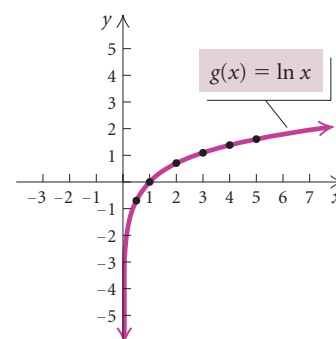

We could also write $g(x) = \ln x$, or $y = \ln x$, as $x = e^y$, select values for y , and use a calculator to find the corresponding values of x .

➔ Now Try Exercise 7.

Recall that the graph of $f(x) = \log_a x$, for any base a , has the x -intercept $(1, 0)$. The domain is the set of positive real numbers, and the range is the set of all real numbers. The y -axis is the vertical asymptote.

EXAMPLE 11 Graph each of the following. Before doing so, describe how each graph can be obtained from the graph of $y = \ln x$. Give the domain and the vertical asymptote of each function.

a) $f(x) = \ln(x + 3)$

b) $f(x) = 3 - \frac{1}{2} \ln x$

c) $f(x) = |\ln(x - 1)|$

Solution

- a) The graph of $f(x) = \ln(x + 3)$ is a shift of the graph of $y = \ln x$ left 3 units. The domain is the set of all real numbers greater than -3 , $(-3, \infty)$. The line $x = -3$ is the vertical asymptote.

x	$f(x)$
-2.9	-2.303
-2	0
0	1.099
2	1.609
4	1.946

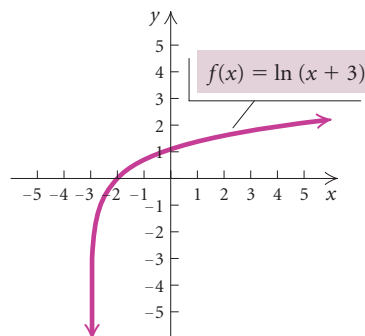

- b) The graph of $f(x) = 3 - \frac{1}{2} \ln x$ is a vertical shrinking of the graph of $y = \ln x$, followed by a reflection across the x -axis, and then a translation up 3 units. The domain is the set of all positive real numbers, $(0, \infty)$. The y -axis is the vertical asymptote.

x	$f(x)$
0.1	4.151
1	3
3	2.451
6	2.104
9	1.901

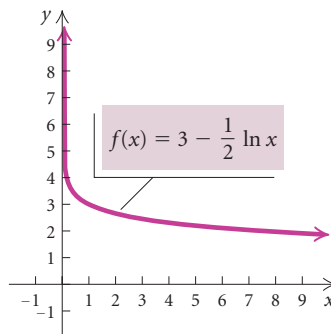

- c) The graph of $f(x) = |\ln(x - 1)|$ is a translation of the graph of $y = \ln x$ right 1 unit. Then the absolute value has the effect of reflecting negative outputs across the x -axis. The domain is the set of all real numbers greater than 1, $(1, \infty)$. The line $x = 1$ is the vertical asymptote.

x	$f(x)$
1.1	2.303
2	0
4	1.099
6	1.609
8	1.946

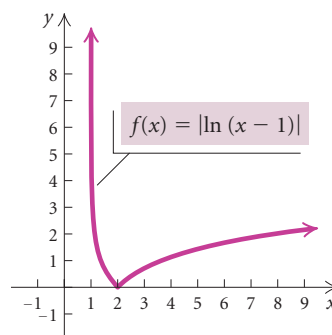

➔ Now Try Exercise 89.

► Applications

EXAMPLE 12 Walking Speed. In a study by psychologists Bornstein and Bornstein, it was found that the average walking speed w , in feet per second, of a person living in a city of population P , in thousands, is given by the function

$$w(P) = 0.37 \ln P + 0.05$$

(Source: *International Journal of Psychology*).

- The population of Savannah, Georgia, is 132,410. Find the average walking speed of people living in Savannah.
- The population of Philadelphia, Pennsylvania, is 1,540,351. Find the average walking speed of people living in Philadelphia.

Solution

- a) Since P is in thousands and $132,410 = 132.410$ thousand, we substitute 132.410 for P :

$$\begin{aligned} w(132.410) &= 0.37 \ln 132.410 + 0.05 && \text{Substituting} \\ &\approx 1.9. && \text{Finding the natural} \\ &&& \text{logarithm and simplifying} \end{aligned}$$

The average walking speed of people living in Savannah is about 1.9 ft/sec.

- b) We substitute 1540.351 for P :

$$\begin{aligned} w(1540.351) &= 0.37 \ln 1540.351 + 0.05 && \text{Substituting} \\ &\approx 2.8. \end{aligned}$$

The average walking speed of people living in Philadelphia is about 2.8 ft/sec.

➔ Now Try Exercise 95(d).

EXAMPLE 13 *Earthquake Magnitude.* The magnitude R , measured on the Richter scale, of an earthquake of intensity I is defined as

$$R = \log \frac{I}{I_0},$$

where I_0 is a minimum intensity used for comparison. We can think of I_0 as a threshold intensity that is the weakest earthquake that can be recorded on a seismograph. If one earthquake is 10 times as intense as another, its magnitude on the Richter scale is 1 greater than that of the other. If one earthquake is 100 times as intense as another, its magnitude on the Richter scale is 2 higher, and so on. Thus an earthquake whose magnitude is 7 on the Richter scale is 10 times as intense as an earthquake whose magnitude is 6. Earthquake intensities can be interpreted as multiples of the minimum intensity I_0 .

The undersea earthquake off the west coast of northern Sumatra on December 26, 2004, had an intensity of $10^{9.3} \cdot I_0$ (Sources: U.S. Geological Survey; National Earthquake Information Center). It caused devastating tsunamis that hit twelve Indian Ocean countries. What was its magnitude on the Richter scale?

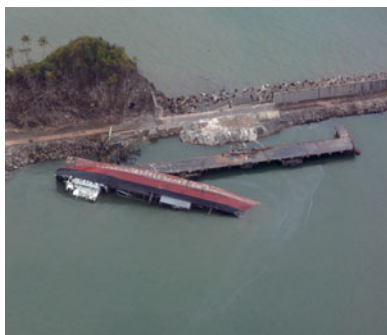

Solution We substitute into the formula:

$$R = \log \frac{I}{I_0} = \log \frac{10^{9.3} \cdot I_0}{I_0} = \log 10^{9.3} = 9.3.$$

The magnitude of the earthquake was 9.3 on the Richter scale.

➔ Now Try Exercise 97(a).

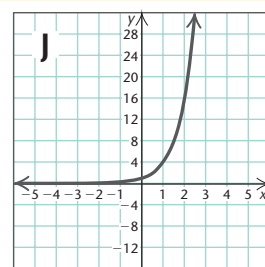
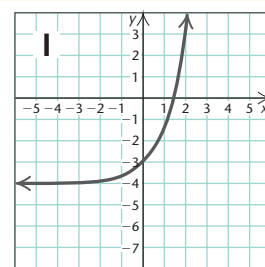
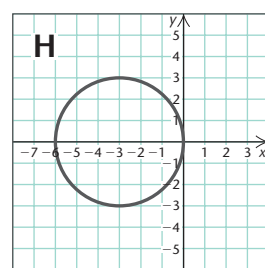
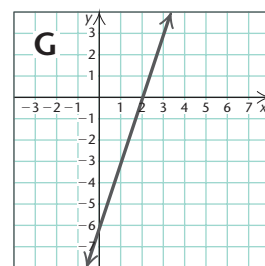
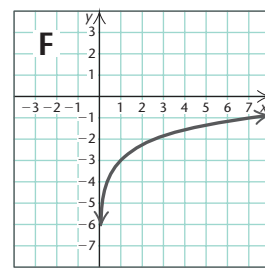
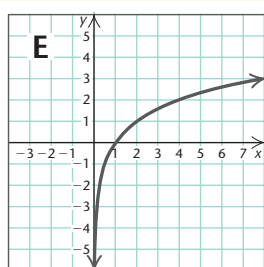
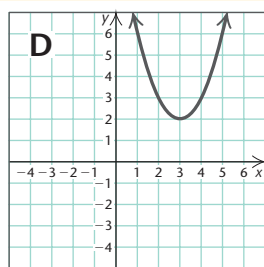
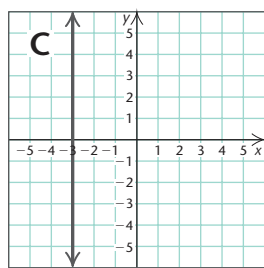
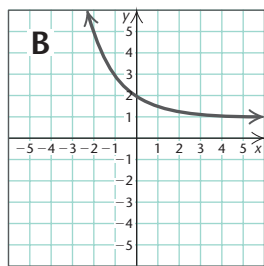
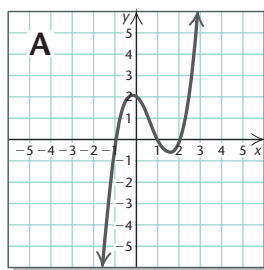

Visualizing the Graph

Match the equation or function with its graph.

- $f(x) = 4^x$
- $f(x) = \ln x - 3$
- $(x + 3)^2 + y^2 = 9$
- $f(x) = 2^{-x} + 1$
- $f(x) = \log_2 x$
- $f(x) = x^3 - 2x^2 - x + 2$
- $x = -3$
- $f(x) = e^x - 4$
- $f(x) = (x - 3)^2 + 2$
- $3x = 6 + y$

Answers on page A-32

5.3

Exercise Set

Graph.

- | | |
|-------------------------------------|-------------------------------------|
| 1. $x = 3^y$ | 2. $x = 4^y$ |
| 3. $x = \left(\frac{1}{2}\right)^y$ | 4. $x = \left(\frac{4}{3}\right)^y$ |
| 5. $y = \log_3 x$ | 6. $y = \log_4 x$ |
| 7. $f(x) = \log x$ | 8. $f(x) = \ln x$ |

Find each of the following. Do not use a calculator.

- | | |
|--------------------------|-----------------------|
| 9. $\log_2 16$ | 10. $\log_3 9$ |
| 11. $\log_5 125$ | 12. $\log_2 64$ |
| 13. $\log 0.001$ | 14. $\log 100$ |
| 15. $\log_2 \frac{1}{4}$ | 16. $\log_8 2$ |
| 17. $\ln 1$ | 18. $\ln e$ |
| 19. $\log 10$ | 20. $\log 1$ |
| 21. $\log_5 5^4$ | 22. $\log \sqrt{10}$ |
| 23. $\log_3 \sqrt[4]{3}$ | 24. $\log 10^{8/5}$ |
| 25. $\log 10^{-7}$ | 26. $\log_5 1$ |
| 27. $\log_{49} 7$ | 28. $\log_3 3^{-2}$ |
| 29. $\ln e^{3/4}$ | 30. $\log_2 \sqrt{2}$ |
| 31. $\log_4 1$ | 32. $\ln e^{-5}$ |
| 33. $\ln \sqrt{e}$ | 34. $\log_{64} 4$ |

Convert to a logarithmic equation.

- | | |
|--------------------|------------------------------|
| 35. $10^3 = 1000$ | 36. $5^{-3} = \frac{1}{125}$ |
| 37. $8^{1/3} = 2$ | 38. $10^{0.3010} = 2$ |
| 39. $e^3 = t$ | 40. $Q^t = x$ |
| 41. $e^2 = 7.3891$ | 42. $e^{-1} = 0.3679$ |
| 43. $p^k = 3$ | 44. $e^{-t} = 4000$ |

Convert to an exponential equation.

- | | |
|-----------------------|--------------------------|
| 45. $\log_5 5 = 1$ | 46. $t = \log_4 7$ |
| 47. $\log 0.01 = -2$ | 48. $\log 7 = 0.845$ |
| 49. $\ln 30 = 3.4012$ | 50. $\ln 0.38 = -0.9676$ |
| 51. $\log_a M = -x$ | 52. $\log_t Q = k$ |
| 53. $\log_a T^3 = x$ | 54. $\ln W^5 = t$ |

Find each of the following using a calculator. Round to four decimal places.

- | | |
|------------------|-------------------|
| 55. $\log 3$ | 56. $\log 8$ |
| 57. $\log 532$ | 58. $\log 93,100$ |
| 59. $\log 0.57$ | 60. $\log 0.082$ |
| 61. $\log(-2)$ | 62. $\ln 50$ |
| 63. $\ln 2$ | 64. $\ln(-4)$ |
| 65. $\ln 809.3$ | 66. $\ln 0.00037$ |
| 67. $\ln(-1.32)$ | 68. $\ln 0$ |

Find the logarithm using common logarithms and the change-of-base formula. Round to four decimal places.

- | | |
|----------------------|-----------------------|
| 69. $\log_4 100$ | 70. $\log_3 20$ |
| 71. $\log_{100} 0.3$ | 72. $\log_\pi 100$ |
| 73. $\log_{200} 50$ | 74. $\log_{5.3} 1700$ |

Find the logarithm using natural logarithms and the change-of-base formula. Round to four decimal places.

- | | |
|---------------------|------------------|
| 75. $\log_3 12$ | 76. $\log_4 25$ |
| 77. $\log_{100} 15$ | 78. $\log_9 100$ |

Graph the function and its inverse using the same set of axes. Use any method.

- | |
|--|
| 79. $f(x) = 3^x, f^{-1}(x) = \log_3 x$ |
| 80. $f(x) = \log_4 x, f^{-1}(x) = 4^x$ |
| 81. $f(x) = \log x, f^{-1}(x) = 10^x$ |
| 82. $f(x) = e^x, f^{-1}(x) = \ln x$ |

For each of the following functions, briefly describe how the graph can be obtained from the graph of a basic logarithmic function. Then graph the function. Give the domain and the vertical asymptote of each function.

- | | |
|----------------------------|--------------------------------|
| 83. $f(x) = \log_2(x + 3)$ | 84. $f(x) = \log_3(x - 2)$ |
| 85. $y = \log_3 x - 1$ | 86. $y = 3 + \log_2 x$ |
| 87. $f(x) = 4 \ln x$ | 88. $f(x) = \frac{1}{2} \ln x$ |
| 89. $y = 2 - \ln x$ | 90. $y = \ln(x + 1)$ |

91. $f(x) = \frac{1}{2} \log(x - 1) - 2$

92. $f(x) = 5 - 2 \log(x + 1)$

Graph the piecewise function.

93. $g(x) = \begin{cases} 5, & \text{for } x \leq 0, \\ \log x + 1, & \text{for } x > 0 \end{cases}$

94. $f(x) = \begin{cases} 1 - x, & \text{for } x \leq -1, \\ \ln(x + 1), & \text{for } x > -1 \end{cases}$

95. **Walking Speed.** Refer to Example 12. Various cities and their populations are given below. Find the average walking speed in each city.

- Seattle, Washington: 598,541
- Los Angeles, California: 3,833,995
- Virginia Beach, Virginia: 433,746
- Houston, Texas: 2,242,193
- Memphis, Tennessee: 669,651
- Tampa, Florida: 340,882
- Indianapolis, Indiana: 798,382
- Anchorage, Alaska: 279,243

96. **Forgetting.** Students in an accounting class took a final exam and then took equivalent forms of the exam at monthly intervals thereafter. The average score $S(t)$, as a percent, after t months was found to be given by the function

$$S(t) = 78 - 15 \log(t + 1), \quad t \geq 0.$$

- What was the average score when the students initially took the test, $t = 0$?
- What was the average score after 4 months? after 24 months?

97. **Earthquake Magnitude.** Refer to Example 13. Various locations of earthquakes and their intensities are given below. What was the magnitude on the Richter scale?

- San Francisco, California, 1906: $10^{7.7} \cdot I_0$
- Chile, 1960: $10^{9.5} \cdot I_0$
- Iran, 2003: $10^{6.6} \cdot I_0$
- Turkey, 1999: $10^{7.4} \cdot I_0$
- Peru, 2007: $10^{8.0} \cdot I_0$
- China, 2008: $10^{7.9} \cdot I_0$
- Indonesia, 2004: $10^{9.1} \cdot I_0$
- Japan, 1995: $10^{6.9} \cdot I_0$

98. **pH of Substances in Chemistry.** In chemistry, the pH of a substance is defined as

$$\text{pH} = -\log[H^+],$$

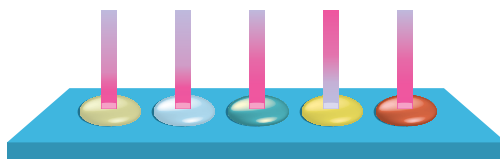
where H^+ is the hydrogen ion concentration, in moles per liter. Find the pH of each substance.

Litmus paper is used to test pH.

SUBSTANCE	HYDROGEN ION CONCENTRATION
a) Pineapple juice	1.6×10^{-4}
b) Hair conditioner	0.0013
c) Mouthwash	6.3×10^{-7}
d) Eggs	1.6×10^{-8}
e) Tomatoes	6.3×10^{-5}

99. Find the hydrogen ion concentration of each substance, given the pH. (See Exercise 98.) Express the answer in scientific notation.

SUBSTANCE	pH
a) Tap water	7
b) Rainwater	5.4
c) Orange juice	3.2
d) Wine	4.8

100. **Advertising.** A model for advertising response is given by the function

$$N(a) = 1000 + 200 \ln a, \quad a \geq 1,$$

where $N(a)$ is the number of units sold when a is the amount spent on advertising, in thousands of dollars.

- a) How many units were sold after spending \$1000 ($a = 1$) on advertising?
 b) How many units were sold after spending \$5000?
 101. **Loudness of Sound.** The **loudness** L , in bels (after Alexander Graham Bell), of a sound of intensity I is defined to be

$$L = \log \frac{I}{I_0},$$

where I_0 is the minimum intensity detectable by the human ear (such as the tick of a watch at 20 ft under quiet conditions). If a sound is 10 times as intense as another, its loudness is 1 bel greater than that of the other. If a sound is 100 times as intense as another, its loudness is 2 bels greater, and so on. The bel is a large unit, so a subunit, the **decibel**, is generally used. For L , in decibels, the formula is

$$L = 10 \log \frac{I}{I_0}.$$



Find the loudness, in decibels, of each sound with the given intensity.

SOUND	INTENSITY
a) Jet engine at 100 ft	$10^{14} \cdot I_0$
b) Loud rock concert	$10^{11.5} \cdot I_0$
c) Train whistle at 500 ft	$10^9 \cdot I_0$
d) Normal conversation	$10^{6.5} \cdot I_0$
e) Trombone	$10^{10} \cdot I_0$
f) Loudest sound possible	$10^{19.4} \cdot I_0$

Skill Maintenance

Find the slope and the y -intercept of the line.

102. $3x - 10y = 14$

103. $y = 6$

104. $x = -4$

Use synthetic division to find the function values.

105. $g(x) = x^3 - 6x^2 + 3x + 10$; find $g(-5)$

106. $f(x) = x^4 - 2x^3 + x - 6$; find $f(-1)$

Find a polynomial function of degree 3 with the given numbers as zeros. Answers may vary.

107. $\sqrt{7}, -\sqrt{7}, 0$

108. $4i, -4i, 1$

Synthesis

Simplify.

109. $\frac{\log_5 8}{\log_5 2}$

110. $\frac{\log_3 64}{\log_3 16}$

Find the domain of the function.

111. $f(x) = \log_5 x^3$

112. $f(x) = \log_4 x^2$

113. $f(x) = \ln |x|$

114. $f(x) = \log(3x - 4)$

Solve.

115. $\log_2(2x + 5) < 0$

116. $\log_2(x - 3) \geq 4$

In Exercises 117–120, match the equation with one of the figures (a)–(d), which follow.

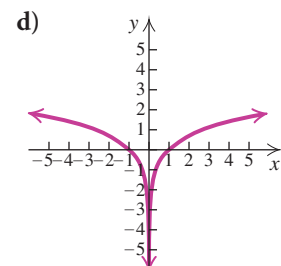
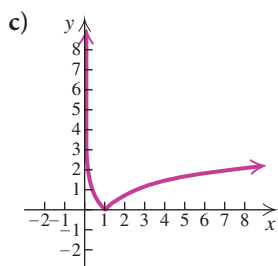
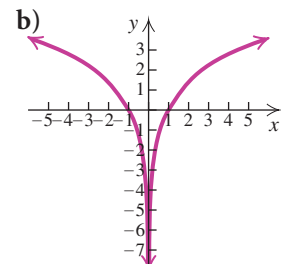
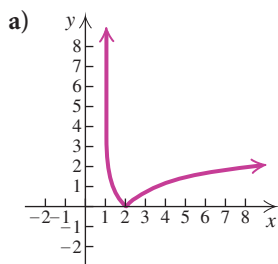

117. $f(x) = \ln |x|$

118. $f(x) = |\ln x|$

119. $f(x) = \ln x^2$

120. $g(x) = |\ln(x - 1)|$

Mid-Chapter Mixed Review

Determine whether the statement is true or false.

- The domain of all logarithmic functions is $[1, \infty)$. [5.3]
- The range of a one-to-one function f is the domain of its inverse f^{-1} . [5.1]
- The y -intercept of $f(x) = e^{-x}$ is $(0, -1)$. [5.2]

For each function, determine whether it is one-to-one, and if the function is one-to-one, find a formula for its inverse. [5.1]

- $f(x) = -\frac{2}{x}$
- $f(x) = 3 + x^2$
- $f(x) = \frac{5}{x-2}$
- Given the function $f(x) = \sqrt{x-5}$, use composition of functions to show that $f^{-1}(x) = x^2 + 5$. [5.1]
- Given the one-to-one function $f(x) = x^3 + 2$, find the inverse, give the domain and the range of f and f^{-1} , and graph both f and f^{-1} on the same set of axes. [5.1]

Match the function with one of the graphs (a)–(h), which follow. [5.2], [5.3]

- $y = \log_2 x$
- $f(x) = 2^x + 2$
- $f(x) = e^{x-1}$
- $f(x) = \ln x - 2$
- $f(x) = \ln(x-2)$
- $y = 2^{-x}$
- $f(x) = |\log x|$
- $f(x) = e^x + 1$

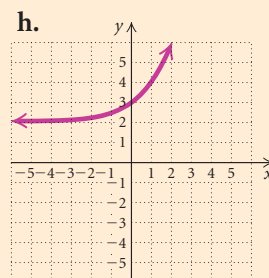
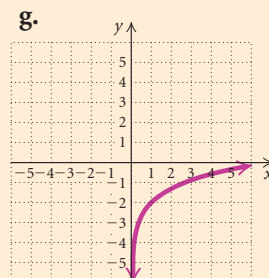
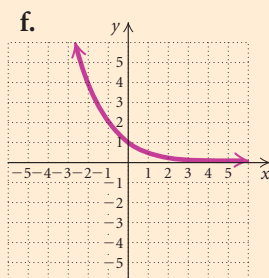
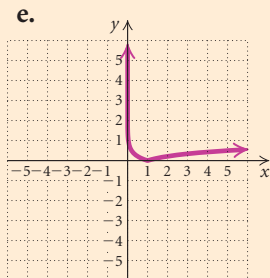
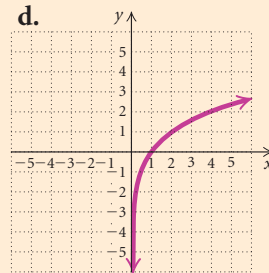
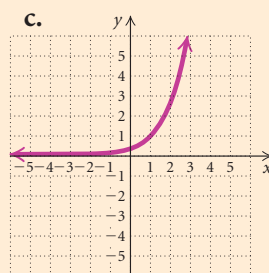
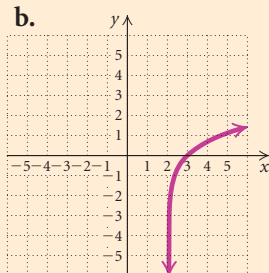
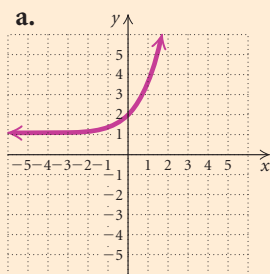

- Suppose that \$3200 is invested at $4\frac{1}{2}\%$ interest, compounded quarterly. Find the amount of money in the account in 6 years. [5.2]

Find each of the following without a calculator. [5.3]

- $\log_4 1$
- $\ln e^{-4/5}$
- $\log 0.01$
- $\ln e^2$
- $\ln 1$
- $\log_2 \frac{1}{16}$
- $\log 1$
- $\log_3 27$
- $\log \sqrt[4]{10}$
- $\ln e$

28. Convert $e^{-6} = 0.0025$ to a logarithmic equation. [5.3]

29. Convert $\log T = r$ to an exponential equation. [5.3]

Find the logarithm using the change-of-base formula. [5.3]

30. $\log_3 20$

31. $\log_\pi 10$

Collaborative Discussion and Writing

32. Explain why an even function f does not have an inverse f^{-1} that is a function. [5.1]

33. Suppose that \$10,000 is invested for 8 years at 6.4% interest, compounded annually. In what year will the most interest be earned? Why? [5.2]

34. Describe the differences between the graphs of $f(x) = x^3$ and $g(x) = 3^x$. [5.2]

35. If $\log b < 0$, what can you say about b ? [5.3]

Properties of Logarithmic Functions

5.4

- ▶ Convert from logarithms of products, powers, and quotients to expressions in terms of individual logarithms, and conversely.
- ▶ Simplify expressions of the type $\log_a a^x$ and $a^{\log_a x}$.

We now establish some properties of logarithmic functions. These properties are based on the corresponding rules for exponents.

▶ Logarithms of Products

The first property of logarithms corresponds to the product rule for exponents: $a^m \cdot a^n = a^{m+n}$.

The Product Rule

For any positive numbers M and N and any logarithmic base a ,

$$\log_a MN = \log_a M + \log_a N.$$

(The logarithm of a product is the sum of the logarithms of the factors.)

EXAMPLE 1 Express as a sum of logarithms: $\log_3 (9 \cdot 27)$.

Solution We have

$$\log_3 (9 \cdot 27) = \log_3 9 + \log_3 27. \quad \text{Using the product rule}$$

As a check, note that

$$\log_3 (9 \cdot 27) = \log_3 243 = 5 \quad 3^5 = 243$$

$$\text{and} \quad \log_3 9 + \log_3 27 = 2 + 3 = 5. \quad 3^2 = 9; 3^3 = 27$$

 **Now Try Exercise 1.**

EXAMPLE 2 Express as a single logarithm: $\log_2 p^3 + \log_2 q$.

Solution We have

$$\log_2 p^3 + \log_2 q = \log_2 (p^3 q).$$

 **Now Try Exercise 35.**

A Proof of the Product Rule Let $\log_a M = x$ and $\log_a N = y$. Converting to exponential equations, we have $a^x = M$ and $a^y = N$. Then

$$MN = a^x \cdot a^y = a^{x+y}.$$

Converting back to a logarithmic equation, we get

$$\log_a MN = x + y.$$

Remembering what x and y represent, we know it follows that

$$\log_a MN = \log_a M + \log_a N.$$

► Logarithms of Powers

The second property of logarithms corresponds to the power rule for exponents: $(a^m)^n = a^{mn}$.

The Power Rule

For any positive number M , any logarithmic base a , and any real number p ,

$$\log_a M^p = p \log_a M.$$

(The logarithm of a power of M is the exponent times the logarithm of M .)

EXAMPLE 3 Express each of the following as a product.

a) $\log_a 11^{-3}$ b) $\log_a \sqrt[4]{7}$ c) $\ln x^6$

Solution

a) $\log_a 11^{-3} = -3 \log_a 11$ **Using the power rule**

b) $\log_a \sqrt[4]{7} = \log_a 7^{1/4}$ **Writing exponential notation**

$= \frac{1}{4} \log_a 7$ **Using the power rule**

c) $\ln x^6 = 6 \ln x$ **Using the power rule**

 **Now Try Exercises 13 and 15.**

RATIONAL EXPONENTS

REVIEW SECTION R.7

A Proof of the Power Rule Let $x = \log_a M$. The equivalent exponential equation is $a^x = M$. Raising both sides to the power p , we obtain

$$(a^x)^p = M^p, \quad \text{or} \quad a^{xp} = M^p.$$

Converting back to a logarithmic equation, we get

$$\log_a M^p = xp.$$

But $x = \log_a M$, so substituting gives us

$$\log_a M^p = (\log_a M)p = p \log_a M. \quad \leftarrow$$

► Logarithms of Quotients

The third property of logarithms corresponds to the quotient rule for exponents: $a^m/a^n = a^{m-n}$.

The Quotient Rule

For any positive numbers M and N , and any logarithmic base a ,

$$\log_a \frac{M}{N} = \log_a M - \log_a N.$$

(The logarithm of a quotient is the logarithm of the numerator minus the logarithm of the denominator.)

EXAMPLE 4 Express as a difference of logarithms: $\log_t \frac{8}{w}$.

Solution We have

$$\log_t \frac{8}{w} = \log_t 8 - \log_t w. \quad \text{Using the quotient rule}$$

➔ Now Try Exercise 17.

EXAMPLE 5 Express as a single logarithm: $\log_b 64 - \log_b 16$.

Solution We have

$$\log_b 64 - \log_b 16 = \log_b \frac{64}{16} = \log_b 4.$$

➔ Now Try Exercise 37.

A Proof of the Quotient Rule The proof follows from both the product rule and the power rule:

$$\begin{aligned} \log_a \frac{M}{N} &= \log_a MN^{-1} \\ &= \log_a M + \log_a N^{-1} && \text{Using the product rule} \\ &= \log_a M + (-1)\log_a N && \text{Using the power rule} \\ &= \log_a M - \log_a N. \end{aligned} \quad \leftarrow$$

Common Errors

$$\log_a MN \neq (\log_a M)(\log_a N)$$

The logarithm of a product is *not* the product of the logarithms.

$$\log_a (M + N) \neq \log_a M + \log_a N$$

The logarithm of a sum is *not* the sum of the logarithms.

$$\log_a \frac{M}{N} \neq \frac{\log_a M}{\log_a N}$$

The logarithm of a quotient is *not* the quotient of the logarithms.

$$(\log_a M)^p \neq p \log_a M$$

The power of a logarithm is *not* the exponent times the logarithm.

► Applying the Properties

EXAMPLE 6 Express each of the following in terms of sums and differences of logarithms.

a) $\log_a \frac{x^2 y^5}{z^4}$

b) $\log_a \sqrt[3]{\frac{a^2 b}{c^5}}$

c) $\log_b \frac{ay^5}{m^3 n^4}$

Solution

a) $\log_a \frac{x^2 y^5}{z^4} = \log_a (x^2 y^5) - \log_a z^4$

Using the quotient rule

$$= \log_a x^2 + \log_a y^5 - \log_a z^4$$

Using the product rule

$$= 2 \log_a x + 5 \log_a y - 4 \log_a z$$

Using the power rule

b) $\log_a \sqrt[3]{\frac{a^2 b}{c^5}} = \log_a \left(\frac{a^2 b}{c^5} \right)^{1/3}$

Writing exponential notation

$$= \frac{1}{3} \log_a \frac{a^2 b}{c^5}$$

Using the power rule

$$= \frac{1}{3} (\log_a a^2 b - \log_a c^5)$$

Using the quotient rule.
The parentheses are necessary.

$$= \frac{1}{3} (2 \log_a a + \log_a b - 5 \log_a c)$$

Using the product
and the power rule

$$= \frac{1}{3} (2 + \log_a b - 5 \log_a c)$$

$\log_a a = 1$

$$= \frac{2}{3} + \frac{1}{3} \log_a b - \frac{5}{3} \log_a c$$

Multiplying to
remove parentheses

c) $\log_b \frac{ay^5}{m^3 n^4} = \log_b ay^5 - \log_b m^3 n^4$

Using the
quotient rule

$$= (\log_b a + \log_b y^5) - (\log_b m^3 + \log_b n^4)$$

Using the
product rule

$$= \log_b a + \log_b y^5 - \log_b m^3 - \log_b n^4$$

Removing
parentheses

$$= \log_b a + 5 \log_b y - 3 \log_b m - 4 \log_b n$$

Using the
power rule

EXAMPLE 7 Express as a single logarithm:

$$5 \log_b x - \log_b y + \frac{1}{4} \log_b z.$$

Solution We have

$$\begin{aligned} 5 \log_b x - \log_b y + \frac{1}{4} \log_b z &= \log_b x^5 - \log_b y + \log_b z^{1/4} && \text{Using the power rule} \\ &= \log_b \frac{x^5}{y} + \log_b z^{1/4} && \text{Using the quotient rule} \\ &= \log_b \frac{x^5 z^{1/4}}{y}, \text{ or } \log_b \frac{x^5 \sqrt[4]{z}}{y}. && \text{Using the product rule} \end{aligned}$$

 **Now Try Exercise 41.**

EXAMPLE 8 Express as a single logarithm:

$$\ln(3x + 1) - \ln(3x^2 - 5x - 2).$$

Solution We have

$$\begin{aligned} \ln(3x + 1) - \ln(3x^2 - 5x - 2) &= \ln \frac{3x + 1}{3x^2 - 5x - 2} && \text{Using the quotient rule} \\ &= \ln \frac{3x + 1}{(3x + 1)(x - 2)} && \text{Factoring} \\ &= \ln \frac{1}{x - 2}. && \text{Simplifying} \end{aligned}$$

 **Now Try Exercise 45.**

EXAMPLE 9 Given that $\log_a 2 \approx 0.301$ and $\log_a 3 \approx 0.477$, find each of the following, if possible.

- | | | |
|-------------------------|-------------------------|--------------------------------|
| a) $\log_a 6$ | b) $\log_a \frac{2}{3}$ | c) $\log_a 81$ |
| d) $\log_a \frac{1}{4}$ | e) $\log_a 5$ | f) $\frac{\log_a 3}{\log_a 2}$ |

Solution

$$\begin{aligned} \text{a) } \log_a 6 &= \log_a (2 \cdot 3) = \log_a 2 + \log_a 3 && \text{Using the product rule} \\ &\approx 0.301 + 0.477 \\ &\approx 0.778 \end{aligned}$$

$$\begin{aligned} \text{b) } \log_a \frac{2}{3} &= \log_a 2 - \log_a 3 && \text{Using the quotient rule} \\ &\approx 0.301 - 0.477 \approx -0.176 \end{aligned}$$

$$\begin{aligned} \text{c) } \log_a 81 &= \log_a 3^4 = 4 \log_a 3 && \text{Using the power rule} \\ &\approx 4(0.477) \approx 1.908 \end{aligned}$$

- d) $\log_a \frac{1}{4} = \log_a 1 - \log_a 4$ **Using the quotient rule**
 $= 0 - \log_a 2^2$ **$\log_a 1 = 0$**
 $= -2 \log_a 2$ **Using the power rule**
 $\approx -2(0.301) \approx -0.602$
- e) $\log_a 5$ cannot be found using these properties and the given information.
 $\log_a 5 \neq \log_a 2 + \log_a 3$ **$\log_a 2 + \log_a 3 = \log_a (2 \cdot 3) = \log_a 6$**
- f) $\frac{\log_a 3}{\log_a 2} \approx \frac{0.477}{0.301} \approx 1.585$ **We simply divide, not using any of the properties.**

 **Now Try Exercises 53 and 55.**

► Simplifying Expressions of the Type $\log_a a^x$ and $a^{\log_a x}$

We have two final properties of logarithms to consider. The first follows from the product rule: Since $\log_a a^x = x \log_a a = x \cdot 1 = x$, we have $\log_a a^x = x$. This property also follows from the definition of a logarithm: x is the power to which we raise a in order to get a^x .

The Logarithm of a Base to a Power

For any base a and any real number x ,

$$\log_a a^x = x.$$

(The logarithm, base a , of a to a power is the power.)

EXAMPLE 10 Simplify each of the following.

- a) $\log_a a^8$ b) $\ln e^{-t}$ c) $\log 10^{3k}$

Solution

- a) $\log_a a^8 = 8$ **8 is the power to which we raise a in order to get a^8 .**
b) $\ln e^{-t} = \log_e e^{-t} = -t$ **$\ln e^x = x$**
c) $\log 10^{3k} = \log_{10} 10^{3k} = 3k$

 **Now Try Exercises 65 and 73.**

Let $M = \log_a x$. Then $a^M = x$. Substituting $\log_a x$ for M , we obtain $a^{\log_a x} = x$. This also follows from the definition of a logarithm: $\log_a x$ is the power to which a is raised in order to get x .

A Base to a Logarithmic Power

For any base a and any positive real number x ,

$$a^{\log_a x} = x.$$

(The number a raised to the power $\log_a x$ is x .)

STUDY TIP

Immediately after each quiz or chapter test, write out step-by-step solutions to the questions you missed. Visit your instructor during office hours for help with problems that are still giving you trouble. When the week of the final examination arrives, you will be glad to have the excellent study guide these corrected tests provide.

EXAMPLE 11 Simplify each of the following.

a) $4^{\log_4 k}$

b) $e^{\ln 5}$

c) $10^{\log 7t}$

Solution

a) $4^{\log_4 k} = k$

b) $e^{\ln 5} = e^{\log_e 5} = 5$

c) $10^{\log 7t} = 10^{\log_{10} 7t} = 7t$

 Now Try Exercises 69 and 71.

A Proof of the Change-of-Base Formula We close this section by proving the change-of-base formula and summarizing the properties of logarithms considered thus far in this chapter. In Section 5.3, we used the change-of-base formula,

$$\log_b M = \frac{\log_a M}{\log_a b},$$

to make base conversions in order to find logarithmic values using a calculator. Let $x = \log_b M$. Then

$$b^x = M$$

Definition of logarithm

$$\log_a b^x = \log_a M$$

Taking the logarithm on both sides

$$x \log_a b = \log_a M$$

Using the power rule

$$x = \frac{\log_a M}{\log_a b},$$

Dividing by $\log_a b$

so

$$x = \log_b M = \frac{\log_a M}{\log_a b}.$$



CHANGE-OF-BASE FORMULA

REVIEW SECTION 5.3

Following is a summary of the properties of logarithms.

Summary of the Properties of Logarithms

The Product Rule: $\log_a MN = \log_a M + \log_a N$

The Power Rule: $\log_a M^p = p \log_a M$

The Quotient Rule: $\log_a \frac{M}{N} = \log_a M - \log_a N$

The Change-of-Base Formula: $\log_b M = \frac{\log_a M}{\log_a b}$

Other Properties: $\log_a a = 1, \quad \log_a 1 = 0,$
 $\log_a a^x = x, \quad a^{\log_a x} = x$

5.4

Exercise Set

Express as a sum of logarithms.

1. $\log_3 (81 \cdot 27)$
2. $\log_2 (8 \cdot 64)$
3. $\log_5 (5 \cdot 125)$
4. $\log_4 (64 \cdot 4)$
5. $\log_t 8Y$
6. $\log 0.2x$
7. $\ln xy$
8. $\ln ab$

Express as a product.

9. $\log_b t^3$
10. $\log_a x^4$
11. $\log y^8$
12. $\ln y^5$
13. $\log_c K^{-6}$
14. $\log_b Q^{-8}$
15. $\ln \sqrt[3]{4}$
16. $\ln \sqrt{a}$

Express as a difference of logarithms.

17. $\log_t \frac{M}{8}$
18. $\log_a \frac{76}{13}$
19. $\log \frac{x}{y}$
20. $\ln \frac{a}{b}$
21. $\ln \frac{r}{s}$
22. $\log_b \frac{3}{w}$

Express in terms of sums and differences of logarithms.

23. $\log_a 6xy^5z^4$
24. $\log_a x^3y^2z$
25. $\log_b \frac{p^2q^5}{m^4b^9}$
26. $\log_b \frac{x^2y}{b^3}$
27. $\ln \frac{2}{3x^3y}$
28. $\log \frac{5a}{4b^2}$
29. $\log \sqrt{r^3t}$
30. $\ln \sqrt[3]{5x^5}$
31. $\log_a \sqrt{\frac{x^6}{p^5q^8}}$
32. $\log_c \sqrt[3]{\frac{y^3z^2}{x^4}}$
33. $\log_a \sqrt[4]{\frac{m^8n^{12}}{a^3b^5}}$
34. $\log_a \sqrt{\frac{a^6b^8}{a^2b^5}}$

Express as a single logarithm and, if possible, simplify.

35. $\log_a 75 + \log_a 2$
36. $\log 0.01 + \log 1000$
37. $\log 10,000 - \log 100$
38. $\ln 54 - \ln 6$
39. $\frac{1}{2} \log n + 3 \log m$
40. $\frac{1}{2} \log a - \log 2$

41. $\frac{1}{2} \log_a x + 4 \log_a y - 3 \log_a x$
42. $\frac{2}{5} \log_a x - \frac{1}{3} \log_a y$
43. $\ln x^2 - 2 \ln \sqrt{x}$
44. $\ln 2x + 3(\ln x - \ln y)$
45. $\ln (x^2 - 4) - \ln (x + 2)$
46. $\log (x^3 - 8) - \log (x - 2)$
47. $\log (x^2 - 5x - 14) - \log (x^2 - 4)$
48. $\log_a \frac{a}{\sqrt{x}} - \log_a \sqrt{ax}$
49. $\ln x - 3[\ln (x - 5) + \ln (x + 5)]$
50. $\frac{2}{3}[\ln (x^2 - 9) - \ln (x + 3)] + \ln (x + y)$
51. $\frac{3}{2} \ln 4x^6 - \frac{4}{5} \ln 2y^{10}$
52. $120(\ln \sqrt[5]{x^3} + \ln \sqrt[3]{y^2} - \ln \sqrt[4]{16z^5})$

Given that $\log_a 2 \approx 0.301$, $\log_a 7 \approx 0.845$, and $\log_a 11 \approx 1.041$, find each of the following, if possible. Round the answer to the nearest thousandth.

53. $\log_a \frac{2}{11}$
54. $\log_a 14$
55. $\log_a 98$
56. $\log_a \frac{1}{7}$
57. $\frac{\log_a 2}{\log_a 7}$
58. $\log_a 9$

Given that $\log_b 2 \approx 0.693$, $\log_b 3 \approx 1.099$, and $\log_b 5 \approx 1.609$, find each of the following, if possible. Round the answer to the nearest thousandth.

59. $\log_b 125$
60. $\log_b \frac{5}{3}$
61. $\log_b \frac{1}{6}$
62. $\log_b 30$
63. $\log_b \frac{3}{b}$
64. $\log_b 15b$

Simplify.

65. $\log_p p^3$
66. $\log_t t^{2713}$
67. $\log_e e^{|x-4|}$
68. $\log_q q^{\sqrt{3}}$
69. $3^{\log_3 4x}$
70. $5^{\log_5 (4x-3)}$

71. $10^{\log w}$
 72. $e^{\ln x^3}$
 73. $\ln e^{8t}$
 74. $\log 10^{-k}$
 75. $\log_b \sqrt{b}$
 76. $\log_b \sqrt{b^3}$

Skill Maintenance

In each of Exercises 77–86, classify the function as linear, quadratic, cubic, quartic, rational, exponential, or logarithmic.

77. $f(x) = 5 - x^2 + x^4$
 78. $f(x) = 2^x$
 79. $f(x) = -\frac{3}{4}$
 80. $f(x) = 4^x - 8$
 81. $f(x) = -\frac{3}{x}$
 82. $f(x) = \log x + 6$
 83. $f(x) = -\frac{1}{3}x^3 - 4x^2 + 6x + 42$
 84. $f(x) = \frac{x^2 - 1}{x^2 + x - 6}$
 85. $f(x) = \frac{1}{2}x + 3$
 86. $f(x) = 2x^2 - 6x + 3$

Synthesis

Solve for x .

87. $5^{\log_5 8} = 2x$
 88. $\ln e^{3x-5} = -8$

Express as a single logarithm and, if possible, simplify.

89. $\log_a (x^2 + xy + y^2) + \log_a (x - y)$
 90. $\log_a (a^{10} - b^{10}) - \log_a (a + b)$

Express as a sum or a difference of logarithms.

91. $\log_a \frac{x - y}{\sqrt{x^2 - y^2}}$ 92. $\log_a \sqrt{9 - x^2}$

93. Given that $\log_a x = 2$, $\log_a y = 3$, and $\log_a z = 4$, find

$$\log_a \frac{\sqrt[4]{y^2 z^5}}{\sqrt[4]{x^3 z^{-2}}}$$

Determine whether each of the following is true. Assume that a , x , M , and N are positive.

94. $\log_a M + \log_a N = \log_a (M + N)$
 95. $\log_a M - \log_a N = \log_a \frac{M}{N}$
 96. $\frac{\log_a M}{\log_a N} = \log_a M - \log_a N$
 97. $\frac{\log_a M}{x} = \log_a M^{1/x}$
 98. $\log_a x^3 = 3 \log_a x$
 99. $\log_a 8x = \log_a x + \log_a 8$
 100. $\log_N (MN)^x = x \log_N M + x$

Suppose that $\log_a x = 2$. Find each of the following.

101. $\log_a \left(\frac{1}{x}\right)$ 102. $\log_{1/a} x$

103. Simplify:

$$\log_{10} 11 \cdot \log_{11} 12 \cdot \log_{12} 13 \cdots \log_{998} 999 \cdot \log_{999} 1000.$$

Write each of the following without using logarithms.

104. $\log_a x + \log_a y - mz = 0$
 105. $\ln a - \ln b + xy = 0$

Prove each of the following for any base a and any positive number x .

106. $\log_a \left(\frac{1}{x}\right) = -\log_a x = \log_{1/a} x$

107. $\log_a \left(\frac{x + \sqrt{x^2 - 5}}{5}\right) = -\log_a (x - \sqrt{x^2 - 5})$

Solving Exponential Equations and Logarithmic Equations

5.5

- ▶ Solve exponential equations.
- ▶ Solve logarithmic equations.

▶ Solving Exponential Equations

Equations with variables in the exponents, such as

$$3^x = 20 \quad \text{and} \quad 2^{5x} = 64,$$

are called **exponential equations**.

Sometimes, as is the case with the equation $2^{5x} = 64$, we can write each side as a power of the same number:

$$2^{5x} = 2^6.$$

We can then set the exponents equal and solve:

$$5x = 6$$

$$x = \frac{6}{5}, \text{ or } 1.2.$$

We use the following property to solve exponential equations.

Base–Exponent Property

For any $a > 0, a \neq 1$,

$$a^x = a^y \iff x = y.$$

This property follows from the fact that for any $a > 0, a \neq 1$, $f(x) = a^x$ is a one-to-one function. If $a^x = a^y$, then $f(x) = f(y)$. Then since f is one-to-one, it follows that $x = y$. Conversely, if $x = y$, it follows that $a^x = a^y$, since we are raising a to the same power in each case.

ONE-TO-ONE FUNCTIONS

REVIEW SECTION 5.1

EXAMPLE 1 Solve: $2^{3x-7} = 32$.**Algebraic Solution**

Note that $32 = 2^5$. Thus we can write each side as a power of the same number:

$$2^{3x-7} = 2^5.$$

Since the bases are the same number, 2, we can use the base–exponent property and set the exponents equal:

$$3x - 7 = 5$$

$$3x = 12$$

$$x = 4.$$

Check:

$$\frac{2^{3x-7} = 32}{2^{3(4)-7} \quad ? \quad 32}$$

$$2^{12-7} \quad | \quad 32$$

$$2^5 \quad | \quad 32$$

$$2^5 \quad | \quad 32$$

$$32 \quad | \quad 32 \quad \text{TRUE}$$

The solution is 4.

Visualizing the Solution

When we graph $y = 2^{3x-7}$ and $y = 32$, we find that the first coordinate of the point of intersection of the graphs is 4.

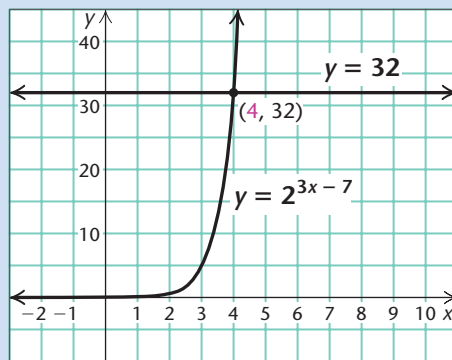

The solution of $2^{3x-7} = 32$ is 4.

➔ **Now Try Exercise 7.**

Another property that is used when solving some exponential and logarithmic equations is as follows.

Property of Logarithmic Equality

For any $M > 0$, $N > 0$, $a > 0$, and $a \neq 1$,

$$\log_a M = \log_a N \leftrightarrow M = N.$$

This property follows from the fact that for any $a > 0$, $a \neq 1$, $f(x) = \log_a x$ is a one-to-one function. If $\log_a x = \log_a y$, then $f(x) = f(y)$. Then since f is one-to-one, it follows that $x = y$. Conversely, if $x = y$, it follows that $\log_a x = \log_a y$, since we are taking the logarithm of the same number in each case.

When it does not seem possible to write each side as a power of the same base, we can use the property of logarithmic equality and take the logarithm with any base on each side and then use the power rule for logarithms.

EXAMPLE 2 Solve: $3^x = 20$.**Algebraic Solution**

We have

$$3^x = 20$$

$$\log 3^x = \log 20$$

**Taking the common
logarithm on both sides
Using the power rule**

$$x \log 3 = \log 20$$

$$x = \frac{\log 20}{\log 3}$$

Dividing by log 3

This is an exact answer. We cannot simplify further, but we can approximate using a calculator:

$$x = \frac{\log 20}{\log 3} \approx 2.7268.$$

We can check this by finding $3^{2.7268}$:

$$3^{2.7268} \approx 20.$$

The solution is about 2.7268.

Visualizing the Solution

We graph $y = 3^x$ and $y = 20$. The first coordinate of the point of intersection of the graphs is the value of x for which $3^x = 20$ and is thus the solution of the equation.

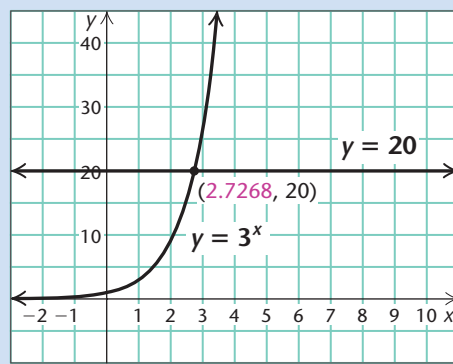

The solution is approximately 2.7268.

Now Try Exercise 11.

In Example 2, we took the common logarithm on both sides of the equation. Any base will give the same result. Let's try base 3. We have

$$3^x = 20$$

$$\log_3 3^x = \log_3 20$$

$$x = \log_3 20 \quad \mathbf{\log_a a^x = x}$$

$$x = \frac{\log 20}{\log 3}$$

Using the change-of-base formula

$$x \approx 2.7268.$$

Note that we must change the base in order to do the final calculation.

EXAMPLE 3 Solve: $e^{0.08t} = 2500$.**Algebraic Solution**

It will make our work easier if we take the natural logarithm when working with equations that have e as a base.

We have

$$e^{0.08t} = 2500$$

$$\ln e^{0.08t} = \ln 2500$$

$$0.08t = \ln 2500$$

$$t = \frac{\ln 2500}{0.08}$$

$$t \approx 97.8.$$

The solution is about 97.8.

Taking the natural logarithm on both sides
Finding the logarithm of a base to a power: $\log_a a^x = x$

Dividing by 0.08

Visualizing the Solution

The first coordinate of the point of intersection of the graphs of $y = e^{0.08t}$ and $y = 2500$ is about 97.8. This is the solution of the equation.

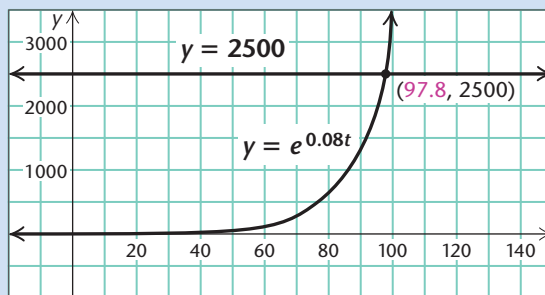

➔ **Now Try Exercise 19.**

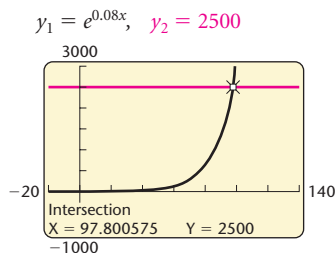
TECHNOLOGY CONNECTION

We can solve the equations in Examples 1–4 using the Intersect method. In Example 3, for instance, we graph $y = e^{0.08x}$ and $y = 2500$ and use the INTERSECT feature to find the coordinates of the point of intersection.

The first coordinate of the point of intersection is the solution of the equation $e^{0.08x} = 2500$. The solution is about 97.8. We could also write the equation in the form $e^{0.08x} - 2500 = 0$ and use the Zero method.

EXAMPLE 4 Solve: $4^{x+3} = 3^{-x}$.

Algebraic Solution

We have

$$4^{x+3} = 3^{-x}$$

$$\log 4^{x+3} = \log 3^{-x}$$

$$(x + 3) \log 4 = -x \log 3$$

$$x \log 4 + 3 \log 4 = -x \log 3$$

$$x \log 4 + x \log 3 = -3 \log 4$$

$$x(\log 4 + \log 3) = -3 \log 4$$

$$x = \frac{-3 \log 4}{\log 4 + \log 3}$$

$$x \approx -1.6737.$$

Taking the common logarithm on both sides

Using the power rule

Removing parentheses

Adding $x \log 3$ and subtracting $3 \log 4$

Factoring on the left

Dividing by $\log 4 + \log 3$

Visualizing the Solution

We graph $y = 4^{x+3}$ and $y = 3^{-x}$. The first coordinate of the point of intersection of the graphs is the value of x for which $4^{x+3} = 3^{-x}$ and is thus the solution of the equation.

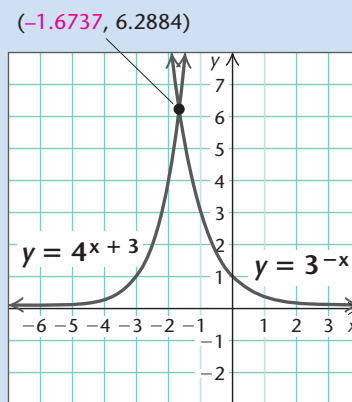

The solution is approximately -1.6737 .

Now Try Exercise 21.

EQUATIONS REDUCIBLE TO QUADRATIC

REVIEW SECTION 3.2

EXAMPLE 5 Solve: $e^x + e^{-x} - 6 = 0$.**Algebraic Solution**

In this case, we have more than one term with x in the exponent:

$$e^x + e^{-x} - 6 = 0$$

$$e^x + \frac{1}{e^x} - 6 = 0$$

Rewriting e^{-x} with a positive exponent

$$e^{2x} + 1 - 6e^x = 0.$$

Multiplying by e^x on both sides

This equation is reducible to quadratic with $u = e^x$:

$$u^2 - 6u + 1 = 0.$$

We use the quadratic formula with $a = 1$, $b = -6$, and $c = 1$:

$$u = \frac{-b \pm \sqrt{b^2 - 4ac}}{2a}$$

$$u = \frac{-(-6) \pm \sqrt{(-6)^2 - 4 \cdot 1 \cdot 1}}{2 \cdot 1}$$

$$u = \frac{6 \pm \sqrt{32}}{2} = \frac{6 \pm 4\sqrt{2}}{2}$$

$$u = 3 \pm 2\sqrt{2}$$

$$e^x = 3 \pm 2\sqrt{2}. \quad \text{Replacing } u \text{ with } e^x$$

We now take the natural logarithm on both sides:

$$\ln e^x = \ln(3 \pm 2\sqrt{2})$$

$$x = \ln(3 \pm 2\sqrt{2}). \quad \text{Using } \ln e^x = x$$

Approximating each of the solutions, we obtain 1.76 and -1.76 .

Visualizing the Solution

The solutions of the equation

$$e^x + e^{-x} - 6 = 0$$

are the zeros of the function

$$f(x) = e^x + e^{-x} - 6.$$

Note that the solutions are also the first coordinates of the x -intercepts of the graph of the function.

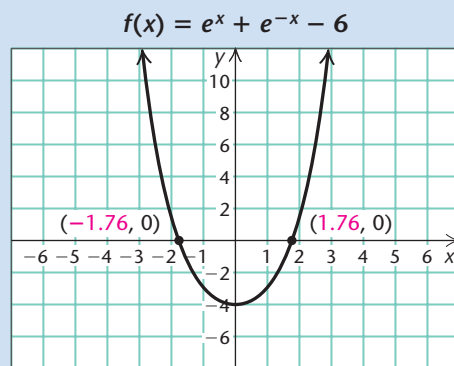

The leftmost zero is about -1.76 . The zero on the right is about 1.76 . The solutions of the equation are approximately -1.76 and 1.76 .

Now Try Exercise 25.

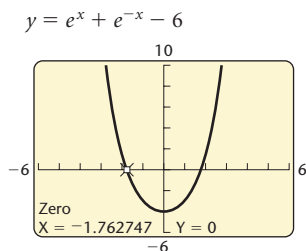
TECHNOLOGY CONNECTION

We can use the Zero method in Example 5 to solve the equation $e^x + e^{-x} - 6 = 0$. We graph the function $y = e^x + e^{-x} - 6$ and use the ZERO feature to find the zeros.

The leftmost zero is about -1.76 . Using the ZERO feature one more time, we find that the other zero is about 1.76 .

► Solving Logarithmic Equations

Equations containing variables in logarithmic expressions, such as $\log_2 x = 4$ and $\log x + \log(x + 3) = 1$, are called **logarithmic equations**. To solve logarithmic equations algebraically, we first try to obtain a single logarithmic expression on one side and then write an equivalent exponential equation.

EXAMPLE 6 Solve: $\log_3 x = -2$.

Algebraic Solution

We have

$$\log_3 x = -2$$

$$3^{-2} = x$$

Converting to an exponential equation

$$\frac{1}{3^2} = x$$

$$\frac{1}{9} = x.$$

Check:

$$\log_3 x = -2$$

$$\log_3 \frac{1}{9} \stackrel{?}{=} -2$$

$$\log_3 3^{-2}$$

$$-2 \quad -2 \quad \text{TRUE}$$

The solution is $\frac{1}{9}$.

Visualizing the Solution

When we graph $y = \log_3 x$ and $y = -2$, we find that the first coordinate of the point of intersection of the graphs is $\frac{1}{9}$.

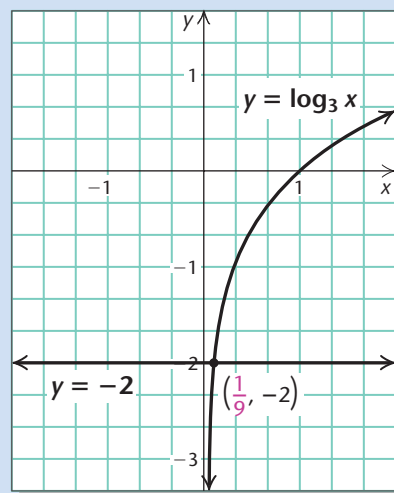

The solution of $\log_3 x = -2$ is $\frac{1}{9}$.

➔ Now Try Exercise 33.

EXAMPLE 7 Solve: $\log x + \log(x + 3) = 1$.**Algebraic Solution**

In this case, we have common logarithms. Writing the base of 10 will help us understand the problem:

$$\log_{10} x + \log_{10}(x + 3) = 1$$

$$\log_{10}[x(x + 3)] = 1$$

**Using the product rule
to obtain a single logarithm
Writing an equivalent
exponential equation**

$$x(x + 3) = 10^1$$

$$x^2 + 3x = 10$$

$$x^2 + 3x - 10 = 0$$

$$(x - 2)(x + 5) = 0$$

Factoring

$$x - 2 = 0 \quad \text{or} \quad x + 5 = 0$$

$$x = 2 \quad \text{or} \quad x = -5.$$

Check:

For 2:

$$\log x + \log(x + 3) = 1$$

$$\log 2 + \log(2 + 3) \stackrel{?}{=} 1$$

$$\log 2 + \log 5$$

$$\log(2 \cdot 5)$$

$$\log(10)$$

$$1 \quad | \quad 1 \quad \text{TRUE}$$

For -5:

$$\log x + \log(x + 3) = 1$$

$$\log(-5) + \log(-5 + 3) \stackrel{?}{=} 1 \quad \text{FALSE}$$

The number -5 is not a solution because negative numbers do not have real-number logarithms. The solution is 2.

Visualizing the Solution

The solution of the equation

$$\log x + \log(x + 3) = 1$$

is the zero of the function

$$f(x) = \log x + \log(x + 3) - 1.$$

The solution is also the first coordinate of the x -intercept of the graph of the function.

$$f(x) = \log x + \log(x + 3) - 1$$

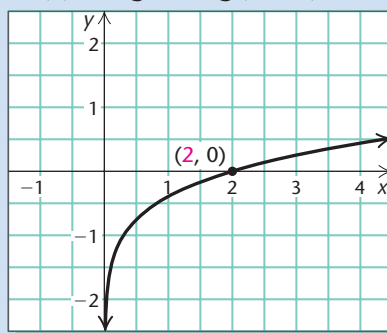

The solution of the equation is 2. From the graph, we can easily see that there is only one solution.

Now Try Exercise 41.

TECHNOLOGY CONNECTION

In Example 7, we can graph the equations

$$y_1 = \log x + \log(x + 3)$$

and

$$y_2 = 1$$

and use the Intersect method. The first coordinate of the point of intersection is the solution of the equation.

We could also graph the function

$$y = \log x + \log(x + 3) - 1$$

and use the Zero method. The zero of the function is the solution of the equation.

With either method, we see that the solution is 2.

Note that the graphical solution gives only the one *true* solution.

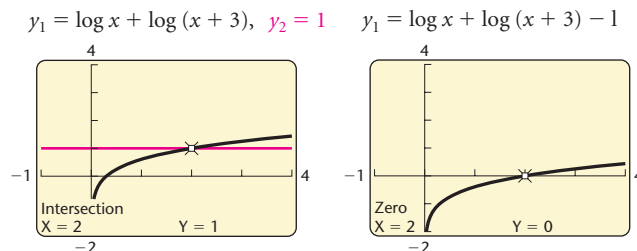

EXAMPLE 8 Solve: $\log_3(2x - 1) - \log_3(x - 4) = 2$.

Algebraic Solution

We have

$$\log_3(2x - 1) - \log_3(x - 4) = 2$$

$$\log_3 \frac{2x - 1}{x - 4} = 2$$

Using the quotient rule

$$\frac{2x - 1}{x - 4} = 3^2$$

Writing an equivalent exponential equation

$$\frac{2x - 1}{x - 4} = 9$$

$$(x - 4) \cdot \frac{2x - 1}{x - 4} = 9(x - 4)$$

Multiplying by the LCD, $x - 4$

$$2x - 1 = 9x - 36$$

$$35 = 7x$$

$$5 = x.$$

Check:

$$\begin{array}{r|l} \log_3(2x - 1) - \log_3(x - 4) = 2 & \\ \hline \log_3(2 \cdot 5 - 1) - \log_3(5 - 4) \stackrel{?}{=} 2 & \\ \log_3 9 - \log_3 1 & \\ 2 - 0 & \\ 2 & 2 \quad \text{TRUE} \end{array}$$

The solution is 5.

Visualizing the Solution

We see that the first coordinate of the point of intersection of the graphs of

$$y = \log_3(2x - 1) - \log_3(x - 4)$$

and

$$y = 2$$

is 5.

$$y = \log_3(2x - 1) - \log_3(x - 4)$$

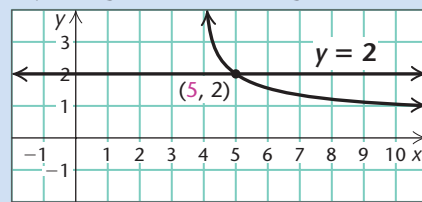

The solution is 5.

EXAMPLE 9 Solve: $\ln(4x + 6) - \ln(x + 5) = \ln x$.

Algebraic Solution

We have

$$\ln(4x + 6) - \ln(x + 5) = \ln x$$

$$\ln \frac{4x + 6}{x + 5} = \ln x$$

$$\frac{4x + 6}{x + 5} = x$$

$$(x + 5) \cdot \frac{4x + 6}{x + 5} = x(x + 5)$$

$$4x + 6 = x^2 + 5x$$

$$0 = x^2 + x - 6$$

$$0 = (x + 3)(x - 2) \quad \text{Factoring}$$

$$x + 3 = 0 \quad \text{or} \quad x - 2 = 0$$

$$x = -3 \quad \text{or} \quad x = 2.$$

The number -3 is not a solution because $4(-3) + 6 = -6$ and $\ln(-6)$ is not a real number. The value 2 checks and is the solution.



Visualizing the Solution

The solution of the equation

$$\ln(4x + 6) - \ln(x + 5) = \ln x$$

is the zero of the function

$$f(x) = \ln(4x + 6) - \ln(x + 5) - \ln x.$$

The solution is also the first coordinate of the x -intercept of the graph of the function.

$$f(x) = \ln(4x + 6) - \ln(x + 5) - \ln x$$

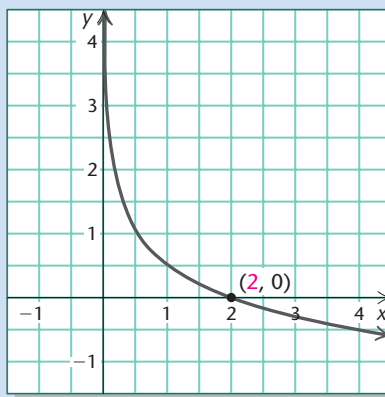

The solution of the equation is 2 . From the graph, we can easily see that there is only one solution.

 **Now Try Exercise 43.**

5.5

Exercise Set

Solve the exponential equation.

1. $3^x = 81$

2. $2^x = 32$

3. $2^{2x} = 8$

4. $3^{7x} = 27$

5. $2^x = 33$

6. $2^x = 40$

7. $5^{4x-7} = 125$

8. $4^{3x-5} = 16$

9. $27 = 3^{5x} \cdot 9^{x^2}$

10. $3^{x^2+4x} = \frac{1}{27}$

11. $84^x = 70$

13. $10^{-x} = 5^{2x}$

15. $e^{-c} = 5^{2c}$

17. $e^t = 1000$

19. $e^{-0.03t} = 0.08$

21. $3^x = 2^{x-1}$

12. $28^x = 10^{-3x}$

14. $15^x = 30$

16. $e^{4t} = 200$

18. $e^{-t} = 0.04$

20. $1000e^{0.09t} = 5000$

22. $5^{x+2} = 4^{1-x}$

23. $(3.9)^x = 48$ 24. $250 - (1.87)^x = 0$
 25. $e^x + e^{-x} = 5$ 26. $e^x - 6e^{-x} = 1$
 27. $3^{2x-1} = 5^x$ 28. $2^{x+1} = 5^{2x}$
 29. $2e^x = 5 - e^{-x}$ 30. $e^x + e^{-x} = 4$

Solve the logarithmic equation.

31. $\log_5 x = 4$ 32. $\log_2 x = -3$
 33. $\log x = -4$ 34. $\log x = 1$
 35. $\ln x = 1$ 36. $\ln x = -2$
 37. $\log_{64} \frac{1}{4} = x$ 38. $\log_{125} \frac{1}{25} = x$
 39. $\log_2(10 + 3x) = 5$
 40. $\log_5(8 - 7x) = 3$
 41. $\log x + \log(x - 9) = 1$
 42. $\log_2(x + 1) + \log_2(x - 1) = 3$
 43. $\log_2(x + 20) - \log_2(x + 2) = \log_2 x$
 44. $\log(x + 5) - \log(x - 3) = \log 2$
 45. $\log_8(x + 1) - \log_8 x = 2$
 46. $\log x - \log(x + 3) = -1$
 47. $\log x + \log(x + 4) = \log 12$
 48. $\log_3(x + 14) - \log_3(x + 6) = \log_3 x$
 49. $\log(x + 8) - \log(x + 1) = \log 6$
 50. $\ln x - \ln(x - 4) = \ln 3$
 51. $\log_4(x + 3) + \log_4(x - 3) = 2$
 52. $\ln(x + 1) - \ln x = \ln 4$
 53. $\log(2x + 1) - \log(x - 2) = 1$
 54. $\log_5(x + 4) + \log_5(x - 4) = 2$
 55. $\ln(x + 8) + \ln(x - 1) = 2 \ln x$
 56. $\log_3 x + \log_3(x + 1) = \log_3 2 + \log_3(x + 3)$

Solve.

57. $\log_6 x = 1 - \log_6(x - 5)$
 58. $2^{x^2-9x} = \frac{1}{256}$
 59. $9^{x-1} = 100(3^x)$
 60. $2 \ln x - \ln 5 = \ln(x + 10)$
 61. $e^x - 2 = -e^{-x}$
 62. $2 \log 50 = 3 \log 25 + \log(x - 2)$

Skill Maintenance

In Exercises 63–66:

- a) Find the vertex.
 b) Find the axis of symmetry.
 c) Determine whether there is a maximum or minimum value and find that value.

63. $g(x) = x^2 - 6$
 64. $f(x) = -x^2 + 6x - 8$
 65. $G(x) = -2x^2 - 4x - 7$
 66. $H(x) = 3x^2 - 12x + 16$

Synthesis

Solve using any method.

67. $\frac{e^x + e^{-x}}{e^x - e^{-x}} = 3$
 68. $\frac{5^x - 5^{-x}}{5^x + 5^{-x}} = 8$
 69. $\ln(\log x) = 0$
 70. $\ln(\ln x) = 2$
 71. $\sqrt{\ln x} = \ln \sqrt{x}$
 72. $\ln \sqrt[4]{x} = \sqrt{\ln x}$
 73. $(\log_3 x)^2 - \log_3 x^2 = 3$
 74. $\log_3(\log_4 x) = 0$
 75. $\ln x^2 = (\ln x)^2$
 76. $(\log x)^2 - \log x^2 = 3$
 77. $5^{2x} - 3 \cdot 5^x + 2 = 0$
 78. $e^{2x} - 9 \cdot e^x + 14 = 0$
 79. $\log_3 |x| = 2$
 80. $x \left(\ln \frac{1}{6} \right) = \ln 6$
 81. $\ln x^{\ln x} = 4$
 82. $x^{\log x} = \frac{x^3}{100}$
 83. $\frac{\sqrt{(e^{2x} \cdot e^{-5x})^{-4}}}{e^x \div e^{-x}} = e^7$
 84. $\frac{(e^{3x+1})^2}{e^4} = e^{10x}$
 85. $|\log_5 x| + 3 \log_5 |x| = 4$

86. $e^x < \frac{4}{5}$

87. $|2^{x^2} - 8| = 3$

88. Given that $a = \log_8 225$ and $b = \log_2 15$, express a as a function of b .

89. Given that

$$\begin{aligned}\log_2[\log_3(\log_4 x)] &= \log_3[\log_2(\log_4 y)] \\ &= \log_4[\log_3(\log_2 z)] \\ &= 0,\end{aligned}$$

find $x + y + z$.90. Given that $a = (\log_{125} 5)^{\log_5 125}$, find the value of $\log_3 a$.91. Given that $f(x) = e^x - e^{-x}$, find $f^{-1}(x)$ if it exists.

Applications and Models: Growth and Decay; Compound Interest

5.6

- ▶ Solve applied problems involving exponential growth and decay.
- ▶ Solve applied problems involving compound interest.

Exponential functions and logarithmic functions with base e are rich in applications to many fields such as business, science, psychology, and sociology.

▶ Population Growth

The function

$$P(t) = P_0 e^{kt}, \quad k > 0$$

is a model of many kinds of population growth, whether it be a population of people, bacteria, cell phones, or money. In this function, P_0 is the population at time 0, P is the population after time t , and k is called the **exponential growth rate**. The graph of such an equation is shown at left.

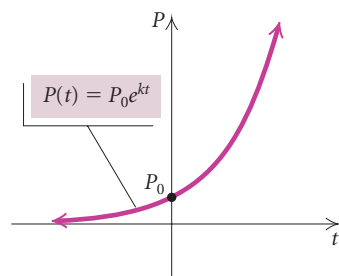

EXAMPLE 1 *Population Growth of Mexico.* In 2009, the population of Mexico was about 111.2 million, and the exponential growth rate was 1.13% per year (*Source: CIA World Factbook, 2009*).

- a) Find the exponential growth function.
- b) Estimate the population in 2014.
- c) After how long will the population be double what it was in 2009?

TECHNOLOGY CONNECTION

We can find function values using a graphing calculator. Below, we find $P(5)$ from Example 1(b) with the VALUE feature from the CALC menu. We see that $P(5) \approx 117.7$.

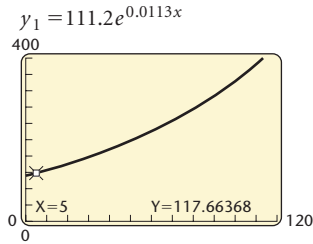

Solution

- a) At $t = 0$ (2009), the population was 111.2 million and the exponential growth rate was 1.13% per year. We substitute 111.2 for P_0 and 1.13%, or 0.0113, for k to obtain the exponential growth function

$$P(t) = 111.2e^{0.0113t},$$

where t is the number of years after 2009 and $P(t)$ is in millions.

- b) In 2014, $t = 5$; that is, 5 years have passed since 2009. To find the population in 2014, we substitute 5 for t :

$$P(5) = 111.2e^{0.0113(5)} = 111.2e^{0.0565} \approx 117.7.$$

The population will be about 117.7 million, or 117,700,000, in 2014.

- c) We are looking for the time T for which $P(T) = 2 \cdot 111.2$, or 222.4. The number T is called the **doubling time**. To find T , we solve the equation

$$222.4 = 111.2e^{0.0113T}.$$

Algebraic Solution

We have

$$222.4 = 111.2e^{0.0113T}$$

$$2 = e^{0.0113T}$$

$$\ln 2 = \ln e^{0.0113T}$$

$$\ln 2 = 0.0113T$$

$$\frac{\ln 2}{0.0113} = T$$

$$61.3 \approx T.$$

The population of Mexico will be double what it was in 2009 about 61.3 years after 2009.

Substituting 222.4 for $P(T)$

Dividing by 111.2

Taking the natural logarithm on both sides

$\ln e^x = x$

Dividing by 0.0113

Visualizing the Solution

From the graph of $y = 222.4$ and $y = 111.2e^{0.0113T}$, we see that the first coordinate of the point of intersection of the graphs is about 61.3.

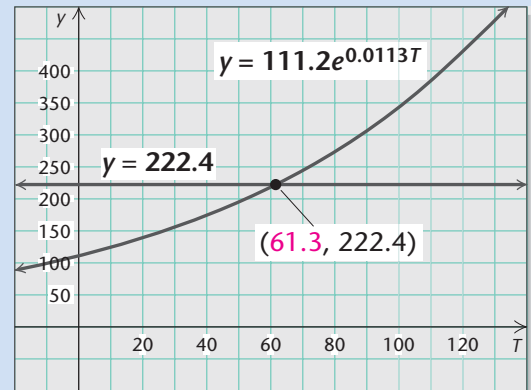

The solution of the equation is approximately 61.3.

TECHNOLOGY CONNECTION

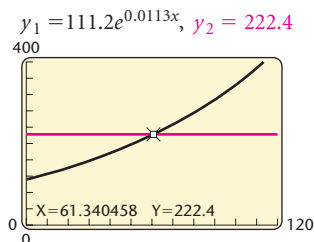

Using the Intersect method in Example 1(c), we graph the equations

$$y_1 = 111.2e^{0.0113x} \quad \text{and} \quad y_2 = 222.4$$

and find the first coordinate of their point of intersection. It is about 61.3, so the population of Mexico will be double that of 2009 about 61.3 years after 2009.

STUDY TIP

Newspapers and magazines are full of mathematical applications, many of which follow the exponential model. Find an application and share it with your class. As you obtain higher math skills, you will more readily observe the world from a mathematical perspective. Math courses become more interesting when we connect the concepts to the real world.

► Interest Compounded Continuously

When interest is paid on interest, we call it **compound interest**. Suppose that an amount P_0 is invested in a savings account at interest rate k **compounded continuously**. The amount $P(t)$ in the account after t years is given by the exponential function

$$P(t) = P_0e^{kt}.$$

EXAMPLE 2 *Interest Compounded Continuously.* Suppose that \$2000 is invested at interest rate k , compounded continuously, and grows to \$2504.65 in 5 years.

- What is the interest rate?
- Find the exponential growth function.
- What will the balance be after 10 years?
- After how long will the \$2000 have doubled?

Solution

- a) At $t = 0$, $P(0) = P_0 = \$2000$. Thus the exponential growth function is of the form

$$P(t) = 2000e^{kt}.$$

We know that $P(5) = \$2504.65$. We substitute and solve for k :

$$2504.65 = 2000e^{k(5)} \quad \text{Substituting 2504.65 for } P(t) \text{ and 5 for } t$$

$$2504.65 = 2000e^{5k}$$

$$\frac{2504.65}{2000} = e^{5k} \quad \text{Dividing by 2000}$$

$$\ln \frac{2504.65}{2000} = \ln e^{5k} \quad \text{Taking the natural logarithm}$$

$$\ln \frac{2504.65}{2000} = 5k \quad \text{Using } \ln e^x = x$$

$$\frac{\ln \frac{2504.65}{2000}}{5} = k \quad \text{Dividing by 5}$$

$$0.045 \approx k.$$

The interest rate is about 0.045, or 4.5%.

TECHNOLOGY CONNECTION

We can also find k in Example 2(a) by graphing the equations

$$y_1 = 2000e^{5x}$$

and

$$y_2 = 2504.65$$

and use the Intersect feature to approximate the first coordinate of the point of intersection.

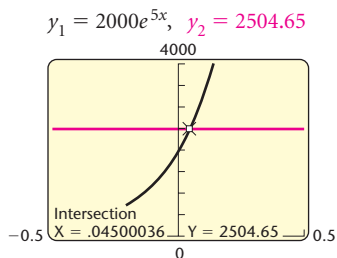

The interest rate is about 0.045, or 4.5%.

- b) Substituting 0.045 for k in the function $P(t) = 2000e^{kt}$, we see that the exponential growth function is

$$P(t) = 2000e^{0.045t}.$$

- c) The balance after 10 years is

$$P(10) = 2000e^{0.045(10)} = 2000e^{0.45} \approx \$3136.62.$$

- d) To find the doubling time T , we set $P(T) = 2 \cdot P_0 = 2 \cdot \$2000 = \$4000$ and solve for T . We solve

$$4000 = 2000e^{0.045T}.$$

Algebraic Solution

We have

$$4000 = 2000e^{0.045T}$$

$$2 = e^{0.045T} \quad \text{Dividing by 2000}$$

$$\ln 2 = \ln e^{0.045T} \quad \text{Taking the natural logarithm}$$

$$\ln 2 = 0.045T \quad \text{In } e^x = x$$

$$\frac{\ln 2}{0.045} = T \quad \text{Dividing by 0.045}$$

$$15.4 \approx T.$$

Thus the original investment of \$2000 will double in about 15.4 years.



Visualizing the Solution

The solution of the equation

$$4000 = 2000e^{0.045T}$$

or

$$2000e^{0.045T} - 4000 = 0,$$

is the zero of the function

$$y = 2000e^{0.045T} - 4000.$$

Let's observe the zero from the graph shown here.

$$y = 2000e^{0.045T} - 4000$$

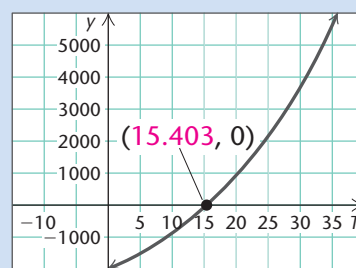

The zero is about 15.4. Thus the solution of the equation is approximately 15.4.

Now Try Exercise 7.

TECHNOLOGY CONNECTION

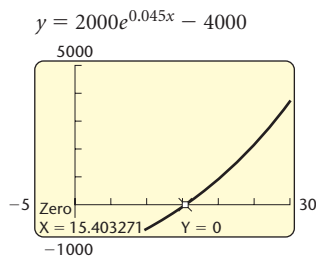

The money in Example 2 will have doubled when $P(t) = 2 \cdot P_0 = 4000$, or when $2000e^{0.045t} = 4000$. We use the Zero method. We graph the equation

$$y = 2000e^{0.045x} - 4000$$

and find the zero of the function. The zero of the function is the solution of the equation. The zero is about 15.4, so the original investment of \$2000 will double in about 15.4 years.

We can find a general expression relating the growth rate k and the doubling time T by solving the following equation:

$$2P_0 = P_0e^{kT} \quad \text{Substituting } 2P_0 \text{ for } P \text{ and } T \text{ for } t$$

$$2 = e^{kT} \quad \text{Dividing by } P_0$$

$$\ln 2 = \ln e^{kT} \quad \text{Taking the natural logarithm}$$

$$\ln 2 = kT \quad \text{Using } \ln e^x = x$$

$$\frac{\ln 2}{k} = T.$$

Growth Rate and Doubling Time

The growth rate k and the doubling time T are related by

$$kT = \ln 2, \quad \text{or} \quad k = \frac{\ln 2}{T}, \quad \text{or} \quad T = \frac{\ln 2}{k}.$$

Note that the relationship between k and T does not depend on P_0 .

EXAMPLE 3 Population Growth. The population of Kenya is now doubling every 25.8 years. (Source: CIA World Factbook, 2009). What is the exponential growth rate?

Solution We have

$$k = \frac{\ln 2}{T} = \frac{\ln 2}{25.8} \approx 0.0269 \approx 2.69\%.$$

The growth rate of the population of Kenya is about 2.69% per year.

Now Try Exercise 3(e).

► Models of Limited Growth

The model $P(t) = P_0e^{kt}$, $k > 0$, has many applications involving unlimited population growth. However, in some populations, there can be factors that prevent a population from exceeding some limiting value—perhaps a

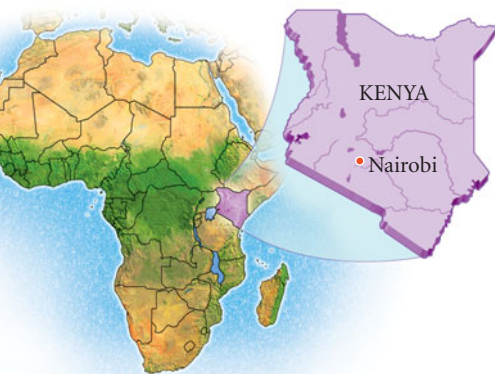

limitation on food, living space, or other natural resources. One model of such growth is

$$P(t) = \frac{a}{1 + be^{-kt}}.$$

This is called a **logistic function**. This function increases toward a *limiting value* a as $t \rightarrow \infty$. Thus, $y = a$ is the horizontal asymptote of the graph of $P(t)$.

EXAMPLE 4 *Limited Population Growth in a Lake.* A lake is stocked with 400 fish of a new variety. The size of the lake, the availability of food, and the number of other fish restrict the growth of that type of fish in the lake to a limiting value of 2500. The population gets closer and closer to this limiting value, but never reaches it. The population of fish in the lake after time t , in months, is given by the function

$$P(t) = \frac{2500}{1 + 5.25e^{-0.32t}}.$$

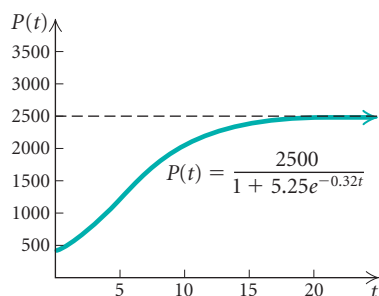

The graph of $P(t)$ is the curve shown at left. Note that this function increases toward a limiting value of 2500. The graph has $y = 2500$ as a horizontal asymptote. Find the population after 0, 1, 5, 10, 15, and 20 months.

Solution Using a calculator, we compute the function values. We find that

$$P(0) = 400, \quad P(10) \approx 2059,$$

$$P(1) \approx 520, \quad P(15) \approx 2396,$$

$$P(5) \approx 1214, \quad P(20) \approx 2478.$$

Thus the population will be about 400 after 0 months, 520 after 1 month, 1214 after 5 months, 2059 after 10 months, 2396 after 15 months, and 2478 after 20 months.

 **Now Try Exercise 17.**

Another model of limited growth is provided by the function

$$P(t) = L(1 - e^{-kt}), \quad k > 0,$$

which is shown graphed below. This function also increases toward a limiting value L , as $t \rightarrow \infty$, so $y = L$ is the horizontal asymptote of the graph of $P(t)$.

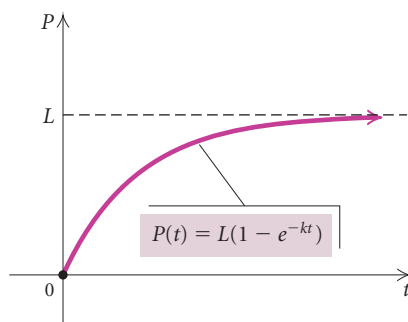

How can scientists determine that an animal bone has lost 30% of its carbon-14? The assumption is that the percentage of carbon-14 in the atmosphere is the same as that in living plants and animals. When a plant or an animal dies, the amount of carbon-14 that it contains decays exponentially. A scientist can burn an animal bone and use a Geiger counter to determine the percentage of the smoke that is carbon-14. The amount by which this varies from the percentage in the atmosphere tells how much carbon-14 has been lost.

The process of carbon-14 dating was developed by the American chemist Willard E. Libby in 1952. It is known that the radioactivity in a living plant is 16 disintegrations per gram per minute. Since the half-life of carbon-14 is 5750 years, an object with an activity of 8 disintegrations per gram per minute is 5750 years old, one with an activity of 4 disintegrations per gram per minute is 11,500 years old, and so on. Carbon-14 dating can be used to measure the age of objects up to 40,000 years old. Beyond such an age, it is too difficult to measure the radioactivity and some other method would have to be used.

Carbon-14 dating was used to find the age of the Dead Sea Scrolls. It was also used to refute the authenticity of the Shroud of Turin, presumed to have covered the body of Christ.

► Exponential Decay

The function

$$P(t) = P_0 e^{-kt}, \quad k > 0$$

is an effective model of the decline, or decay, of a population. An example is the decay of a radioactive substance. In this case, P_0 is the amount of the substance at time $t = 0$, and $P(t)$ is the amount of the substance left after time t , where k is a positive constant that depends on the situation. The constant k is called the **decay rate**.

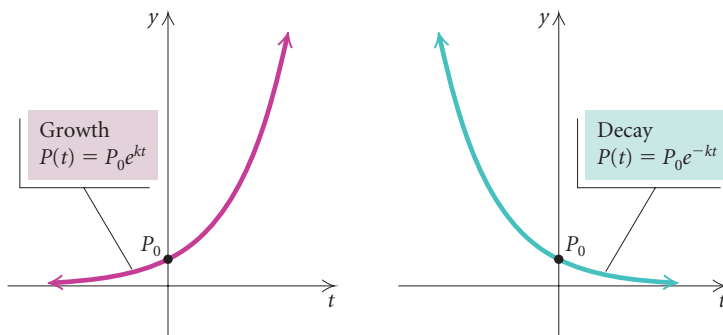

The **half-life** of bismuth (Bi-210) is 5 days. This means that half of an amount of bismuth will cease to be radioactive in 5 days. The effect of half-life T for nonnegative inputs is shown in the graph on the following page. The exponential function gets close to 0, but never reaches 0, as t gets very large.

Thus, according to an exponential decay model, a radioactive substance never completely decays.

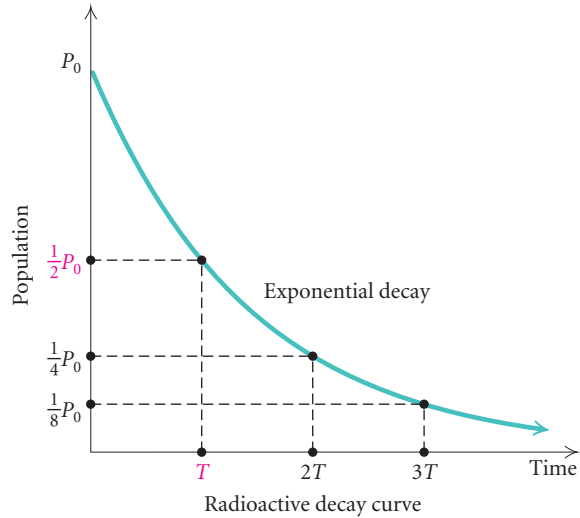

We can find a general expression relating the decay rate k and the half-life time T by solving the following equation:

$$\frac{1}{2}P_0 = P_0 e^{-kT} \quad \text{Substituting } \frac{1}{2}P_0 \text{ for } P \text{ and } T \text{ for } t$$

$$\frac{1}{2} = e^{-kT} \quad \text{Dividing by } P_0$$

$$\ln \frac{1}{2} = \ln e^{-kT} \quad \text{Taking the natural logarithm}$$

$$\ln 2^{-1} = -kT \quad \frac{1}{2} = 2^{-1}; \ln e^x = x$$

$$-\ln 2 = -kT \quad \text{Using the power rule}$$

$$\frac{\ln 2}{k} = T. \quad \text{Dividing by } -k$$

Decay Rate and Half-Life

The decay rate k and the half-life T are related by

$$kT = \ln 2, \quad \text{or} \quad k = \frac{\ln 2}{T}, \quad \text{or} \quad T = \frac{\ln 2}{k}.$$

Note that the relationship between decay rate and half-life is the same as that between growth rate and doubling time.

EXAMPLE 5 Carbon Dating. The radioactive element carbon-14 has a half-life of 5750 years. The percentage of carbon-14 present in the remains of organic matter can be used to determine the age of that organic matter. Archaeologists discovered that the linen wrapping from one of the Dead Sea Scrolls had lost 22.3% of its carbon-14 at the time it was found. How old was the linen wrapping?



In 1947, a Bedouin youth looking for a stray goat climbed into a cave at Kirbet Qumran on the shores of the Dead Sea near Jericho and came upon earthenware jars containing an incalculable treasure of ancient manuscripts. Shown here are fragments of those Dead Sea Scrolls, a portion of some 600 or so texts found so far and which concern the Jewish books of the Bible. Officials date them before 70 A.D., making them the oldest Biblical manuscripts by 1000 years.

Solution We first find k when the half-life T is 5750 years:

$$k = \frac{\ln 2}{T}$$

$$k = \frac{\ln 2}{5750} \quad \text{Substituting 5750 for } T$$

$$k = 0.00012.$$

Now we have the function

$$P(t) = P_0 e^{-0.00012t}.$$

(This function can be used for any subsequent carbon-dating problem.) If the linen wrapping has lost 22.3% of its carbon-14 from an initial amount P_0 , then $77.7\% P_0$ is the amount present. To find the age t of the wrapping, we solve the following equation for t :

$$77.7\% P_0 = P_0 e^{-0.00012t} \quad \text{Substituting } 77.7\% P_0 \text{ for } P$$

$$0.777 = e^{-0.00012t} \quad \text{Dividing by } P_0 \text{ and writing } 77.7\% \text{ as } 0.777$$

$$\ln 0.777 = \ln e^{-0.00012t} \quad \text{Taking the natural logarithm on both sides}$$

$$\ln 0.777 = -0.00012t \quad \ln e^x = x$$

$$\frac{\ln 0.777}{-0.00012} = t \quad \text{Dividing by } -0.00012$$

$$2103 \approx t.$$

Thus the linen wrapping on the Dead Sea Scrolls was about 2103 years old when it was found.

 **Now Try Exercise 9.**

5.6

Exercise Set

1. **World Population Growth.** In 2009, the world population was 6.8 billion. The exponential growth rate was 1.13% per year.

World Population Growth
1 A.D. to 2009

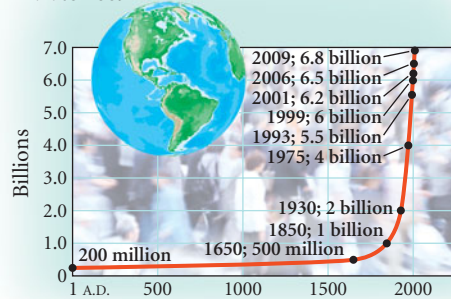

Sources: U.S. Census Bureau; International Data Base;
World Population Profile

- a) Find the exponential growth function.
b) Estimate the population of the world in 2012 and in 2020.
c) When will the world population be 8 billion?
d) Find the doubling time.
2. **Population Growth of Rabbits.** Under ideal conditions, a population of rabbits has an exponential growth rate of 11.7% per day. Consider an initial population of 100 rabbits.
- a) Find the exponential growth function.
b) What will the population be after 7 days? after 2 weeks?
c) Find the doubling time.



3. **Population Growth.** Complete the following table.

Country	Growth Rate, k	Doubling Time, T
a) United States		70.7 yr
b) Venezuela		45.9 yr
c) Ethiopia	3.21%	
d) Australia	1.20%	
e) Denmark		248 yr
f) Laos	2.32%	
g) India	1.40%	
h) China		105.0 yr
i) Tanzania		34.0 yr
j) Haiti	1.84%	

4. **U.S. Exports.** United States exports increased from \$12 billion in 1950 to \$1.550 trillion, or \$1550 billion, in 2009 (Sources: www.dlc.org; U.S. Department of Commerce).



Assuming that the exponential growth model applies:

- a) Find the value of k and write the function.
b) Estimate the value of exports, in billions, in 1972, in 2001, and in 2015. Round to the nearest tenth of a billion.
5. **Population Growth of Haiti.** The population of Haiti has a growth rate of 1.6% per year. In 2009, the

population was 9,035,536, and the land area of Haiti is 32,961,561,600 square yards. (Source: *Statistical Abstract of the United States*) Assuming this growth rate continues and is exponential, after how long will there be one person for every square yard of land?



6. **Picasso Painting.** In May 2010, a 1932 painting, *Nude, Green Leaves, and Bust*, by Pablo Picasso, sold at a New York City art auction for \$106.5 million to an anonymous buyer. This is a record price for any work of art sold at auction. The painting had belonged to the estate of Sydney and Francis Brody who bought it for \$17,000 in 1952 from a New York art dealer, who had acquired it from Picasso in 1936. (Sources: Associated Press, "Picasso Painting Fetches World Record \$106.5M at NYC Auction," by Ula Inlytzky, May 4, 2010; Online Associated Newspapers, May 6, 2010)

Assuming that the value A_0 of the painting has grown exponentially:

- Find the value of k , and determine the exponential growth function, assuming $A_0 = 17,000$ and t is the number of years since 1952.
 - Estimate the value of the painting in 2020.
 - What is the doubling time for the value of the painting?
 - After how long will the value of the painting be \$240 million, assuming there is no change in the growth rate?
7. **Interest Compounded Continuously.** Suppose that \$10,000 is invested at an interest rate of 5.4% per year, compounded continuously.
- Find the exponential function that describes the amount in the account after time t , in years.
 - What is the balance after 1 year? 2 years? 5 years? 10 years?
 - What is the doubling time?

8. **Interest Compounded Continuously.** Complete the following table.

	Initial Investment at $t = 0, P_0$	Interest Rate, k	Doubling Time, T	Amount After 5 Years
a)	\$35,000	3.2%	<input type="text"/>	<input type="text"/>
b)	\$5000	<input type="text"/>	<input type="text"/>	\$7,130.90
c)	<input type="text"/>	5.6%	<input type="text"/>	\$9923.47
d)	<input type="text"/>	<input type="text"/>	11 yr	\$17,539.32
e)	\$109,000	<input type="text"/>	<input type="text"/>	\$136,503.18
f)	<input type="text"/>	<input type="text"/>	46.2 yr	\$19,552.82

9. **Carbon Dating.** In 1970, Amos Flora of Flora, Indiana, discovered teeth and jawbones while dredging a creek. Scientists discovered that the bones were from a mastodon and had lost 77.2% of their carbon-14. How old were the bones at the time they were discovered? (Sources: "Farm Yields Bones Thousands of Years Old," by Dan McFeely, *Indianapolis Star*, October 20, 2008; Field Museum of Chicago, Bill Turnbull, anthropologist)



10. **Tomb in the Valley of the Kings.** In February 2006, in the Valley of the Kings in Egypt, a team of archaeologists uncovered the first tomb since King Tut's tomb was found in 1922. The tomb contained five wooden sarcophagi that contained mummies. The archaeologists believe that the mummies are from the 18th Dynasty, about 3300 to 3500 years ago.

Determine the amount of carbon-14 that the mummies have lost.



- b) Estimate the number of farms in 2011 and in 2015.
c) At this decay rate, when will only 1,000,000 farms remain?



11. **Radioactive Decay.** Complete the following table.

Radioactive Substance	Decay Rate, k	Half-Life T
a) Polonium (Po-218)	<input type="text"/>	3.1 min
b) Lead (Pb-210)	<input type="text"/>	22.3 yr
c) Iodine (I-125)	1.15% per day	<input type="text"/>
d) Krypton (Kr-85)	6.5% per year	<input type="text"/>
e) Strontium (Sr-90)	<input type="text"/>	29.1 yr
f) Uranium (U-232)	<input type="text"/>	70.0 yr
g) Plutonium (Pu-239)	<input type="text"/>	24,100 yr

12. **Number of Farms.** The number N of farms in the United States has declined continually since 1950. In 1950, there were 5.6 million farms, and in 2008 that number had decreased to 2.2 million (Sources: U.S. Department of Agriculture; National Agricultural Statistics Service).

Assuming that the number of farms decreased according to the exponential decay model:

- a) Find the value of k , and write an exponential function that describes the number of farms after time t , in years, where t is the number of years since 1950.

13. **Solar Power.** Photovoltaic solar power has become more affordable in recent years. Solar-power plants project that the average cost per watt of electricity generated by solar panels will decrease exponentially as shown in the graph below.

Cost of Solar Power

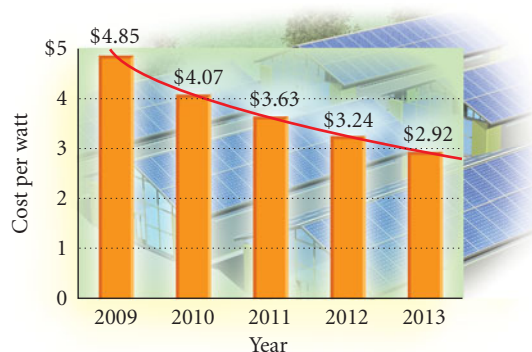

Source: Gartner; USA TODAY, April 12, 2010

Assuming that the cost per watt of electricity generated by solar panels will decrease according to the exponential decay model:

- a) Using the data for 2009 and 2013, find the value of k , and write an exponential function that describes the cost per watt of electricity after time t , in years, where t is the number of years since 2009.
b) Estimate the cost per watt of electricity in 2015 and in 2018.
c) At this decay rate, in which year will the average cost per watt be \$1.85?

14. **Lamborghini 350 GT.** The market value of the 1964–1965 Lamborghini 350 GT has had a recent upswing. In a decade, the car’s value increased from \$66,000 in 1999 to \$220,000 in 2009 (*Source*: “1964–1965 Lamborghini 350 GT,” by David LaChance, *Hemmings Motor News*, July, 2010, p. 28).



Assuming that the value V_0 of the car has grown exponentially:

- Find the value of k , and determine the exponential growth function, assuming $V_0 = 66,000$ and t is the number of years since 1999.
 - Estimate the value of the car in 2011.
 - After how long will the value of the car be \$300,000, assuming there is no change in the growth rate?
15. **Norman Rockwell Painting.** *Breaking Home Ties*, painted by Norman Rockwell, appeared on the cover of the *Saturday Evening Post* in 1954. In 1960, the original sold for only \$900; in 2006, this painting was sold at Sotheby’s auction house for \$15.4 million (*Source*: *Associated Press, Indianapolis Star*, December 2, 2006, p. B5).



Assuming that the value R_0 of the painting has grown exponentially:

- Find the value of k , and determine the exponential growth function, assuming $R_0 = 900$ and t is the number of years since 1960.
 - Estimate the value of the painting in 2010.
 - What is the doubling time for the value of the painting?
 - After how long will the value of the painting be \$25 million, assuming there is no change in the growth rate?
16. **T206 Wagner Baseball Card.** In 1909, the Pittsburgh Pirates shortstop Honus Wagner forced the American Tobacco Company to withdraw his baseball card that was packaged with cigarettes. Fewer than 60 of the Wagner cards still exist. In 1971, a Wagner card sold for \$1000; and in September 2007, a card in near-mint condition was purchased for a record \$2.8 million (*Source*: *USA Today*, 9/6/07; Kathy Willens/AP).



Assuming that the value W_0 of the baseball card has grown exponentially:

- Find the value of k , and determine the exponential growth function, assuming $W_0 = 1000$ and t is the number of years since 1971.
- Estimate the value of the Wagner card in 2011.
- What is the doubling time for the value of the card?
- After how long will the value of the Wagner card be \$3 million, assuming there is no change in the growth rate?

17. **Spread of an Epidemic.** In a town whose population is 3500, a disease creates an epidemic. The number of people N infected t days after the disease has begun is given by the function

$$N(t) = \frac{3500}{1 + 19.9e^{-0.6t}}$$

- How many are initially infected with the disease ($t = 0$)?
 - Find the number infected after 2 days, 5 days, 8 days, 12 days, and 16 days.
 - Using this model, can you say whether all 3500 people will ever be infected? Explain.
18. **Limited Population Growth in a Lake.** A lake is stocked with 640 fish of a new variety. The size of the lake, the availability of food, and the number of other fish restrict the growth of that type of fish in the lake to a limiting value of 3040. The population of fish in the lake after time t , in months, is given by the function

$$P(t) = \frac{3040}{1 + 3.75e^{-0.32t}}$$

Find the population after 0, 1, 5, 10, 15, and 20 months.

Newton's Law of Cooling. Suppose that a body with temperature T_1 is placed in surroundings with temperature T_0 different from that of T_1 . The body will either cool or warm to temperature $T(t)$ after time t , in minutes, where

$$T(t) = T_0 + (T_1 - T_0)e^{-kt}$$

Use this law in Exercises 19–22.

- A cup of coffee with temperature 105°F is placed in a freezer with temperature 0°F . After 5 min, the temperature of the coffee is 70°F . What will its temperature be after 10 min?
- A dish of lasagna baked at 375°F is taken out of the oven at 11:15 A.M. into a kitchen that is 72°F . After 3 min, the temperature of the lasagna is 365°F . What will the temperature of the lasagna be at 11:30 A.M.?
- A chilled jello salad that has a temperature of 43°F is taken from the refrigerator and placed on the dining room table in a room that is 68°F . After 12 min, the temperature of the salad is 55°F . What will the temperature of the salad be after 20 min?
- When Was the Murder Committed?** The police discover the body of a murder victim. Critical to solving the crime is determining when the murder was committed. The coroner arrives at the murder scene at 12:00 P.M. She immediately takes the temperature of the body and finds it to be 94.6°F . She then takes the temperature 1 hr later and finds it to be 93.4°F . The temperature of the room is 70°F . When was the murder committed?

Skill Maintenance

In Exercises 23–28, choose the correct name of the principle or the rule from the given choices.

principle of zero products
multiplication principle for equations
product rule
addition principle for inequalities
power rule
multiplication principle for inequalities
principle of square roots
quotient rule

- For any real numbers a , b , and c : If $a < b$ and $c > 0$ are true, then $ac < bc$ is true. If $a < b$ and $c < 0$ are true, then $ac > bc$ is true.

- For any positive numbers M and N and any logarithmic base a , $\log_a MN = \log_a M + \log_a N$.

- If $ab = 0$ is true, then $a = 0$ or $b = 0$, and if $a = 0$ or $b = 0$, then $ab = 0$.

- If $x^2 = k$, then $x = \sqrt{k}$ or $x = -\sqrt{k}$.

- For any positive number M , any logarithmic base a , and any real number p , $\log_a M^p = p \log_a M$.

- For any real numbers a , b , and c : If $a = b$ is true, then $ac = bc$ is true.



Synthesis

29. **Supply and Demand.** The supply function and the demand function for the sale of a certain type of DVD player are given by

$$S(p) = 150e^{0.004p} \quad \text{and} \quad D(p) = 480e^{-0.003p},$$

where $S(p)$ is the number of DVD players that the company is willing to sell at price p and $D(p)$ is the quantity that the public is willing to buy at price p . Find p such that $D(p) = S(p)$. This is called the **equilibrium price**.

30. **Carbon Dating.** Recently, while digging in Chaco Canyon, New Mexico, archaeologists found corn pollen that was 4000 years old (*Source: American Anthropologist*). This was evidence that Native Americans had been cultivating crops in the Southwest centuries earlier than scientists had thought. What percent of the carbon-14 had been lost from the pollen?



31. **Present Value.** Following the birth of a child, a parent wants to make an initial investment P_0 that will grow to \$50,000 for the child's education at

age 18. Interest is compounded continuously at 7%. What should the initial investment be? Such an amount is called the **present value** of \$50,000 due 18 years from now.

32. **Present Value.**

a) Solve $P = P_0e^{kt}$ for P_0 .

b) Referring to Exercise 31, find the present value of \$50,000 due 18 years from now at interest rate 6.4%, compounded continuously.

33. **Electricity.** The formula

$$i = \frac{V}{R} [1 - e^{-(R/L)t}]$$

occurs in the theory of electricity. Solve for t .

34. **The Beer-Lambert Law.** A beam of light enters a medium such as water or smog with initial intensity I_0 . Its intensity decreases depending on the thickness (or concentration) of the medium. The intensity I at a depth (or concentration) of x units is given by

$$I = I_0e^{-\mu x}.$$

The constant μ (the Greek letter "mu") is called the **coefficient of absorption**, and it varies with the medium. For sea water, $\mu = 1.4$.

- a) What percentage of light intensity I_0 remains in sea water at a depth of 1 m? 3 m? 5 m? 50 m?
- b) Plant life cannot exist below 10 m. What percentage of I_0 remains at 10 m?
35. Given that $y = ae^x$, take the natural logarithm on both sides. Let $Y = \ln y$. Consider Y as a function of x . What kind of function is Y ?
36. Given that $y = ax^b$, take the natural logarithm on both sides. Let $Y = \ln y$ and $X = \ln x$. Consider Y as a function of X . What kind of function is Y ?

Chapter 5 Summary and Review

STUDY GUIDE

KEY TERMS AND CONCEPTS

EXAMPLES

SECTION 5.1: INVERSE FUNCTIONS

Inverse Relation

If a relation is defined by an equation, interchanging the variables produces an equation of the inverse relation.

One-to-One Functions

A function f is one-to-one if different inputs have different outputs—that is,

$$\text{if } a \neq b, \text{ then } f(a) \neq f(b).$$

Or a function f is one-to-one if when the outputs are the same, the inputs are the same—that is,

$$\text{if } f(a) = f(b), \text{ then } a = b.$$

Horizontal-Line Test

If it is possible for a horizontal line to intersect the graph of a function more than once, then the function is *not* one-to-one and its inverse is *not* a function.

One-to-One Functions and Inverses

- If a function f is one-to-one, then its inverse f^{-1} is a function.
- The domain of a one-to-one function f is the range of the inverse f^{-1} .
- The range of a one-to-one function f is the domain of the inverse f^{-1} .
- A function that is increasing over its entire domain or is decreasing over its entire domain is a one-to-one function.

Obtaining a Formula for an Inverse

If a function f is one-to-one, a formula for its inverse can generally be found as follows:

1. Replace $f(x)$ with y .
2. Interchange x and y .
3. Solve for y .
4. Replace y with $f^{-1}(x)$.

The -1 in f^{-1} is *not* an exponent. The graph of f^{-1} is a reflection of the graph of f across the line $y = x$.

Given $y = -5x + 7$, find an equation of the inverse relation.

$$\begin{array}{ll} y = -5x + 7 & \text{Relation} \\ \downarrow & \downarrow \\ x = -5y + 7 & \text{Inverse relation} \end{array}$$

Prove that $f(x) = 16 - 3x$ is one-to-one.

Show that if $f(a) = f(b)$, then $a = b$. Assume $f(a) = f(b)$. Since $f(a) = 16 - 3a$ and $f(b) = 16 - 3b$,

$$\begin{aligned} 16 - 3a &= 16 - 3b \\ -3a &= -3b \\ a &= b. \end{aligned}$$

Thus, if $f(a) = f(b)$, then $a = b$ and f is one-to-one.

Using its graph, determine whether each function is one-to-one.

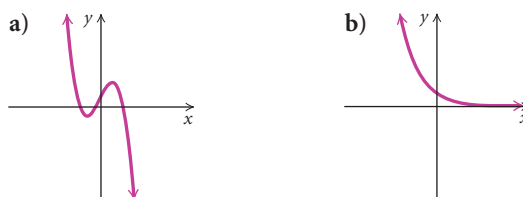

- a) There are many horizontal lines that intersect the graph more than once. Thus the function is *not* one-to-one and its inverse is *not* a function.
- b) No horizontal line intersects the graph more than once. Thus the function is one-to-one and its inverse is a function.

Given the one-to-one function $f(x) = 2 - x^3$, find a formula for its inverse. Then graph the function and its inverse on the same set of axes.

- $$f(x) = 2 - x^3$$
1. $y = 2 - x^3$
 2. $x = 2 - y^3$
 3. Solve for y :

$$y^3 = 2 - x \quad \text{Adding } y^3 \text{ and subtracting } x$$

$$y = \sqrt[3]{2 - x}$$
 4. $f^{-1}(x) = \sqrt[3]{2 - x}$

(Continued)

$$f(x) = 2 - x^3 \text{ and } f^{-1}(x) = \sqrt[3]{2 - x}$$

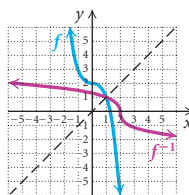

If a function f is one-to-one, then f^{-1} is the unique function such that each of the following holds:

$$(f^{-1} \circ f)(x) = f^{-1}(f(x)) = x,$$

for each x in the domain of f , and

$$(f \circ f^{-1})(x) = f(f^{-1}(x)) = x,$$

for each x in the domain of f^{-1} .

Given $f(x) = \frac{3+x}{x}$, use composition of functions to show

$$\text{that } f^{-1}(x) = \frac{3}{x-1}.$$

$$\begin{aligned} (f^{-1} \circ f)(x) &= f^{-1}(f(x)) \\ &= f^{-1}\left(\frac{3+x}{x}\right) = \frac{3}{\frac{3+x}{x} - 1} \\ &= \frac{3}{\frac{3+x-x}{x}} = \frac{3}{\frac{3}{x}} = 3 \cdot \frac{x}{3} = x; \end{aligned}$$

$$\begin{aligned} (f \circ f^{-1})(x) &= f(f^{-1}(x)) = f\left(\frac{3}{x-1}\right) \\ &= \frac{3 + \frac{3}{x-1}}{\frac{3}{x-1}} = \frac{3(x-1) + 3}{x-1} \cdot \frac{x-1}{3} \\ &= \frac{3x - 3 + 3}{3} = \frac{3x}{3} = x \end{aligned}$$

SECTION 5.2: EXPONENTIAL FUNCTIONS AND GRAPHS

Exponential Function

$$y = a^x, \text{ or } f(x) = a^x, \quad a > 0, a \neq 1$$

Continuous

One-to-one

Domain: $(-\infty, \infty)$

Range: $(0, \infty)$

Increasing if $a > 1$

Decreasing if $0 < a < 1$

Horizontal asymptote is x -axis

y -intercept: $(0, 1)$

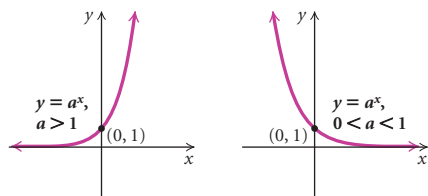

Graph: $f(x) = 2^x$, $g(x) = 2^{-x}$, $h(x) = 2^{x-1}$, and $t(x) = 2^x - 1$.

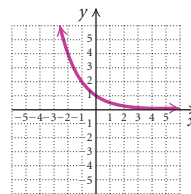
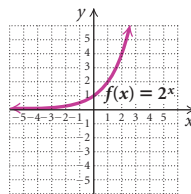

$$g(x) = \left(\frac{1}{2}\right)^x = 2^{-x}$$

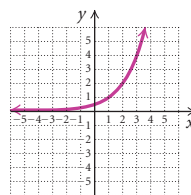

$$h(x) = 2^{x-1}$$

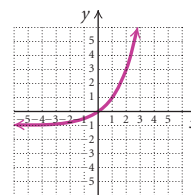

$$t(x) = 2^x - 1$$

Compound Interest

The amount of money A to which a principal P will grow after t years at interest rate r (in decimal form), compounded n times per year, is given by the formula

$$A = P \left(1 + \frac{r}{n} \right)^{nt}$$

Suppose that \$5000 is invested at 3.5% interest, compounded quarterly. Find the money in the account after 3 years.

$$\begin{aligned} A &= P \left(1 + \frac{r}{n} \right)^{nt} = 5000 \left(1 + \frac{0.035}{4} \right)^{4 \cdot 3} \\ &= \$5551.02 \end{aligned}$$

The Number e

$$e = 2.7182818284 \dots$$

Find each of the following, to four decimal places, using a calculator.

$$e^{-3} = 0.0498;$$

$$e^{4.5} = 90.0171$$

Graph: $f(x) = e^x$ and $g(x) = e^{-x+2} - 4$.

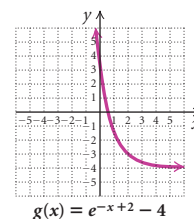
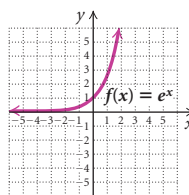

SECTION 5.3: LOGARITHMIC FUNCTIONS AND GRAPHS

Logarithmic Function

$$y = \log_a x, \quad x > 0, a > 0, a \neq 1$$

Continuous

One-to-one

Domain: $(0, \infty)$

Range: $(-\infty, \infty)$

Increasing if $a > 1$

Vertical asymptote is y -axis

x -intercept: $(1, 0)$

The inverse of an exponential function $f(x) = a^x$ is given by $f^{-1}(x) = \log_a x$.

Graph: $f(x) = \log_2 x$ and $g(x) = \ln(x - 1) + 2$.

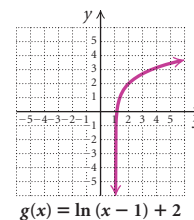
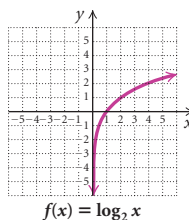

A logarithm is an exponent:

$$\log_a x = y \iff x = a^y.$$

Convert each logarithmic equation to an exponential equation.

$$\log_4 \frac{1}{16} = -2 \iff 4^{-2} = \frac{1}{16};$$

$$\ln R = 3 \iff e^3 = R$$

Convert each exponential equation to a logarithmic equation.

$$e^{-5} = 0.0067 \iff \ln 0.0067 = -5;$$

$$7^2 = 49 \iff \log_7 49 = 2$$

$\log x$ means $\log_{10} x$ **Common logarithms**

$\ln x$ means $\log_e x$ **Natural logarithms**

For any logarithm base a ,

$$\log_a 1 = 0 \quad \text{and} \quad \log_a a = 1.$$

For the logarithm base e ,

$$\ln 1 = 0 \quad \text{and} \quad \ln e = 1.$$

The Change-of-Base Formula

For any logarithmic bases a and b , and any positive number M ,

$$\log_b M = \frac{\log_a M}{\log_a b}.$$

Earthquake Magnitude

The magnitude R , measured on the Richter scale, of an earthquake of intensity I is defined as

$$R = \log \frac{I}{I_0},$$

where I_0 is a minimum intensity used for comparison.

Find each of the following without using a calculator.

$$\log 100 = 2; \quad \log 10^{-5} = -5;$$

$$\ln 1 = 0; \quad \log_9 9 = 1;$$

$$\ln \sqrt[3]{e} = \frac{1}{3}; \quad \log_2 64 = 6;$$

$$\log_8 1 = 0; \quad \ln e = 1$$

Find each of the following using a calculator and rounding to four decimal places.

$$\ln 223 = 5.4072; \quad \log \frac{2}{9} = -0.6532;$$

$$\log(-8) \text{ Does not exist}; \quad \ln 0.06 = -2.8134$$

Find $\log_3 11$ using common logarithms:

$$\log_3 11 = \frac{\log 11}{\log 3} \approx 2.1827.$$

Find $\log_3 11$ using natural logarithms:

$$\log_3 11 = \frac{\ln 11}{\ln 3} \approx 2.1827.$$

What is the magnitude on the Richter scale of an earthquake of intensity $10^{6.8} \cdot I_0$?

$$R = \log \frac{I}{I_0} = \log \frac{10^{6.8} \cdot I_0}{I_0} = \log 10^{6.8} = 6.8$$

SECTION 5.4: PROPERTIES OF LOGARITHMIC FUNCTIONS

The Product Rule

For any positive numbers M and N , and any logarithmic base a ,

$$\log_a MN = \log_a M + \log_a N.$$

The Power Rule

For any positive number M , any logarithmic base a , and any real number p ,

$$\log_a M^p = p \log_a M.$$

The Quotient Rule

For any positive numbers M and N , and any logarithmic base a ,

$$\log_a \frac{M}{N} = \log_a M - \log_a N.$$

Express $\log_c \sqrt{\frac{c^2 r}{b^3}}$ in terms of sums and differences of logarithms.

$$\begin{aligned} \log_c \sqrt{\frac{c^2 r}{b^3}} &= \log_c \left(\frac{c^2 r}{b^3} \right)^{1/2} \\ &= \frac{1}{2} \log_c \left(\frac{c^2 r}{b^3} \right) \\ &= \frac{1}{2} (\log_c c^2 r - \log_c b^3) \\ &= \frac{1}{2} (\log_c c^2 + \log_c r - 3 \log_c b) \\ &= \frac{1}{2} (2 + \log_c r - 3 \log_c b) \\ &= 1 + \frac{1}{2} \log_c r - \frac{3}{2} \log_c b \end{aligned}$$

Express $\ln(3x^2 + 5x - 2) - \ln(x + 2)$ as a single logarithm.

$$\begin{aligned} \ln(3x^2 + 5x - 2) - \ln(x + 2) &= \ln \frac{3x^2 + 5x - 2}{x + 2} \\ &= \ln \frac{(3x - 1)(x + 2)}{x + 2} \\ &= \ln(3x - 1) \end{aligned}$$

Given $\log_a 7 \approx 0.8451$ and $\log_a 5 \approx 0.6990$, find $\log_a \frac{1}{7}$ and $\log_a 35$.

$$\log_a \frac{1}{7} = \log_a 1 - \log_a 7 \approx 0 - 0.8451 \approx -0.8451;$$

$$\begin{aligned}\log_a 35 &= \log_a (7 \cdot 5) = \log_a 7 + \log_a 5 \\ &\approx 0.8451 + 0.6990 \\ &\approx 1.5441\end{aligned}$$

For any base a and any real number x ,

$$\log_a a^x = x.$$

For any base a and any positive real number x ,

$$a^{\log_a x} = x.$$

Simplify each of the following.

$$8^{\log_8 k} = k; \quad \log 10^{43} = 43;$$

$$\log_a a^4 = 4; \quad e^{\ln 2} = 2$$

SECTION 5.5: SOLVING EXPONENTIAL EQUATIONS AND LOGARITHMIC EQUATIONS

The Base-Exponent Property

For any $a > 0$, $a \neq 1$,

$$a^x = a^y \iff x = y.$$

Solve: $3^{2x-3} = 81$.

$$3^{2x-3} = 3^4 \quad 81 = 3^4$$

$$2x - 3 = 4$$

$$2x = 7$$

$$x = \frac{7}{2}$$

The solution is $\frac{7}{2}$.

The Property of Logarithmic Equality

For any $M > 0$, $N > 0$, $a > 0$, and $a \neq 1$,

$$\log_a M = \log_a N \iff M = N.$$

Solve: $6^{x-2} = 2^{-3x}$.

$$\log 6^{x-2} = \log 2^{-3x}$$

$$(x - 2)\log 6 = -3x \log 2$$

$$x \log 6 - 2 \log 6 = -3x \log 2$$

$$x \log 6 + 3x \log 2 = 2 \log 6$$

$$x(\log 6 + 3 \log 2) = 2 \log 6$$

$$x = \frac{2 \log 6}{\log 6 + 3 \log 2}$$

$$x \approx 0.9257$$

Solve: $\log_3 (x - 2) + \log_3 x = 1$.

$$\log_3 [x(x - 2)] = 1$$

$$x(x - 2) = 3^1$$

$$x^2 - 2x - 3 = 0$$

$$(x - 3)(x + 1) = 0$$

$$x - 3 = 0 \quad \text{or} \quad x + 1 = 0$$

$$x = 3 \quad \text{or} \quad x = -1$$

The number -1 is not a solution because negative numbers do not have real-number logarithms. The value 3 checks and is the solution.

Solve: $\ln(x + 10) - \ln(x + 4) = \ln x$.

$$\ln \frac{x + 10}{x + 4} = \ln x$$

$$\frac{x + 10}{x + 4} = x$$

$$x + 10 = x(x + 4)$$

$$x + 10 = x^2 + 4x$$

$$0 = x^2 + 3x - 10$$

$$0 = (x + 5)(x - 2)$$

$$x + 5 = 0 \quad \text{or} \quad x - 2 = 0$$

$$x = -5 \quad \text{or} \quad x = 2$$

The number -5 is not a solution because $-5 + 4 = -1$ and $\ln(-1)$ is not a real number. The value 2 checks and is the solution.

SECTION 5.6: APPLICATIONS AND MODELS: GROWTH AND DECAY; COMPOUND INTEREST

Exponential Growth Model

$$P(t) = P_0 e^{kt}, \quad k > 0$$

Doubling Time

$$kT = \ln 2, \quad \text{or} \quad k = \frac{\ln 2}{T}, \quad \text{or} \quad T = \frac{\ln 2}{k}$$

In July 2010, the population of the United States was 310.2 million, and the exponential growth rate was 0.97% per year (*Sources: CIA World Factbook, The New York Times Almanac 2010*). After how long will the population be double what it was in 2010? Estimate the population in 2015.

With a population growth rate of 0.97%, or 0.0097, the doubling time T is

$$T = \frac{\ln 2}{k} = \frac{\ln 2}{0.0097} \approx 71.$$

The population of the United States will be double what it was in 2010 in about 71 years.

The exponential growth function is

$$P(t) = 310.2e^{0.0097t}$$

where t is the number of years after 2010 and $P(t)$ is in millions.

Since in 2015, $t = 5$, substitute 5 for t :

$$P(5) = 310.2e^{0.0097 \cdot 5} = 310.2e^{0.0485} \approx 325.6.$$

The population will be about 325.6 million, or 325,600,000, in 2015.

Interest Compounded Continuously

$$P(t) = P_0 e^{kt}, \quad k > 0$$

Suppose that \$20,000 is invested at interest rate k , compounded continuously, and grows to \$23,236.68 in 3 years. What is the interest rate? What will the balance be in 8 years?

The exponential growth function is of the form $P(t) = 20,000e^{kt}$. Given that $P(3) = \$23,236.68$, substituting 3 for t and 23,236.68 for $P(t)$ gives

$$23,236.68 = 20,000e^{k(3)}$$

to get $k \approx 0.05$, or 5%.

Then substitute 0.05 for k and 8 for t and determine $P(8)$:

$$P(8) = 20,000e^{0.05(8)} = 20,000e^{0.4} \approx \$29,836.49.$$

Exponential Decay Model

$$P(t) = P_0 e^{-kt}, \quad k > 0$$

Half-Life

$$kT = \ln 2, \quad \text{or} \quad k = \frac{\ln 2}{T}, \quad \text{or} \quad T = \frac{\ln 2}{k}$$

Archaeologists discovered an animal bone that had lost 65.2% of its carbon-14 at the time it was found. How old was the bone?

The decay rate for carbon-14 is 0.012%, or 0.00012. If the bone has lost 65.2% of its carbon-14 from an initial amount P_0 , then 34.8% P_0 is the amount present. Substitute 34.8% P_0 for $P(t)$ and solve:

$$34.8\% P_0 = P_0 e^{-0.00012t}$$

$$0.348 = e^{-0.00012t}$$

$$\ln 0.348 = -0.00012t$$

$$\frac{\ln 0.348}{-0.00012} = t$$

$$8796 \approx t.$$

The bone was about 8796 years old when it was found.

REVIEW EXERCISES

Determine whether the statement is true or false.

- The domain of a one-to-one function f is the range of the inverse f^{-1} . [5.1]
- The x -intercept of $f(x) = \log x$ is $(0, 1)$. [5.3]
- The graph of f^{-1} is a reflection of the graph of f across $y = 0$. [5.1]
- If it is not possible for a horizontal line to intersect the graph of a function more than once, then the function is one-to-one and its inverse is a function. [5.1]
- The range of all exponential functions is $[0, \infty)$. [5.2]
- The horizontal asymptote of $y = 2^x$ is $y = 0$. [5.2]
- Find the inverse of the relation $\{(1.3, -2.7), (8, -3), (-5, 3), (6, -3), (7, -5)\}$. [5.1]
- Find an equation of the inverse relation. [5.1]
 - $y = -2x + 3$
 - $y = 3x^2 + 2x - 1$
 - $0.8x^3 - 5.4y^2 = 3x$

Graph the function and determine whether the function is one-to-one using the horizontal-line test. [5.1]

- $f(x) = -|x| + 3$
- $f(x) = x^2 + 1$
- $f(x) = 2x - \frac{3}{4}$
- $f(x) = -\frac{6}{x+1}$

In Exercises 13–18, given the function:

- Sketch the graph and determine whether the function is one-to-one. [5.1], [5.3]
- If it is one-to-one, find a formula for the inverse. [5.1], [5.3]

$$13. f(x) = 2 - 3x \qquad 14. f(x) = \frac{x+2}{x-1}$$

$$15. f(x) = \sqrt{x-6} \qquad 16. f(x) = x^3 - 8$$

$$17. f(x) = 3x^2 + 2x - 1 \qquad 18. f(x) = e^x$$

For the function f , use composition of functions to show that f^{-1} is as given. [5.1]

$$19. f(x) = 6x - 5, \quad f^{-1}(x) = \frac{x+5}{6}$$

$$20. f(x) = \frac{x+1}{x}, \quad f^{-1}(x) = \frac{1}{x-1}$$

Find the inverse of the given one-to-one function f . Give the domain and the range of f and of f^{-1} and then graph both f and f^{-1} on the same set of axes. [5.1]

$$21. f(x) = 2 - 5x \qquad 22. f(x) = \frac{x-3}{x+2}$$

$$23. \text{ Find } f(f^{-1}(657)): f(x) = \frac{4x^5 - 16x^{37}}{119x}, \quad x > 1. \quad [5.1]$$

$$24. \text{ Find } f(f^{-1}(a)): f(x) = \sqrt[3]{3x-4}. \quad [5.1]$$

Graph the function.

25. $f(x) = \left(\frac{1}{3}\right)^x$ [5.2]

27. $f(x) = -e^{-x}$ [5.2]

29. $f(x) = \frac{1}{2} \ln x$ [5.3]

26. $f(x) = 1 + e^x$ [5.2]

28. $f(x) = \log_2 x$ [5.3]

30. $f(x) = \log x - 2$ [5.3]

In Exercises 31–36, match the equation with one of the figures (a)–(f), which follow.

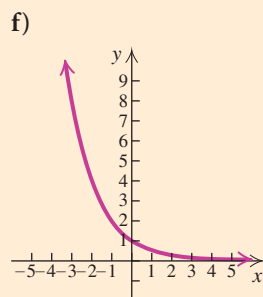
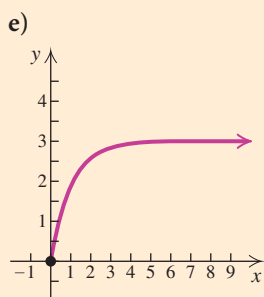
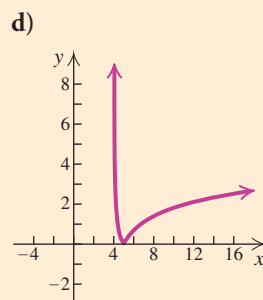
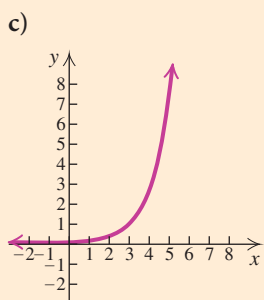
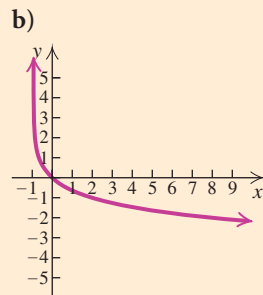
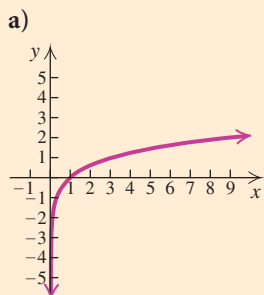

31. $f(x) = e^{x-3}$ [5.2]

33. $y = -\log_3(x+1)$ [5.3]

35. $f(x) = 3(1 - e^{-x}), x \geq 0$ [5.2]

36. $f(x) = |\ln(x-4)|$ [5.3]

32. $f(x) = \log_3 x$ [5.3]

34. $y = \left(\frac{1}{2}\right)^x$ [5.2]

Find each of the following. Do not use a calculator. [5.3]

37. $\log_5 125$

39. $\ln e$

41. $\log 10^{1/4}$

38. $\log 100,000$

40. $\ln 1$

42. $\log_3 \sqrt{3}$

43. $\log 1$

45. $\log_2 \sqrt[3]{2}$

Convert to an exponential equation. [5.3]

47. $\log_4 x = 2$

Convert to a logarithmic equation. [5.3]

49. $4^{-3} = \frac{1}{64}$

Find each of the following using a calculator. Round to four decimal places. [5.3]

51. $\log 11$

53. $\ln 3$

55. $\log(-3)$

Find the logarithm using the change-of-base formula. [5.3]

57. $\log_5 24$

Express as a single logarithm and, if possible, simplify. [5.4]

59. $3 \log_b x - 4 \log_b y + \frac{1}{2} \log_b z$

60. $\ln(x^3 - 8) - \ln(x^2 + 2x + 4) + \ln(x + 2)$

Express in terms of sums and differences of logarithms. [5.4]

61. $\ln \sqrt[4]{wr^2}$

62. $\log \sqrt[3]{\frac{M^2}{N}}$

Given that $\log_a 2 = 0.301$, $\log_a 5 = 0.699$, and $\log_a 6 = 0.778$, find each of the following. [5.4]

63. $\log_a 3$

65. $\log_a \frac{1}{5}$

Simplify. [5.4]

67. $\ln e^{-5k}$

Solve. [5.5]

69. $\log_4 x = 2$

71. $e^x = 80$

73. $\log_{16} 4 = x$

75. $\log_2 x + \log_2(x-2) = 3$

76. $\log(x^2 - 1) - \log(x - 1) = 1$

77. $\log x^2 = \log x$

78. $e^{-x} = 0.02$

44. $\log 10$

46. $\log 0.01$

48. $\log_a Q = k$

50. $e^x = 80$

52. $\log 0.234$

54. $\ln 0.027$

56. $\ln 0$

58. $\log_8 3$

62. $\log \sqrt[3]{\frac{M^2}{N}}$

60. $\ln(x^3 - 8) - \ln(x^2 + 2x + 4) + \ln(x + 2)$

62. $\log \sqrt[3]{\frac{M^2}{N}}$

64. $\log_a 50$

66. $\log_a \sqrt[3]{5}$

68. $\log_5 5^{-6t}$

70. $3^{1-x} = 9^{2x}$

72. $4^{2x-1} - 3 = 61$

74. $\log_x 125 = 3$

79. **Saving for College.** Following the birth of twins, the grandparents deposit \$16,000 in a college trust fund that earns 4.2% interest, compounded quarterly.
- Find a function for the amount in the account after t years. [5.2]
 - Find the amount in the account at $t = 0, 6, 12,$ and 18 years. [5.2]
80. **Personal Breathalyzer Sales.** In recent years, the sales of personal breathalyzers have been increasing exponentially. The total amount of sales, in millions of dollars, is estimated by the function
- $$B(t) = 27.9(1.3299)^t,$$
- where t is the number of years since 2005 (*Source:* WinterGreen Research). Find the sales in 2008. Then use the function to estimate the sales in 2014. [5.2]
81. How long will it take an investment to double if it is invested at 8.6%, compounded continuously? [5.6]
82. The population of Murrayville doubled in 30 years. What was the exponential growth rate? [5.6]
83. How old is a skeleton that has lost 27% of its carbon-14? [5.6]
84. The hydrogen ion concentration of milk is 2.3×10^{-6} . What is the pH? (See Exercise 98 in Exercise Set 5.3.) [5.3]
85. **Earthquake Magnitude.** The earthquake in Kashgar, China, on February 25, 2003, had an intensity of $10^{6.3} \cdot I_0$ (*Source:* U.S. Geological Survey). What is the magnitude on the Richter scale? [5.3]
86. What is the loudness, in decibels, of a sound whose intensity is $1000I_0$? (See Exercise 101 in Exercise Set 5.3.) [5.3]
87. **Walking Speed.** The average walking speed w , in feet per second, of a person living in a city of population P , in thousands, is given by the function
- $$w(P) = 0.37 \ln P + 0.05.$$
- The population of Wichita, Kansas, is 353,823. Find the average walking speed. [5.3]
 - A city's population has an average walking speed of 3.4 ft/sec. Find the population. [5.6]
88. **Social Security Distributions.** Cash Social Security distributions were \$35 million, or \$0.035 billion, in 1940. This amount has increased exponentially to \$492 billion in 2004. (*Source:* Social Security Administration) Assuming that the exponential growth model applies:
- Find the exponential growth rate k . [5.6]
 - Find the exponential growth function. [5.6]
 - Estimate the total cash distributions in 1965, in 1995, and in 2015. [5.6]
 - In what year will the cash benefits reach \$1 trillion? [5.6]
89. **The Population of Panama.** The population of Panama was 3.039 million in 2005, and the exponential growth rate was 1.3% per year (*Source:* U.S. Census Bureau, World Population Profile).
- Find the exponential growth function. [5.6]
 - What will the population be in 2009? in 2015? [5.6]
 - When will the population be 10 million? [5.6]
 - What is the doubling time? [5.6]



90. Which of the following is the horizontal asymptote of the graph of $f(x) = e^{x-3} + 2$? [5.2]

- A. $y = -2$ B. $y = -3$
 C. $y = 3$ D. $y = 2$

91. Which of the following is the domain of the logarithmic function $f(x) = \log(2x - 3)$? [5.3]

- A. $(\frac{3}{2}, \infty)$ B. $(-\infty, \frac{3}{2})$
 C. $(3, \infty)$ D. $(-\infty, \infty)$

92. The graph of $f(x) = 2^{x-2}$ is which of the following? [5.2]

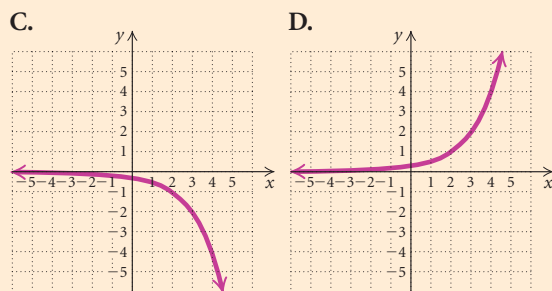
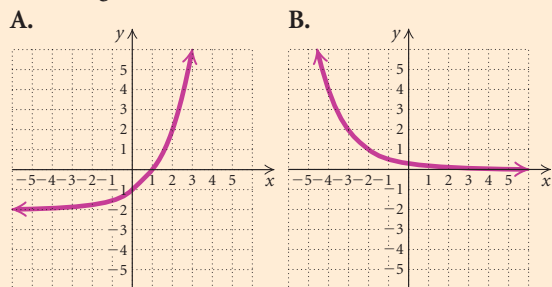

93. The graph of $f(x) = \log_2 x$ is which of the following? [5.3]

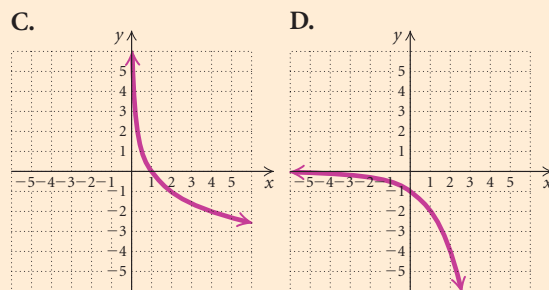
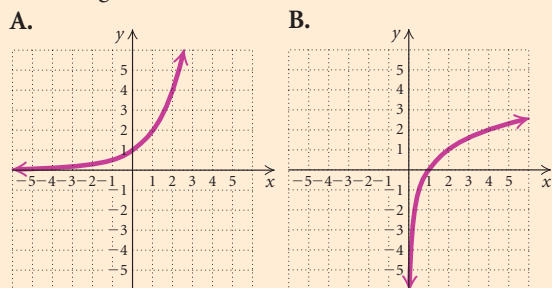

Synthesis

Solve. [5.5]

94. $|\log_4 x| = 3$
 95. $\log x = \ln x$
 96. $5^{\sqrt{x}} = 625$
 97. Find the domain: $f(x) = \log_3(\ln x)$. [5.3]

Collaborative Discussion and Writing

98. Explain how the graph of $f(x) = \ln x$ can be used to obtain the graph of $g(x) = e^{x-2}$. [5.3]
99. **Atmospheric Pressure.** Atmospheric pressure P at an altitude a is given by
- $$P = P_0 e^{-0.00005a},$$
- where P_0 is the pressure at sea level, approximately 14.7 lb/in^2 (pounds per square inch). Explain how a barometer, or some device for measuring atmospheric pressure, can be used to find the height of a skyscraper. [5.6]

100. Explain the errors, if any, in the following: [5.4]
 $\log_a ab^3 = (\log_a a)(\log_a b^3) = 3 \log_a b.$
101. Describe the difference between $f^{-1}(x)$ and $[f(x)]^{-1}$. [5.1]

Chapter 5 Test

1. Find the inverse of the relation

$$\{(-2, 5), (4, 3), (0, -1), (-6, -3)\}.$$

Determine whether the function is one-to-one. Answer yes or no.

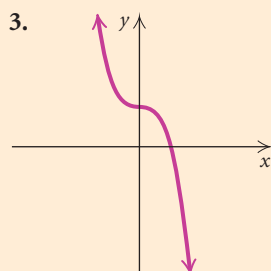
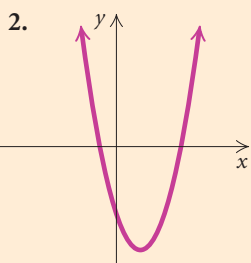

In Exercises 4–7, given the function:

- a) Sketch the graph and determine whether the function is one-to-one.

- b) If it is one-to-one, find a formula for the inverse.

4. $f(x) = x^3 + 1$

5. $f(x) = 1 - x$

6. $f(x) = \frac{x}{2 - x}$

7. $f(x) = x^2 + x - 3$

8. Use composition of functions to show that f^{-1} is as given:

$$f(x) = -4x + 3, \quad f^{-1}(x) = \frac{3 - x}{4}.$$

9. Find the inverse of the one-to-one function

$$f(x) = \frac{1}{x - 4}.$$

Give the domain and the range of f and of f^{-1} and then graph both f and f^{-1} on the same set of axes.

Graph the function.

10. $f(x) = 4^{-x}$

11. $f(x) = \log x$

12. $f(x) = e^x - 3$

13. $f(x) = \ln(x + 2)$

Find each of the following. Do not use a calculator.

14. $\log 0.00001$

15. $\ln e$

16. $\ln 1$

17. $\log_4 \sqrt[5]{4}$

18. Convert to an exponential equation: $\ln x = 4$.

19. Convert to a logarithmic equation: $3^x = 5.4$.

Find each of the following using a calculator. Round to four decimal places.

20. $\ln 16$

21. $\log 0.293$

22. Find $\log_6 10$ using the change-of-base formula.

23. Express as a single logarithm:

$$2 \log_a x - \log_a y + \frac{1}{2} \log_a z.$$

24. Express $\ln \sqrt[5]{x^2 y}$ in terms of sums and differences of logarithms.

25. Given that $\log_a 2 = 0.328$ and $\log_a 8 = 0.984$, find $\log_a 4$.

26. Simplify: $\ln e^{-4t}$.

Solve.

27. $\log_{25} 5 = x$

28. $\log_3 x + \log_3 (x + 8) = 2$

29. $3^{4-x} = 27^x$

30. $e^x = 65$

31. **Earthquake Magnitude.** The earthquake in Bam, in southeast Iran, on December 26, 2003, had an intensity of $10^{6.6} \cdot I_0$ (Source: U.S. Geological Survey). What was its magnitude on the Richter scale?

32. **Growth Rate.** A country's population doubled in 45 years. What was the exponential growth rate?

33. **Compound Interest.** Suppose \$1000 is invested at interest rate k , compounded continuously, and grows to \$1144.54 in 3 years.

- a) Find the interest rate.
 b) Find the exponential growth function.
 c) Find the balance after 8 years.
 d) Find the doubling time.

34. The graph of $f(x) = 2^{x-1} + 1$ is which of the following?

A.

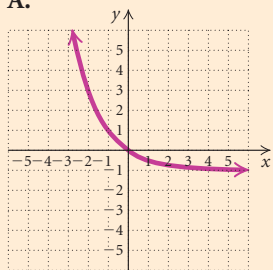

B.

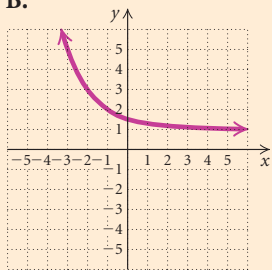

C.

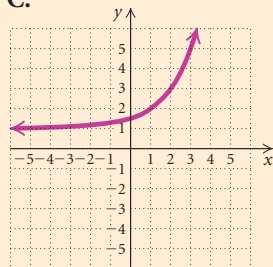

D.

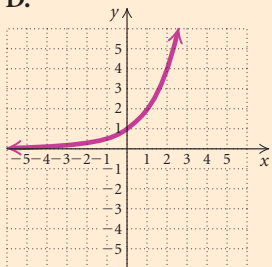

Synthesis

35. Solve: $4^{\sqrt[3]{x}} = 8$.

The Trigonometric Functions

CHAPTER

6

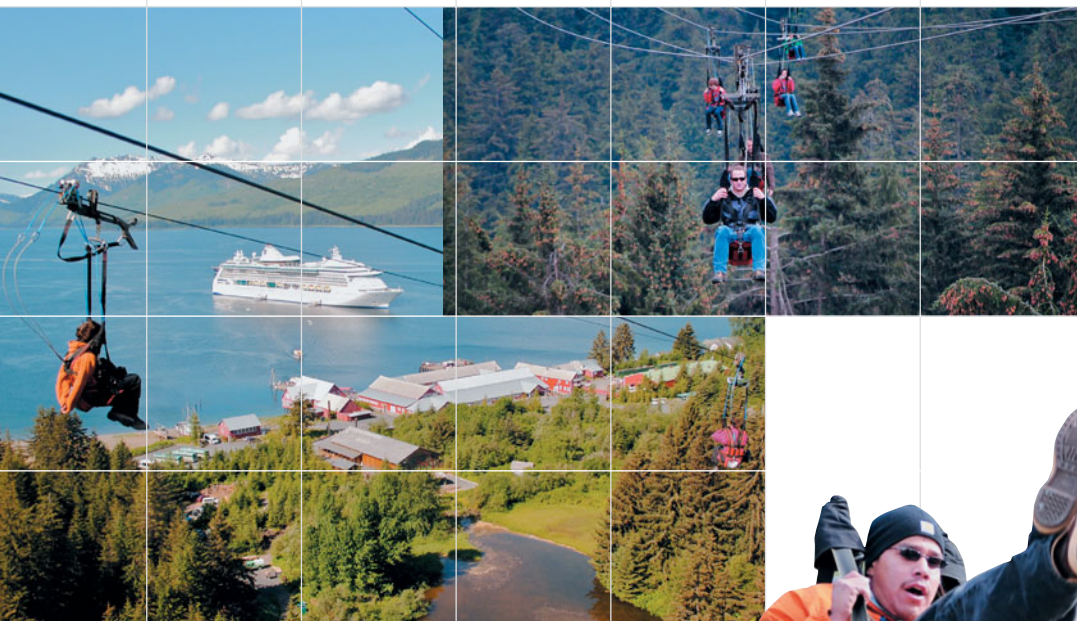

Application

The longest zip line in the world is the ZipRider® at Icy Straight Point, Alaska. Its length is 5495 ft, and it has a vertical drop of 1320 ft (*Source: www.ziprider.com*). Find its angle of depression.

This problem appears as Exercise 19 in Section 6.2.

6.1 Trigonometric Functions of Acute Angles

6.2 Applications of Right Triangles

6.3 Trigonometric Functions of Any Angle

Mid-Chapter Mixed Review

6.4 Radians, Arc Length, and Angular Speed

6.5 Circular Functions: Graphs and Properties

6.6 Graphs of Transformed Sine and Cosine Functions

Visualizing the Graph

Study Guide

Review Exercises

Chapter Test

Trigonometric Functions of Acute Angles

6.1

- ▶ Determine the six trigonometric ratios for a given acute angle of a right triangle.
- ▶ Determine the trigonometric function values of 30° , 45° , and 60° .
- ▶ Using a calculator, find function values for any acute angle, and given a function value of an acute angle, find the angle.
- ▶ Given the function values of an acute angle, find the function values of its complement.

▶ The Trigonometric Ratios

We begin our study of trigonometry by considering right triangles and acute angles measured in degrees. An **acute angle** is an angle with measure greater than 0° and less than 90° . Greek letters such as α (alpha), β (beta), γ (gamma), θ (theta), and ϕ (phi) are often used to denote an angle. Consider a right triangle with one of its acute angles labeled θ . The side opposite the right angle is called the **hypotenuse**. The other sides are referenced by their position relative to the acute angle θ . One side is opposite θ and one is adjacent to θ .

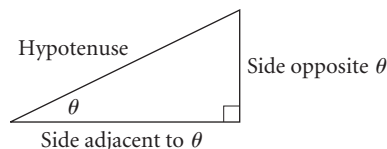

The *lengths* of the sides of the triangle are used to define the six trigonometric ratios:

sine (sin), cosecant (csc),
 cosine (cos), secant (sec),
 tangent (tan), cotangent (cot).

The **sine of θ** is the *length* of the side opposite θ divided by the *length* of the hypotenuse (see Fig. 1):

$$\sin \theta = \frac{\text{length of side opposite } \theta}{\text{length of hypotenuse}}.$$

The ratio depends on the measure of angle θ and thus is a **function** of θ . The notation $\sin \theta$ actually means $\sin(\theta)$, where \sin , or *sine*, is the name of the function.

The **cosine of θ** is the *length* of the side adjacent to θ divided by the *length* of the hypotenuse (see Fig. 2):

$$\cos \theta = \frac{\text{length of side adjacent to } \theta}{\text{length of hypotenuse}}.$$

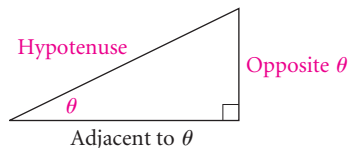

Figure 1

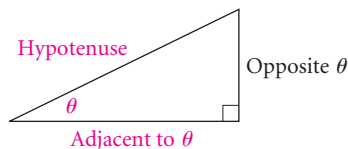
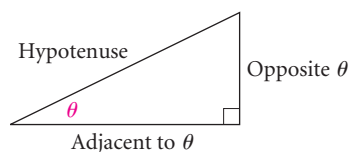

Figure 2

The six trigonometric ratios, or trigonometric functions, are defined as follows.



Trigonometric Function Values of an Acute Angle θ

Let θ be an acute angle of a right triangle. Then the six trigonometric functions of θ are as follows:

$$\begin{aligned}\sin \theta &= \frac{\text{side opposite } \theta}{\text{hypotenuse}}, & \csc \theta &= \frac{\text{hypotenuse}}{\text{side opposite } \theta}, \\ \cos \theta &= \frac{\text{side adjacent to } \theta}{\text{hypotenuse}}, & \sec \theta &= \frac{\text{hypotenuse}}{\text{side adjacent to } \theta}, \\ \tan \theta &= \frac{\text{side opposite } \theta}{\text{side adjacent to } \theta}, & \cot \theta &= \frac{\text{side adjacent to } \theta}{\text{side opposite } \theta}.\end{aligned}$$

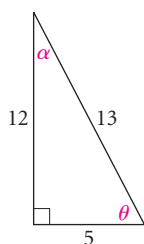

EXAMPLE 1 In the right triangle shown at left, find the six trigonometric function values of (a) θ and (b) α .

Solution We use the definitions.

$$\begin{aligned}\text{a) } \sin \theta &= \frac{\text{opp}}{\text{hyp}} = \frac{12}{13}, & \csc \theta &= \frac{\text{hyp}}{\text{opp}} = \frac{13}{12}, \\ \cos \theta &= \frac{\text{adj}}{\text{hyp}} = \frac{5}{13}, & \sec \theta &= \frac{\text{hyp}}{\text{adj}} = \frac{13}{5}, \\ \tan \theta &= \frac{\text{opp}}{\text{adj}} = \frac{12}{5}, & \cot \theta &= \frac{\text{adj}}{\text{opp}} = \frac{5}{12} \\ \text{b) } \sin \alpha &= \frac{\text{opp}}{\text{hyp}} = \frac{5}{13}, & \csc \alpha &= \frac{\text{hyp}}{\text{opp}} = \frac{13}{5}, \\ \cos \alpha &= \frac{\text{adj}}{\text{hyp}} = \frac{12}{13}, & \sec \alpha &= \frac{\text{hyp}}{\text{adj}} = \frac{13}{12}, \\ \tan \alpha &= \frac{\text{opp}}{\text{adj}} = \frac{5}{12}, & \cot \alpha &= \frac{\text{adj}}{\text{opp}} = \frac{12}{5}\end{aligned}$$

The references to opposite, adjacent, and hypotenuse are relative to θ .

The references to opposite, adjacent, and hypotenuse are relative to α .

➔ Now Try Exercise 1.

In Example 1(a), we note that the value of $\csc \theta$, $\frac{13}{12}$, is the reciprocal of $\frac{12}{13}$, the value of $\sin \theta$. Likewise, we see the same reciprocal relationship between the values of $\sec \theta$ and $\cos \theta$ and between the values of $\cot \theta$ and $\tan \theta$. For any angle, the cosecant, secant, and cotangent values are the reciprocals of the sine, cosine, and tangent function values, respectively.

Reciprocal Functions

$$\csc \theta = \frac{1}{\sin \theta}, \quad \sec \theta = \frac{1}{\cos \theta}, \quad \cot \theta = \frac{1}{\tan \theta}$$

If we know the values of the sine, cosine, and tangent functions of an angle, we can use these reciprocal relationships to find the values of the cosecant, secant, and cotangent functions of that angle.

STUDY TIP

Success on the next exam can be planned. Include study time (even if only 30 minutes a day) in your daily schedule and commit to making this time a *priority*. Choose a time when you are most alert and a setting in which you can concentrate. You will be surprised how much more you can learn and retain if study time is included each day rather than in one long session before the exam.

EXAMPLE 2 Given that $\sin \phi = \frac{4}{5}$, $\cos \phi = \frac{3}{5}$, and $\tan \phi = \frac{4}{3}$, find $\csc \phi$, $\sec \phi$, and $\cot \phi$.

Solution Using the reciprocal relationships, we have

$$\csc \phi = \frac{1}{\sin \phi} = \frac{1}{\frac{4}{5}} = \frac{5}{4}, \quad \sec \phi = \frac{1}{\cos \phi} = \frac{1}{\frac{3}{5}} = \frac{5}{3},$$

and

$$\cot \phi = \frac{1}{\tan \phi} = \frac{1}{\frac{4}{3}} = \frac{3}{4}.$$

➔ Now Try Exercise 7.

Triangles are said to be **similar** if their corresponding angles have the *same* measure. In similar triangles, the lengths of corresponding sides are in the same ratio. The right triangles shown below are similar. Note that the corresponding angles are equal and the length of each side of the second triangle is four times the length of the corresponding side of the first triangle.

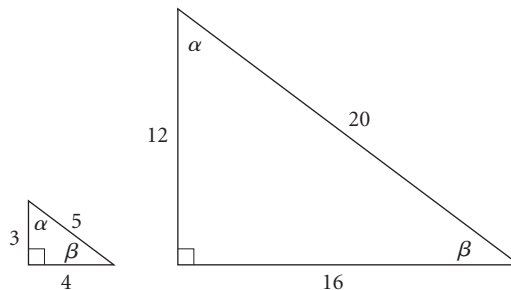

Let's observe the sine, cosine, and tangent values of β in each triangle. Can we expect corresponding function values to be the same?

FIRST TRIANGLE	SECOND TRIANGLE
$\sin \beta = \frac{3}{5}$	$\sin \beta = \frac{12}{20} = \frac{3}{5}$
$\cos \beta = \frac{4}{5}$	$\cos \beta = \frac{16}{20} = \frac{4}{5}$
$\tan \beta = \frac{3}{4}$	$\tan \beta = \frac{12}{16} = \frac{3}{4}$

For the two triangles, the corresponding values of $\sin \beta$, $\cos \beta$, and $\tan \beta$ are the same. The lengths of the sides are proportional—thus the

ratios are the same. This must be the case because in order for the sine, cosine, and tangent to be functions, there must be only one output (the ratio) for each input (the angle β).

The trigonometric function values of θ depend only on the measure of the angle, *not* on the size of the triangle.

► The Six Functions Related

We can find the other five trigonometric function values of an acute angle when one of the function-value ratios is known.

EXAMPLE 3 If $\sin \beta = \frac{6}{7}$ and β is an acute angle, find the other five trigonometric function values of β .

Solution We know from the definition of the sine function that the ratio

$$\frac{6}{7} \text{ is } \frac{\text{opp}}{\text{hyp}}.$$

Using this information, let's consider a right triangle in which the hypotenuse has length 7 and the side opposite β has length 6. To find the length of the side adjacent to β , we recall the *Pythagorean equation*:

PYTHAGOREAN EQUATION

REVIEW SECTION 1.1

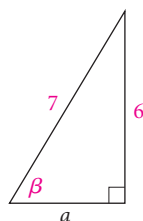

$$\begin{aligned} a^2 + b^2 &= c^2 \\ a^2 + 6^2 &= 7^2 \\ a^2 + 36 &= 49 \\ a^2 &= 49 - 36 = 13 \\ a &= \sqrt{13}. \end{aligned}$$

We now use the lengths of the three sides to find the other five ratios:

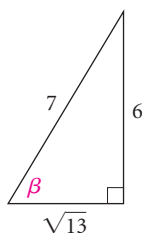

$$\begin{aligned} \sin \beta &= \frac{6}{7}, & \csc \beta &= \frac{7}{6}, \\ \cos \beta &= \frac{\sqrt{13}}{7}, & \sec \beta &= \frac{7}{\sqrt{13}}, \text{ or } \frac{7\sqrt{13}}{13}, \\ \tan \beta &= \frac{6}{\sqrt{13}}, \text{ or } \frac{6\sqrt{13}}{13}, & \cot \beta &= \frac{\sqrt{13}}{6}. \end{aligned}$$

➔ Now Try Exercise 9.

► Function Values of 30° , 45° , and 60°

In Examples 1 and 3, we found the trigonometric function values of an acute angle of a right triangle when the lengths of the three sides were known. In most situations, we are asked to find the function values when the measure of the acute angle is given. For certain special angles such as

30° , 45° , and 60° , which are frequently seen in applications, we can use geometry to determine the function values.

A right triangle with a 45° angle actually has two 45° angles. Thus the triangle is *isosceles*, and the legs are the same length. Let's consider such a triangle whose legs have length 1. Then we can find the length of its hypotenuse, c , using the Pythagorean equation as follows:

$$1^2 + 1^2 = c^2, \text{ or } c^2 = 2, \text{ or } c = \sqrt{2}.$$

Such a triangle is shown below. From this diagram, we can easily determine the trigonometric function values of 45° .

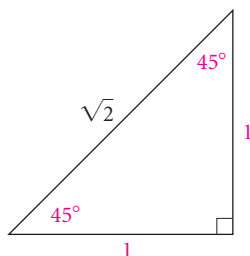

$$\sin 45^\circ = \frac{\text{opp}}{\text{hyp}} = \frac{1}{\sqrt{2}} = \frac{\sqrt{2}}{2} \approx 0.7071,$$

$$\cos 45^\circ = \frac{\text{adj}}{\text{hyp}} = \frac{1}{\sqrt{2}} = \frac{\sqrt{2}}{2} \approx 0.7071,$$

$$\tan 45^\circ = \frac{\text{opp}}{\text{adj}} = \frac{1}{1} = 1$$

It is sufficient to find only the function values of the sine, cosine, and tangent, since the others are their reciprocals.

It is also possible to determine the function values of 30° and 60° . A right triangle with 30° and 60° acute angles is half of an equilateral triangle, as shown in the following figure. Thus if we choose an equilateral triangle whose sides have length 2 and take half of it, we obtain a right triangle that has a hypotenuse of length 2 and a leg of length 1. The other leg has length a , which can be found as follows:

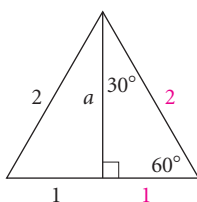

$$a^2 + 1^2 = 2^2$$

$$a^2 + 1 = 4$$

$$a^2 = 3$$

$$a = \sqrt{3}.$$

We can now determine the function values of 30° and 60° :

$$\sin 30^\circ = \frac{1}{2} = 0.5,$$

$$\sin 60^\circ = \frac{\sqrt{3}}{2} \approx 0.8660,$$

$$\cos 30^\circ = \frac{\sqrt{3}}{2} \approx 0.8660,$$

$$\cos 60^\circ = \frac{1}{2} = 0.5,$$

$$\tan 30^\circ = \frac{1}{\sqrt{3}} = \frac{\sqrt{3}}{3} \approx 0.5774,$$

$$\tan 60^\circ = \frac{\sqrt{3}}{1} = \sqrt{3} \approx 1.7321.$$

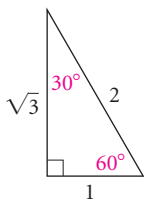

Since we will often use the function values of 30° , 45° , and 60° either the triangles that yield them or the values themselves should be memorized.

	30°	45°	60°
sin	1/2	$\sqrt{2}/2$	$\sqrt{3}/2$
cos	$\sqrt{3}/2$	$\sqrt{2}/2$	1/2
tan	$\sqrt{3}/3$	1	$\sqrt{3}$

Let's now use what we have learned about trigonometric functions of special angles to solve problems. We will consider such applications in greater detail in Section 6.2.

EXAMPLE 4 *Distance to Fire Cave.* Massive trees can survive wildfires that leave large caves in the trees (Source: *National Geographic*, October 2009, p. 32). A hiker observes scientists measuring a fire cave in a redwood tree in Prairie Creek Redwoods State Park. He estimates that he is 80 ft from the tree and that the angle between the ground and the line of sight to the scientists is 60°. Approximate how high the fire cave is. Round the answer to the nearest foot.

Solution We begin with a diagram of the situation. We know the measure of an acute angle and the length of the adjacent side.

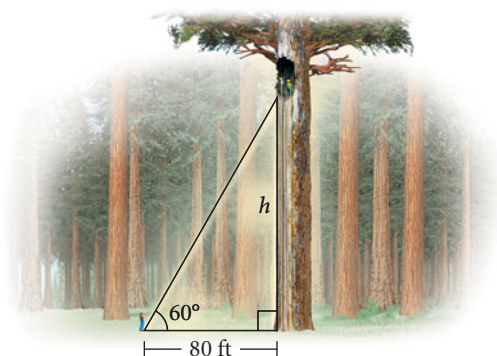

Since we want to determine the length of the opposite side, we can use the tangent ratio or the cotangent ratio. Here we use the tangent ratio:

$$\tan 60^\circ = \frac{\text{opp}}{\text{adj}} = \frac{h}{80}$$

$$80 \cdot \tan 60^\circ = h$$

$$80 \cdot \sqrt{3} = h \quad \text{Substituting; } \tan 60^\circ = \sqrt{3}$$

$$139 \approx h.$$

The fire cave is approximately 139 ft high.

 **Now Try Exercise 29.**

TECHNOLOGY CONNECTION

We can use a graphing calculator set in DEGREE mode to convert between D°M'S" form and decimal degree form.

NORMAL	SCI	ENG	
FLOAT	0123456789		
RADIAN	DEGREE		
FUNC	PAR	POL	SEQ
CONNECTED	DOT		
SEQUENTIAL	SIMUL		
REAL	a+bi	re-θi	
FULL	HORIZ	G-T	

To convert D°M'S" form to decimal degree form in Example 5, we enter 5°42'30" using the ANGLE menu for the degree and minute symbols and α + for the third symbol. Pressing ENTER gives us

$$5^\circ 42' 30'' \approx 5.71^\circ.$$

5°42'30"	5.708333333
----------	-------------

A number must always be entered for degrees even if it is 0. Also, if there is a nonzero number of seconds, both degrees and minutes must be entered even if one or both is 0.

To convert decimal degree form to D°M'S" form in Example 6, we enter 72.18 and access the ►DMS feature in the ANGLE menu.

72.18 ►DMS	72°10'48"
------------	-----------

► Function Values of Any Acute Angle

Historically, the measure of an angle has been expressed in degrees, minutes, and seconds. One minute, denoted 1', is such that $60' = 1^\circ$, or $1' = \frac{1}{60} \cdot (1^\circ)$. One second, denoted 1'', is such that $60'' = 1'$, or $1'' = \frac{1}{60} \cdot (1')$. Then 61 degrees, 27 minutes, 4 seconds could be written as $61^\circ 27' 4''$. This D°M'S" form was common before the widespread use of calculators. Now the preferred notation is to express fraction parts of degrees in **decimal degree form**. For example, $61^\circ 27' 4'' \approx 61.45^\circ$ in decimal degree form. Although the D°M'S" notation is still widely used in navigation, we will most often use the decimal form in this text.

Most calculators can convert D°M'S" notation to decimal degree notation and vice versa. Procedures among calculators vary.

EXAMPLE 5 Convert $5^\circ 42' 30''$ to decimal degree notation.

Solution We enter $5^\circ 42' 30''$. The calculator gives us

$$5^\circ 42' 30'' \approx 5.71^\circ,$$

rounded to the nearest hundredth of a degree.

Without a calculator, we can convert as follows:

$$\begin{aligned} 5^\circ 42' 30'' &= 5^\circ + 42' + 30'' \\ &= 5^\circ + 42' + \frac{30'}{60} & 1'' &= \frac{1'}{60}; 30'' = \frac{30'}{60} \\ &= 5^\circ + 42.5' & \frac{30'}{60} &= 0.5' \\ &= 5^\circ + \frac{42.5'}{60} & 1' &= \frac{1^\circ}{60}; 42.5' = \frac{42.5^\circ}{60} \\ &\approx 5.71^\circ. & \frac{42.5^\circ}{60} &\approx 0.71^\circ \end{aligned}$$

► Now Try Exercise 37.

EXAMPLE 6 Convert 72.18° to D°M'S" notation.

Solution On a calculator, we enter 72.18. The result is

$$72.18^\circ = 72^\circ 10' 48''.$$

Without a calculator, we can convert as follows:

$$\begin{aligned} 72.18^\circ &= 72^\circ + 0.18 \times 1^\circ \\ &= 72^\circ + 0.18 \times 60' & 1^\circ &= 60' \\ &= 72^\circ + 10.8' \\ &= 72^\circ + 10' + 0.8 \times 1' \\ &= 72^\circ + 10' + 0.8 \times 60'' & 1' &= 60'' \\ &= 72^\circ + 10' + 48'' \\ &= 72^\circ 10' 48''. \end{aligned}$$

► Now Try Exercise 45.

So far we have measured angles using degrees. Another useful unit for angle measure is the radian, which we will study in Section 6.4. Calculators work with either degrees or radians. Be sure to use whichever mode is appropriate. In this section, we use the DEGREE mode.

Keep in mind the difference between an exact answer and an approximation. For example,

$$\sin 60^\circ = \frac{\sqrt{3}}{2}. \quad \text{This is exact!}$$

But using a calculator, you get an answer like

$$\sin 60^\circ \approx 0.8660254038. \quad \text{This is an approximation!}$$

Calculators generally provide values only of the sine, cosine, and tangent functions. You can find values of the cosecant, secant, and cotangent by taking reciprocals of the sine, cosine, and tangent functions, respectively.

EXAMPLE 7 Find the trigonometric function value, rounded to four decimal places, of each of the following.

- a) $\tan 29.7^\circ$ b) $\sec 48^\circ$ c) $\sin 84^\circ 10' 39''$

Solution

- a) We check to be sure that the calculator is in DEGREE mode. The function value is

$$\begin{aligned} \tan 29.7^\circ &\approx 0.5703899297 \\ &\approx 0.5704. \quad \text{Rounded to four decimal places} \end{aligned}$$

- b) The secant function value can be found by taking the reciprocal of the cosine function value:

$$\sec 48^\circ = \frac{1}{\cos 48^\circ} \approx 1.49447655 \approx 1.4945.$$

- c) We enter $\sin 84^\circ 10' 39''$. The result is

$$\sin 84^\circ 10' 39'' \approx 0.9948409474 \approx 0.9948.$$

 **Now Try Exercises 61 and 69.**

We can use a calculator to find an angle for which we know a trigonometric function value.

EXAMPLE 8 Find the acute angle, to the nearest tenth of a degree, whose sine value is approximately 0.20113.

Solution The quickest way to find the angle with a calculator is to use an inverse function key. (We first studied inverse functions in Section 5.1 and will consider inverse *trigonometric* functions in Section 7.4.) First check to be sure that your calculator is in DEGREE mode. Usually two keys must be pressed in sequence. For this example, if we press

2ND **SIN** .20113 **ENTER**,

we find that the acute angle whose sine is 0.20113 is approximately 11.60304613° , or 11.6° .

 **Now Try Exercise 75.**



EXAMPLE 9 Ladder Safety. A window-washing crew has purchased new 30-ft extension ladders. The manufacturer states that the safest placement on a wall is to extend the ladder to 25 ft and to position the base 6.5 ft from the wall (*Source*: R. D. Werner Co., Inc.). What angle does the ladder make with the ground in this position?

Solution We make a drawing and then use the most convenient trigonometric function. Because we know the length of the side adjacent to θ and the length of the hypotenuse, we choose the cosine function.

From the definition of the cosine function, we have

$$\cos \theta = \frac{\text{adj}}{\text{hyp}} = \frac{6.5 \text{ ft}}{25 \text{ ft}} = 0.26.$$

Using a calculator, we find the acute angle whose cosine is 0.26:

$$\theta \approx 74.92993786^\circ. \quad \text{Pressing } \mathbf{2ND} \ \mathbf{COS} \ \mathbf{0.26} \ \mathbf{ENTER}$$

Thus when the ladder is in its safest position, it makes an angle of about 75° with the ground.

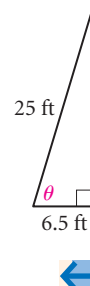

► Cofunctions and Complements

We recall that two angles are **complementary** whenever the sum of their measures is 90° . Each is the complement of the other. In a right triangle, the acute angles are complementary, since the sum of all three angle measures is 180° and the right angle accounts for 90° of this total. Thus if one acute angle of a right triangle is θ , the other is $90^\circ - \theta$.

The six trigonometric function values of each of the acute angles in the right triangle below are listed at the right. Note that 53° and 37° are complementary angles.

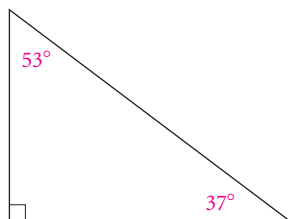

$\sin 37^\circ \approx 0.6018$	$\csc 37^\circ \approx 1.6616$
$\cos 37^\circ \approx 0.7986$	$\sec 37^\circ \approx 1.2521$
$\tan 37^\circ \approx 0.7536$	$\cot 37^\circ \approx 1.3270$
$\sin 53^\circ \approx 0.7986$	$\csc 53^\circ \approx 1.2521$
$\cos 53^\circ \approx 0.6018$	$\sec 53^\circ \approx 1.6616$
$\tan 53^\circ \approx 1.3270$	$\cot 53^\circ \approx 0.7536$

For these angles, we note that

$$\begin{aligned} \sin 37^\circ &= \cos 53^\circ, & \cos 37^\circ &= \sin 53^\circ, \\ \tan 37^\circ &= \cot 53^\circ, & \cot 37^\circ &= \tan 53^\circ, \\ \sec 37^\circ &= \csc 53^\circ, & \csc 37^\circ &= \sec 53^\circ. \end{aligned}$$

The sine of an angle is also the cosine of the angle's complement. Similarly, the tangent of an angle is the cotangent of the angle's complement, and the secant of an angle is the cosecant of the angle's complement. These pairs of functions are called **cofunctions**. A list of cofunction identities follows.

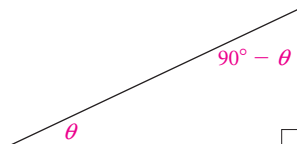

Cofunction Identities

$$\begin{aligned}\sin \theta &= \cos (90^\circ - \theta), & \cos \theta &= \sin (90^\circ - \theta), \\ \tan \theta &= \cot (90^\circ - \theta), & \cot \theta &= \tan (90^\circ - \theta), \\ \sec \theta &= \csc (90^\circ - \theta), & \csc \theta &= \sec (90^\circ - \theta)\end{aligned}$$

EXAMPLE 10 Given that $\sin 18^\circ \approx 0.3090$, $\cos 18^\circ \approx 0.9511$, and $\tan 18^\circ \approx 0.3249$, find the six trigonometric function values of 72° .

Solution Using reciprocal relationships, we know that

$$\csc 18^\circ = \frac{1}{\sin 18^\circ} \approx 3.2361,$$

$$\sec 18^\circ = \frac{1}{\cos 18^\circ} \approx 1.0515,$$

$$\text{and } \cot 18^\circ = \frac{1}{\tan 18^\circ} \approx 3.0777.$$

Since 72° and 18° are complementary, we have

$$\sin 72^\circ = \cos 18^\circ \approx 0.9511, \quad \cos 72^\circ = \sin 18^\circ \approx 0.3090,$$

$$\tan 72^\circ = \cot 18^\circ \approx 3.0777, \quad \cot 72^\circ = \tan 18^\circ \approx 0.3249,$$

$$\sec 72^\circ = \csc 18^\circ \approx 3.2361, \quad \csc 72^\circ = \sec 18^\circ \approx 1.0515.$$

Now Try Exercise 97.

6.1 Exercise Set

In Exercises 1–6, find the six trigonometric function values of the specified angle.

1.

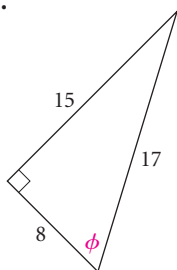

2.

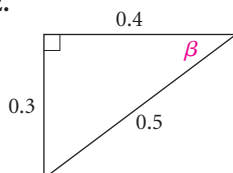

5.



3.

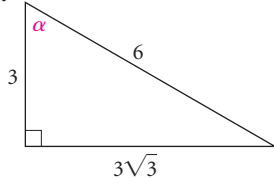

4.

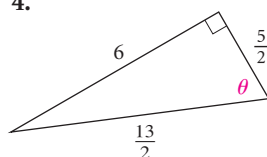

6.

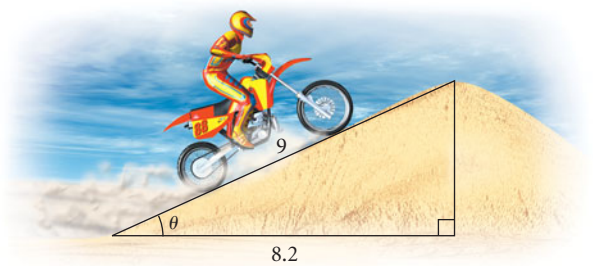

7. Given that $\sin \alpha = \frac{\sqrt{5}}{3}$, $\cos \alpha = \frac{2}{3}$, and

$\tan \alpha = \frac{\sqrt{5}}{2}$, find $\csc \alpha$, $\sec \alpha$, and $\cot \alpha$.

8. Given that $\sin \beta = \frac{2\sqrt{2}}{3}$, $\cos \beta = \frac{1}{3}$, and

$\tan \beta = 2\sqrt{2}$, find $\csc \beta$, $\sec \beta$, and $\cot \beta$.

Given a function value of an acute angle, find the other five trigonometric function values.

9. $\sin \theta = \frac{24}{25}$

10. $\cos \sigma = 0.7$

11. $\tan \phi = 2$

12. $\cot \theta = \frac{1}{3}$

13. $\csc \theta = 1.5$

14. $\sec \beta = \sqrt{17}$

15. $\cos \beta = \frac{\sqrt{5}}{5}$

16. $\sin \sigma = \frac{10}{11}$

Find the exact function value.

17. $\cos 45^\circ$

18. $\tan 30^\circ$

19. $\sec 60^\circ$

20. $\sin 45^\circ$

21. $\cot 60^\circ$

22. $\csc 45^\circ$

23. $\sin 30^\circ$

24. $\cos 60^\circ$

25. $\tan 45^\circ$

26. $\sec 30^\circ$

27. $\csc 30^\circ$

28. $\tan 60^\circ$

29. **Four Square.** The game Four Square is making a comeback on college campuses. The game is played on a 16-ft square court divided into four smaller squares that meet in the center (*Source:* www.squarefour.org/rules). If a line is drawn diagonally from one corner to another corner, then a right triangle QTS is formed, where $\angle QTS$ is 45° . Using a trigonometric function, find the length of the diagonal. Round the answer to the nearest tenth of a foot.

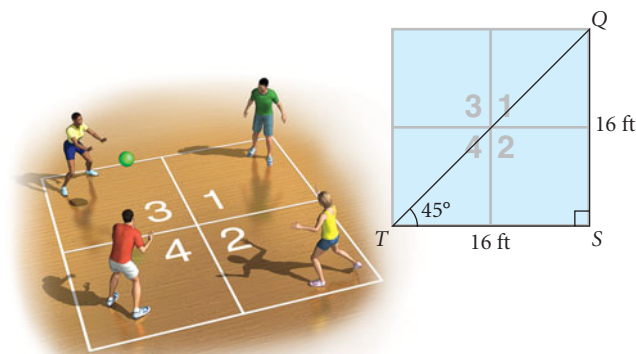

30. **Height of a Hot-Air Balloon.** As a hot-air balloon began to rise, the ground crew drove 1.2 mi to an observation station. The initial observation from the station estimated the angle between the ground and the line of sight to the balloon to be 30° . Approximately how high was the balloon at that point? (We are assuming that the wind velocity was low and that the balloon rose vertically for the first few minutes.)

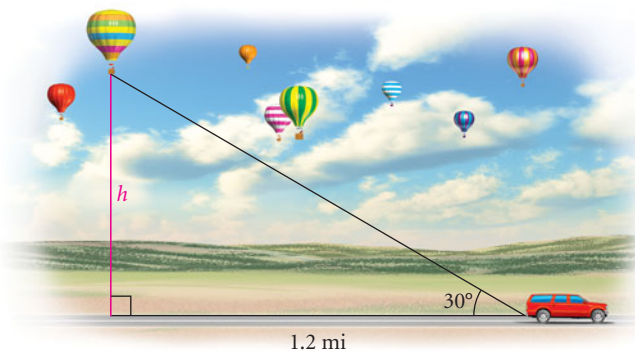

Convert to decimal degree notation. Round to two decimal places.

31. $9^\circ 43'$

32. $52^\circ 15'$

33. $35^\circ 50''$

34. $64^\circ 53''$

35. $3^\circ 2'$

36. $19^\circ 47' 23''$

37. $49^\circ 38' 46''$

38. $76^\circ 11' 34''$

39. $15' 5''$

40. $68^\circ 2''$

41. $5^\circ 53''$

42. $44' 10''$

Convert to degrees, minutes, and seconds. Round to the nearest second.

43. 17.6°

44. 20.14°

45. 83.025°

46. 67.84°

47. 11.75°

48. 29.8°

49. 47.8268°

50. 0.253°

51. 0.9°

52. 30.2505°

53. 39.45°

54. 2.4°

Find the function value. Round to four decimal places.

55. $\cos 51^\circ$

56. $\cot 17^\circ$

57. $\tan 4^\circ 13'$

58. $\sin 26.1^\circ$

59. $\sec 38.43^\circ$

60. $\cos 74^\circ 10' 40''$

61. $\cos 40.35^\circ$ 62. $\csc 45.2^\circ$
 63. $\sin 69^\circ$ 64. $\tan 63^\circ 48'$
 65. $\tan 85.4^\circ$ 66. $\cos 4^\circ$
 67. $\csc 89.5^\circ$ 68. $\sec 35.28^\circ$
 69. $\cot 30^\circ 25' 6''$ 70. $\sin 59.2^\circ$

Find the acute angle θ , to the nearest tenth of a degree, for the given function value.

71. $\sin \theta = 0.5125$ 72. $\tan \theta = 2.032$
 73. $\tan \theta = 0.2226$ 74. $\cos \theta = 0.3842$
 75. $\sin \theta = 0.9022$ 76. $\tan \theta = 3.056$
 77. $\cos \theta = 0.6879$ 78. $\sin \theta = 0.4005$
 79. $\cot \theta = 2.127$ 80. $\csc \theta = 1.147$

$$\left(\text{Hint: } \tan \theta = \frac{1}{\cot \theta} \right)$$

81. $\sec \theta = 1.279$ 82. $\cot \theta = 1.351$

Find the exact acute angle θ for the given function value.

83. $\sin \theta = \frac{\sqrt{2}}{2}$ 84. $\cot \theta = \frac{\sqrt{3}}{3}$
 85. $\cos \theta = \frac{1}{2}$ 86. $\sin \theta = \frac{1}{2}$
 87. $\tan \theta = 1$ 88. $\cos \theta = \frac{\sqrt{3}}{2}$
 89. $\csc \theta = \frac{2\sqrt{3}}{3}$ 90. $\tan \theta = \sqrt{3}$
 91. $\cot \theta = \sqrt{3}$ 92. $\sec \theta = \sqrt{2}$

Use the cofunction and reciprocal identities to complete each of the following.

93. $\cos 20^\circ = \underline{\hspace{1cm}} 70^\circ = \frac{1}{\underline{\hspace{1cm}} 20^\circ}$
 94. $\sin 64^\circ = \underline{\hspace{1cm}} 26^\circ = \frac{1}{\underline{\hspace{1cm}} 64^\circ}$
 95. $\tan 52^\circ = \cot \underline{\hspace{1cm}} = \frac{1}{\underline{\hspace{1cm}} 52^\circ}$
 96. $\sec 13^\circ = \csc \underline{\hspace{1cm}} = \frac{1}{\underline{\hspace{1cm}} 13^\circ}$

97. Given that

$$\begin{aligned} \sin 65^\circ &\approx 0.9063, & \cos 65^\circ &\approx 0.4226, \\ \tan 65^\circ &\approx 2.1445, & \cot 65^\circ &\approx 0.4663, \\ \sec 65^\circ &\approx 2.3662, & \csc 65^\circ &\approx 1.1034, \end{aligned}$$

find the six function values of 25° .

98. Given that

$$\begin{aligned} \sin 8^\circ &\approx 0.1392, & \cos 8^\circ &\approx 0.9903, \\ \tan 8^\circ &\approx 0.1405, & \cot 8^\circ &\approx 7.1154, \\ \sec 8^\circ &\approx 1.0098, & \csc 8^\circ &\approx 7.1853, \end{aligned}$$

find the six function values of 82° .

99. Given that $\sin 71^\circ 10' 5'' \approx 0.9465$,

$$\cos 71^\circ 10' 5'' \approx 0.3228, \text{ and}$$

$$\tan 71^\circ 10' 5'' \approx 2.9321,$$

find the six function values of $18^\circ 49' 55''$.

100. Given that $\sin 38.7^\circ \approx 0.6252$,

$$\cos 38.7^\circ \approx 0.7804, \text{ and } \tan 38.7^\circ \approx 0.8012,$$

find the six function values of 51.3° .

101. Given that $\sin 82^\circ = p$, $\cos 82^\circ = q$, and

$\tan 82^\circ = r$, find the six function values of 8° in terms of p , q , and r .

Skill Maintenance

Graph the function.

102. $f(x) = 2^{-x}$

103. $f(x) = e^{x/2}$

104. $g(x) = \log_2 x$

105. $h(x) = \ln x$

Solve.

106. $e^t = 10,000$

107. $5^x = 625$

108. $\log(3x + 1) - \log(x - 1) = 2$

109. $\log_7 x = 3$

Synthesis

110. Given that $\cos \theta = 0.9651$, find $\csc(90^\circ - \theta)$.

111. Given that $\sec \beta = 1.5304$, find $\sin(90^\circ - \beta)$.

112. Find the six trigonometric function values of α .

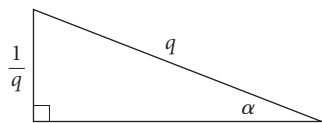

113. Show that the area of this right triangle is $\frac{1}{2}bc \sin A$.

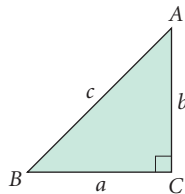

114. Show that the area of this triangle is $\frac{1}{2}ab \sin \theta$.

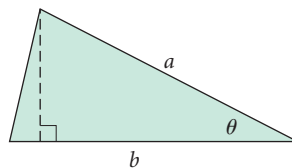

Applications of Right Triangles

6.2

- ▶ Solve right triangles.
- ▶ Solve applied problems involving right triangles and trigonometric functions.

▶ Solving Right Triangles

Now that we can find function values for any acute angle, it is possible to *solve* right triangles. To **solve** a triangle means to find the lengths of *all* sides and the measures of *all* angles.

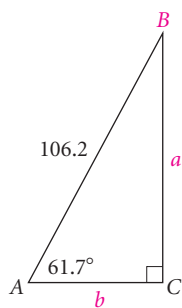

EXAMPLE 1 In $\triangle ABC$ (shown at left), find a , b , and B , where a and b represent lengths of sides and B represents the measure of $\angle B$. Here we use standard lettering for naming the sides and the angles of a right triangle: Side a is opposite angle A , side b is opposite angle B , where a and b are the legs, and side c , the hypotenuse, is opposite angle C , the right angle.

Solution In $\triangle ABC$, we know three of the measures:

$$A = 61.7^\circ, \quad a = ?,$$

$$B = ?, \quad b = ?,$$

$$C = 90^\circ, \quad c = 106.2.$$

Since the sum of the angle measures of any triangle is 180° and $C = 90^\circ$, the sum of A and B is 90° . Thus,

$$B = 90^\circ - A = 90^\circ - 61.7^\circ = 28.3^\circ.$$

We are given an acute angle and the hypotenuse. This suggests that we can use the sine and cosine ratios to find a and b , respectively:

$$\sin 61.7^\circ = \frac{\text{opp}}{\text{hyp}} = \frac{a}{106.2} \quad \text{and} \quad \cos 61.7^\circ = \frac{\text{adj}}{\text{hyp}} = \frac{b}{106.2}.$$

Solving for a and b and rounding to the nearest tenth, we get

$$a = 106.2 \sin 61.7^\circ \quad \text{and} \quad b = 106.2 \cos 61.7^\circ$$

$$a \approx 93.5 \qquad \qquad \qquad b \approx 50.3.$$

Thus,

$$A = 61.7^\circ, \quad a \approx 93.5,$$

$$B = 28.3^\circ, \quad b \approx 50.3,$$

$$C = 90^\circ, \quad c = 106.2.$$

 **Now Try Exercise 1.**

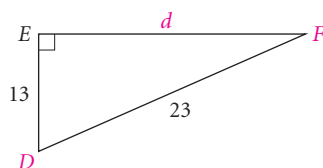

EXAMPLE 2 In $\triangle DEF$ (shown at left), find D and F . Then find d .

Solution In $\triangle DEF$, we know three of the measures:

$$D = ?, \quad d = ?,$$

$$E = 90^\circ, \quad e = 23,$$

$$F = ?, \quad f = 13.$$

We know the side adjacent to D and the hypotenuse. This suggests the use of the cosine ratio:

$$\cos D = \frac{\text{adj}}{\text{hyp}} = \frac{13}{23}.$$

We now find the angle whose cosine is $\frac{13}{23}$. To the nearest hundredth of a degree,

$$D \approx 55.58^\circ. \quad \text{Pressing } \mathbf{2ND} \ \mathbf{COS} \ (13/23) \ \mathbf{ENTER}$$

Since the sum of D and F is 90° , we can find F by subtracting:

$$F = 90^\circ - D \approx 90^\circ - 55.58^\circ \approx 34.42^\circ.$$

We could use the Pythagorean equation to find d , but we will use a trigonometric function here. We could use $\cos F$, $\sin D$, or the tangent or cotangent ratio for either D or F . Let's use $\tan D$:

$$\tan D = \frac{\text{opp}}{\text{adj}} = \frac{d}{13}, \quad \text{or} \quad \tan 55.58^\circ \approx \frac{d}{13}.$$

Then

$$d \approx 13 \tan 55.58^\circ \approx 19.$$

The six measures are

$$D \approx 55.58^\circ, \quad d \approx 19,$$

$$E = 90^\circ, \quad e = 23,$$

$$F \approx 34.42^\circ, \quad f = 13.$$

 **Now Try Exercise 9.**

► Applications

Right triangles can be used to model and solve many applied problems.

EXAMPLE 3 *Walking at Niagara Falls.* While visiting Niagara Falls, a tourist walking toward Horseshoe Falls on a walkway next to Niagara Parkway notices the entrance to the Cave of the Winds attraction directly across the Niagara River. She continues walking for another 1000 ft and finds that the entrance is still visible but at approximately a 50° angle to the walkway.



- How many feet is she from the entrance to the Cave of the Winds?
- What is the approximate width of the Niagara River at that point?

Solution

- We know the side adjacent to the 50° angle and want to find the hypotenuse. We can use the cosine function:

$$\begin{aligned}\cos 50^\circ &= \frac{1000 \text{ ft}}{c} \\ c &= \frac{1000 \text{ ft}}{\cos 50^\circ} \approx 1556 \text{ ft.}\end{aligned}$$

After walking 1000 ft, she is approximately 1556 ft from the entrance to the Cave of the Winds.

- We know the side adjacent to the 50° angle and want to find the opposite side. We can use the tangent function:

$$\begin{aligned}\tan 50^\circ &= \frac{b}{1000 \text{ ft}} \\ b &= 1000 \text{ ft} \cdot \tan 50^\circ \approx 1192 \text{ ft.}\end{aligned}$$

The width of the Niagara River is approximately 1192 ft at that point.

➔ Now Try Exercise 21.

EXAMPLE 4 *Rafters for a House.* House framers can use trigonometric functions to determine the lengths of rafters for a house. They first choose the pitch of the roof, or the ratio of the rise over the run. Then using a triangle

with that ratio, they calculate the length of the rafter needed for the house. José is constructing rafters for a roof with a 10/12 pitch on a house that is 42 ft wide. Find the length x of the rafter of the house to the nearest tenth of a foot.

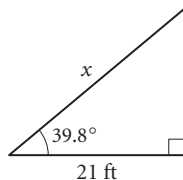
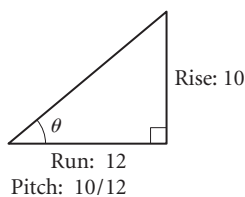
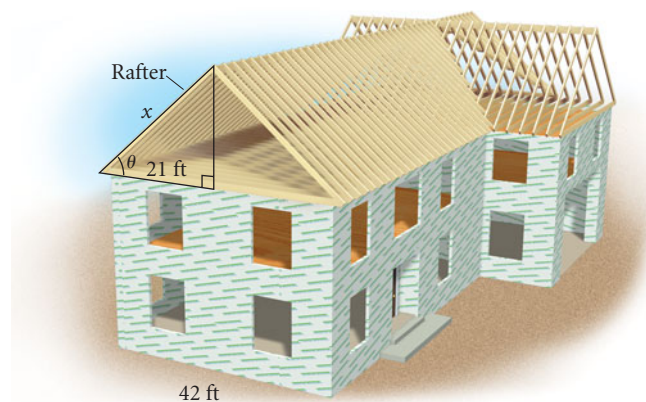

Solution We first find the angle θ that the rafter makes with the side wall. We know the rise, 10, and the run, 12, so we can use the tangent function to determine the angle that corresponds to the pitch of 10/12:

$$\tan \theta = \frac{10}{12} \approx 0.8333.$$

Using a calculator, we find that $\theta \approx 39.8^\circ$. Since trigonometric function values of θ depend only on the measure of the angle and not on the size of the triangle, the angle for the rafter is also 39.8° .

To determine the length x of the rafter, we can use the cosine function. (See the figure at left.) Note that the width of the house is 42 ft, and a leg of this triangle is half that length, 21 ft.

$$\cos 39.8^\circ = \frac{21 \text{ ft}}{x}$$

$$x \cos 39.8^\circ = 21 \text{ ft}$$

Multiplying by x

$$x = \frac{21 \text{ ft}}{\cos 39.8^\circ}$$

Dividing by $\cos 39.8^\circ$

$$x \approx 27.3 \text{ ft}$$

The length of the rafter for this house is approximately 27.3 ft.

Now Try Exercise 33.

Many applications with right triangles involve an *angle of elevation* or an *angle of depression*. The angle between the horizontal and a line of sight above the horizontal is called an **angle of elevation**. The angle between the horizontal and a line of sight below the horizontal is called an **angle of depression**. For example, suppose that you are looking straight ahead and then you move your eyes up to look at an approaching airplane. The angle that your eyes pass through is an angle of elevation. If the pilot of the plane is

looking forward and then looks down, the pilot's eyes pass through an angle of depression.

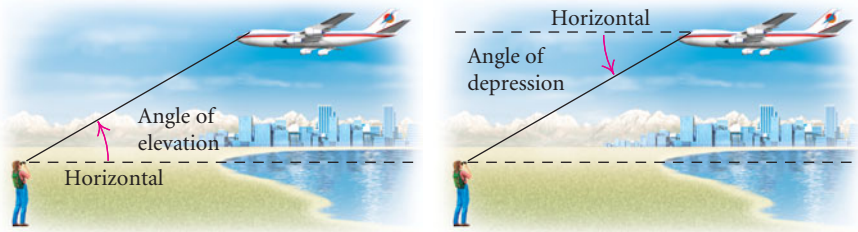

EXAMPLE 5 Gondola Aerial Lift. In Telluride, Colorado, there is a free gondola ride that provides a spectacular view of the town and the surrounding mountains. The gondolas that begin in the town at an elevation of 8725 ft travel 5750 ft to Station St. Sophia, whose altitude is 10,550 ft. They then continue 3913 ft to Mountain Village, whose elevation is 9500 ft.

- What is the angle of elevation from the town to Station St. Sophia?
- What is the angle of depression from Station St. Sophia to Mountain Village?

Solution We begin by labeling a drawing with the given information.

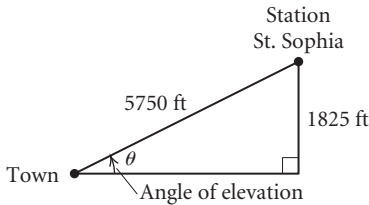
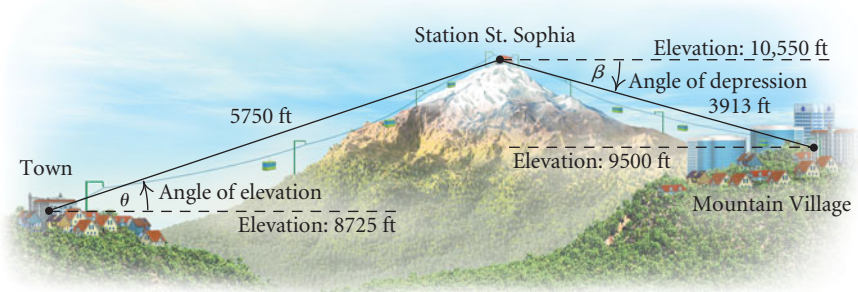

- The difference in the elevation of Station St. Sophia and the elevation of the town is $10,550 \text{ ft} - 8725 \text{ ft}$, or 1825 ft. This measure is the length of the side opposite the angle of elevation, θ , in the right triangle shown at left. Since we know the side opposite θ and the hypotenuse, we can find θ by using the sine function. We first find $\sin \theta$:

$$\sin \theta = \frac{1825 \text{ ft}}{5750 \text{ ft}} \approx 0.3174.$$

Using a calculator, we find that

$$\theta \approx 18.5^\circ. \quad \text{Pressing } \mathbf{2ND} \ \mathbf{SIN} \ \mathbf{0.3174} \ \mathbf{ENTER}$$

Thus the angle of elevation from the town to Station St. Sophia is approximately 18.5° .

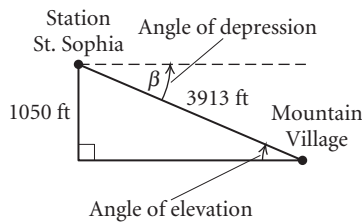

- When parallel lines are cut by a transversal, alternate interior angles are equal. Thus the angle of depression, β , from Station St. Sophia to Mountain Village is equal to the angle of elevation from Mountain Village to Station St. Sophia, so we can use the right triangle shown at left.

The difference in the elevation of Station St. Sophia and the elevation of Mountain Village is $10,550 \text{ ft} - 9500 \text{ ft}$, or 1050 ft . Since we know the side opposite the angle of elevation and the hypotenuse, we can again use the sine function:

$$\sin \beta = \frac{1050 \text{ ft}}{3913 \text{ ft}} \approx 0.2683.$$

Using a calculator, we find that

$$\beta \approx 15.6^\circ.$$

The angle of depression from Station St. Sophia to Mountain Village is approximately 15.6° .

 **Now Try Exercise 17.**



EXAMPLE 6 *Height of a Bamboo Plant.* Bamboo is the fastest growing land plant in the world and is becoming a popular wood for hardwood flooring. It can grow up to 46 in. per day and reaches its maximum height and girth in one season of growth. (Sources: *Farm Show*, Vol. 34, No. 4, 2010, p. 7; *U-Cut Bamboo Business*; American Bamboo Society) To estimate the height of a bamboo shoot, a farmer walks off 27 ft from the base and estimates the angle of elevation to the top of the shoot to be 70° . Approximately how tall is the bamboo shoot?

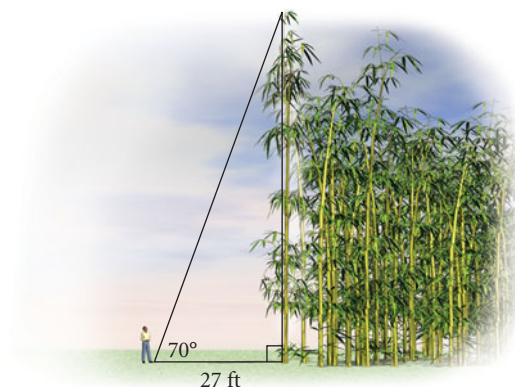

Solution From the figure, we have

$$\tan 70^\circ = \frac{h}{27 \text{ ft}}$$

$$h = 27 \text{ ft} \cdot \tan 70^\circ \approx 74 \text{ ft}.$$

The height of the bamboo shoot is approximately 74 ft.

 **Now Try Exercise 25.**

Some applications of trigonometry involve the concept of direction, or bearing. In this text, we present two ways of giving direction, the first below and the second in Section 6.3.

Bearing: First-Type. One method of giving direction, or **bearing**, involves reference to a north–south line using an acute angle. For example, $N55^\circ W$ means 55° west of north and $S67^\circ E$ means 67° east of south.

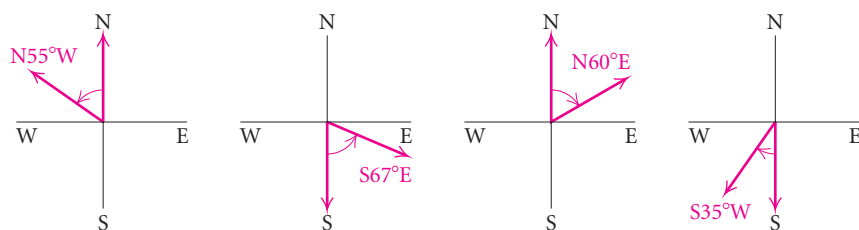

EXAMPLE 7 Distance to a Forest Fire. A forest ranger at point A sights a fire directly south. A second ranger at point B , 7.5 mi east, sights the same fire at a bearing of $S27^\circ 23' W$. How far from A is the fire?

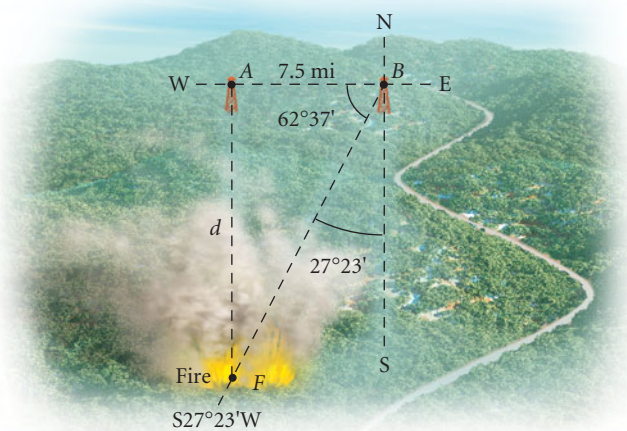

Solution We first find the complement of $27^\circ 23'$:

$$\begin{aligned} B &= 90^\circ - 27^\circ 23' && \text{Angle } B \text{ is opposite side } d \text{ in the right triangle.} \\ &= 62^\circ 37' \\ &\approx 62.62^\circ. \end{aligned}$$

From the figure shown above, we see that the desired distance d is part of a right triangle. We have

$$\frac{d}{7.5 \text{ mi}} \approx \tan 62.62^\circ$$

$$d \approx 7.5 \text{ mi} \cdot \tan 62.62^\circ \approx 14.5 \text{ mi.}$$

The forest ranger at point A is about 14.5 mi from the fire.

Now Try Exercise 37.



EXAMPLE 8 U.S. Cellular Field. In U.S. Cellular Field, the home of the Chicago White Sox baseball team, the first row of seats in the upper deck is farther away from home plate than the last row of seats in the original Comiskey Park. Although there is no obstructed view in U.S. Cellular Field, some of the fans still complain about the present distance from home plate to the upper deck of seats. From a seat in the last row of the upper deck directly behind the batter, the angle of depression to home plate is 29.9° , and the angle of depression to the pitcher's mound is 24.2° . Find the viewing distance to home plate and the viewing distance to the pitcher's mound.

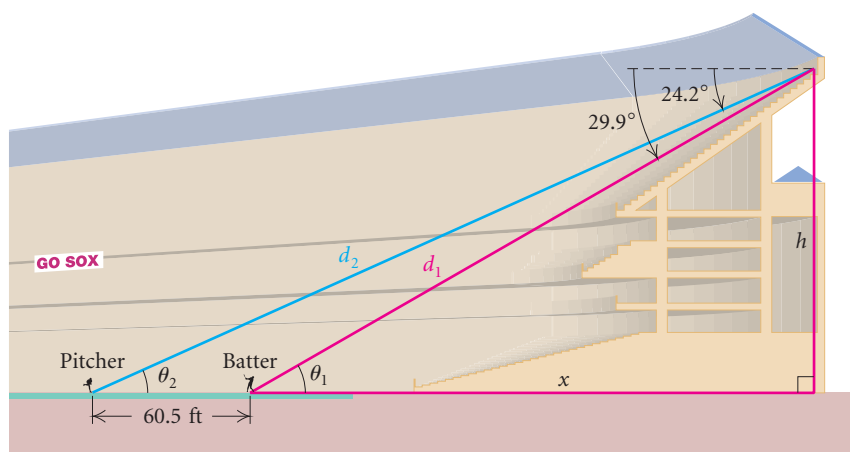

Solution From geometry we know that $\theta_1 = 29.9^\circ$ and $\theta_2 = 24.2^\circ$. The standard distance from home plate to the pitcher's mound is 60.5 ft. In the drawing, we let d_1 = the viewing distance to home plate, d_2 the viewing distance to the pitcher's mound, h the elevation of the last row, and x the horizontal distance from the batter to a point directly below the seat in the last row of the upper deck.

We begin by determining the distance x . We use the tangent function with $\theta_1 = 29.9^\circ$ and $\theta_2 = 24.2^\circ$:

$$\tan 29.9^\circ = \frac{h}{x} \quad \text{and} \quad \tan 24.2^\circ = \frac{h}{x + 60.5}$$

or

$$h = x \tan 29.9^\circ \quad \text{and} \quad h = (x + 60.5) \tan 24.2^\circ.$$

Then substituting $x \tan 29.9^\circ$ for h in the second equation, we obtain

$$x \tan 29.9^\circ = (x + 60.5) \tan 24.2^\circ.$$

Solving for x , we get

$$\begin{aligned} x \tan 29.9^\circ &= x \tan 24.2^\circ + 60.5 \tan 24.2^\circ \\ x \tan 29.9^\circ - x \tan 24.2^\circ &= x \tan 24.2^\circ + 60.5 \tan 24.2^\circ - x \tan 24.2^\circ \\ x(\tan 29.9^\circ - \tan 24.2^\circ) &= 60.5 \tan 24.2^\circ \end{aligned}$$

$$x = \frac{60.5 \tan 24.2^\circ}{\tan 29.9^\circ - \tan 24.2^\circ}$$

$$x \approx 216.5.$$

We can then find d_1 and d_2 using the cosine function:

$$\cos 29.9^\circ = \frac{216.5}{d_1} \quad \text{and} \quad \cos 24.2^\circ = \frac{216.5 + 60.5}{d_2}$$

or

$$d_1 = \frac{216.5}{\cos 29.9^\circ} \quad \text{and} \quad d_2 = \frac{277}{\cos 24.2^\circ}$$

$$d_1 \approx 249.7 \quad d_2 \approx 303.7$$

The viewing distance to home plate is about 250 ft,* and the viewing distance to the pitcher's mound is about 304 ft. 

6.2 Exercise Set

In Exercises 1–6, solve the right triangle.

1.

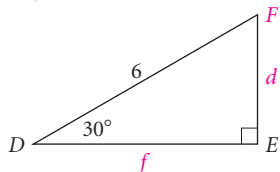

2.

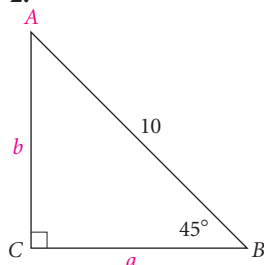

3.

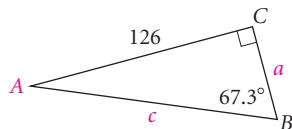

4.

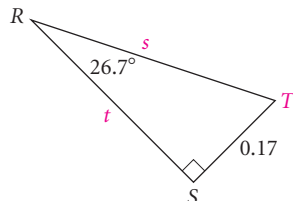

5.

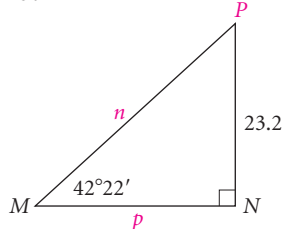

6.

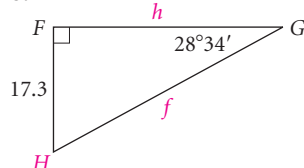

In Exercises 7–16, solve the right triangle. (Standard lettering has been used.)

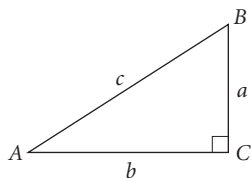

7. $A = 87^\circ 43'$, $a = 9.73$

8. $a = 12.5$, $b = 18.3$

9. $b = 100$, $c = 450$

10. $B = 56.5^\circ$, $c = 0.0447$

11. $A = 47.58^\circ$, $c = 48.3$

12. $B = 20.6^\circ$, $a = 7.5$

13. $A = 35^\circ$, $b = 40$

14. $B = 69.3^\circ$, $b = 93.4$

15. $b = 1.86$, $c = 4.02$

16. $a = 10.2$, $c = 20.4$

17. **Aerial Photography.** An aerial photographer who photographs farm properties for a real estate company has determined from experience that the best photo is taken at a height of approximately 475 ft and a distance of 850 ft from the farmhouse. What is the angle of depression from the plane to the house?

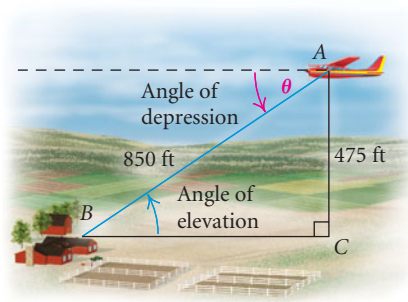

*In the original Comiskey Park, the viewing distance to home plate was only 150 ft.

18. **Memorial Flag Case.** A tradition in the United States is to drape an American flag over the casket of a deceased U.S. Forces veteran. At the burial, the flag is removed, folded into a triangle, and presented to the family. The folded flag will fit in an isosceles right triangle case, as shown below. The inside dimension across the bottom of the case is $21\frac{1}{2}$ in. (Source: Bruce Kieffer, *Woodworker's Journal*, August 2006). Using trigonometric functions, find the length x and round the answer to the nearest tenth of an inch.

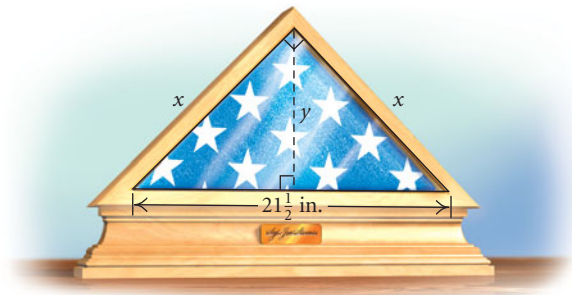

19. **Longest Zip Line.** The longest zip line in the world is the ZipRider® at Icy Straight Point, Alaska. Its length is 5495 ft, and it has a vertical drop of 1320 ft (Source: www.ziprider.com). Find its angle of depression.



20. **Setting a Fishing Reel Line Counter.** A fisherman who is fishing 50 ft directly out from a visible tree stump near the shore wants to position his line and bait approximately $N35^\circ W$ of the boat and west of the stump. Using the right triangle shown in the drawing, determine the reel's line counter setting, to

the nearest foot, to position the line directly west of the stump.

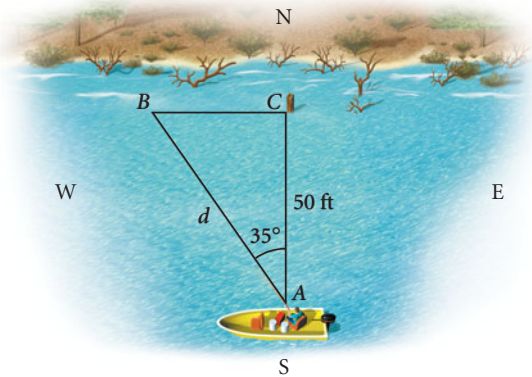

21. **Framing a Closet.** Sam is framing a closet under a stairway. The stairway is 16 ft 3 in. long, and its angle of elevation is 38° . Find the depth of the closet to the nearest inch.

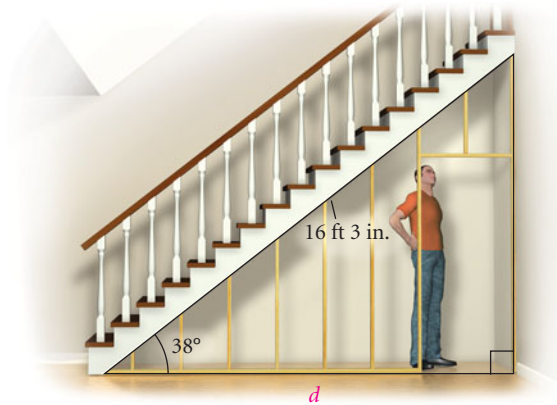

22. **Loading Ramp.** Charles needs to purchase a custom ramp to use while loading and unloading a garden tractor. When down, the tailgate of his truck is 38 in. from the ground. If the recommended angle that the ramp makes with the ground is 28° , approximately how long does the ramp need to be?



23. **Ski Dubai Resort.** Ski Dubai is the first indoor ski resort in the Middle East. The longest ski run drops 60 ft and has an angle of depression of approximately 8.6° (Source: www.SkiDubai.com). Find the length of the ski run. Round the answer to the nearest foot.



24. **Cloud Height.** To measure cloud height at night, a vertical beam of light is directed on a spot on the cloud. From a point 135 ft away from the light source, the angle of elevation to the spot is found to be 67.35° . Find the height of the cloud to the nearest foot.

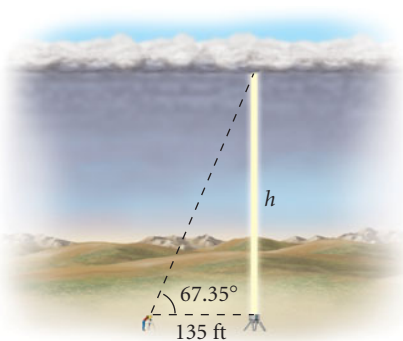

25. **Mount Rushmore National Memorial.** While visiting Mount Rushmore in Rapid City, South Dakota, Landon approximated the angle of elevation to the top of George Washington's head to be 35° . After walking 250 ft closer, he guessed that the angle of elevation had increased by 15° . Approximate the height of the Mount Rushmore memorial, to the top of George

Washington's head. Round the answer to the nearest foot.

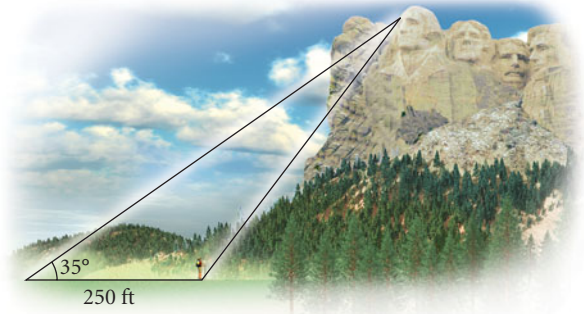

26. **Golden Gate Bridge.** The Golden Gate Bridge has two main towers of equal height that support the two main cables. A visitor on a tour boat passing through San Francisco Bay views the top of one of the towers and estimates the angle of elevation to be 30° . After sailing 670 ft closer, he estimates the angle of elevation to this same tower to be 50° . Approximate the height of the tower to the nearest foot.

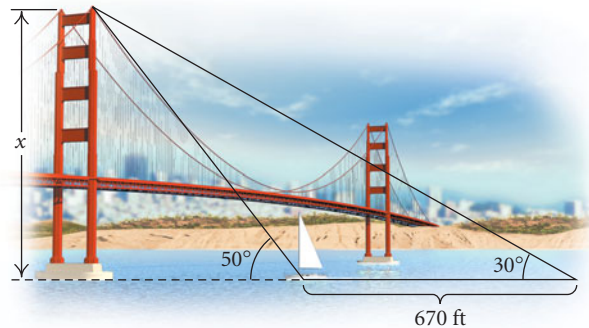

27. **Inscribed Pentagon.** A regular pentagon is inscribed in a circle of radius 15.8 cm. Find the perimeter of the pentagon.
28. **Height of a Weather Balloon.** A weather balloon is directly west of two observing stations that are 10 mi apart. The angles of elevation of the balloon from the two stations are 17.6° and 78.2° . How high is the balloon?
29. **Height of a Building.** A window washer on a ladder looks at a nearby building 100 ft away, noting that the

angle of elevation to the top of the building is 18.7° and the angle of depression to the bottom of the building is 6.5° . How tall is the nearby building?

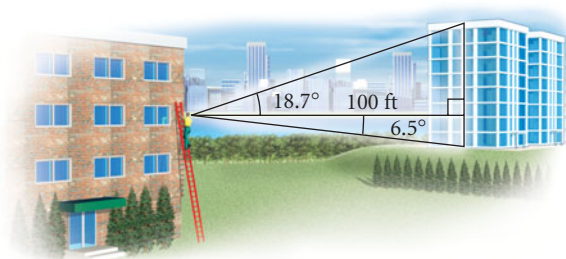

30. **Height of a Kite.** For a science fair project, a group of students tested different materials used to construct kites. Their instructor provided an instrument that accurately measures the angle of elevation. In one of the tests, the angle of elevation was 63.4° with 670 ft of string out. Assuming the string was taut, how high was the kite?
31. **Quilt Design.** Nancy is designing a quilt that she will enter in the quilt competition at the State Fair. The quilt consists of twelve identical squares with 4 rows of 3 squares each. Each square is to have a regular octagon inscribed in a circle, as shown in the figure. Each side of the octagon is to be 7 in. long. Find the radius of the circumscribed circle and the dimensions of the quilt. Round the answers to the nearest hundredth of an inch.

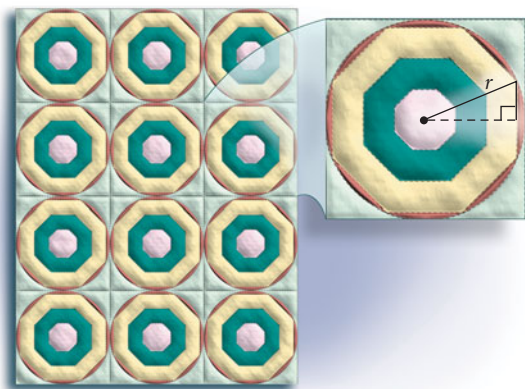

32. **Rafters for a House.** Blaise, an architect for luxury homes, is designing a house that is 46 ft wide with a roof whose pitch is $11/12$. Determine the length of

the rafters needed for this house. Round the answer to the nearest tenth of a foot.

33. **Rafters for a Medical Office.** The pitch of the roof for a medical office needs to be $5/12$. If the building is 33 ft wide, how long must the rafters be?
34. **Angle of Elevation.** The Millau Viaduct in southern France is the tallest cable-stayed bridge in the world (*Source:* www.abelard.org/france/viaduct-de-millau.php). What is the angle of elevation of the sun when a pylon with height 343 m casts a shadow of 186 m?



35. **Distance Between Towns.** From a hot-air balloon 2 km high, the angles of depression to two towns in line with the balloon are 81.2° and 13.5° . How far apart are the towns?
36. **Distance from a Lighthouse.** From the top of a lighthouse 55 ft above sea level, the angle of depression to a small boat is 11.3° . How far from the foot of the lighthouse is the boat?
37. **Lightning Detection.** In extremely large forests, it is not cost-effective to position forest rangers in towers or to use small aircraft to continually watch for fires. Since lightning is a frequent cause of fire, lightning detectors are now commonly used instead. These devices not only give a bearing on the location but also measure the intensity of the lightning. A detector at point Q is situated 15 mi west of a central fire station at point R. The bearing from Q to where

lightning hits due south of R is $S37.6^\circ E$. How far is the hit from point R ?

38. **Length of an Antenna.** A vertical antenna is mounted atop a 50-ft pole. From a point on level ground 75 ft from the base of the pole, the antenna subtends an angle of 10.5° . Find the length of the antenna.

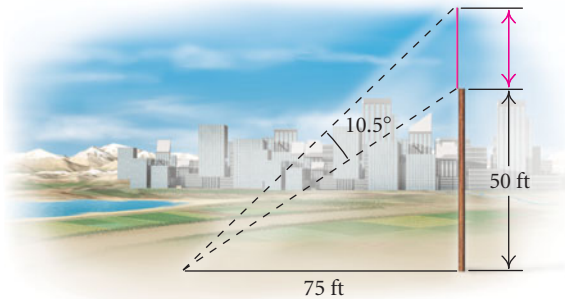

39. **Lobster Boat.** A lobster boat is situated due west of a lighthouse. A barge is 12 km south of the lobster boat. From the barge, the bearing to the lighthouse is $N63^\circ 20' E$. How far is the lobster boat from the lighthouse?

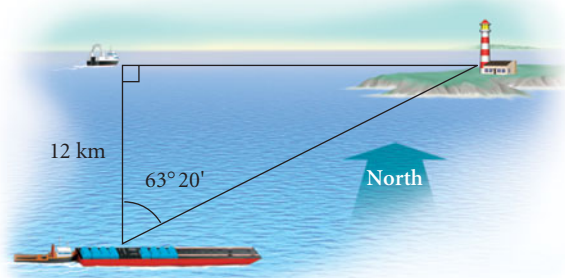

Skill Maintenance

Find the distance between the points.

40. $(-9, 3)$ and $(0, 0)$
 41. $(8, -2)$ and $(-6, -4)$
 42. Convert to a logarithmic equation: $e^4 = t$.
 43. Convert to an exponential equation: $\log 0.001 = -3$.

Synthesis

44. Find a , to the nearest tenth.

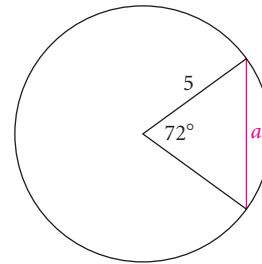

45. Find h , to the nearest tenth.

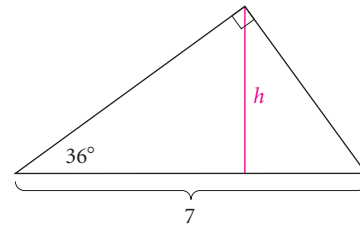

46. **Diameter of a Pipe.** A V-gauge is used to find the diameter of a pipe. The advantage of such a device is that it is rugged, it is accurate, and it has no moving parts to break down. In the figure, the measure of angle AVB is 54° . A pipe is placed in the V-shaped slot and the distance VP is used to estimate the diameter. The line VP is calibrated by listing as its units the corresponding diameters. This, in effect, establishes a function between VP and d .

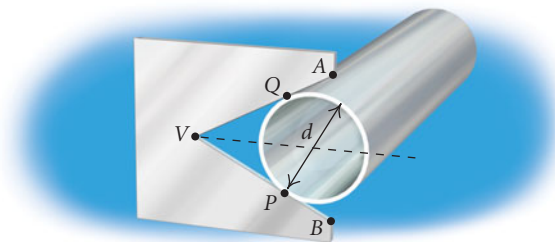

- a) Suppose that the diameter of a pipe is 2 cm. What is the distance VP ?

- b) Suppose that the distance VP is 3.93 cm. What is the diameter of the pipe?
- c) Find a formula for d in terms of VP .
- d) Find a formula for VP in terms of d .
47. **Sound of an Airplane.** It is common experience to hear the sound of a low-flying airplane and look at the wrong place in the sky to see the plane. Suppose that a plane is traveling directly at you at a speed of 200 mph and an altitude of 3000 ft, and you hear the sound at what seems to be an angle of inclination of 20° . At what angle θ should you actually look in order to see the plane? Consider the speed of sound to be 1100 ft/sec.

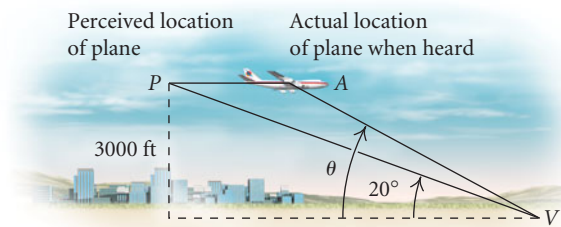

48. **Measuring the Radius of the Earth.** One way to measure the radius of the earth is to climb to the top of a mountain whose height above sea level is known and measure the angle between a vertical line to the center of the earth from the top of the mountain and a line drawn from the top of the mountain to the horizon, as shown in the figure. The height of Mt. Shasta in California is 14,162 ft. From the top of Mt. Shasta, one can see the horizon on the Pacific Ocean. The angle formed between a line to the horizon and the vertical is found to be $87^\circ 53'$. Use this information to estimate the radius of the earth, in miles.

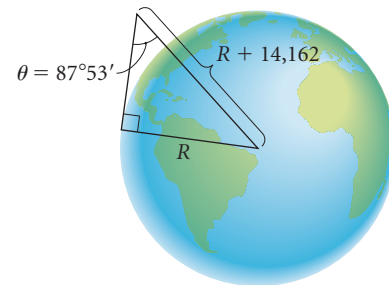

Trigonometric Functions of Any Angle

6.3

- ▶ Find angles that are coterminal with a given angle and find the complement and the supplement of a given angle.
- ▶ Determine the six trigonometric function values for any angle in standard position when the coordinates of a point on the terminal side are given.
- ▶ Find the function values for any angle whose terminal side lies on an axis.
- ▶ Find the function values for an angle whose terminal side makes an angle of 30° , 45° , or 60° with the x -axis.
- ▶ Use a calculator to find function values and angles.

▶ Angles, Rotations, and Degree Measure

An *angle* is a familiar figure in the world around us.



An **angle** is the union of two rays with a common endpoint called the **vertex**. In trigonometry, we often think of an angle as a **rotation**. To do so, think of locating a ray along the positive x -axis with its endpoint at the origin. This ray is called the **initial side** of the angle. Though we leave that ray fixed, think of making a copy of it and rotating it. A rotation *counterclockwise* is a **positive rotation**, and a rotation *clockwise* is a **negative rotation**. The ray at the end of the rotation is called the **terminal side** of the angle. The angle formed is said to be in **standard position**.

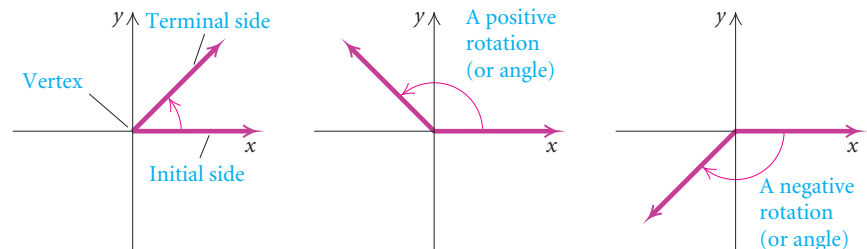

The measure of an angle or rotation may be given in degrees. The Babylonians developed the idea of dividing the circumference of a circle into 360 equal parts, or degrees. If we let the measure of one of these parts be 1° , then one complete positive revolution or rotation has a measure of 360° . One half of a revolution has a measure of 180° , one fourth of a revolution has a measure of 90° , and so on. We can also speak of an angle of measure 60° , 135° , 330° , or 420° . The terminal sides of these angles lie in quadrants I, II, IV, and I, respectively. The negative rotations -30° , -110° , and -225° represent angles with terminal sides in quadrants IV, III, and II, respectively.

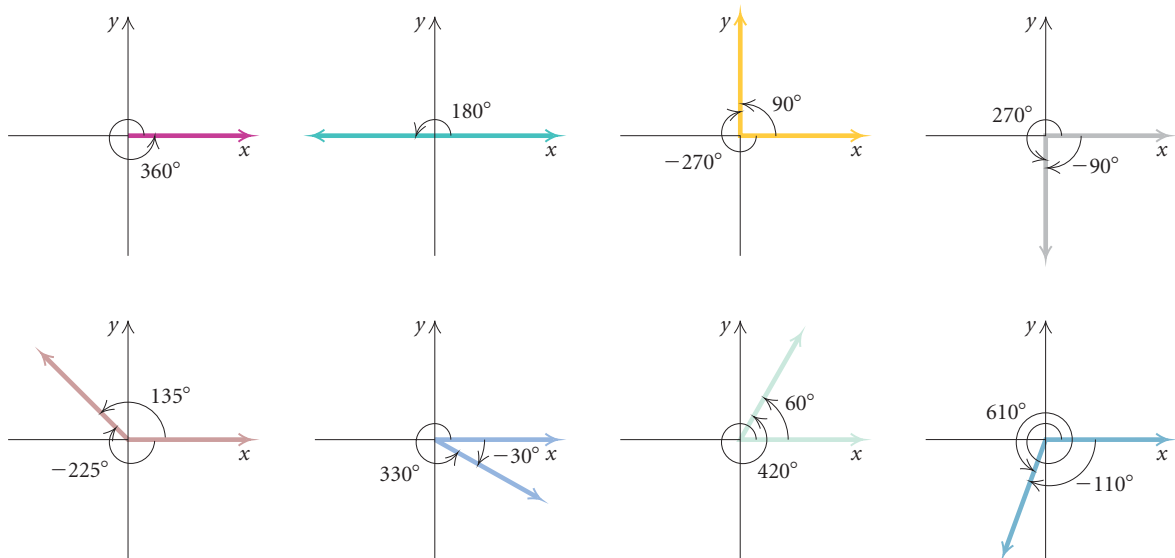

If two or more angles have the same terminal side, the angles are said to be **coterminal**. To find angles coterminal with a given angle, we add or subtract multiples of 360° . For example, 420° , shown above, has the same terminal side as 60° , since $420^\circ = 60^\circ + 360^\circ$. Thus we say that angles of measure 60° and 420° are coterminal. The negative rotation that measures -300° is also

coterminal with 60° because $60^\circ - 360^\circ = -300^\circ$. The set of all angles coterminal with 60° can be expressed as $60^\circ + n \cdot 360^\circ$, where n is an integer. Other examples of coterminal angles shown on the preceding page are 90° and -270° , -90° and 270° , 135° and -225° , -30° and 330° , and -110° and 610° .

EXAMPLE 1 Find two positive angles and two negative angles that are coterminal with (a) 51° and (b) -7° .

Solution

a) We add and subtract multiples of 360° . Many answers are possible.

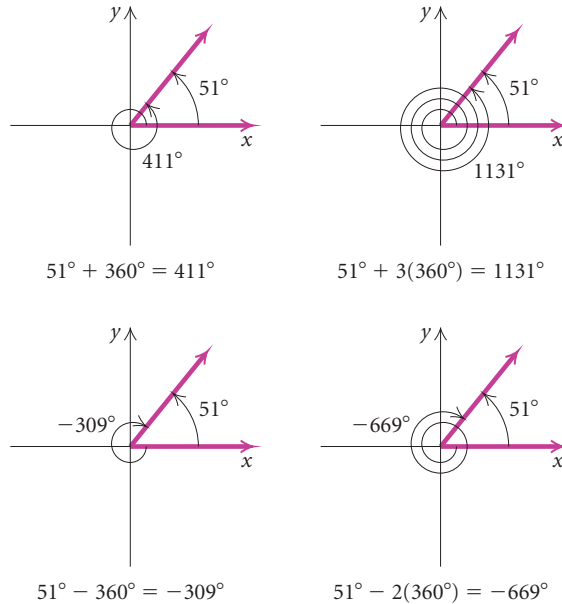

Thus angles of measure 411° , 1131° , -309° , and -669° are coterminal with 51° .

b) We have the following:

$$\begin{aligned}
 -7^\circ + 360^\circ &= 353^\circ, & -7^\circ + 2(360^\circ) &= 713^\circ, \\
 -7^\circ - 360^\circ &= -367^\circ, & -7^\circ - 10(360^\circ) &= -3607^\circ.
 \end{aligned}$$

Thus angles of measure 353° , 713° , -367° , and -3607° are coterminal with -7° .

Now Try Exercise 13.

Angles can be classified by their measures, as seen in the following figures.

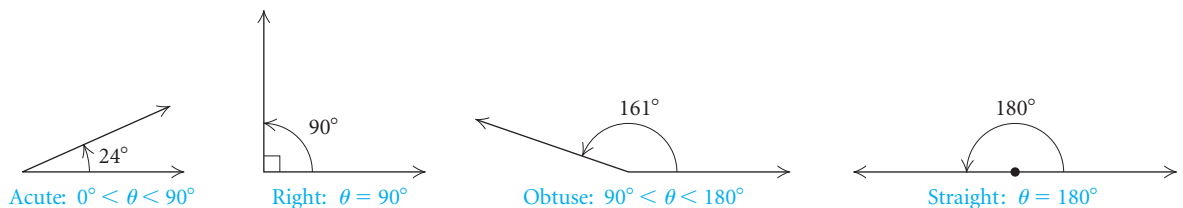

Recall that two *acute* angles are **complementary** if their sum is 90° . For example, angles that measure 10° and 80° are complementary because $10^\circ + 80^\circ = 90^\circ$. Two positive angles are **supplementary** if their sum is 180° . For example, angles that measure 45° and 135° are supplementary because $45^\circ + 135^\circ = 180^\circ$.

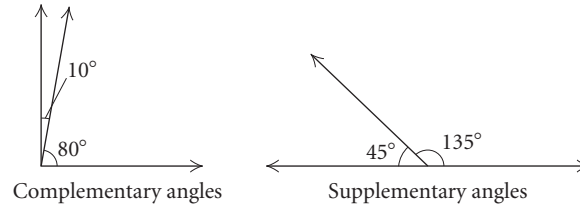

EXAMPLE 2 Find the complement and the supplement of 71.46° .

Solution We have

$$90^\circ - 71.46^\circ = 18.54^\circ \quad \text{and} \quad 180^\circ - 71.46^\circ = 108.54^\circ.$$

Thus the complement of 71.46° is 18.54° , and the supplement is 108.54° .

Now Try Exercise 19.

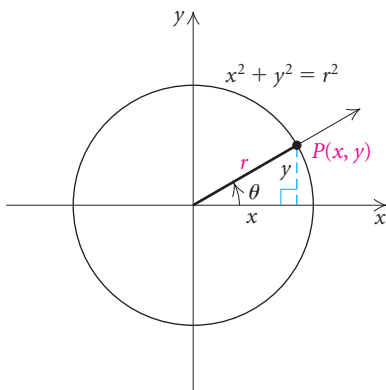

► Trigonometric Functions of Angles or Rotations

Many applied problems in trigonometry involve the use of angles that are not acute. Thus we need to extend the domains of the trigonometric functions defined in Section 6.1 to angles, or rotations, of *any* size. To do this, we first consider a right triangle with one vertex at the origin of a coordinate system and one vertex *on the positive x-axis*. (See the figure at left.) The other vertex is at P , a point on the circle whose center is at the origin and whose radius r is the length of the hypotenuse of the triangle. This triangle is a **reference triangle** for angle θ , which is in standard position. Note that y is the length of the side opposite θ and x is the length of the side adjacent to θ .

Recalling the definitions in Section 6.1, we note that three of the trigonometric functions of angle θ are defined as follows:

$$\sin \theta = \frac{\text{opp}}{\text{hyp}} = \frac{y}{r}, \quad \cos \theta = \frac{\text{adj}}{\text{hyp}} = \frac{x}{r}, \quad \tan \theta = \frac{\text{opp}}{\text{adj}} = \frac{y}{x}.$$

Since x and y are the coordinates of the point P and the length of the radius is the length of the hypotenuse, we can also define these functions as follows:

$$\sin \theta = \frac{y\text{-coordinate}}{\text{radius}},$$

$$\cos \theta = \frac{x\text{-coordinate}}{\text{radius}},$$

$$\tan \theta = \frac{y\text{-coordinate}}{x\text{-coordinate}}.$$

We will use these definitions for functions of angles of any measure. The following figures show angles whose terminal sides lie in quadrants II, III, and IV.

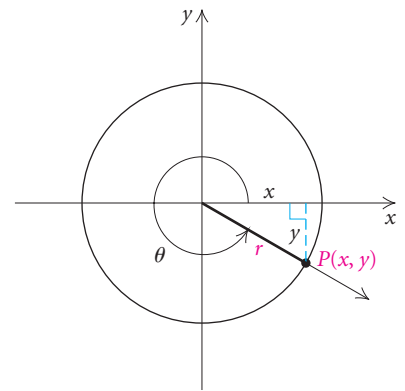
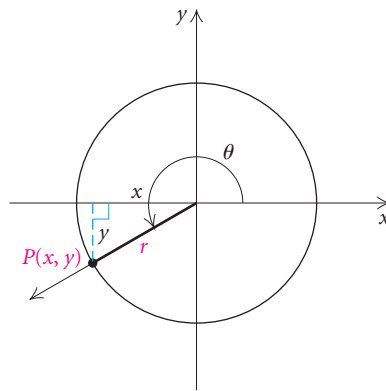
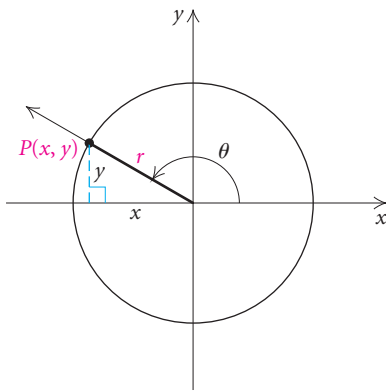

A reference triangle can be drawn for angles in any quadrant, as shown. Note that the angle is in standard position; that is, it is always measured from the positive half of the x -axis. The point $P(x, y)$ is a point, other than the vertex, on the terminal side of the angle. Each of its two coordinates may be positive, negative, or zero, depending on the location of the terminal side. *The length of the radius, which is also the length of the hypotenuse of the reference triangle, is always considered positive.* (Note that $x^2 + y^2 = r^2$, or $r = \sqrt{x^2 + y^2}$.) Regardless of the location of P , we have the following definitions.

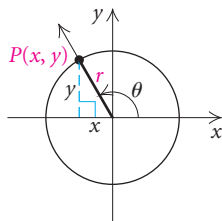

Trigonometric Functions of Any Angle θ

Suppose that $P(x, y)$ is any point other than the vertex on the terminal side of any angle θ in standard position, and r is the radius, or distance from the origin to $P(x, y)$. Then the trigonometric functions are defined as follows:

$$\sin \theta = \frac{y\text{-coordinate}}{\text{radius}} = \frac{y}{r}, \quad \csc \theta = \frac{\text{radius}}{y\text{-coordinate}} = \frac{r}{y},$$

$$\cos \theta = \frac{x\text{-coordinate}}{\text{radius}} = \frac{x}{r}, \quad \sec \theta = \frac{\text{radius}}{x\text{-coordinate}} = \frac{r}{x},$$

$$\tan \theta = \frac{y\text{-coordinate}}{x\text{-coordinate}} = \frac{y}{x}, \quad \cot \theta = \frac{x\text{-coordinate}}{y\text{-coordinate}} = \frac{x}{y}.$$

Values of the trigonometric functions can be positive, negative, or zero, depending on where the terminal side of the angle lies. The length of the radius is always positive. Thus the signs of the function values depend only on the coordinates of the point P on the terminal side of the angle. In the first quadrant, all function values are positive because both coordinates are positive. In the second quadrant, first coordinates are negative and second coordinates are positive; thus only the sine and the cosecant values are positive. Similarly, we can determine the signs of the function values in the third and

the fourth quadrants. *Because of the reciprocal relationships, we need learn only the signs for the sine, cosine, and tangent functions.*

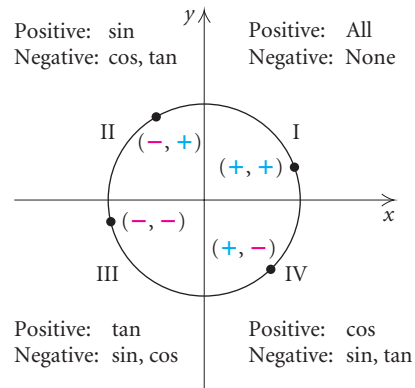

EXAMPLE 3 Find the six trigonometric function values for each angle shown.

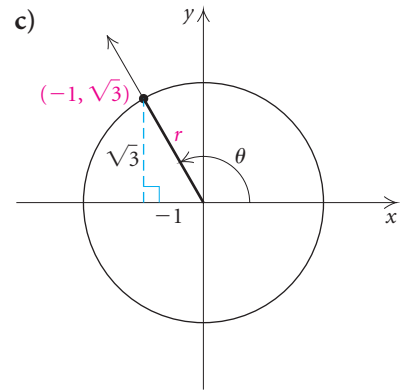
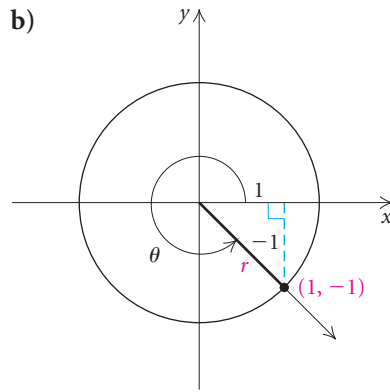
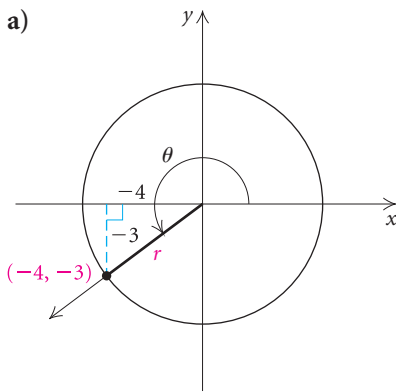

Solution

- a) We first determine r , the distance from the origin $(0, 0)$ to the point $(-4, -3)$. The distance between $(0, 0)$ and any point (x, y) on the terminal side of the angle is

$$r = \sqrt{(x - 0)^2 + (y - 0)^2} = \sqrt{x^2 + y^2}.$$

Substituting -4 for x and -3 for y , we find

$$r = \sqrt{(-4)^2 + (-3)^2} = \sqrt{16 + 9} = \sqrt{25} = 5.$$

Using the definitions of the trigonometric functions, we can now find the function values of θ . We substitute -4 for x , -3 for y , and 5 for r :

$$\sin \theta = \frac{y}{r} = \frac{-3}{5} = -\frac{3}{5}, \quad \csc \theta = \frac{r}{y} = \frac{5}{-3} = -\frac{5}{3},$$

$$\cos \theta = \frac{x}{r} = \frac{-4}{5} = -\frac{4}{5}, \quad \sec \theta = \frac{r}{x} = \frac{5}{-4} = -\frac{5}{4},$$

$$\tan \theta = \frac{y}{x} = \frac{-3}{-4} = \frac{3}{4}, \quad \cot \theta = \frac{x}{y} = \frac{-4}{-3} = \frac{4}{3}.$$

As expected, the tangent value and the cotangent value are positive and the other four are negative. This is true for all angles in quadrant III.

b) We first determine r , the distance from the origin to the point $(1, -1)$:

$$r = \sqrt{1^2 + (-1)^2} = \sqrt{1 + 1} = \sqrt{2}.$$

Substituting 1 for x , -1 for y , and $\sqrt{2}$ for r , we find

$$\sin \theta = \frac{y}{r} = \frac{-1}{\sqrt{2}} = -\frac{\sqrt{2}}{2}, \quad \csc \theta = \frac{r}{y} = \frac{\sqrt{2}}{-1} = -\sqrt{2},$$

$$\cos \theta = \frac{x}{r} = \frac{1}{\sqrt{2}} = \frac{\sqrt{2}}{2}, \quad \sec \theta = \frac{r}{x} = \frac{\sqrt{2}}{1} = \sqrt{2},$$

$$\tan \theta = \frac{y}{x} = \frac{-1}{1} = -1, \quad \cot \theta = \frac{x}{y} = \frac{1}{-1} = -1.$$

c) We determine r , the distance from the origin to the point $(-1, \sqrt{3})$:

$$r = \sqrt{(-1)^2 + (\sqrt{3})^2} = \sqrt{1 + 3} = \sqrt{4} = 2.$$

Substituting -1 for x , $\sqrt{3}$ for y , and 2 for r , we find that the trigonometric function values of θ are

$$\sin \theta = \frac{\sqrt{3}}{2}, \quad \csc \theta = \frac{2}{\sqrt{3}} = \frac{2\sqrt{3}}{3},$$

$$\cos \theta = \frac{-1}{2} = -\frac{1}{2}, \quad \sec \theta = \frac{2}{-1} = -2,$$

$$\tan \theta = \frac{\sqrt{3}}{-1} = -\sqrt{3}, \quad \cot \theta = \frac{-1}{\sqrt{3}} = -\frac{\sqrt{3}}{3}.$$

 **Now Try Exercise 27.**

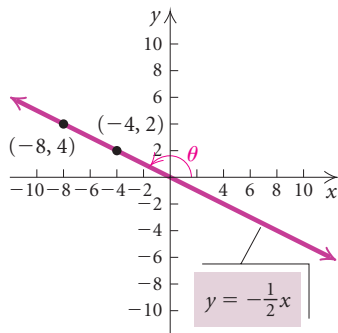

Any point other than the origin on the terminal side of an angle in standard position can be used to determine the trigonometric function values of that angle. The function values are the same regardless of which point is used. To illustrate this, let's consider an angle θ in standard position whose terminal side lies on the line $y = -\frac{1}{2}x$. We can determine two second-quadrant solutions of the equation, find the length r for each point, and then compare the sine, cosine, and tangent function values using each point.

$$\text{If } x = -4, \text{ then } y = -\frac{1}{2}(-4) = 2.$$

$$\text{If } x = -8, \text{ then } y = -\frac{1}{2}(-8) = 4.$$

$$\text{For } (-4, 2), r = \sqrt{(-4)^2 + 2^2} = \sqrt{20} = 2\sqrt{5}.$$

$$\text{For } (-8, 4), r = \sqrt{(-8)^2 + 4^2} = \sqrt{80} = 4\sqrt{5}.$$

Using $(-4, 2)$ and $r = 2\sqrt{5}$, we find that

$$\sin \theta = \frac{2}{2\sqrt{5}} = \frac{1}{\sqrt{5}} = \frac{\sqrt{5}}{5},$$

$$\cos \theta = \frac{-4}{2\sqrt{5}} = \frac{-2}{\sqrt{5}} = -\frac{2\sqrt{5}}{5},$$

$$\text{and } \tan \theta = \frac{2}{-4} = -\frac{1}{2}.$$

Using $(-8, 4)$ and $r = 4\sqrt{5}$, we find that

$$\sin \theta = \frac{4}{4\sqrt{5}} = \frac{1}{\sqrt{5}} = \frac{\sqrt{5}}{5},$$

$$\cos \theta = \frac{-8}{4\sqrt{5}} = \frac{-2}{\sqrt{5}} = -\frac{2\sqrt{5}}{5},$$

and $\tan \theta = \frac{4}{-8} = -\frac{1}{2}.$

We see that the function values are the same using either point. Any point other than the origin on the terminal side of an angle can be used to determine the trigonometric function values.

The trigonometric function values of θ depend only on the angle, not on the choice of the point on the terminal side that is used to compute them.

► The Six Functions Related

When we know one of the function values of an angle, we can find the other five if we know the quadrant in which the terminal side lies. The procedure is to sketch a reference triangle in the appropriate quadrant, use the Pythagorean equation as needed to find the lengths of its sides, and then find the ratios of the sides.

EXAMPLE 4 Given that $\tan \theta = -\frac{2}{3}$ and θ is in the second quadrant, find the other function values.

Solution We first sketch a second-quadrant angle. Since

$$\tan \theta = \frac{y}{x} = -\frac{2}{3} = \frac{2}{-3}, \quad \text{Expressing } -\frac{2}{3} \text{ as } \frac{2}{-3} \text{ since } \theta \text{ is in quadrant II}$$

we make the legs lengths 2 and 3. The hypotenuse must then have length $\sqrt{2^2 + 3^2}$, or $\sqrt{13}$. Now we read off the appropriate ratios:

$$\sin \theta = \frac{2}{\sqrt{13}}, \quad \text{or} \quad \frac{2\sqrt{13}}{13}, \quad \csc \theta = \frac{\sqrt{13}}{2},$$

$$\cos \theta = -\frac{3}{\sqrt{13}}, \quad \text{or} \quad -\frac{3\sqrt{13}}{13}, \quad \sec \theta = -\frac{\sqrt{13}}{3},$$

$$\tan \theta = -\frac{2}{3}, \quad \cot \theta = -\frac{3}{2}.$$

► Now Try Exercise 33.

► Terminal Side on an Axis

An angle whose terminal side falls on one of the axes is a **quadrantal angle**. One of the coordinates of any point on that side is 0. The definitions of the trigonometric functions still apply, but in some cases, function values will not be defined because a denominator will be 0.

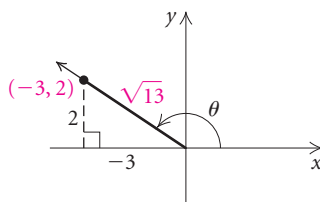

EXAMPLE 5 Find the sine, cosine, and tangent values for 90° , 180° , 270° , and 360° .

Solution We first make a drawing of each angle in standard position and label a point on the terminal side. Since the function values are the same for all points on the terminal side, we choose $(0, 1)$, $(-1, 0)$, $(0, -1)$, and $(1, 0)$ for convenience. Note that $r = 1$ for each choice.

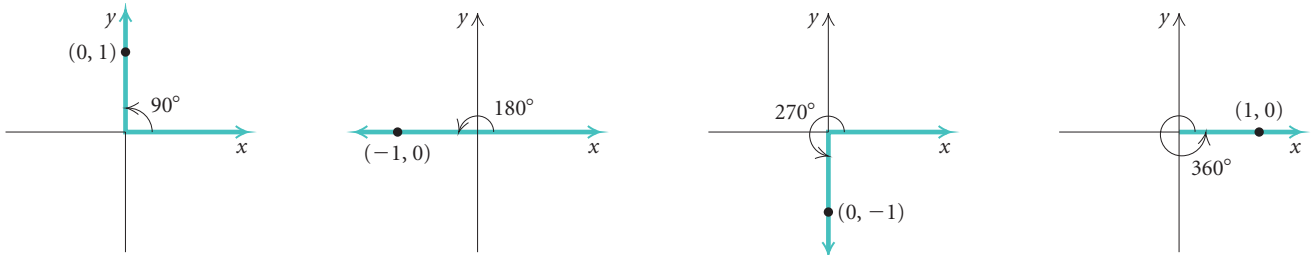

Then by the definitions we get

$$\sin 90^\circ = \frac{1}{1} = 1,$$

$$\cos 90^\circ = \frac{0}{1} = 0,$$

$$\tan 90^\circ = \frac{1}{0}, \text{ Not defined}$$

$$\sin 180^\circ = \frac{0}{1} = 0,$$

$$\cos 180^\circ = \frac{-1}{1} = -1,$$

$$\tan 180^\circ = \frac{0}{-1} = 0,$$

$$\sin 270^\circ = \frac{-1}{1} = -1,$$

$$\cos 270^\circ = \frac{0}{1} = 0,$$

$$\tan 270^\circ = \frac{-1}{0}, \text{ Not defined}$$

$$\sin 360^\circ = \frac{0}{1} = 0,$$

$$\cos 360^\circ = \frac{1}{1} = 1,$$

$$\tan 360^\circ = \frac{0}{1} = 0.$$



TECHNOLOGY CONNECTION

Trigonometric values can always be checked using a calculator. When the value is undefined, the calculator will display an ERROR message.

ERR: DIVIDE BY 0

1: Quit
2: Goto

or

ERR: DOMAIN

1: Quit
2: Goto

In Example 5, all the values can be found using a calculator, but you will find that it is convenient to be able to compute them mentally. It is also helpful to note that coterminal angles have the same function values. For example, 0° and 360° are coterminal; thus, $\sin 0^\circ = 0$, $\cos 0^\circ = 1$, and $\tan 0^\circ = 0$.

EXAMPLE 6 Find each of the following.

a) $\sin(-90^\circ)$

b) $\csc 540^\circ$

Solution

a) We note that -90° is coterminal with 270° . Thus,

$$\sin(-90^\circ) = \sin 270^\circ = \frac{-1}{1} = -1.$$

b) Since $540^\circ = 180^\circ + 360^\circ$, 540° and 180° are coterminal. Thus,

$$\csc 540^\circ = \csc 180^\circ = \frac{1}{\sin 180^\circ} = \frac{1}{0}, \text{ which is not defined.}$$

Now Try Exercises 43 and 53.

► Reference Angles: 30° , 45° , and 60°

We can also mentally determine trigonometric function values whenever the terminal side makes a 30° , 45° , or 60° angle with the x -axis. Consider, for example, an angle of 150° . The terminal side makes a 30° angle with the x -axis, since $180^\circ - 150^\circ = 30^\circ$.

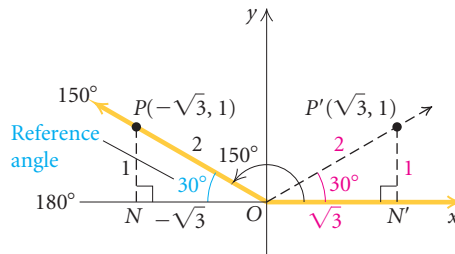

As the figure shows, $\triangle ONP$ is congruent to $\triangle ON'P'$; therefore, the ratios of the sides of the two triangles are the same. Thus the trigonometric function values are the same except perhaps for the sign. We could determine the function values directly from $\triangle ONP$, but this is not necessary. If we remember that in quadrant II, the sine is positive and the cosine and the tangent are negative, we can simply use the function values of 30° that we already know and prefix the appropriate sign. Thus,

$$\sin 150^\circ = \sin 30^\circ = \frac{1}{2},$$

$$\cos 150^\circ = -\cos 30^\circ = -\frac{\sqrt{3}}{2},$$

$$\text{and } \tan 150^\circ = -\tan 30^\circ = -\frac{1}{\sqrt{3}}, \text{ or } -\frac{\sqrt{3}}{3}.$$

Triangle ONP is the reference triangle, and the acute angle $\angle NOP$ is called a *reference angle*.

Reference Angle

The **reference angle** for an angle is the acute angle formed by the terminal side of the angle and the x -axis.

EXAMPLE 7 Find the sine, cosine, and tangent function values for each of the following.

a) 225°

b) -780°

Solution

- a) We draw a figure showing the terminal side of a 225° angle. The reference angle is $225^\circ - 180^\circ$, or 45° .

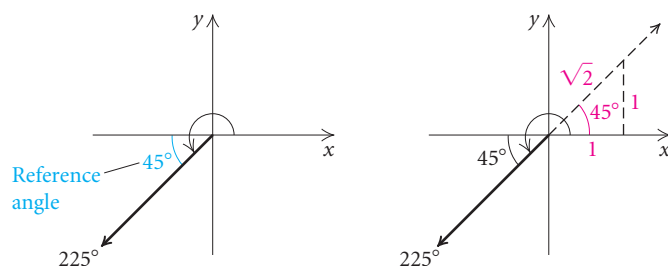

Recall from Section 6.1 that $\sin 45^\circ = \sqrt{2}/2$, $\cos 45^\circ = \sqrt{2}/2$, and $\tan 45^\circ = 1$. Also note that in the third quadrant, the sine and the cosine are negative and the tangent is positive. Thus we have

$$\sin 225^\circ = -\frac{\sqrt{2}}{2}, \quad \cos 225^\circ = -\frac{\sqrt{2}}{2}, \quad \text{and} \quad \tan 225^\circ = 1.$$

- b) We draw a figure showing the terminal side of a -780° angle. Since $-780^\circ + 2(360^\circ) = -60^\circ$, we know that -780° and -60° are coterminal.

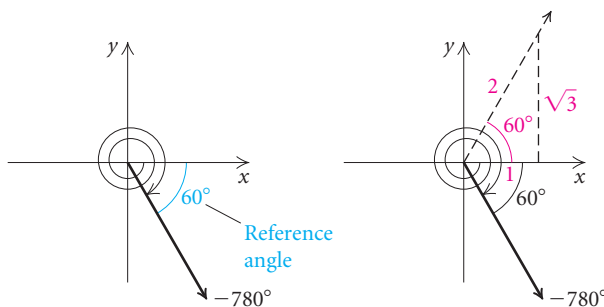

The reference angle for -60° is the acute angle formed by the terminal side of the angle and the x -axis. Thus the reference angle for -60° is 60° . We know that since -780° is a fourth-quadrant angle, the cosine is positive and the sine and the tangent are negative. Recalling that $\sin 60^\circ = \sqrt{3}/2$, $\cos 60^\circ = 1/2$, and $\tan 60^\circ = \sqrt{3}$, we have

$$\sin(-780^\circ) = -\frac{\sqrt{3}}{2},$$

$$\cos(-780^\circ) = \frac{1}{2},$$

and $\tan(-780^\circ) = -\sqrt{3}.$

 **Now Try Exercises 45 and 49.**

TECHNOLOGY CONNECTION

To find trigonometric function values of angles measured in degrees, we set the calculator in DEGREE mode. In the windows below, parts (a)–(f) of Example 8 are shown.

$\cos(112)$	$-.3746065934$
$1/\cos(500)$	-1.305407289
$\tan(-83.4)$	-8.642747461

$1/\sin(351.75)$	-6.968999424
$\cos(2400)$	$-.5$
$\sin(175^\circ 40' 9'')$	$.0755153443$

► Function Values for Any Angle

When the terminal side of an angle falls on one of the axes or makes a 30° , 45° , or 60° angle with the x -axis, we can find exact function values without the use of a calculator. But this group is only a small subset of *all* angles. Using a calculator, we can approximate the trigonometric function values of *any* angle. In fact, we can approximate or find exact function values of all angles without using a reference angle.

EXAMPLE 8 Find each of the following function values using a calculator and round the answer to four decimal places, where appropriate.

- | | |
|------------------------|-----------------------------|
| a) $\cos 112^\circ$ | b) $\sec 500^\circ$ |
| c) $\tan(-83.4^\circ)$ | d) $\csc 351.75^\circ$ |
| e) $\cos 2400^\circ$ | f) $\sin 175^\circ 40' 9''$ |
| g) $\cot(-135^\circ)$ | |

Solution Using a calculator set in DEGREE mode, we find the values.

- a) $\cos 112^\circ \approx -0.3746$
- b) $\sec 500^\circ = \frac{1}{\cos 500^\circ} \approx -1.3054$
- c) $\tan(-83.4^\circ) \approx -8.6427$
- d) $\csc 351.75^\circ = \frac{1}{\sin 351.75^\circ} \approx -6.9690$
- e) $\cos 2400^\circ = -0.5$
- f) $\sin 175^\circ 40' 9'' \approx 0.0755$
- g) $\cot(-135^\circ) = \frac{1}{\tan(-135^\circ)} = 1$

 **Now Try Exercises 87 and 93.**

In many applications, we have a trigonometric function value and want to find the measure of a corresponding angle. When only acute angles are considered, there is only one angle for each trigonometric function value. This is not the case when we extend the domain of the trigonometric functions to the set of *all* angles. For a given function value, there is an infinite number of angles that have that function value. There can be two such angles for each value in the range from 0° to 360° . To determine a unique answer in the interval $(0^\circ, 360^\circ)$, the quadrant in which the terminal side lies must be specified.

The calculator gives the reference angle as an output for each function value that is entered as an input. Knowing the reference angle and the quadrant in which the terminal side lies, we can find the specified angle.

EXAMPLE 9 Given the function value and the quadrant restriction, find θ .

- a) $\sin \theta = 0.2812$, $90^\circ < \theta < 180^\circ$
- b) $\cot \theta = -0.1611$, $270^\circ < \theta < 360^\circ$

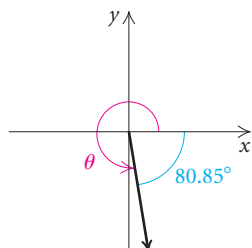
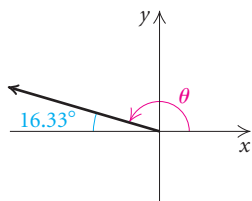
**Solution**

- a) We first sketch the angle in the second quadrant. We use the calculator to find the acute angle (reference angle) whose sine is 0.2812. The reference angle is approximately 16.33° . We find the angle θ by subtracting 16.33° from 180° :

$$180^\circ - 16.33^\circ = 163.67^\circ.$$

Thus, $\theta \approx 163.67^\circ$.

- b) We begin by sketching the angle in the fourth quadrant. Because the tangent and cotangent values are reciprocals, we know that

$$\tan \theta \approx \frac{1}{-0.1611} \approx -6.2073.$$

We use the calculator to find the acute angle (reference angle) whose tangent is 6.2073, ignoring the fact that θ is negative. The reference angle is approximately 80.85° . We find angle θ by subtracting 80.85° from 360° :

$$360^\circ - 80.85^\circ = 279.15^\circ.$$

Thus, $\theta \approx 279.15^\circ$.

Now Try Exercise 99.

Bearing: Second-Type. In aerial navigation, directions are given in degrees clockwise from north. Thus east is 90° , south is 180° , and west is 270° . Several aerial directions, or **bearings**, are given below.

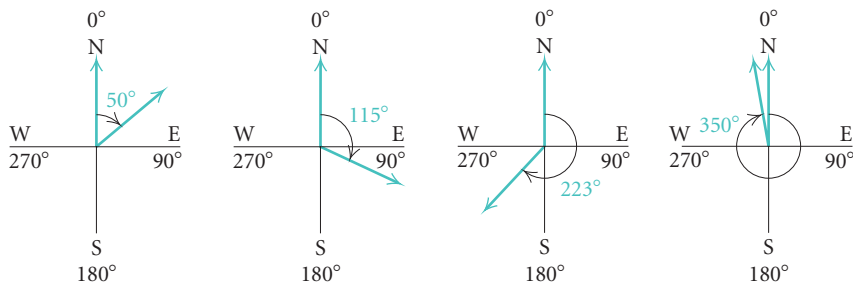

EXAMPLE 10 Aerial Navigation. An airplane flies 218 mi from an airport in a direction of 245° . How far south of the airport is the plane then? How far west?

Solution We first find the measure of $\angle ABC$:

$$\angle ABC = 270^\circ - 245^\circ = 25^\circ.$$

From the figure shown at left, we see that the distance south of the airport b and the distance west of the airport a are parts of a right triangle. We have

$$\frac{b}{218} = \sin 25^\circ$$

$$b = 218 \sin 25^\circ \approx 92 \text{ mi}$$

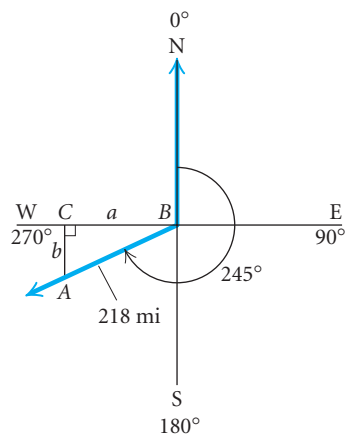

and

$$\frac{a}{218} = \cos 25^\circ$$

$$a = 218 \cos 25^\circ \approx 198 \text{ mi.}$$

The airplane is about 92 mi south and about 198 mi west of the airport.

 **Now Try Exercise 83.**

6.3

Exercise Set

For angles of the following measures, state in which quadrant the terminal side lies. It helps to sketch the angle in standard position.

- | | |
|--------------------|-------------------------|
| 1. 187° | 2. -14.3° |
| 3. $245^\circ 15'$ | 4. -120° |
| 5. 800° | 6. 1075° |
| 7. -460.5° | 8. 315° |
| 9. -912° | 10. $13^\circ 15' 58''$ |
| 11. 537° | 12. -345.14° |

Find two positive angles and two negative angles that are coterminal with the given angle. Answers may vary.

- | | |
|-------------------|---------------------|
| 13. 74° | 14. -81° |
| 15. 115.3° | 16. $275^\circ 10'$ |
| 17. -180° | 18. -310° |

Find the complement and the supplement.

- | | |
|------------------------|--------------------|
| 19. 17.11° | 20. $47^\circ 38'$ |
| 21. $12^\circ 3' 14''$ | 22. 9.038° |
| 23. 45.2° | 24. 67.31° |

Find the six trigonometric function values for the angle shown.

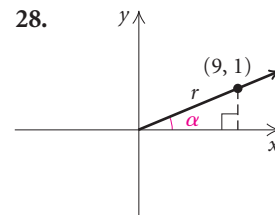
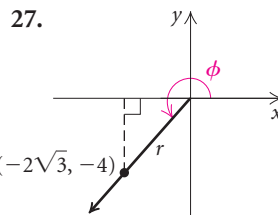
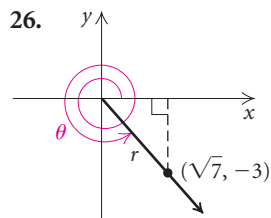
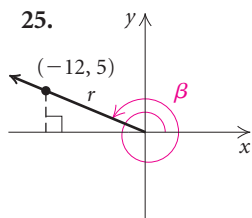

The terminal side of angle θ in standard position lies on the given line in the given quadrant. Find $\sin \theta$, $\cos \theta$, and $\tan \theta$.

29. $2x + 3y = 0$; quadrant IV
 30. $4x + y = 0$; quadrant II
 31. $5x - 4y = 0$; quadrant I
 32. $y = 0.8x$; quadrant III

A function value and a quadrant are given. Find the other five function values. Give exact answers.

33. $\sin \theta = -\frac{1}{3}$; quadrant III
 34. $\tan \beta = 5$; quadrant I
 35. $\cot \theta = -2$; quadrant IV
 36. $\cos \alpha = -\frac{4}{5}$; quadrant II
 37. $\cos \phi = \frac{3}{5}$; quadrant IV
 38. $\sin \theta = -\frac{5}{13}$; quadrant III

Find the reference angle and the exact function value if it exists.

- | | |
|------------------------|------------------------|
| 39. $\cos 150^\circ$ | 40. $\sec(-225^\circ)$ |
| 41. $\tan(-135^\circ)$ | 42. $\sin(-45^\circ)$ |
| 43. $\sin 7560^\circ$ | 44. $\tan 270^\circ$ |
| 45. $\cos 495^\circ$ | 46. $\tan 675^\circ$ |
| 47. $\csc(-210^\circ)$ | 48. $\sin 300^\circ$ |
| 49. $\cot 570^\circ$ | 50. $\cos(-120^\circ)$ |
| 51. $\tan 330^\circ$ | 52. $\cot 855^\circ$ |
| 53. $\sec(-90^\circ)$ | 54. $\sin 90^\circ$ |
| 55. $\cos(-180^\circ)$ | 56. $\csc 90^\circ$ |
| 57. $\tan 240^\circ$ | 58. $\cot(-180^\circ)$ |
| 59. $\sin 495^\circ$ | 60. $\sin 1050^\circ$ |
| 61. $\csc 225^\circ$ | 62. $\sin(-450^\circ)$ |
| 63. $\cos 0^\circ$ | 64. $\tan 480^\circ$ |
| 65. $\cot(-90^\circ)$ | 66. $\sec 315^\circ$ |
| 67. $\cos 90^\circ$ | 68. $\sin(-135^\circ)$ |
| 69. $\cos 270^\circ$ | 70. $\tan 0^\circ$ |

Find the signs of the six trigonometric function values for the given angles.

- | | |
|------------------|------------------|
| 71. 319° | 72. -57° |
| 73. 194° | 74. -620° |
| 75. -215° | 76. 290° |
| 77. -272° | 78. 91° |

Use a calculator in Exercises 79–82, but do not use the trigonometric function keys.

79. Given that

$$\begin{aligned}\sin 41^\circ &= 0.6561, \\ \cos 41^\circ &= 0.7547, \\ \tan 41^\circ &= 0.8693,\end{aligned}$$

find the trigonometric function values for 319° .

80. Given that

$$\begin{aligned}\sin 27^\circ &= 0.4540, \\ \cos 27^\circ &= 0.8910, \\ \tan 27^\circ &= 0.5095,\end{aligned}$$

find the trigonometric function values for 333° .

81. Given that

$$\begin{aligned}\sin 65^\circ &= 0.9063, \\ \cos 65^\circ &= 0.4226, \\ \tan 65^\circ &= 2.1445,\end{aligned}$$

find the trigonometric function values for 115° .

82. Given that

$$\begin{aligned}\sin 35^\circ &= 0.5736, \\ \cos 35^\circ &= 0.8192, \\ \tan 35^\circ &= 0.7002,\end{aligned}$$

find the trigonometric function values for 215° .

83. **Aerial Navigation.** An airplane flies 150 km from an airport in a direction of 120° . How far east of the airport is the plane then? How far south?

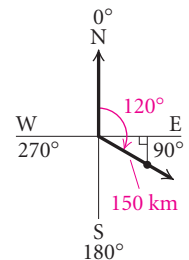

84. **Aerial Navigation.** An airplane leaves an airport and travels for 100 mi in a direction of 300° . How far north of the airport is the plane then? How far west?

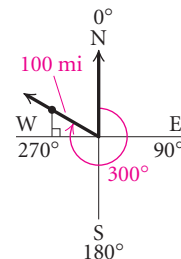

85. **Aerial Navigation.** An airplane travels at 150 km/h for 2 hr in a direction of 138° from Omaha. At the end of this time, how far south of Omaha is the plane?
86. **Aerial Navigation.** An airplane travels at 120 km/h for 2 hr in a direction of 319° from Chicago. At the end of this time, how far north of Chicago is the plane?

Find the function value. Round to four decimal places.

87. $\tan 310.8^\circ$ 88. $\cos 205.5^\circ$
 89. $\cot 146.15^\circ$ 90. $\sin (-16.4^\circ)$
 91. $\sin 118^\circ 42'$ 92. $\cos 273^\circ 45'$
 93. $\cos (-295.8^\circ)$ 94. $\tan 1086.2^\circ$
 95. $\cos 5417^\circ$ 96. $\sec 240^\circ 55'$
 97. $\csc 520^\circ$ 98. $\sin 3824^\circ$

Given the function value and the quadrant restriction, find θ .

Function Value	Interval	θ
99. $\sin \theta = -0.9956$	$(270^\circ, 360^\circ)$	
100. $\tan \theta = 0.2460$	$(180^\circ, 270^\circ)$	
101. $\cos \theta = -0.9388$	$(180^\circ, 270^\circ)$	
102. $\sec \theta = -1.0485$	$(90^\circ, 180^\circ)$	
103. $\tan \theta = -3.0545$	$(270^\circ, 360^\circ)$	
104. $\sin \theta = -0.4313$	$(180^\circ, 270^\circ)$	
105. $\csc \theta = 1.0480$	$(0^\circ, 90^\circ)$	
106. $\cos \theta = -0.0990$	$(90^\circ, 180^\circ)$	

Skill Maintenance

Graph the function. Sketch and label any vertical asymptotes.

107. $f(x) = \frac{1}{x^2 - 25}$ 108. $g(x) = x^3 - 2x + 1$

Determine the domain and the range of the function.

109. $f(x) = \frac{x - 4}{x + 2}$
 110. $g(x) = \frac{x^2 - 9}{2x^2 - 7x - 15}$

Find the zeros of the function.

111. $f(x) = 12 - x$ 112. $g(x) = x^2 - x - 6$

Find the x -intercepts of the graph of the function.

113. $f(x) = 12 - x$ 114. $g(x) = x^2 - x - 6$

Synthesis

115. **Valve Cap on a Bicycle.** The valve cap on a bicycle wheel is 12.5 in. from the center of the wheel. From the position shown, the wheel starts to roll. After the wheel has turned 390° , how far above the ground is the valve cap? Assume that the outer radius of the tire is 13.375 in.



116. **Seats of a Ferris Wheel.** The seats of a ferris wheel are 35 ft from the center of the wheel. When you board the wheel, you are 5 ft above the ground. After you have rotated through an angle of 765° , how far above the ground are you?



Mid-Chapter Mixed Review

Determine whether the statement is true or false.

- If $\sin \alpha > 0$ and $\cot \alpha > 0$, then α is in the first quadrant. [6.3]
- The lengths of corresponding sides in similar triangles are in the same ratio. [6.1]
- If θ is an acute angle and $\csc \theta \approx 1.5539$, then $\cos(90^\circ - \theta) \approx 0.6435$. [6.1]

Solve the right triangle. [6.2]

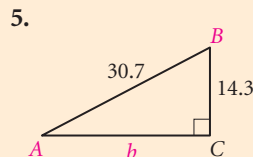
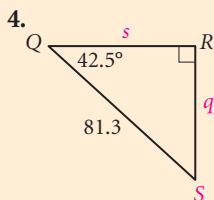

Find two positive angles and two negative angles that are coterminal with the given angle. Answers may vary. [6.3]

- -75°
- $214^\circ 30'$

Find the complement and the supplement of the given angle. [6.3]

- 18.2°
- $87^\circ 15' 10''$
- Given that $\sin 25^\circ = 0.4226$, $\cos 25^\circ = 0.9063$, and $\tan 25^\circ = 0.4663$, find the six trigonometric function values for 155° . Use a calculator, but do not use the trigonometric function keys. [6.3]
- Find the six trigonometric function values for the angle shown. [6.3]

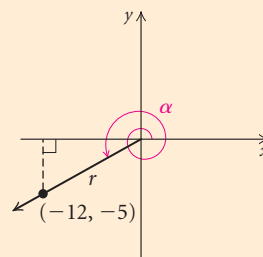

- Given $\cot \theta = 2$ and θ in quadrant III, find the other five function values. [6.3]
- Convert $42^\circ 08' 50''$ to decimal degree notation. Round to four decimal places. [6.1]
- Given that $\sin 9^\circ \approx 0.1564$, $\cos 9^\circ \approx 0.9877$, and $\tan 9^\circ \approx 0.1584$, find the six function values of 81° . [6.1]
- Aerial Navigation.** An airplane travels at 200 mph for $1\frac{1}{2}$ hr in a direction of 285° from Atlanta. At the end of this time, how far west of Atlanta is the plane? [6.3]
- Given $\cos \alpha = \frac{2}{9}$ and $0^\circ < \alpha < 90^\circ$, find the other five trigonometric function values. [6.1]
- Convert 51.18° to degrees, minutes, and seconds. [6.1]
- If $\tan \theta = 2.412$ and θ is acute, find the angle to the nearest tenth of a degree. [6.1]

Without a calculator, find the exact function value. [6.1], [6.3]

- | | | | |
|----------------------|-----------------------|------------------------|------------------------|
| 19. $\tan 210^\circ$ | 20. $\sin 45^\circ$ | 21. $\cot 30^\circ$ | 22. $\sec 135^\circ$ |
| 23. $\cos 45^\circ$ | 24. $\csc(-30^\circ)$ | 25. $\sin 90^\circ$ | 26. $\cos 270^\circ$ |
| 27. $\sin 120^\circ$ | 28. $\sec 180^\circ$ | 29. $\tan(-240^\circ)$ | 30. $\cot(-315^\circ)$ |
| 31. $\sin 750^\circ$ | 32. $\csc 45^\circ$ | 33. $\cos 210^\circ$ | 34. $\cot 0^\circ$ |
| 35. $\csc 150^\circ$ | 36. $\tan 90^\circ$ | 37. $\sec 3600^\circ$ | 38. $\cos 495^\circ$ |

Find the function value. Round the answer to four decimal places. [6.1], [6.3]

- | | | | |
|-----------------------|------------------------|-------------------------|------------------------------|
| 39. $\cos 39.8^\circ$ | 40. $\sec 50^\circ$ | 41. $\tan 2183^\circ$ | 42. $\sin 10^\circ 28' 03''$ |
| 43. $\csc(-74^\circ)$ | 44. $\cot 142.7^\circ$ | 45. $\sin(-40.1^\circ)$ | 46. $\cos 87^\circ 15'$ |

Collaborative Discussion and Writing

47. Why do the function values of θ depend only on the angle and not on the choice of a point on the terminal side? [6.3]
48. Explain the difference between reciprocal functions and cofunctions. [6.1]
49. In Section 6.1, the trigonometric functions are defined as functions of acute angles. What appear to be the ranges for the sine, cosine, and tangent functions given the restricted domain as the set of angles whose measures are greater than 0° and less than 90° ? [6.1]
50. Why is the domain of the tangent function different from the domains of the sine function and the cosine function? [6.3]

Radians, Arc Length, and Angular Speed

6.4

- ▶ Find points on the unit circle determined by real numbers.
- ▶ Convert between radian measure and degree measure; find coterminal, complementary, and supplementary angles.
- ▶ Find the length of an arc of a circle; find the measure of a central angle of a circle.
- ▶ Convert between linear speed and angular speed.

CIRCLES

REVIEW SECTION 1.1

Another useful unit of angle measure is called a *radian*. To introduce radian measure, we use a circle centered at the origin with a radius of length 1. Such a circle is called a **unit circle**. Its equation is $x^2 + y^2 = 1$.

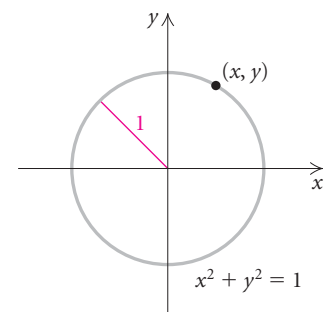

► Distances on the Unit Circle

The circumference of a circle of radius r is $2\pi r$. Thus for the unit circle, where $r = 1$, the circumference is 2π . If a point starts at A and travels around the circle (Fig. 1), it will travel a distance of 2π . If it travels halfway around the circle (Fig. 2), it will travel a distance of $\frac{1}{2} \cdot 2\pi$, or π .

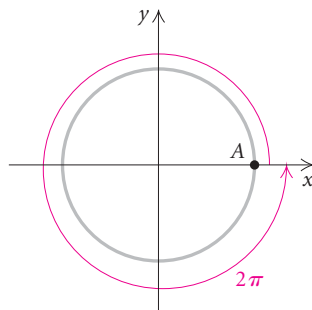

Figure 1

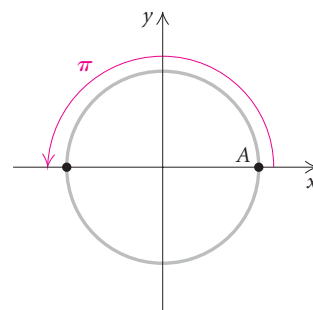

Figure 2

If a point C travels $\frac{1}{8}$ of the way around the circle (Fig. 3), it will travel a distance of $\frac{1}{8} \cdot 2\pi$, or $\pi/4$. Note that C is $\frac{1}{4}$ of the way from A to B . If a point D travels $\frac{1}{6}$ of the way around the circle (Fig. 4), it will travel a distance of $\frac{1}{6} \cdot 2\pi$, or $\pi/3$. Note that D is $\frac{1}{3}$ of the way from A to B .

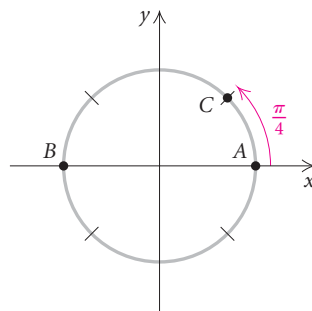

Figure 3

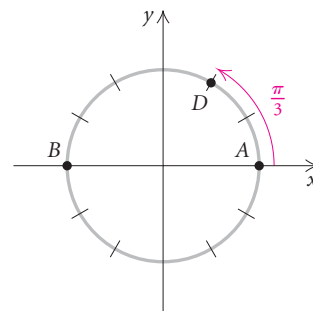

Figure 4

EXAMPLE 1 How far will a point travel if it goes (a) $\frac{1}{4}$, (b) $\frac{1}{12}$, (c) $\frac{3}{8}$, and (d) $\frac{5}{6}$ of the way around the unit circle?

Solution

- $\frac{1}{4}$ of the total distance around the circle is $\frac{1}{4} \cdot 2\pi$, which is $\frac{1}{2} \cdot \pi$, or $\pi/2$.
- The distance will be $\frac{1}{12} \cdot 2\pi$, which is $\frac{1}{6}\pi$, or $\pi/6$.
- The distance will be $\frac{3}{8} \cdot 2\pi$, which is $\frac{3}{4}\pi$, or $3\pi/4$.
- The distance will be $\frac{5}{6} \cdot 2\pi$, which is $\frac{5}{3}\pi$, or $5\pi/3$. Think of $5\pi/3$ as $\pi + \frac{2}{3}\pi$.

These distances are illustrated in the following figures.

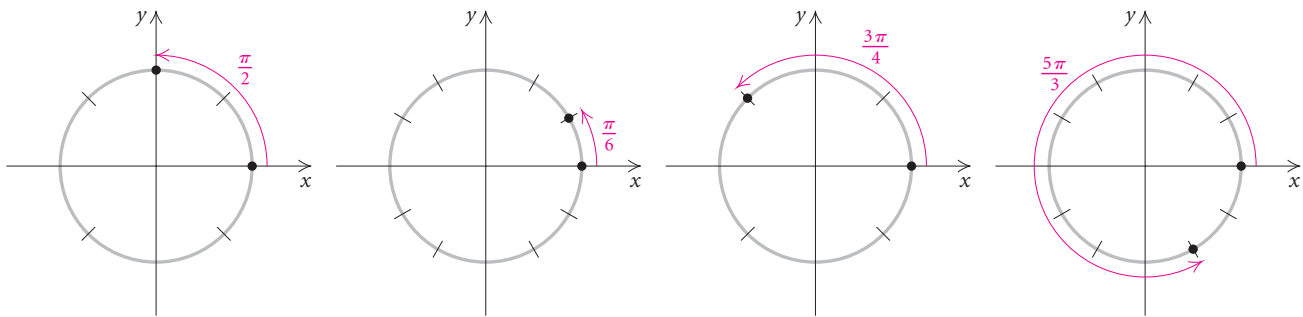

A point may travel completely around the circle and then continue. For example, if it goes around once and then continues $\frac{1}{4}$ of the way around, it will have traveled a distance of $2\pi + \frac{1}{4} \cdot 2\pi$, or $5\pi/2$ (Fig. 5). *Every* real number determines a point on the unit circle. For the positive number 10, for example, we start at A and travel counterclockwise a distance of 10. The point at which we stop is the point “determined” by the number 10. Note that $2\pi \approx 6.28$ and that $10 \approx 1.6(2\pi)$. Thus the point for 10 travels around the unit circle about $1\frac{3}{5}$ times (Fig. 6).

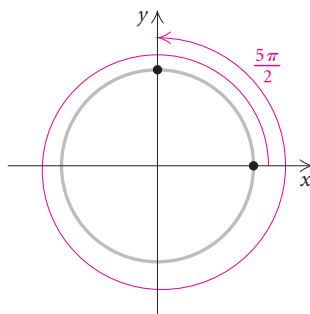

Figure 5

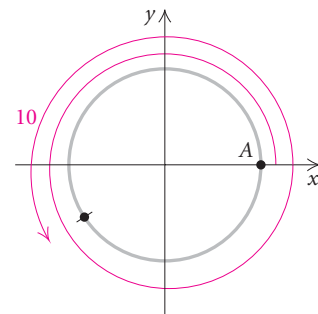
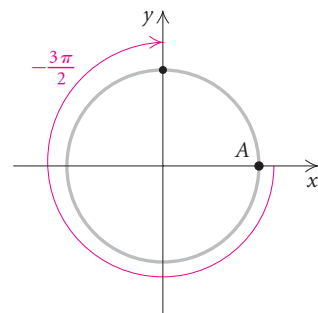
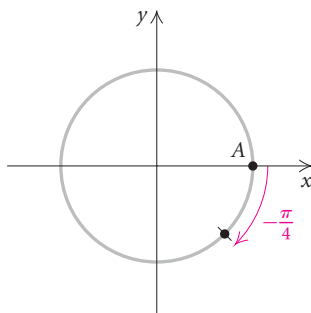

Figure 6

For a negative number, we move clockwise around the circle. Points for $-\pi/4$ and $-3\pi/2$ are shown in the figure below. The number 0 determines the point A .



EXAMPLE 2 On the unit circle, mark the point determined by each of the following real numbers.

a) $\frac{9\pi}{4}$

b) $-\frac{7\pi}{6}$

Solution

- a) Think of $9\pi/4$ as $2\pi + \frac{1}{4}\pi$. (See the figure below.) Since $9\pi/4 > 0$, the point moves counterclockwise. The point goes completely around once and then continues $\frac{1}{4}$ of the way from A to B.

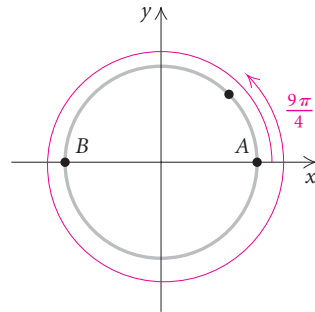

- b) The number $-7\pi/6$ is negative, so the point moves clockwise. From A to B, the distance is π , or $\frac{6}{6}\pi$, so we need to go beyond B another distance of $\pi/6$, clockwise. (See the figure below.)

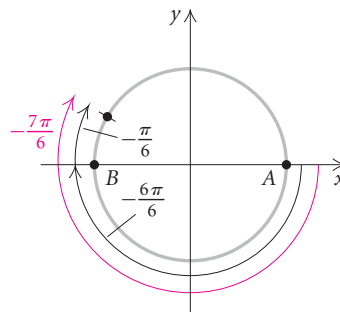

➡ Now Try Exercise 1.

► Radian Measure

Degree measure is a common unit of angle measure in many everyday applications. But in many scientific fields and in mathematics (calculus, in particular), there is another commonly used unit of measure called the *radian*.

Consider the unit circle. Recall that this circle has radius 1. Suppose we measure, moving counterclockwise, an arc of length 1, and mark a point T on the circle.

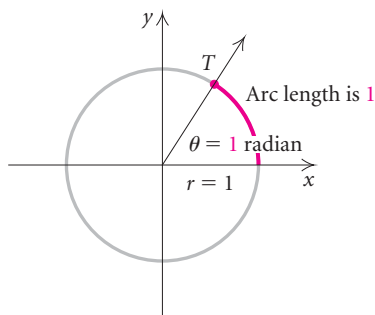

$\longrightarrow 1^\circ$

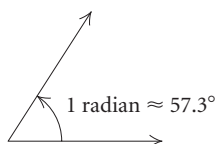

If we draw a ray from the origin through T , we have formed an angle. The measure of that angle is 1 **radian**. The word radian is derived from the word *radius*. Thus measuring 1 “radius” along the circumference of the circle determines an angle whose measure is 1 *radian*. One radian is about 57.3° . Angles that measure 2 radians, 3 radians, and 6 radians are shown below.

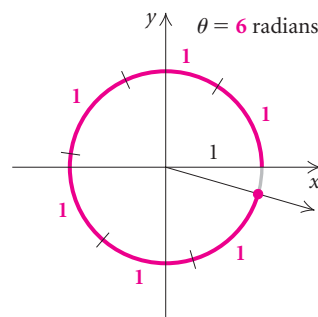
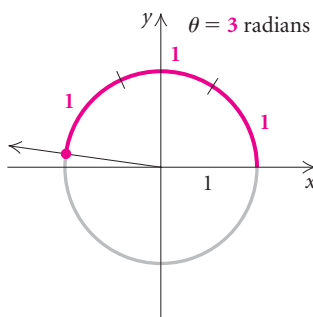
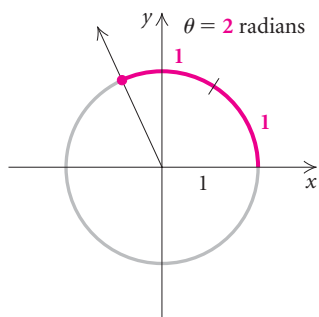

When we make a complete (counterclockwise) revolution, the terminal side coincides with the initial side on the positive x -axis. We then have an angle whose measure is 2π radians, or about 6.28 radians, which is the circumference of the circle:

$$2\pi r = 2\pi(1) = 2\pi.$$

Thus a rotation of 360° (1 revolution) has a measure of 2π radians. A half revolution is a rotation of 180° , or π radians. A quarter revolution is a rotation of 90° , or $\pi/2$ radians, and so on.

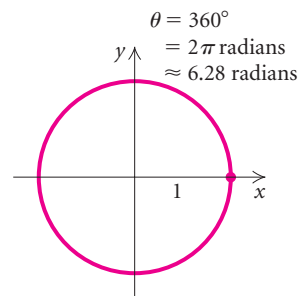
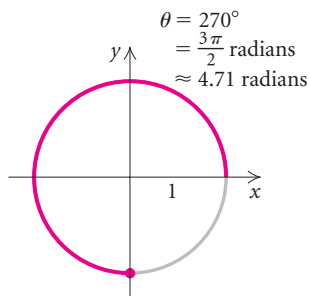
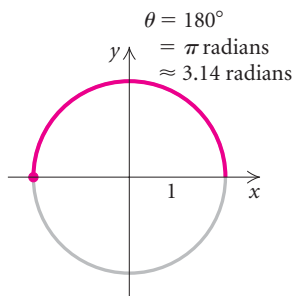
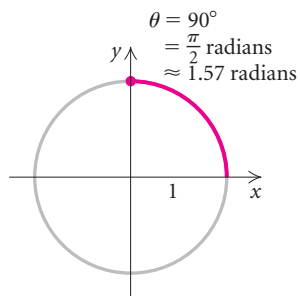

To convert between degrees and radians, we first note that

$$360^\circ = 2\pi \text{ radians.}$$

It follows that

$$180^\circ = \pi \text{ radians.}$$

To make conversions, we multiply by 1, noting the following.

Converting Between Degree Measure and Radian Measure

$$\frac{\pi \text{ radians}}{180^\circ} = \frac{180^\circ}{\pi \text{ radians}} = 1.$$

To convert from degree to radian measure, multiply by $\frac{\pi \text{ radians}}{180^\circ}$.

To convert from radian to degree measure, multiply by $\frac{180^\circ}{\pi \text{ radians}}$.

EXAMPLE 3 Convert each of the following to radians.

a) 120°

b) -297.25°

Solution

a) $120^\circ = 120^\circ \cdot \frac{\pi \text{ radians}}{180^\circ}$ **Multiplying by 1**

$$= \frac{120^\circ}{180^\circ} \pi \text{ radians}$$

$$= \frac{2\pi}{3} \text{ radians, or about 2.09 radians}$$

b) $-297.25^\circ = -297.25^\circ \cdot \frac{\pi \text{ radians}}{180^\circ}$

$$= -\frac{297.25^\circ}{180^\circ} \pi \text{ radians}$$

$$= -\frac{297.25\pi}{180} \text{ radians}$$

$$\approx -5.19 \text{ radians}$$

 **Now Try Exercises 23 and 35.**

EXAMPLE 4 Convert each of the following to degrees.

a) $\frac{3\pi}{4}$ radians

b) 8.5 radians

Solution

$$\begin{aligned} \text{a) } \frac{3\pi}{4} \text{ radians} &= \frac{3\pi}{4} \text{ radians} \cdot \frac{180^\circ}{\pi \text{ radians}} && \text{Multiplying by 1} \\ &= \frac{3\pi}{4\pi} \cdot 180^\circ = \frac{3}{4} \cdot 180^\circ = 135^\circ \end{aligned}$$

$$\begin{aligned} \text{b) } 8.5 \text{ radians} &= 8.5 \text{ radians} \cdot \frac{180^\circ}{\pi \text{ radians}} \\ &= \frac{8.5(180^\circ)}{\pi} \\ &\approx 487.01^\circ \end{aligned}$$

TECHNOLOGY CONNECTION

To convert degrees to radians, we set the calculator in RADIAN mode. Then we enter the angle measure followed by $^\circ$ (degrees) from the ANGLE menu. Example 3 is shown here.

120°	2.094395102
-297.25°	-5.187991202

To convert radians to degrees, we set the calculator in DEGREE mode. Then we enter the angle measure followed by r (radians) from the ANGLE menu. Example 4 is shown here.

$(3\pi/4)^r$	135
8.5 r	487.0141259

➔ Now Try Exercises 47 and 55.

The radian–degree equivalents of the most commonly used angle measures are illustrated in the following figures.

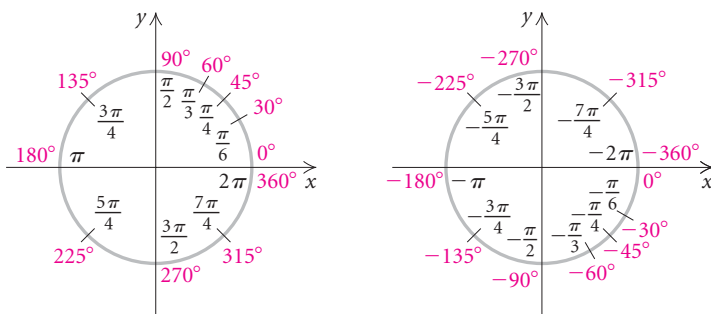

When a rotation is given in radians, the word “radians” is optional and is most often omitted. **Thus if no unit is given for a rotation, the rotation is understood to be in radians.**

We can also find coterminal, complementary, and supplementary angles in radian measure just as we did for degree measure in Section 6.3.

EXAMPLE 5 Find a positive angle and a negative angle that are coterminal with $2\pi/3$. Many answers are possible.

Solution To find angles coterminal with a given angle, we add or subtract multiples of 2π :

$$\frac{2\pi}{3} + 2\pi = \frac{2\pi}{3} + \frac{6\pi}{3} = \frac{8\pi}{3},$$

$$\frac{2\pi}{3} - 3(2\pi) = \frac{2\pi}{3} - \frac{18\pi}{3} = -\frac{16\pi}{3}.$$

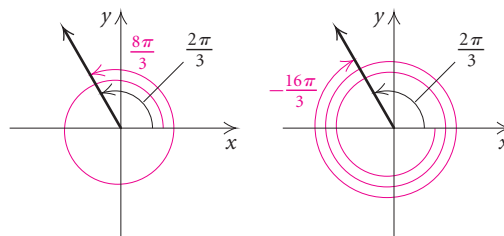

Thus, $8\pi/3$ and $-16\pi/3$ are two of the many angles coterminal with $2\pi/3$.

Now Try Exercise 11.

EXAMPLE 6 Find the complement and the supplement of $\pi/6$.

Solution Since 90° equals $\pi/2$ radians, the complement of $\pi/6$ is

$$\frac{\pi}{2} - \frac{\pi}{6} = \frac{3\pi}{6} - \frac{\pi}{6} = \frac{2\pi}{6}, \quad \text{or} \quad \frac{\pi}{3}.$$

Since 180° equals π radians, the supplement of $\pi/6$ is

$$\pi - \frac{\pi}{6} = \frac{6\pi}{6} - \frac{\pi}{6} = \frac{5\pi}{6}.$$

Thus the complement of $\pi/6$ is $\pi/3$ and the supplement is $5\pi/6$.

Now Try Exercise 15.

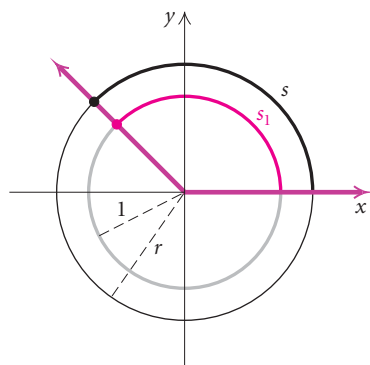

► Arc Length and Central Angles

Radian measure can be determined using a circle other than a unit circle. In the figure at left, a unit circle (with radius 1) is shown along with another circle (with radius r , $r \neq 1$). The angle shown is a **central angle** of both circles.

From geometry, we know that the arcs that the angle subtends have their lengths in the same ratio as the radii of the circles. The radii of the circles are r and 1. The corresponding arc lengths are s and s_1 . Thus we have the proportion

$$\frac{s}{s_1} = \frac{r}{1},$$

which also can be written as

$$\frac{s_1}{1} = \frac{s}{r}.$$

Now s_1 is the *radian measure* of the rotation in question. It is common to use a Greek letter, such as θ , for the measure of an angle or a rotation and the letter s for arc length. Adopting this convention, we rewrite the proportion above as

$$\theta = \frac{s}{r}.$$

In any circle, the measure (in radians) of a central angle, the arc length the angle subtends, and the length of the radius are related in this fashion. Or, in general, the following is true.

Radian Measure

The **radian measure** θ of a rotation is the ratio of the distance s traveled by a point at a radius r from the center of rotation, to the length of the radius r :

$$\theta = \frac{s}{r}.$$

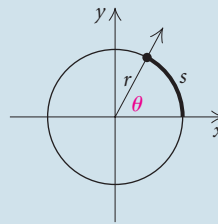

When we are using the formula $\theta = s/r$, θ must be in radians and s and r must be expressed in the same unit.

EXAMPLE 7 Find the measure of a rotation in radians when a point 2 m from the center of rotation travels 4 m.

Solution We have

$$\begin{aligned}\theta &= \frac{s}{r} \\ &= \frac{4 \text{ m}}{2 \text{ m}} = 2. \quad \text{The unit is understood to be radians.}\end{aligned}$$

➔ Now Try Exercise 65.

EXAMPLE 8 Find the length of an arc of a circle of radius 5 cm associated with an angle of $2\pi/3$ radians.

Solution We have

$$\theta = \frac{s}{r}, \quad \text{or} \quad s = r\theta.$$

Thus, $s = 5 \text{ cm} \cdot 2\pi/3$, or about 10.47 cm.

➔ Now Try Exercise 63.

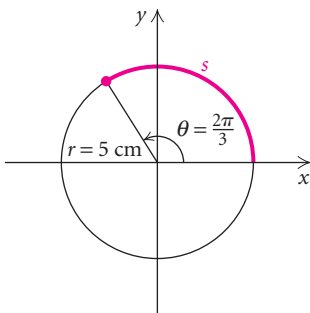

► Linear Speed and Angular Speed

Linear speed is defined to be distance traveled per unit of time. If we use v for linear speed, s for distance, and t for time, then

$$v = \frac{s}{t}.$$

Similarly, **angular speed** is defined to be amount of rotation per unit of time. For example, we might speak of the angular speed of a bicycle wheel as 150 revolutions per minute or the angular speed of the earth as 2π radians per day. The Greek letter ω (omega) is generally used for angular speed. Thus for a rotation θ and time t , angular speed is defined as

$$\omega = \frac{\theta}{t}.$$

As an example of how these definitions can be applied, let's consider the refurbished carousel at the Children's Museum in Indianapolis, Indiana. It consists of three circular rows of animals. All animals, regardless of the row, travel at the same angular speed. But the animals in the outer row travel at a greater linear speed than those in the inner rows. What is the relationship between the linear speed v and the angular speed ω ?

To develop the relationship we seek, recall that, for rotations measured in radians, $\theta = s/r$. This is equivalent to

$$s = r\theta.$$

We divide by time, t , to obtain

$$\frac{s}{t} = \frac{r\theta}{t} \quad \text{Dividing by } t$$

$$\frac{s}{t} = r \cdot \frac{\theta}{t}$$

\downarrow \downarrow
 v ω

Now s/t is linear speed v and θ/t is angular speed ω . Thus we have the relationship we seek,

$$v = r\omega.$$



Copyright © 2006 The Children's Museum of Indianapolis



Linear Speed in Terms of Angular Speed

The **linear speed** v of a point a distance r from the center of rotation is given by

$$v = r\omega,$$

where ω is the **angular speed**, in radians per unit of time.

For the formula $v = r\omega$, the units of distance for v and r must be the same, ω must be in radians per unit of time, and the units of time for v and ω must be the same.

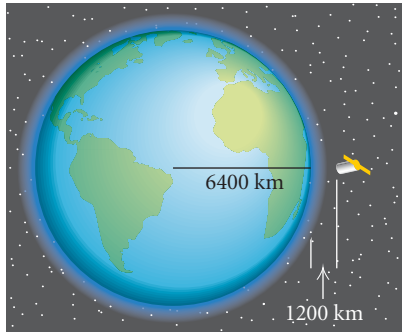

EXAMPLE 9 *Linear Speed of an Earth Satellite.* An earth satellite in circular orbit 1200 km high makes one complete revolution every 90 min. What is its linear speed? Use 6400 km for the length of a radius of the earth.

Solution To use the formula $v = r\omega$, we need to know r and ω :

$$r = 6400 \text{ km} + 1200 \text{ km} \quad \text{Radius of earth plus height of satellite}$$

$$= 7600 \text{ km};$$

$$\omega = \frac{\theta}{t} = \frac{2\pi}{90 \text{ min}} = \frac{\pi}{45 \text{ min}}. \quad \text{We have, as usual, omitted the word radians.}$$

Now, using $v = r\omega$, we have

$$v = 7600 \text{ km} \cdot \frac{\pi}{45 \text{ min}} = \frac{7600\pi}{45} \cdot \frac{\text{km}}{\text{min}} \approx 531 \frac{\text{km}}{\text{min}}.$$

Thus the linear speed of the satellite is approximately 531 km/min.

➔ Now Try Exercise 71.

EXAMPLE 10 *Angular Speed of a Capstan.* An anchor is hoisted at a rate of 2 ft/sec as the chain is wound around a capstan with a 1.8-yd diameter. What is the angular speed of the capstan?



Solution We will use the formula $v = r\omega$ in the form $\omega = v/r$, taking care to use the proper units. Since v is given in feet per second, we need to give r in feet:

$$r = \frac{d}{2} = \frac{1.8}{2} \text{ yd} \cdot \frac{3 \text{ ft}}{1 \text{ yd}} = 2.7 \text{ ft}.$$

Then ω will be in radians per second:

$$\omega = \frac{v}{r} = \frac{2 \text{ ft/sec}}{2.7 \text{ ft}} = \frac{2 \text{ ft}}{\text{sec}} \cdot \frac{1}{2.7 \text{ ft}} \approx 0.741/\text{sec}.$$

Thus the angular speed is approximately 0.741 radian/sec.

➔ Now Try Exercise 77.

The formulas $\theta = \omega t$ and $v = r\omega$ can be used in combination to find distances and angles in various situations involving rotational motion.

EXAMPLE 11 *Angle of Revolution.* A 2010 Dodge Ram Crew Cab 4 × 4 is traveling at a speed of 70 mph. Its tires have an outside diameter of 29.86 in. Find the angle through which a tire turns in 10 sec.



Solution Recall that $\omega = \theta/t$, or $\theta = \omega t$. Thus we can find θ if we know ω and t . To find ω , we use the formula $v = r\omega$. The linear speed v of a point on the outside of the tire is the speed of the Dodge Ram, 70 mph. For convenience, we first convert 70 mph to feet per second:

$$\begin{aligned} v &= 70 \frac{\text{mi}}{\text{hr}} \cdot \frac{1 \text{ hr}}{60 \text{ min}} \cdot \frac{1 \text{ min}}{60 \text{ sec}} \cdot \frac{5280 \text{ ft}}{1 \text{ mi}} \\ &\approx 102.667 \frac{\text{ft}}{\text{sec}}. \end{aligned}$$

The radius of the tire is half the diameter. Now $r = d/2 = 29.86/2 = 14.93$ in. We will convert to feet, since v is in feet per second:

$$\begin{aligned} r &= 14.93 \text{ in.} \cdot \frac{1 \text{ ft}}{12 \text{ in.}} \\ &= \frac{14.93}{12} \text{ ft} \\ &\approx 1.24 \text{ ft}. \end{aligned}$$

Using $v = r\omega$, we have

$$102.667 \frac{\text{ft}}{\text{sec}} = 1.24 \text{ ft} \cdot \omega,$$

so

$$\omega = \frac{102.667 \text{ ft/sec}}{1.24 \text{ ft}} \approx \frac{82.80}{\text{sec}}.$$

Then in 10 sec,

$$\theta = \omega t = \frac{82.80}{\text{sec}} \cdot 10 \text{ sec} \approx 828.$$

Thus the angle, in radians, through which a tire turns in 10 sec is 828.

STUDY TIP

The *Student's Solutions Manual* is an excellent resource if you need additional help with an exercise in the exercise sets. It contains worked-out solutions to the odd-numbered exercises in the exercise sets.

6.4 Exercise Set

For each of Exercises 1–4, sketch a unit circle and mark the points determined by the given real numbers.

- | | | |
|------------------------|-----------------------|----------------------|
| 1. a) $\frac{\pi}{4}$ | b) $\frac{3\pi}{2}$ | c) $\frac{3\pi}{4}$ |
| d) π | e) $\frac{11\pi}{4}$ | f) $\frac{17\pi}{4}$ |
| 2. a) $\frac{\pi}{2}$ | b) $\frac{5\pi}{4}$ | c) 2π |
| d) $\frac{9\pi}{4}$ | e) $\frac{13\pi}{4}$ | f) $\frac{23\pi}{4}$ |
| 3. a) $\frac{\pi}{6}$ | b) $\frac{2\pi}{3}$ | c) $\frac{7\pi}{6}$ |
| d) $\frac{10\pi}{6}$ | e) $\frac{14\pi}{6}$ | f) $\frac{23\pi}{4}$ |
| 4. a) $-\frac{\pi}{2}$ | b) $-\frac{3\pi}{4}$ | c) $-\frac{5\pi}{6}$ |
| d) $-\frac{5\pi}{2}$ | e) $-\frac{17\pi}{6}$ | f) $-\frac{9\pi}{4}$ |

Find two real numbers between -2π and 2π that determine each of the points on the unit circle.

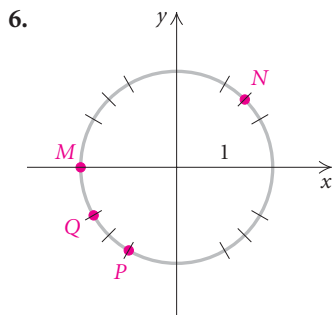
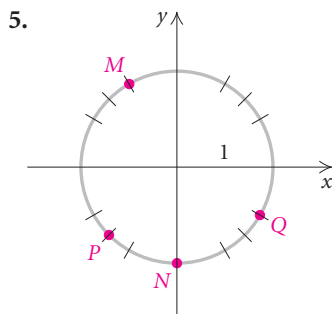

For Exercises 7 and 8, sketch a unit circle and mark the approximate location of the point determined by the given real number.

- | | |
|------------|--------|
| 7. a) 2.4 | b) 7.5 |
| c) 32 | d) 320 |
| 8. a) 0.25 | b) 1.8 |
| c) 47 | d) 500 |

Find a positive angle and a negative angle that are coterminal with the given angle. Answers may vary.

- | | |
|-----------------------|-----------------------|
| 9. $\frac{\pi}{4}$ | 10. $\frac{5\pi}{3}$ |
| 11. $\frac{7\pi}{6}$ | 12. π |
| 13. $-\frac{2\pi}{3}$ | 14. $-\frac{3\pi}{4}$ |

Find the complement and the supplement.

- | | | |
|---------------------|-----------------------|----------------------|
| 15. $\frac{\pi}{3}$ | 16. $\frac{5\pi}{12}$ | 17. $\frac{3\pi}{8}$ |
| 18. $\frac{\pi}{4}$ | 19. $\frac{\pi}{12}$ | 20. $\frac{\pi}{6}$ |

Convert to radian measure. Leave the answer in terms of π .

- | | |
|--------------------|-------------------|
| 21. 75° | 22. 30° |
| 23. 200° | 24. -135° |
| 25. -214.6° | 26. 37.71° |
| 27. -180° | 28. 90° |
| 29. 12.5° | 30. 6.3° |
| 31. -340° | 32. -60° |

Convert to radian measure. Round the answer to two decimal places.

- | | |
|-------------------|--------------------|
| 33. 240° | 34. 15° |
| 35. -60° | 36. 145° |
| 37. 117.8° | 38. -231.2° |
| 39. 1.354° | 40. 584° |

41. 345° 42. -75°
 43. 95° 44. 24.8°

Convert to degree measure. Round the answer to two decimal places.

45. $-\frac{3\pi}{4}$ 46. $\frac{7\pi}{6}$
 47. 8π 48. $-\frac{\pi}{3}$
 49. 1 50. -17.6
 51. 2.347 52. 25
 53. $\frac{5\pi}{4}$ 54. -6π
 55. -90 56. 37.12
 57. $\frac{2\pi}{7}$ 58. $\frac{\pi}{9}$

59. Certain positive angles are marked here in degrees. Find the corresponding radian measures.

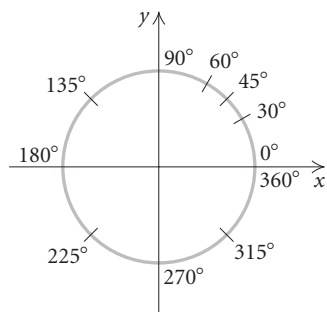

60. Certain negative angles are marked here in degrees. Find the corresponding radian measures.

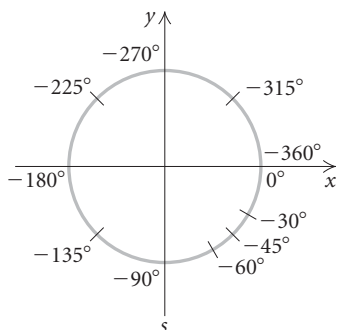

Arc Length and Central Angles. Complete the table below. Round the answers to two decimal places.

	Distance, s (arc length)	Radius, r	Angle, θ
61.	8 ft	$3\frac{1}{2}$ ft	_____
62.	200 cm	_____	45°
63.	_____	4.2 in.	$\frac{5\pi}{12}$
64.	16 yd	_____	5
65.	In a circle with a 120-cm radius, an arc 132 cm long subtends an angle of how many radians? how many degrees, to the nearest degree?		
66.	In a circle with a 10-ft diameter, an arc 20 ft long subtends an angle of how many radians? how many degrees, to the nearest degree?		
67.	In a circle with a 2-yd radius, how long is an arc associated with an angle of 1.6 radians?		
68.	In a circle with a 5-m radius, how long is an arc associated with an angle of 2.1 radians?		
69.	Angle of Revolution. A tire on a 2011 Ford Fiesta has an outside diameter of 27.66 in. Through what angle (in radians) does the tire turn while traveling 1 mi?		



70. **Angle of Revolution.** Through how many radians does the minute hand of a wristwatch rotate from 12:40 P.M. to 1:30 P.M.?



71. **Linear Speed.** A flywheel with a 15-cm diameter is rotating at a rate of 7 radians/sec. What is the linear speed of a point on its rim, in centimeters per minute?
72. **Linear Speed.** A wheel with a 30-cm radius is rotating at a rate of 3 radians/sec. What is the linear speed of a point on its rim, in meters per minute?
73. **Linear Speeds on a Carousel.** When Brett and Will ride the carousel described earlier in this section, Brett always selects a horse on the outside row, whereas Will prefers the row closest to the center. These rows are 19 ft 3 in. and 13 ft 11 in. from the center, respectively. The angular speed of the carousel is 2.4 revolutions per minute (Source: The Children's Museum, Indianapolis, IN). What is the difference, in miles per hour, in the linear speeds of Brett and Will?
74. **Angular Speed of a Printing Press.** This text was printed on a four-color web heatset offset press. A cylinder on this press has a 21-in. diameter. The linear speed of a point on the cylinder's surface is 18.33 ft/sec. (Source: R. R. Donnelley, Willard, Ohio) What is the angular speed of the cylinder, in revolutions per hour? Printers often refer to the angular speed as impressions per hour (IPH).



75. **Linear Speed at the Equator.** The earth has a 4000-mi radius and rotates one revolution every

24 hr. What is the linear speed of a point on the equator, in miles per hour?

76. **Linear Speed of the Earth.** The earth is about 93,000,000 mi from the sun and traverses its orbit, which is nearly circular, every 365.25 days. What is the linear velocity of the earth in its orbit, in miles per hour?
77. **The Tour de France.** Alberto Contador of Spain won the 2010 Tour de France bicycle race. The wheel of his bicycle had a 67-cm diameter. His overall average linear speed during the race was 39.596 km/h (Source: Preston Green, Bicycle Garage Indy, Greenwood, Indiana). What was the angular speed of the wheel, in revolutions per hour?
78. **Determining the Speed of a River.** A waterwheel has a 10-ft radius. To get a good approximation of the speed of the river, you count the revolutions of the wheel and find that it makes 14 revolutions per minute (rpm). What is the speed of the river, in miles per hour?



79. **John Deere Tractor.** A rear wheel on a John Deere 8300 farm tractor has a 23-in. radius. Find the angle (in radians) through which a wheel rotates in 12 sec if the tractor is traveling at a speed of 22 mph.



Skill Maintenance

In each of Exercises 80–87, fill in the blanks with the correct terms. Some of the given choices will not be used.

inverse	relation
horizontal line	vertical asymptote
vertical line	horizontal asymptote
exponential function	even function
logarithmic function	odd function
natural	sine of θ
common	cosine of θ
logarithm	tangent of θ
one-to-one	

80. The domain of a(n) _____ function f is the range of the inverse f^{-1} .
81. The _____ is the length of the side adjacent to θ divided by the length of the hypotenuse.
82. The function $f(x) = a^x$, where x is a real number, $a > 0$ and $a \neq 1$, is called the _____, base a .
83. The graph of a rational function may or may not cross a(n) _____.
84. If the graph of a function f is symmetric with respect to the origin, we say that it is a(n) _____.
85. Logarithms, base e , are called _____ logarithms.
86. If it is possible for a(n) _____ to intersect the graph of a function more than once, then the function is not one-to-one and its _____ is not a function.
87. A(n) _____ is an exponent.

Synthesis

88. A point on the unit circle has y -coordinate $-\sqrt{21}/5$. What is its x -coordinate? Check using a calculator.
89. On the earth, one degree of latitude is how many kilometers? how many miles? (Assume that the radius of the earth is 6400 km, or 4000 mi, approximately.)
90. A **grad** is a unit of angle measure similar to a degree. A right angle has a measure of 100 grads. Convert each of the following to grads.

- a) 48° b) $\frac{5\pi}{7}$

91. A **mil** is a unit of angle measure. A right angle has a measure of 1600 mils. Convert each of the following to degrees, minutes, and seconds.

- a) 100 mils b) 350 mils

92. **Angular Speed of a Pulley.** Two pulleys, 50 cm and 30 cm in diameter, respectively, are connected by a belt. The larger pulley makes 12 revolutions per minute. Find the angular speed of the smaller pulley, in radians per second.

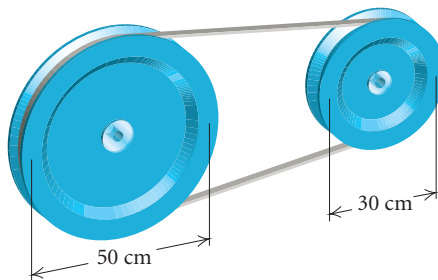

93. **Angular Speed of a Gear Wheel.** One gear wheel turns another, the teeth being on the rims. The wheels have 40-cm and 50-cm radii, and the smaller wheel rotates at 20 rpm. Find the angular speed of the larger wheel, in radians per second.

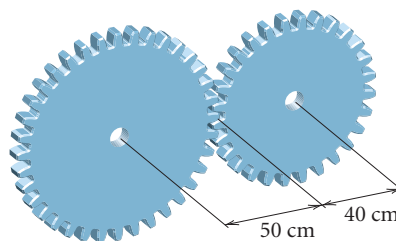

94. **Hands of a Clock.** At what time between noon and 1:00 P.M. are the hands of a clock perpendicular?
95. **Distance Between Points on the Earth.** To find the distance between two points on the earth when their latitude and longitude are known, we can use a right triangle for an excellent approximation if the points are not too far apart. Point A is at latitude $38^\circ 27' 30''$ N, longitude $82^\circ 57' 15''$ W; and point B is at latitude $38^\circ 28' 45''$ N, longitude $82^\circ 56' 30''$ W. Find the distance from A to B in nautical miles. (One minute of latitude is one nautical mile.)

Circular Functions: Graphs and Properties

6.5

- ▶ Given the coordinates of a point on the unit circle, find its reflections across the x -axis, the y -axis, and the origin.
- ▶ Determine the six trigonometric function values for a real number when the coordinates of the point on the unit circle determined by that real number are given.
- ▶ Find trigonometric function values for any real number using a calculator.
- ▶ Graph the six circular functions and state their properties.

The domains of the trigonometric functions, defined in Sections 6.1 and 6.3, have been sets of angles or rotations measured in a real number of degree units. We can also consider the domains to be sets of real numbers, or radians, introduced in Section 6.4. Many applications in calculus that use the trigonometric functions refer only to radians.

Let's again consider radian measure and the unit circle. We defined radian measure for θ as

$$\theta = \frac{s}{r}.$$

When $r = 1$,

$$\theta = \frac{s}{1}, \quad \text{or} \quad \theta = s.$$

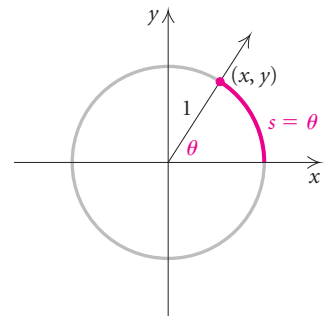

STUDY TIP

Take advantage of the numerous detailed art pieces in this text. They provide a visual image of the concept being discussed. Taking the time to study each figure is an efficient way to learn and retain the concepts.

The arc length s on the unit circle is the same as the radian measure of the angle θ .

In the figure above, the point (x, y) is the point where the terminal side of the angle with radian measure s intersects the unit circle. We can now extend our definitions of the trigonometric functions using domains composed of real numbers, or radians.

In the definitions, s can be considered the radian measure of an angle or the measure of an arc length on the unit circle. Either way, s is a real number. To each real number s , there corresponds an arc length s on the unit circle. Trigonometric functions with domains composed of real numbers are called **circular functions**.

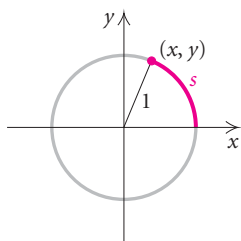

Basic Circular Functions

For a real number s that determines a point (x, y) on the unit circle:

$$\sin s = \text{second coordinate} = y,$$

$$\cos s = \text{first coordinate} = x,$$

$$\tan s = \frac{\text{second coordinate}}{\text{first coordinate}} = \frac{y}{x} \quad (x \neq 0),$$

$$\csc s = \frac{1}{\text{second coordinate}} = \frac{1}{y} \quad (y \neq 0),$$

$$\sec s = \frac{1}{\text{first coordinate}} = \frac{1}{x} \quad (x \neq 0),$$

$$\cot s = \frac{\text{first coordinate}}{\text{second coordinate}} = \frac{x}{y} \quad (y \neq 0).$$

We can consider the domains of trigonometric functions to be real numbers rather than angles. We can determine these values for a specific real number if we know the coordinates of the point on the unit circle determined by that number. As with degree measure, we can also find these function values directly using a calculator.

► Reflections on the Unit Circle

Let's consider the unit circle and a few of its points. For any point (x, y) on the unit circle, $x^2 + y^2 = 1$, we know that $-1 \leq x \leq 1$ and $-1 \leq y \leq 1$. If we know the x - or y -coordinate of a point on the unit circle, we can find the other coordinate. If $x = \frac{3}{5}$, then

$$\begin{aligned} \left(\frac{3}{5}\right)^2 + y^2 &= 1 \\ y^2 &= 1 - \frac{9}{25} = \frac{16}{25} \\ y &= \pm \frac{4}{5}. \end{aligned}$$

Thus, $(\frac{3}{5}, \frac{4}{5})$ and $(\frac{3}{5}, -\frac{4}{5})$ are points on the unit circle. There are two points with an x -coordinate of $\frac{3}{5}$.

Now let's consider the radian measure $\pi/3$ and determine the coordinates of the point on the unit circle determined by $\pi/3$. We construct a right triangle by dropping a perpendicular segment from the point to the x -axis.

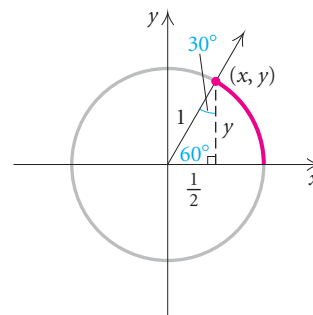
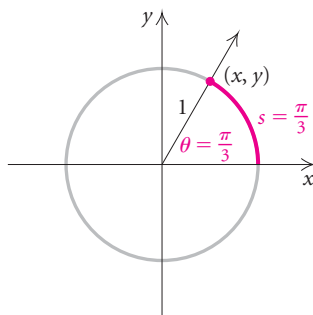
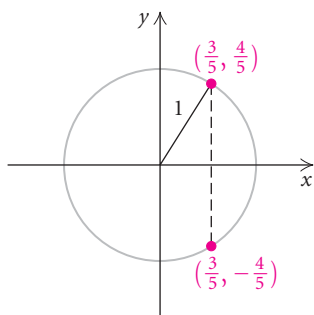

Since $\pi/3 = 60^\circ$, we have a 30° – 60° right triangle in which the side opposite the 30° angle is one half of the hypotenuse. The hypotenuse, or radius, is 1, so the side opposite the 30° angle is $\frac{1}{2} \cdot 1$, or $\frac{1}{2}$. Using the Pythagorean equation, we can find the other side:

$$\begin{aligned}\left(\frac{1}{2}\right)^2 + y^2 &= 1 \\ y^2 &= 1 - \frac{1}{4} = \frac{3}{4} \\ y &= \sqrt{\frac{3}{4}} = \frac{\sqrt{3}}{2}.\end{aligned}$$

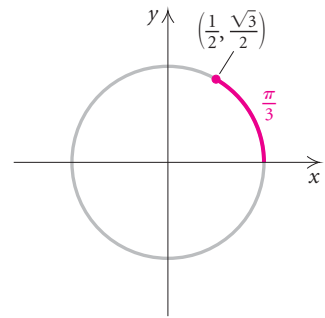

We know that y is positive since the point is in the first quadrant. Thus the coordinates of the point determined by $\pi/3$ are $x = 1/2$ and $y = \sqrt{3}/2$, or $(1/2, \sqrt{3}/2)$. We can always check to see if a point is on the unit circle by substituting into the equation $x^2 + y^2 = 1$:

$$\left(\frac{1}{2}\right)^2 + \left(\frac{\sqrt{3}}{2}\right)^2 = \frac{1}{4} + \frac{3}{4} = 1.$$

Because a unit circle is symmetric with respect to the x -axis, the y -axis, and the origin, we can use the coordinates of one point on the unit circle to find coordinates of its reflections.

EXAMPLE 1 Each of the following points lies on the unit circle. Find their reflections across the x -axis, the y -axis, and the origin.

a) $\left(\frac{3}{5}, \frac{4}{5}\right)$ b) $\left(\frac{\sqrt{2}}{2}, \frac{\sqrt{2}}{2}\right)$ c) $\left(\frac{1}{2}, \frac{\sqrt{3}}{2}\right)$

Solution

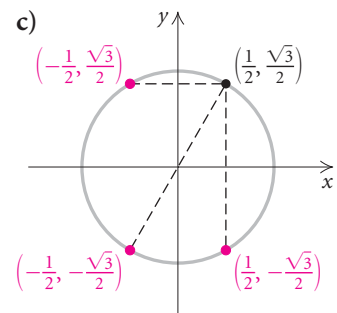
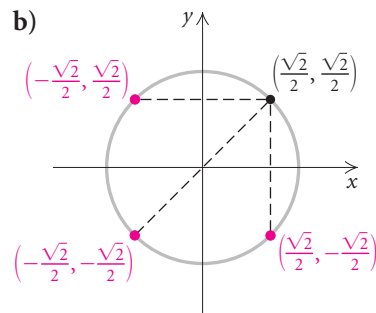
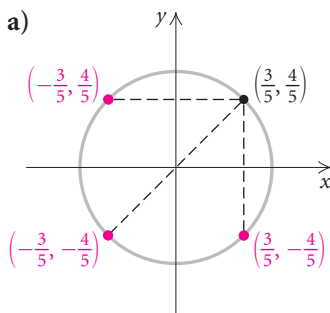

Now Try Exercise 1.

► Finding Function Values

Knowing the coordinates of only a few points on the unit circle along with their reflections allows us to find trigonometric function values of the most frequently used real numbers, or radians.

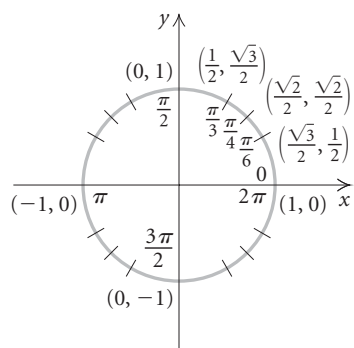

EXAMPLE 2 Find each of the following function values.

- | | |
|---------------------------------------|--|
| a) $\tan \frac{\pi}{3}$ | b) $\cos \frac{3\pi}{4}$ |
| c) $\sin \left(-\frac{\pi}{6}\right)$ | d) $\cos \frac{4\pi}{3}$ |
| e) $\cot \pi$ | f) $\csc \left(-\frac{7\pi}{2}\right)$ |

Solution We locate the point on the unit circle determined by the rotation, and then find its coordinates using reflection if necessary.

- a) The coordinates of the point determined by $\pi/3$ are $(1/2, \sqrt{3}/2)$.

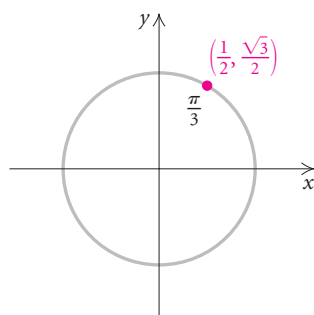

$$\text{Thus, } \tan \frac{\pi}{3} = \frac{y}{x} = \frac{\sqrt{3}/2}{1/2} = \sqrt{3}.$$

- c) The reflection of $(\sqrt{3}/2, 1/2)$ across the x -axis is $(\sqrt{3}/2, -1/2)$.

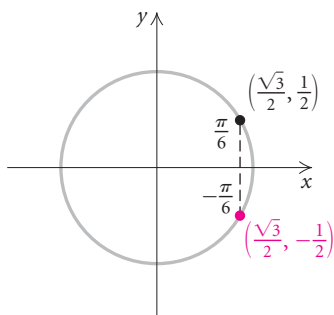

$$\text{Thus, } \sin \left(-\frac{\pi}{6}\right) = y = -\frac{1}{2}.$$

- b) The reflection of $(\sqrt{2}/2, \sqrt{2}/2)$ across the y -axis is $(-\sqrt{2}/2, \sqrt{2}/2)$.

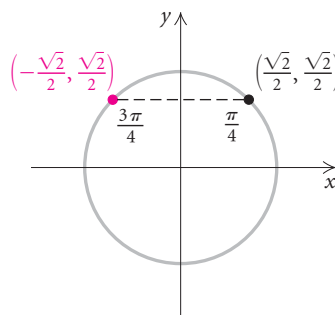

$$\text{Thus, } \cos \frac{3\pi}{4} = x = -\frac{\sqrt{2}}{2}.$$

- d) The reflection of $(1/2, \sqrt{3}/2)$ across the origin is $(-1/2, -\sqrt{3}/2)$.

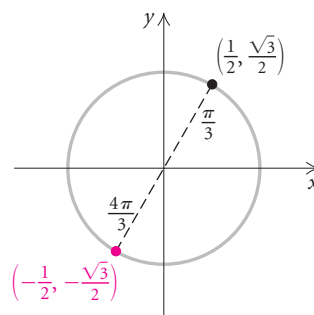

$$\text{Thus, } \cos \frac{4\pi}{3} = x = -\frac{1}{2}.$$

e) The coordinates of the point determined by π are $(-1, 0)$.

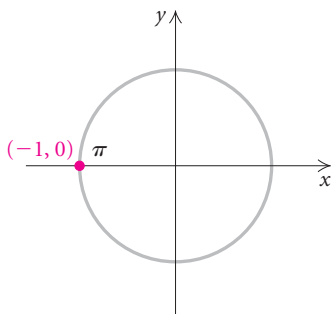

Thus, $\cot \pi = \frac{x}{y} = \frac{-1}{0}$, which is not defined.

We can also think of $\cot \pi$ as the reciprocal of $\tan \pi$. Since $\tan \pi = y/x = 0/-1 = 0$ and the reciprocal of 0 is not defined, we know that $\cot \pi$ is not defined.

f) The coordinates of the point determined by $-7\pi/2$ are $(0, 1)$.

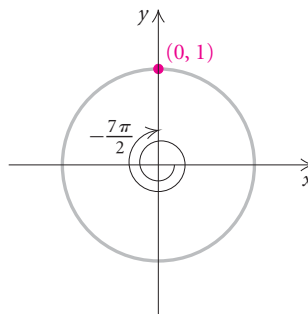

Thus, $\csc \left(-\frac{7\pi}{2} \right) = \frac{1}{y} = \frac{1}{1} = 1$.

➔ Now Try Exercises 9 and 11.

TECHNOLOGY CONNECTION

To find trigonometric function values of angles measured in radians, we set the calculator in RADIAN mode.

NORMAL	SCI	ENG	
FLOAT	0123456789		
RADIAN	DEGREE		
FUNC	PAR	POL	SEQ
CONNECTED	DOT		
SEQUENTIAL	SIMUL		
REAL	a+bi	re-θi	
FULL	HORIZ	G-T	

Parts (a)–(c) of Example 3 are shown in the window below.

$\cos(2\pi/5)$.3090169944
$\tan(-3)$.1425465431
$\sin(24.9)$	-.2306457059

Using a calculator, we can find trigonometric function values of any real number without knowing the coordinates of the point that it determines on the unit circle. Most calculators have both degree mode and radian mode. When finding function values of radian measures, or real numbers, we *must* set the calculator in RADIAN mode.

EXAMPLE 3 Find each of the following function values of radian measures using a calculator. Round the answer to four decimal places.

a) $\cos \frac{2\pi}{5}$

b) $\tan(-3)$

c) $\sin 24.9$

d) $\sec \frac{\pi}{7}$

Solution Using a calculator set in RADIAN mode, we find the values.

a) $\cos \frac{2\pi}{5} \approx 0.3090$

b) $\tan(-3) \approx 0.1425$

c) $\sin 24.9 \approx -0.2306$

d) $\sec \frac{\pi}{7} = \frac{1}{\cos \frac{\pi}{7}} \approx 1.1099$

Note in part (d) that the secant function value can be found by taking the reciprocal of the cosine value. Thus we can enter $\cos \pi/7$ and use the reciprocal key.

➔ Now Try Exercises 25 and 33.

TECHNOLOGY CONNECTION

We can graph the unit circle using a graphing calculator. We use PARAMETRIC mode with the following window and let $X1T = \cos T$ and $Y1T = \sin T$. Here we use DEGREE mode.

WINDOW

$T_{\min} = 0$
 $T_{\max} = 360$
 $T_{\text{step}} = 15$
 $X_{\min} = -1.5$
 $X_{\max} = 1.5$
 $X_{\text{scl}} = 1$
 $Y_{\min} = -1$
 $Y_{\max} = 1$
 $Y_{\text{scl}} = 1$

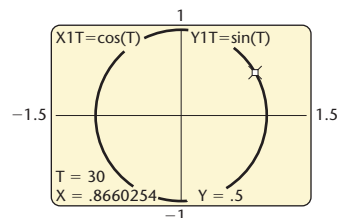

Using the trace key and an arrow key to move the cursor around the unit circle, we see the T , X , and Y values appear on the screen. What do they represent? Repeat this exercise in RADIAN mode. What do the T , X , and Y values represent? (For more on parametric equations, see Section 10.7.)

From the definitions on p. 537, we can relabel any point (x, y) on the unit circle as $(\cos s, \sin s)$, where s is any real number.

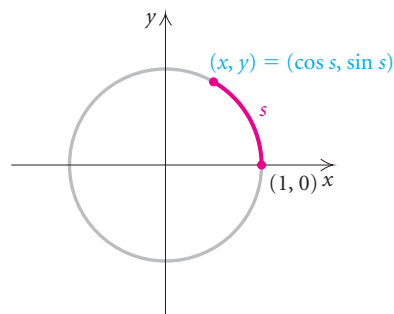

► Graphs of the Sine and Cosine Functions

Properties of functions can be observed from their graphs. We begin by graphing the sine and cosine functions. We make a table of values, plot the points, and then connect those points with a smooth curve. It is helpful to first draw a unit circle and label a few points with coordinates. We can either

use the coordinates as the function values or find approximate sine and cosine values directly with a calculator.

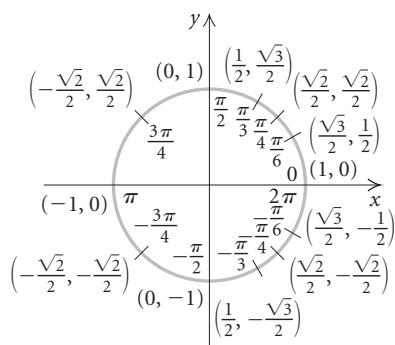

s	$\sin s$	$\cos s$
0	0	1
$\pi/6$	0.5	0.8660
$\pi/4$	0.7071	0.7071
$\pi/3$	0.8660	0.5
$\pi/2$	1	0
$3\pi/4$	0.7071	-0.7071
π	0	-1
$5\pi/4$	-0.7071	-0.7071
$3\pi/2$	-1	0
$7\pi/4$	-0.7071	0.7071
2π	0	1

s	$\sin s$	$\cos s$
0	0	1
$-\pi/6$	-0.5	0.8660
$-\pi/4$	-0.7071	0.7071
$-\pi/3$	-0.8660	0.5
$-\pi/2$	-1	0
$-3\pi/4$	-0.7071	-0.7071
$-\pi$	0	-1
$-5\pi/4$	0.7071	-0.7071
$-3\pi/2$	1	0
$-7\pi/4$	0.7071	0.7071
-2π	0	1

The graphs are as follows.

TECHNOLOGY CONNECTION

The graphing calculator provides an efficient way to graph trigonometric functions. Here we use RADIAN mode to graph $y = \sin x$ and $y = \cos x$.

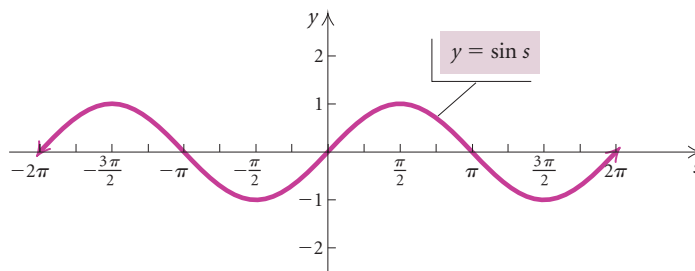
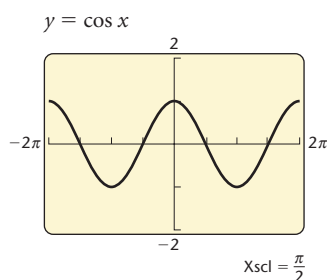
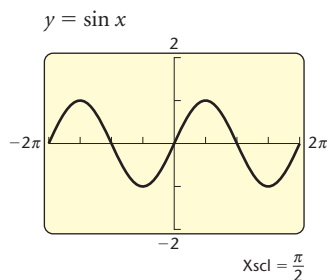

The sine function

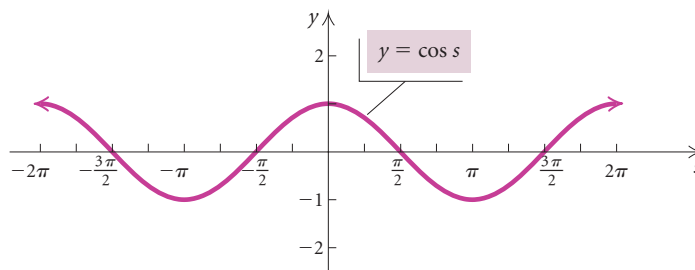

The cosine function

The sine and cosine functions are continuous functions. Note in the graph of the sine function that function values increase from 0 at $s = 0$ to 1 at $s = \pi/2$, then decrease to 0 at $s = \pi$, decrease further to -1 at $s = 3\pi/2$, and increase to 0 at 2π . The reverse pattern follows when s decreases from 0 to -2π . Note in the graph of the cosine function that function values start at 1 when $s = 0$, and decrease to 0 at $s = \pi/2$. They decrease further to -1 at $s = \pi$, then increase to 0 at $s = 3\pi/2$, and

increase further to 1 at $s = 2\pi$. An identical pattern follows when s decreases from 0 to -2π .

From the unit circle and the graphs of the functions, we know that the domain of both the sine and cosine functions is the entire set of real numbers, $(-\infty, \infty)$. The range of each function is the set of all real numbers from -1 to 1 , $[-1, 1]$.

Domain and Range of the Sine Function and the Cosine Function

The *domain* of the sine function and the cosine function is $(-\infty, \infty)$.

The *range* of the sine function and the cosine function is $[-1, 1]$.

TECHNOLOGY CONNECTION

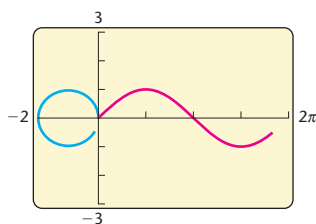
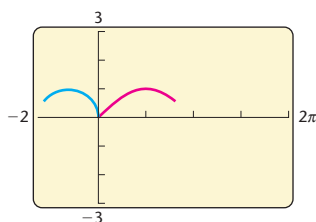

Another way to construct the sine and cosine graphs is by considering the unit circle and transferring vertical distances for the sine function and horizontal distances for the cosine function. Using a graphing calculator, we can visualize the transfer of these distances. We use the calculator set in PARAMETRIC and RADIAN modes and let $X_1T = \cos T - 1$ and $Y_1T = \sin T$ for the unit circle centered at $(-1, 0)$ and $X_2T = T$ and $Y_2T = \sin T$ for the sine curve. Use the following window settings.

$$\begin{array}{lll} T_{\min} = 0 & X_{\min} = -2 & Y_{\min} = -3 \\ T_{\max} = 2\pi & X_{\max} = 2\pi & Y_{\max} = 3 \\ T_{\text{step}} = .1 & X_{\text{scl}} = \pi/2 & Y_{\text{scl}} = 1 \end{array}$$

With the calculator set in SIMULTANEOUS mode, we can actually watch the sine function (in red) “unwind” from the unit circle (in blue). In the two screens at left, we partially illustrate this animated procedure.

Consult your calculator’s instruction manual for specific keystrokes and graph both the sine curve and the cosine curve in this manner. (For more on parametric equations, see Section 10.7.)

A function with a repeating pattern is called **periodic**. The sine function and the cosine function are examples of periodic functions. The values of these functions repeat themselves every 2π units. In other words, for any s , we have

$$\sin(s + 2\pi) = \sin s \quad \text{and} \quad \cos(s + 2\pi) = \cos s.$$

To see this another way, think of the part of the graph between 0 and 2π and note that the rest of the graph consists of copies of it. If we translate the graph of $y = \sin x$ or $y = \cos x$ to the left or right 2π units, we will obtain the original graph. We say that each of these functions has a period of 2π .

Periodic Function

A function f is said to be **periodic** if there exists a positive constant p such that

$$f(s + p) = f(s)$$

for all s in the domain of f . The smallest such positive number p is called the period of the function.

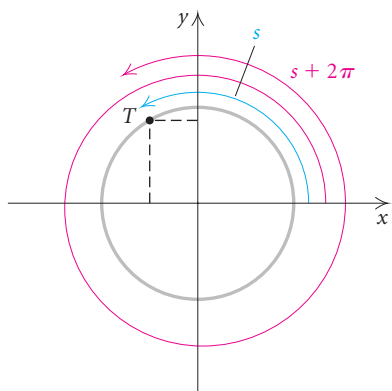

The period p can be thought of as the length of the shortest recurring interval.

We can also use the unit circle to verify that the period of the sine and cosine functions is 2π . Consider any real number s and the point T that it determines on a unit circle, as shown at left. If we increase s by 2π , the point determined by $s + 2\pi$ is again the point T . Hence for any real number s ,

$$\sin(s + 2\pi) = \sin s \quad \text{and} \quad \cos(s + 2\pi) = \cos s.$$

It is also true that $\sin(s + 4\pi) = \sin s$, $\sin(s + 6\pi) = \sin s$, and so on. In fact, for *any* integer k , the following equations are identities:

$$\sin[s + k(2\pi)] = \sin s \quad \text{and} \quad \cos[s + k(2\pi)] = \cos s,$$

or

$$\sin s = \sin(s + 2k\pi) \quad \text{and} \quad \cos s = \cos(s + 2k\pi).$$

The **amplitude** of a periodic function is defined as one half of the distance between its maximum and minimum function values. It is always positive. Both the graphs and the unit circle verify that the maximum value of the sine and cosine functions is 1, whereas the minimum value of each is -1 . Thus,

$$\text{the amplitude of the sine function} = \frac{1}{2}|1 - (-1)| = 1$$

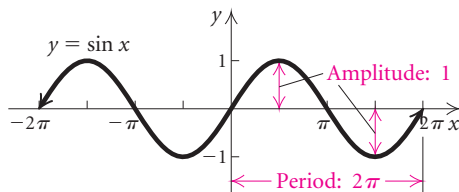

and

$$\text{the amplitude of the cosine function is } \frac{1}{2}|1 - (-1)| = 1.$$

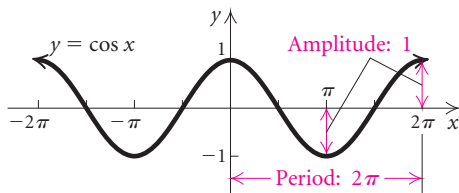

TECHNOLOGY CONNECTION

Using the TABLE feature on a graphing calculator, compare the y -values for $y_1 = \sin x$ and $y_2 = \sin(-x)$ and for $y_3 = \cos x$ and $y_4 = \cos(-x)$. We set TblStart = 0 and $\Delta\text{Tbl} = \pi/12$.

X	Y1	Y2
0	0	0
.2618	.25882	-.2588
.5236	.5	-.5
.7854	.70711	-.7071
1.0472	.86603	-.866
1.309	.96593	-.9659
1.5708	1	-1

X = 0

X	Y3	Y4
0	1	1
.2618	.96593	.96593
.5236	.86603	.86603
.7854	.70711	.70711
1.0472	.5	.5
1.309	.25882	.25882
1.5708	0	0

X = 0

What appears to be the relationship between $\sin x$ and $\sin(-x)$ and between $\cos x$ and $\cos(-x)$?

Consider any real number s and its opposite, $-s$. These numbers determine points T and T_1 on a unit circle that are symmetric with respect to the x -axis.

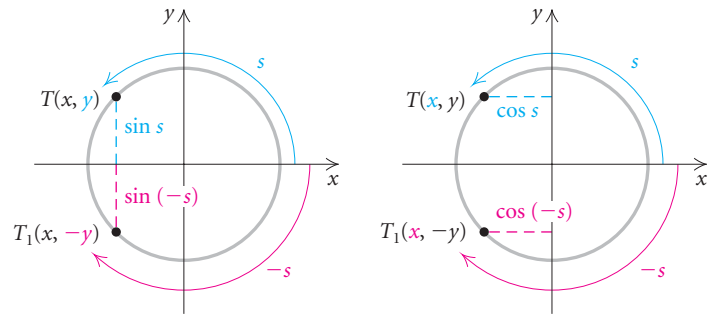

Because their second coordinates are opposites of each other, we know that for any number s ,

$$\sin(-s) = -\sin s.$$

Because their first coordinates are the same, we know that for any number s ,

$$\cos(-s) = \cos s.$$

Thus we have shown the following.

EVEN AND ODD FUNCTIONS

REVIEW SECTION 2.4

The sine function is *odd*.

The cosine function is *even*.

A summary of the properties of the sine function and the cosine function follows.

CONNECTING THE CONCEPTS

Comparing the Sine Function and the Cosine Function

SINE FUNCTION

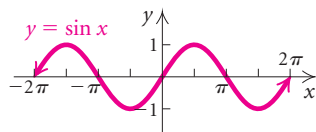

1. Continuous
2. Period: 2π
3. Domain: All real numbers
4. Range: $[-1, 1]$
5. Amplitude: 1
6. Odd: $\sin(-s) = -\sin s$

COSINE FUNCTION

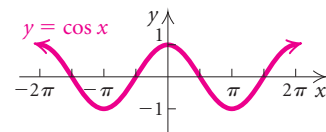

1. Continuous
2. Period: 2π
3. Domain: All real numbers
4. Range: $[-1, 1]$
5. Amplitude: 1
6. Even: $\cos(-s) = \cos s$

► Graphs of the Tangent, Cotangent, Cosecant, and Secant Functions

To graph the tangent function, we could make a table of values using a calculator, but in this case it is easier to begin with the definition of tangent and the coordinates of a few points on the unit circle. We recall that

$$\tan s = \frac{y}{x} = \frac{\sin s}{\cos s}.$$

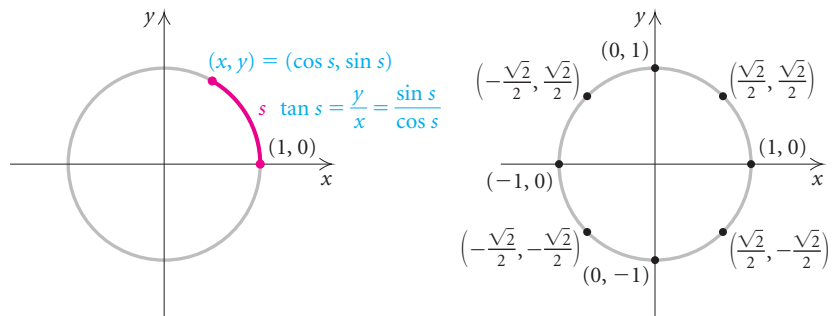

The tangent function is not defined when x , the first coordinate, is 0. That is, it is not defined for any number s whose cosine is 0:

$$s = \pm\frac{\pi}{2}, \pm\frac{3\pi}{2}, \pm\frac{5\pi}{2}, \dots$$

We draw vertical asymptotes at these locations (see Fig. 1 below).

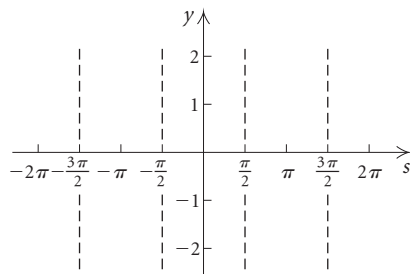

Figure 1

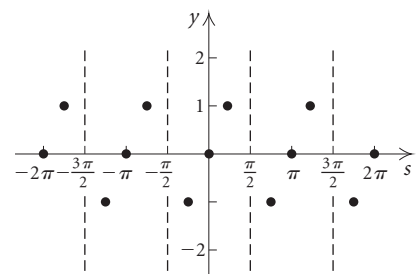

Figure 2

We also note that

$$\tan s = 0 \text{ at } s = 0, \pm\pi, \pm2\pi, \pm3\pi, \dots,$$

$$\tan s = 1 \text{ at } s = \dots -\frac{7\pi}{4}, -\frac{3\pi}{4}, \frac{\pi}{4}, \frac{5\pi}{4}, \frac{9\pi}{4}, \dots,$$

$$\tan s = -1 \text{ at } s = \dots -\frac{9\pi}{4}, -\frac{5\pi}{4}, -\frac{\pi}{4}, \frac{3\pi}{4}, \frac{7\pi}{4}, \dots$$

We can add these ordered pairs to the graph (see Fig. 2 above) and investigate the values in $(-\pi/2, \pi/2)$ using a calculator. Note that the function value is 0 when $s = 0$, and the values increase without bound as s increases toward $\pi/2$. The graph gets closer and closer to an asymptote as s gets closer to $\pi/2$, but it never touches the line. As s decreases from 0 to $-\pi/2$, the

values decrease without bound. Again the graph gets closer and closer to an asymptote, but it never touches it. We now complete the graph.

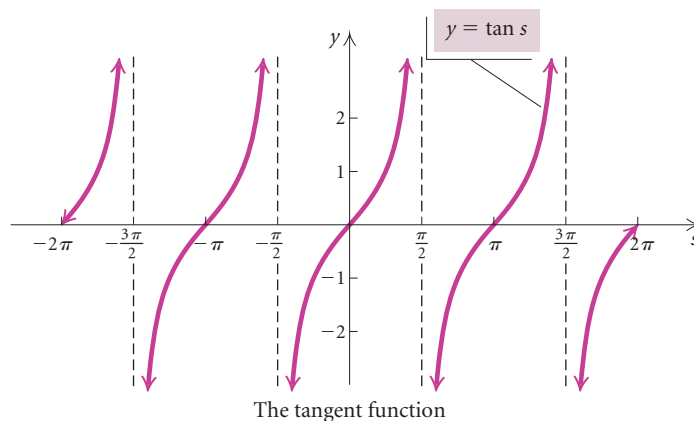

TECHNOLOGY CONNECTION

When graphing trigonometric functions that are not defined for all real numbers, it is best to use DOT mode for the graph. Here we illustrate $y = \tan x$ and $y = \csc x$.

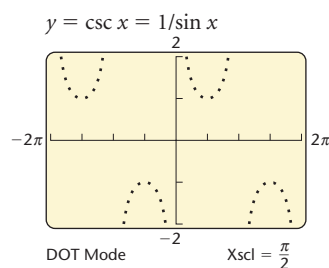
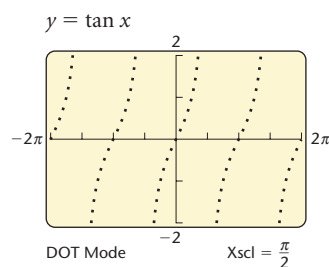

From the graph, we see that the tangent function is continuous except where it is not defined. The period of the tangent function is π . Note that although there is a period, there is no amplitude because there are no maximum and minimum values. When $\cos s = 0$, $\tan s$ is not defined ($\tan s = \sin s / \cos s$). Thus the domain of the tangent function is the set of all real numbers except $(\pi/2) + k\pi$, where k is an integer. The range of the function is the set of all real numbers.

The cotangent function ($\cot s = \cos s / \sin s$) is not defined when y , the second coordinate, is 0—that is, it is not defined for any number s whose sine is 0. Thus the cotangent is not defined for $s = 0, \pm\pi, \pm2\pi, \pm3\pi, \dots$. The graph of the function is shown below.

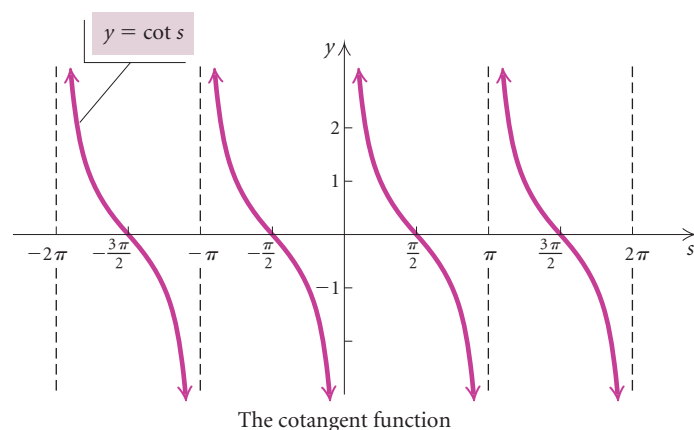

The cosecant and sine functions are reciprocal functions, as are the secant and cosine functions. The graphs of the cosecant and secant functions can be constructed by finding the reciprocals of the values of the sine and cosine functions, respectively. Thus the functions will be positive together and negative together. The cosecant function is not defined for those numbers s whose sine is 0. The secant function is not defined for those

numbers s whose cosine is 0. In the graphs below, the sine and cosine functions are shown by the gray curves for reference.

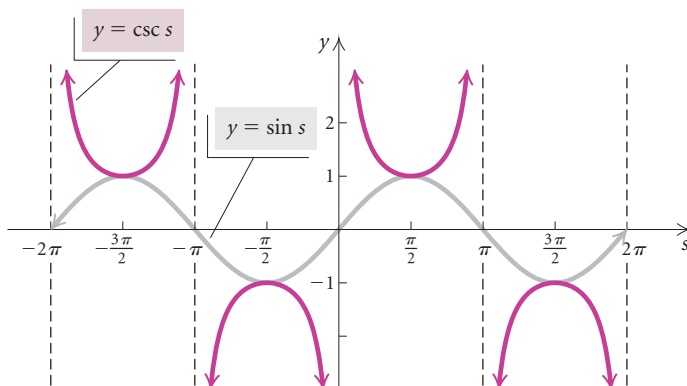

The cosecant function

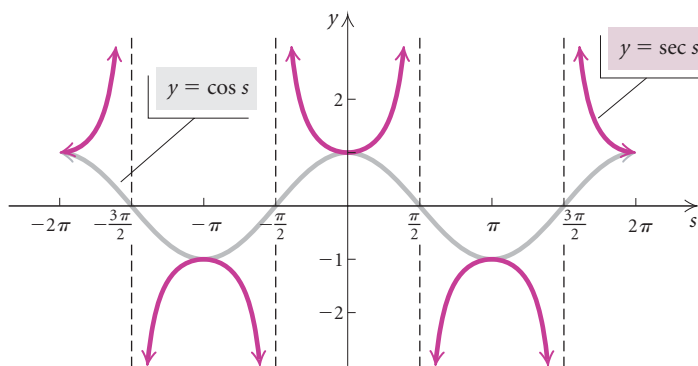

The secant function

The following is a summary of the basic properties of the tangent, cotangent, cosecant, and secant functions. These functions are continuous except where they are not defined.

CONNECTING THE CONCEPTS

Comparing the Tangent, Cotangent, Cosecant, and Secant Functions

TANGENT FUNCTION

1. Period: π
2. Domain: All real numbers except $(\pi/2) + k\pi$, where k is an integer
3. Range: All real numbers

COSECANT FUNCTION

1. Period: 2π
2. Domain: All real numbers except $k\pi$, where k is an integer
3. Range: $(-\infty, -1] \cup [1, \infty)$

COTANGENT FUNCTION

1. Period: π
2. Domain: All real numbers except $k\pi$, where k is an integer
3. Range: All real numbers

SECANT FUNCTION

1. Period: 2π
2. Domain: All real numbers except $(\pi/2) + k\pi$, where k is an integer
3. Range: $(-\infty, -1] \cup [1, \infty)$

In this chapter, we have used the letter s for arc length and have avoided the letters x and y , which generally represent first and second coordinates. Nevertheless, we can represent the arc length on a unit circle by any variable, such as s , t , x , or θ . Each arc length determines a point that can be labeled with an ordered pair. The first coordinate of that ordered pair is the cosine of the arc length, and the second coordinate is the sine of the arc length. The identities we have developed hold no matter what symbols are used for variables—for example, $\cos(-s) = \cos s$, $\cos(-x) = \cos x$, $\cos(-\theta) = \cos \theta$, and $\cos(-t) = \cos t$.

6.5

Exercise Set

The following points are on the unit circle. Find the coordinates of their reflections across (a) the x -axis, (b) the y -axis, and (c) the origin.

- $\left(-\frac{3}{4}, \frac{\sqrt{7}}{4}\right)$
- $\left(\frac{2}{3}, \frac{\sqrt{5}}{3}\right)$
- $\left(\frac{2}{5}, -\frac{\sqrt{21}}{5}\right)$
- $\left(-\frac{\sqrt{3}}{2}, -\frac{1}{2}\right)$

- The number $\pi/4$ determines a point on the unit circle with coordinates $(\sqrt{2}/2, \sqrt{2}/2)$. What are the coordinates of the point determined by $-\pi/4$?
- A number β determines a point on the unit circle with coordinates $(-2/3, \sqrt{5}/3)$. What are the coordinates of the point determined by $-\beta$?

Find the function value using coordinates of points on the unit circle. Give exact answers.

- $\sin \pi$
- $\cos\left(-\frac{\pi}{3}\right)$
- $\cot \frac{7\pi}{6}$
- $\tan \frac{11\pi}{4}$
- $\sin(-3\pi)$
- $\csc \frac{3\pi}{4}$
- $\cos \frac{5\pi}{6}$
- $\tan\left(-\frac{\pi}{4}\right)$
- $\sec \frac{\pi}{2}$
- $\cos 10\pi$
- $\cos \frac{\pi}{6}$
- $\sin \frac{2\pi}{3}$
- $\sin \frac{5\pi}{4}$
- $\cos \frac{11\pi}{6}$

- $\sin(-5\pi)$
- $\tan \frac{3\pi}{2}$
- $\cot \frac{5\pi}{2}$
- $\tan \frac{5\pi}{3}$

Find the function value using a calculator set in RADIAN mode. Round the answer to four decimal places, where appropriate.

- $\tan \frac{\pi}{7}$
- $\cos\left(-\frac{2\pi}{5}\right)$
- $\sec 37$
- $\sin 11.7$
- $\cot 342$
- $\tan 1.3$
- $\cos 6\pi$
- $\sin \frac{\pi}{10}$
- $\csc 4.16$
- $\sec \frac{10\pi}{7}$
- $\tan \frac{7\pi}{4}$
- $\cos 2000$
- $\sin\left(-\frac{\pi}{4}\right)$
- $\cot 7\pi$
- $\sin 0$
- $\cos(-29)$
- $\tan \frac{2\pi}{9}$
- $\sin \frac{8\pi}{3}$
- Sketch a graph of $y = \sin x$.
 - By reflecting the graph in part (a), sketch a graph of $y = \sin(-x)$.

- c) By reflecting the graph in part (a), sketch a graph of $y = -\sin x$.
- d) How do the graphs in parts (b) and (c) compare?
44. a) Sketch a graph of $y = \cos x$.
- b) By reflecting the graph in part (a), sketch a graph of $y = \cos(-x)$.
- c) By reflecting the graph in part (a), sketch a graph of $y = -\cos x$.
- d) How do the graphs in parts (a) and (b) compare?
45. a) Sketch a graph of $y = \sin x$.
- b) By translating, sketch a graph of $y = \sin(x + \pi)$.
- c) By reflecting the graph of part (a), sketch a graph of $y = -\sin x$.
- d) How do the graphs of parts (b) and (c) compare?
46. a) Sketch a graph of $y = \sin x$.
- b) By translating, sketch a graph of $y = \sin(x - \pi)$.
- c) By reflecting the graph of part (a), sketch a graph of $y = -\sin x$.
- d) How do the graphs of parts (b) and (c) compare?
47. a) Sketch a graph of $y = \cos x$.
- b) By translating, sketch a graph of $y = \cos(x + \pi)$.
- c) By reflecting the graph of part (a), sketch a graph of $y = -\cos x$.
- d) How do the graphs of parts (b) and (c) compare?
48. a) Sketch a graph of $y = \cos x$.
- b) By translating, sketch a graph of $y = \cos(x - \pi)$.
- c) By reflecting the graph of part (a), sketch a graph of $y = -\cos x$.
- d) How do the graphs of parts (b) and (c) compare?
49. a) Sketch a graph of $y = \tan x$.
- b) By reflecting the graph of part (a), sketch a graph of $y = \tan(-x)$.
- c) By reflecting the graph of part (a), sketch a graph of $y = -\tan x$.
- d) How do the graphs of parts (b) and (c) compare?
50. a) Sketch a graph of $y = \sec x$.
- b) By reflecting the graph of part (a), sketch a graph of $y = \sec(-x)$.
- c) By reflecting the graph of part (a), sketch a graph of $y = -\sec x$.
- d) How do the graphs of parts (a) and (b) compare?

51. Of the six circular functions, which are even? Which are odd?
52. Of the six circular functions, which have period π ? Which have period 2π ?

Consider the coordinates on the unit circle for Exercises 53–56.

53. In which quadrants is the tangent function positive? negative?
54. In which quadrants is the sine function positive? negative?
55. In which quadrants is the cosine function positive? negative?
56. In which quadrants is the cosecant function positive? negative?

Skill Maintenance

Graph both functions on the same set of axes and describe how g is a transformation of f .

57. $f(x) = x^2$, $g(x) = 2x^2 - 3$
58. $f(x) = x^2$, $g(x) = (x - 2)^2$
59. $f(x) = |x|$, $g(x) = \frac{1}{2}|x - 4| + 1$
60. $f(x) = x^3$, $g(x) = -x^3$

Write an equation for a function that has a graph with the given characteristics.

61. The shape of $y = x^3$, but reflected across the x -axis, shifted right 2 units, and shifted down 1 unit
62. The shape of $y = 1/x$, but shrunk vertically by a factor of $\frac{1}{4}$ and shifted up 3 units

Synthesis

Complete. (For example, $\sin(x + 2\pi) = \sin x$.)

63. $\cos(-x) = \underline{\hspace{2cm}}$
64. $\sin(-x) = \underline{\hspace{2cm}}$
65. $\sin(x + 2k\pi)$, $k \in \mathbb{Z} = \underline{\hspace{2cm}}$
66. $\cos(x + 2k\pi)$, $k \in \mathbb{Z} = \underline{\hspace{2cm}}$
67. $\sin(\pi - x) = \underline{\hspace{2cm}}$

68. $\cos(\pi - x) =$ _____
69. $\cos(x - \pi) =$ _____
70. $\cos(x + \pi) =$ _____
71. $\sin(x + \pi) =$ _____
72. $\sin(x - \pi) =$ _____
73. Find all numbers x that satisfy the following.
- $\sin x = 1$
 - $\cos x = -1$
 - $\sin x = 0$
74. Find $f \circ g$ and $g \circ f$, where $f(x) = x^2 + 2x$ and $g(x) = \cos x$.

Determine the domain of the function.

75. $f(x) = \sqrt{\cos x}$
76. $g(x) = \frac{1}{\sin x}$
77. $f(x) = \frac{\sin x}{\cos x}$
78. $g(x) = \log(\sin x)$

Graph.

79. $y = 3 \sin x$ 80. $y = \sin |x|$
81. $y = \sin x + \cos x$ 82. $y = |\cos x|$

83. One of the motivations for developing trigonometry with a unit circle is that you can actually “see” $\sin \theta$ and $\cos \theta$ on the circle. Note in the figure below that $AP = \sin \theta$ and $OA = \cos \theta$. It turns out that you can also “see” the other four trigonometric functions. Prove each of the following.

- $BD = \tan \theta$
- $OD = \sec \theta$
- $OE = \csc \theta$
- $CE = \cot \theta$

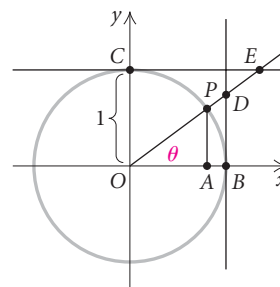

Graphs of Transformed Sine and Cosine Functions

6.6

- ▶ Graph transformations of $y = \sin x$ and $y = \cos x$ in the form

$$y = A \sin(Bx - C) + D$$
 and

$$y = A \cos(Bx - C) + D$$
 and determine the amplitude, the period, and the phase shift.
- ▶ Graph sums of functions.
- ▶ Graph functions (damped oscillations) found by multiplying trigonometric functions by other functions.

▶ Variations of Basic Graphs

In Section 6.5, we graphed all six trigonometric functions. In this section, we will consider variations of the graphs of the sine and cosine functions. For example, we will graph equations like the following:

$$y = 5 \sin \frac{1}{2}x, \quad y = \cos(2x - \pi), \quad \text{and} \quad y = \frac{1}{2} \sin x - 3.$$

In particular, we are interested in graphs of functions in the form

$$y = A \sin(Bx - C) + D$$

and

$$y = A \cos(Bx - C) + D,$$

where A , B , C , and D are constants. These constants have the effect of translating, reflecting, stretching, and shrinking the basic graphs. Let's first examine the effect of each constant individually. Then we will consider the combined effects of more than one constant.

TRANSFORMATIONS OF FUNCTIONS

REVIEW SECTION 2.4

The Constant D . Let's observe the effect of the constant D in the graphs below.

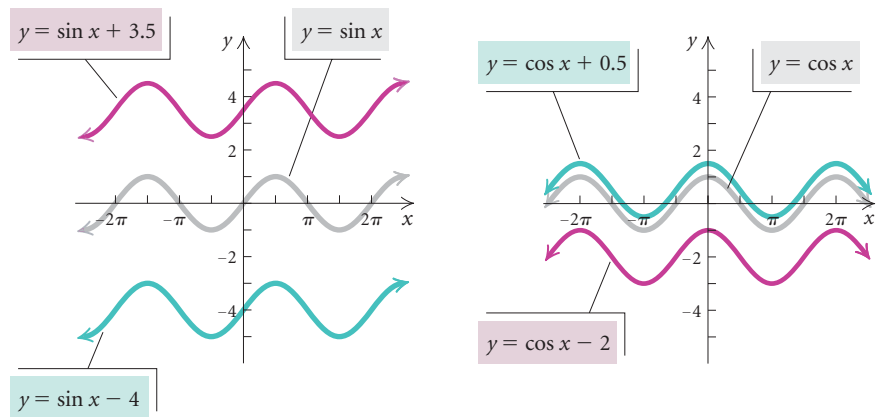

The constant D in

$$y = A \sin(Bx - C) + D \quad \text{and} \quad y = A \cos(Bx - C) + D$$

translates the graphs up D units if $D > 0$ or down $|D|$ units if $D < 0$.

EXAMPLE 1 Sketch a graph of $y = \sin x + 3$.

Solution The graph of $y = \sin x + 3$ is a *vertical* translation of the graph of $y = \sin x$ up 3 units. One way to sketch the graph is to first consider $y = \sin x$ on an interval of length 2π , say, $[0, 2\pi]$. The zeros of the function and the maximum and minimum values can be considered key points. These are

$$(0, 0), \quad \left(\frac{\pi}{2}, 1\right), \quad (\pi, 0), \quad \left(\frac{3\pi}{2}, -1\right), \quad (2\pi, 0).$$

These key points are transformed up 3 units to obtain the key points of the graph of $y = \sin x + 3$. These are

$$(0, 3), \quad \left(\frac{\pi}{2}, 4\right), \quad (\pi, 3), \quad \left(\frac{3\pi}{2}, 2\right), \quad (2\pi, 3).$$

The graph of $y = \sin x + 3$ can be sketched on the interval $[0, 2\pi]$ and extended to obtain the rest of the graph by repeating the graph on intervals of length 2π .

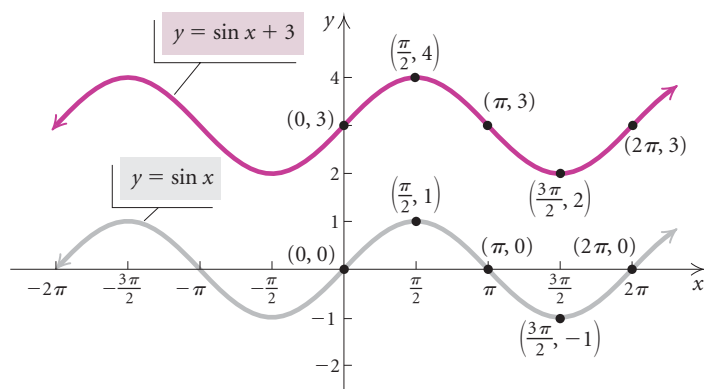

The Constant A. Next, we consider the effect of the constant A . What can we observe in the following graphs? What is the effect of the constant A on the graph of the basic function when (a) $0 < A < 1$? (b) $A > 1$? (c) $-1 < A < 0$? (d) $A < -1$?

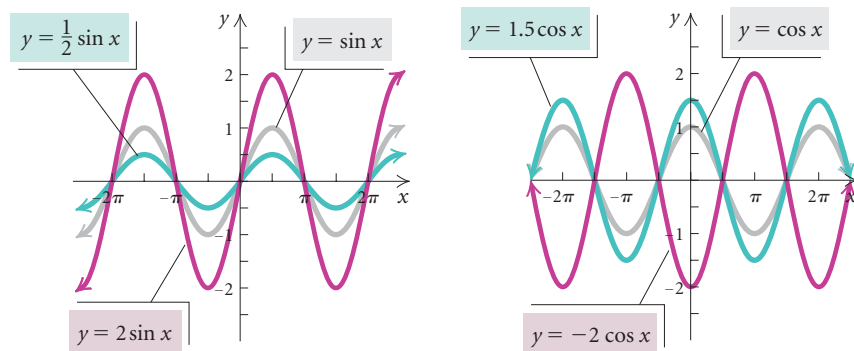

If $|A| > 1$, then there will be a vertical stretching. If $|A| < 1$, then there will be a vertical shrinking. If $A < 0$, the graph is also reflected across the x -axis.

Amplitude

The **amplitude** of the graphs of $y = A \sin(Bx - C) + D$ and $y = A \cos(Bx - C) + D$ is $|A|$.

EXAMPLE 2 Sketch a graph of $y = 2 \cos x$. What is the amplitude?

Solution The constant 2 in $y = 2 \cos x$ has the effect of stretching the graph of $y = \cos x$ vertically by a factor of 2. Since the function values of $y = \cos x$ are such that $-1 \leq \cos x \leq 1$, the function values of $y = 2 \cos x$ are such

that $-2 \leq 2 \cos x \leq 2$. The maximum value of $y = 2 \cos x$ is 2, and the minimum value is -2 . Thus the *amplitude*, A , is $\frac{1}{2}|2 - (-2)|$, or 2.

We draw the graph of $y = \cos x$ and consider its key points,

$$(0, 1), \left(\frac{\pi}{2}, 0\right), (\pi, -1), \left(\frac{3\pi}{2}, 0\right), (2\pi, 1),$$

on the interval $[0, 2\pi]$.

We then multiply the second coordinates by 2 to obtain the key points of $y = 2 \cos x$. These are

$$(0, 2), \left(\frac{\pi}{2}, 0\right), (\pi, -2), \left(\frac{3\pi}{2}, 0\right), (2\pi, 2).$$

We plot these points and sketch the graph on the interval $[0, 2\pi]$. Then we repeat this part of the graph on adjacent intervals of length 2π .

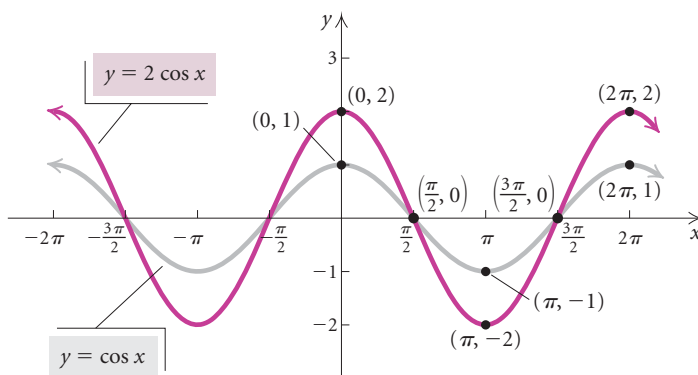

EXAMPLE 3 Sketch a graph of $y = -\frac{1}{2} \sin x$. What is the amplitude?

Solution The amplitude of the graph is $|\frac{1}{2}|$, or $\frac{1}{2}$. The graph of $y = -\frac{1}{2} \sin x$ is a vertical shrinking and a reflection of the graph of $y = \sin x$ across the x -axis. In graphing, the key points of $y = \sin x$,

$$(0, 0), \left(\frac{\pi}{2}, 1\right), (\pi, 0), \left(\frac{3\pi}{2}, -1\right), (2\pi, 0),$$

are transformed to

$$(0, 0), \left(\frac{\pi}{2}, -\frac{1}{2}\right), (\pi, 0), \left(\frac{3\pi}{2}, \frac{1}{2}\right), (2\pi, 0).$$

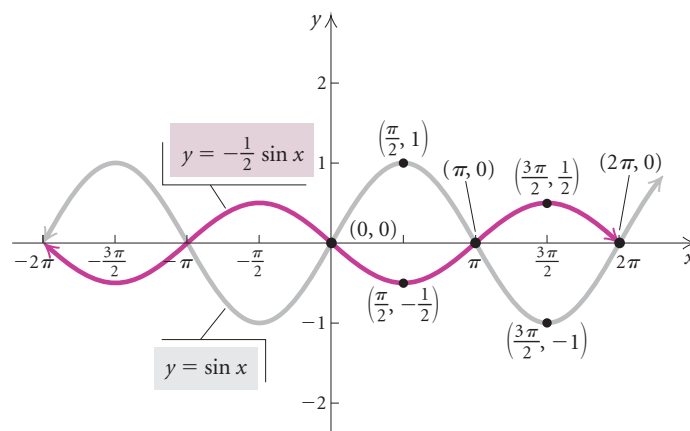

The Constant B . Now, we consider the effect of the constant B . Changes in the constants A and D *do not* change the period. But what effect, if any, does a change in B have on the period of the function? Let's observe the period of each of the following graphs.

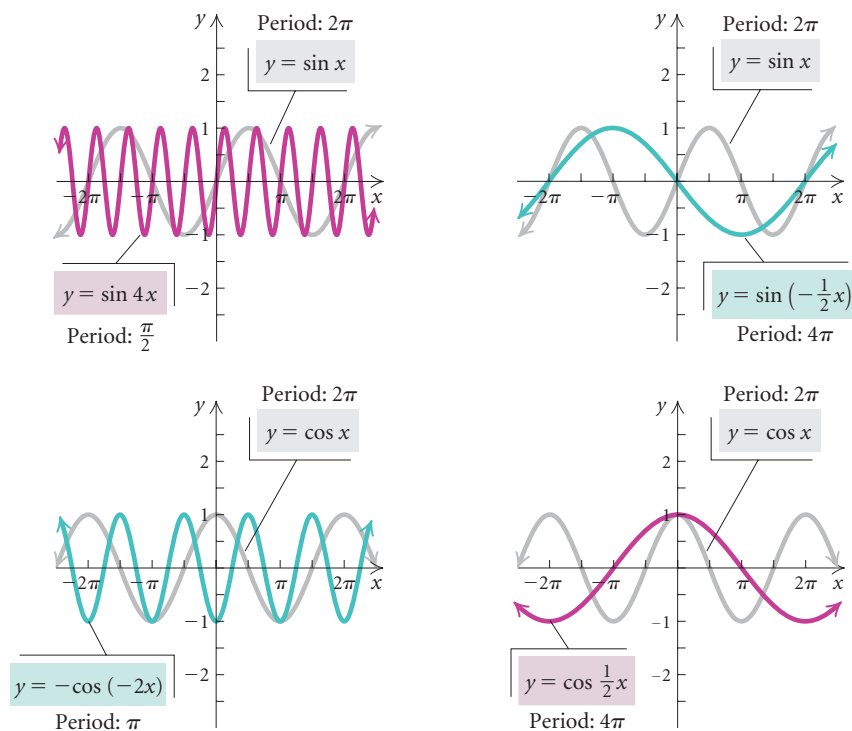

If $|B| < 1$, then there will be a horizontal stretching. If $|B| > 1$, then there will be a horizontal shrinking. If $B < 0$, the graph is also reflected across the y -axis.

Period

The **period** of the graphs of

$$y = A \sin(Bx - C) + D$$

and

$$y = A \cos(Bx - C) + D$$

is $\left| \frac{2\pi}{B} \right|$ *

EXAMPLE 4 Sketch a graph of $y = \sin 4x$. What is the period?

Solution The constant B has the effect of changing the period. The graph of $y = f(4x)$ is obtained from the graph of $y = f(x)$ by shrinking the graph horizontally. The period of $y = \sin 4x$ is $|2\pi/4|$, or $\pi/2$. The new graph is

*The period of the graphs of $y = A \tan(Bx - C) + D$ and $y = A \cot(Bx - C) + D$ is $|\pi/B|$. The period of the graphs of $y = A \sec(Bx - C) + D$ and $y = A \csc(Bx - C) + D$ is $|2\pi/B|$.

obtained by dividing the first coordinate of each ordered-pair solution of $y = f(x)$ by 4. The key points of $y = \sin x$ are

$$(0, 0), \left(\frac{\pi}{2}, 1\right), (\pi, 0), \left(\frac{3\pi}{2}, -1\right), (2\pi, 0).$$

These are transformed to the key points of $y = \sin 4x$, which are

$$(0, 0), \left(\frac{\pi}{8}, 1\right), \left(\frac{\pi}{4}, 0\right), \left(\frac{3\pi}{8}, -1\right), \left(\frac{\pi}{2}, 0\right).$$

We plot these key points and sketch in the graph on the shortened interval $[0, \pi/2]$. Then we repeat the graph on other intervals of length $\pi/2$.

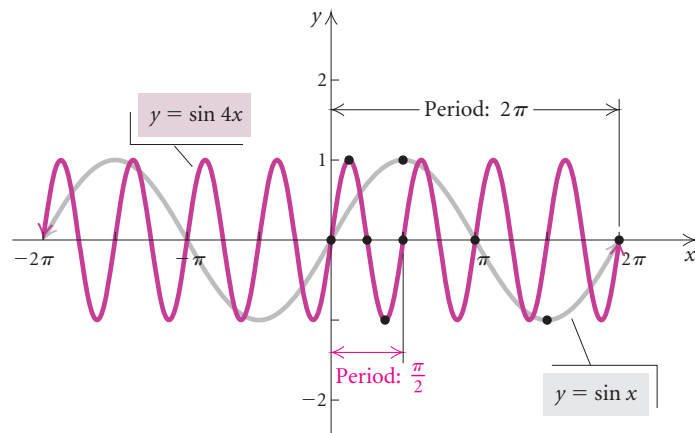

The Constant C. Next, we examine the effect of the constant C . The curve in each of the following graphs has an amplitude of 1 and a period of 2π , but there are six distinct graphs. What is the effect of the constant C ?

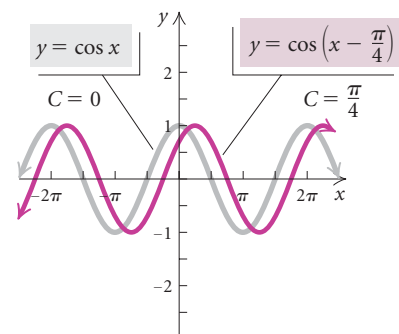
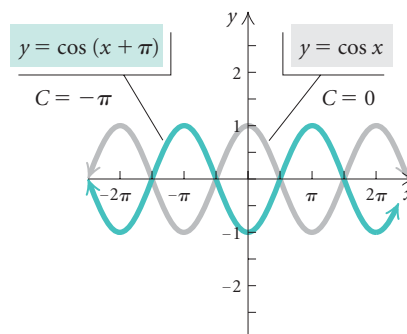
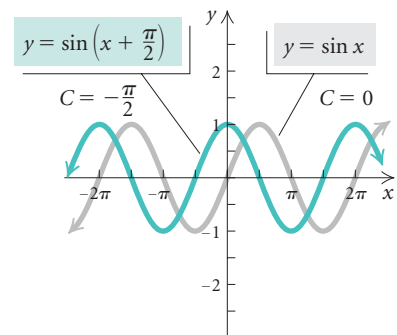
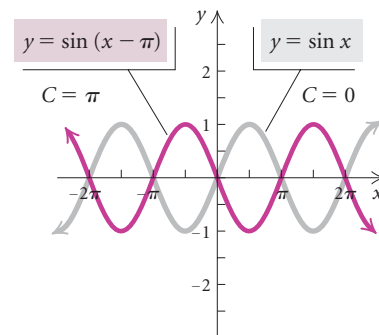

For each of the functions of the form

$$y = A \sin(Bx - C) + D \quad \text{and} \quad y = A \cos(Bx - C) + D$$

that are graphed on the preceding page, the coefficient of x , which is B , is 1. In this case, the effect of the constant C on the graph of the basic function is a horizontal translation of $|C|$ units. In Example 5, which follows, $B = 1$. We will consider functions where $B \neq 1$ in Examples 6 and 7. When $B \neq 1$, the horizontal translation will be $|C/B|$.

EXAMPLE 5 Sketch a graph of $y = \sin\left(x - \frac{\pi}{2}\right)$.

Solution The amplitude is 1, and the period is 2π . The graph of $y = f(x - c)$ is obtained from the graph of $y = f(x)$ by translating the graph horizontally—to the right c units if $c > 0$ and to the left $|c|$ units if $c < 0$. The graph of $y = \sin\left(x - \frac{\pi}{2}\right)$ is a translation of the graph of $y = \sin x$ to the right $\frac{\pi}{2}$ units. The value $\frac{\pi}{2}$ is called the **phase shift**. The key points of $y = \sin x$,

$$(0, 0), \quad \left(\frac{\pi}{2}, 1\right), \quad (\pi, 0), \quad \left(\frac{3\pi}{2}, -1\right), \quad (2\pi, 0),$$

are transformed by adding $\frac{\pi}{2}$ to each of the first coordinates to obtain the following key points of $y = \sin\left(x - \frac{\pi}{2}\right)$:

$$\left(\frac{\pi}{2}, 0\right), \quad (\pi, 1), \quad \left(\frac{3\pi}{2}, 0\right), \quad (2\pi, -1), \quad \left(\frac{5\pi}{2}, 0\right).$$

We plot these key points and sketch the curve on the interval $[\frac{\pi}{2}, 5\pi/2]$. Then we repeat the graph on other intervals of length 2π .

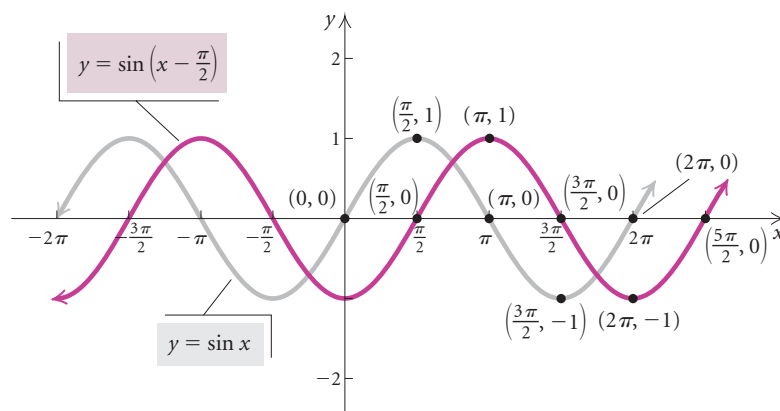

Combined Transformations. Now we consider combined transformations of graphs. It is helpful to rewrite

$$y = A \sin(Bx - C) + D \quad \text{and} \quad y = A \cos(Bx - C) + D$$

as

$$y = A \sin\left[B\left(x - \frac{C}{B}\right)\right] + D \quad \text{and} \quad y = A \cos\left[B\left(x - \frac{C}{B}\right)\right] + D.$$

EXAMPLE 6 Sketch a graph of $y = \cos(2x - \pi)$.

Solution The graph of

$$y = \cos(2x - \pi)$$

is the same as the graph of

$$y = 1 \cdot \cos \left[2 \left(x - \frac{\pi}{2} \right) \right] + 0.$$

The amplitude is 1. The factor 2 shrinks the period by half, making the period $|2\pi/2|$, or π . The phase shift $\pi/2$ translates the graph of $y = \cos 2x$ to the right $\pi/2$ units. Thus, to form the graph, we first graph $y = \cos x$, followed by $y = \cos 2x$ and then $y = \cos [2(x - \pi/2)]$.

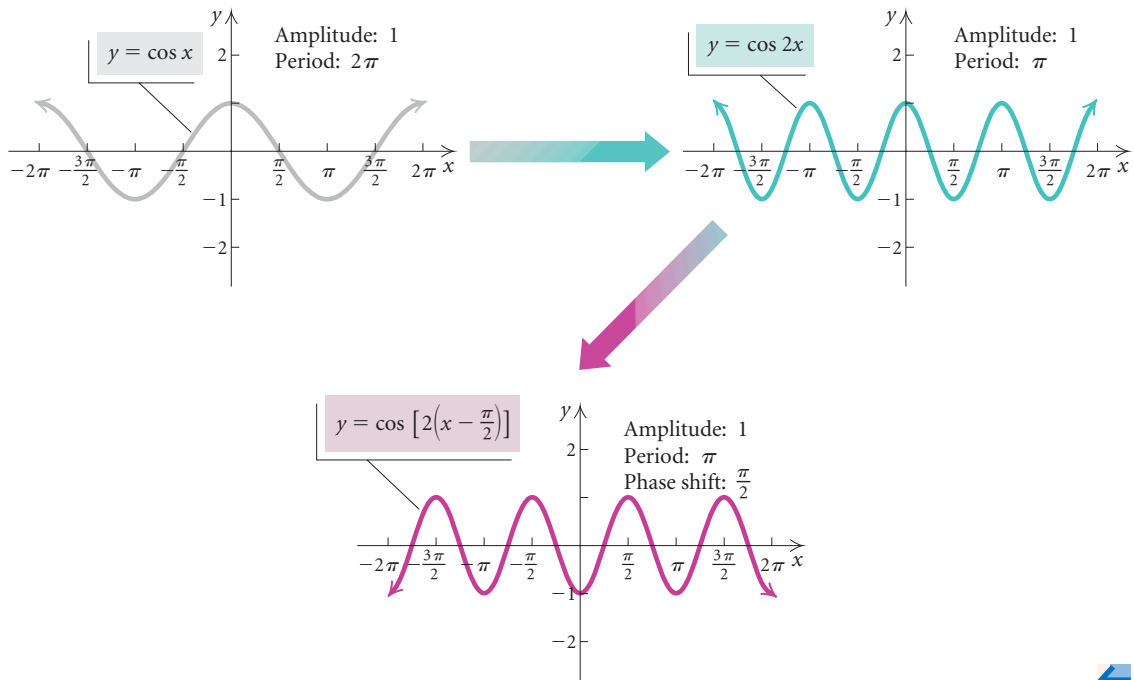

Phase Shift

The **phase shift** of the graphs

$$y = A \sin(Bx - C) + D = A \sin \left[B \left(x - \frac{C}{B} \right) \right] + D$$

and

$$y = A \cos(Bx - C) + D = A \cos \left[B \left(x - \frac{C}{B} \right) \right] + D$$

is the quantity $\frac{C}{B}$.

If $C/B > 0$, the graph is translated to the right C/B units. If $C/B < 0$, the graph is translated to the left $|C/B|$ units. Be sure that the horizontal stretching or shrinking based on the constant B is done before the translation based on the phase shift C/B .

Let's now summarize the effect of the constants. When graphing, we carry out the procedures in the order listed.

Transformations of Sine and Cosine Functions

To graph

$$y = A \sin (Bx - C) + D = A \sin \left[B \left(x - \frac{C}{B} \right) \right] + D$$

and

$$y = A \cos (Bx - C) + D = A \cos \left[B \left(x - \frac{C}{B} \right) \right] + D,$$

follow the steps listed below in the order in which they are listed.

1. Stretch or shrink the graph horizontally according to B .

$$|B| < 1 \quad \text{Stretch horizontally}$$

$$|B| > 1 \quad \text{Shrink horizontally}$$

$$B < 0 \quad \text{Reflect across the } y\text{-axis}$$

$$\text{The period is } \left| \frac{2\pi}{B} \right|.$$

2. Stretch or shrink the graph vertically according to A .

$$|A| < 1 \quad \text{Shrink vertically}$$

$$|A| > 1 \quad \text{Stretch vertically}$$

$$A < 0 \quad \text{Reflect across the } x\text{-axis}$$

$$\text{The amplitude is } |A|.$$

3. Translate the graph horizontally according to C/B .

$$\frac{C}{B} < 0 \quad \left| \frac{C}{B} \right| \text{ units to the left}$$

$$\frac{C}{B} > 0 \quad \frac{C}{B} \text{ units to the right}$$

$$\text{The phase shift is } \frac{C}{B}.$$

4. Translate the graph vertically according to D .

$$D < 0 \quad |D| \text{ units down}$$

$$D > 0 \quad D \text{ units up}$$

When graphing transformations of the tangent and cotangent functions, note that the period is $|\pi/B|$.

When graphing transformations of the secant and cosecant functions, note that the period is $|2\pi/B|$.

EXAMPLE 7 Sketch a graph of $y = 3 \sin (2x + \pi/2) + 1$. Find the amplitude, the period, and the phase shift.

Solution We first note that

$$y = 3 \sin \left(2x + \frac{\pi}{2} \right) + 1 = 3 \sin \left[2 \left(x - \left(-\frac{\pi}{4} \right) \right) \right] + 1.$$

Then we have the following:

$$\text{Amplitude} = |A| = |3| = 3,$$

$$\text{Period} = \left| \frac{2\pi}{B} \right| = \left| \frac{2\pi}{2} \right| = \pi,$$

$$\text{Phase shift} = \frac{C}{B} = \frac{-\pi/2}{2} = -\frac{\pi}{4}.$$

To create the final graph, we begin with the basic sine curve, $y = \sin x$. Then we sketch graphs of each of the following equations in sequence.

1. $y = \sin 2x$

2. $y = 3 \sin 2x$

3. $y = 3 \sin \left[2 \left(x - \left(-\frac{\pi}{4} \right) \right) \right]$

4. $y = 3 \sin \left[2 \left(x - \left(-\frac{\pi}{4} \right) \right) \right] + 1$

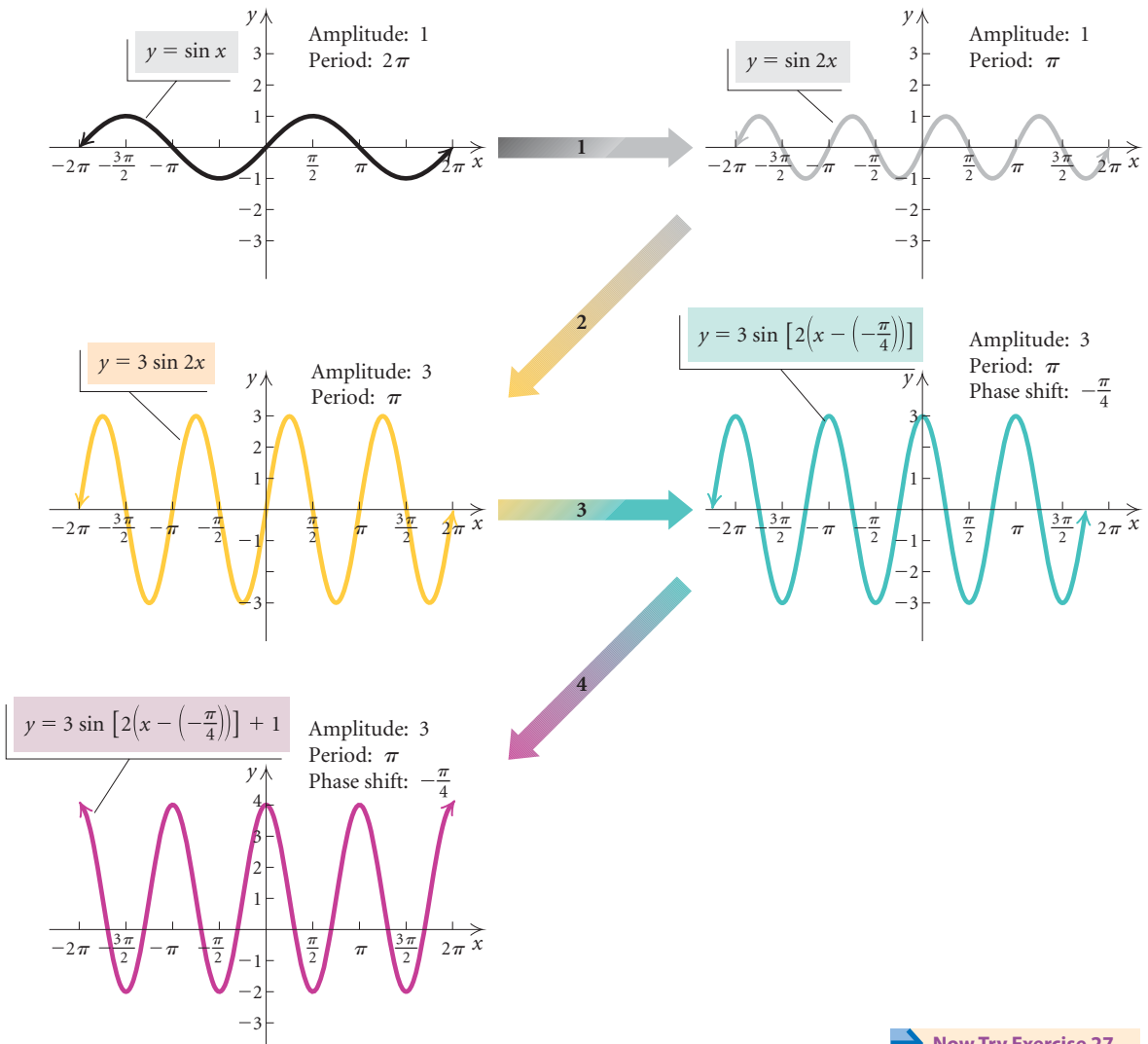

Now Try Exercise 27.

All the graphs in Examples 1–7 can be checked using a graphing calculator. Even though it is faster and more accurate to graph using a calculator, graphing by hand gives us a greater understanding of the effect of changing the constants A , B , C , and D .

Graphing calculators are especially convenient when a period or a phase shift is not a multiple of $\pi/4$.

EXAMPLE 8 Graph $y = 3 \cos 2\pi x - 1$. Find the amplitude, the period, and the phase shift.

Solution First we note the following:

$$\begin{aligned} \text{Amplitude} &= |A| \\ &= |3| = 3, \\ \text{Period} &= \left| \frac{2\pi}{B} \right| \\ &= \left| \frac{2\pi}{2\pi} \right| = |1| = 1, \\ \text{Phase shift} &= \frac{C}{B} \\ &= \frac{0}{2\pi} = 0. \end{aligned}$$

There is no phase shift in this case because the constant $C = 0$. The graph has a vertical translation of the graph of the cosine function down 1 unit, an amplitude of 3, and a period of 1, so we can use $[-4, 4, -5, 5]$ as the viewing window.

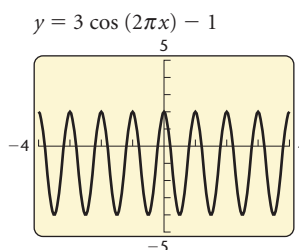

➔ Now Try Exercise 29.

The transformation techniques that we learned in this section for graphing the sine and cosine functions can also be applied in the same manner to the other trigonometric functions. Transformations of this type appear in the synthesis exercises in Exercise Set 6.6.

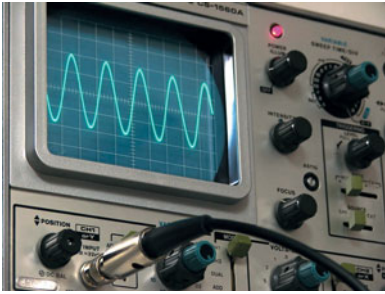

An **oscilloscope** is an electronic device that converts electrical signals into graphs like those in the preceding examples. These graphs are often called sine waves. By manipulating the controls, we can change the amplitude, the period, and the phase shift of sine waves. The oscilloscope has many applications, and the trigonometric functions play a major role in many of them.

► Graphs of Sums: Addition of Ordinates

The output of an electronic synthesizer used in the recording and playing of music can be converted into sine waves by an oscilloscope. The following graphs illustrate simple tones of different frequencies. The frequency of a simple tone is the number of vibrations in the signal of the tone per second. The loudness or intensity of the tone is reflected in the height of the graph (its amplitude). The three tones in the diagrams below all have the same intensity but different frequencies.

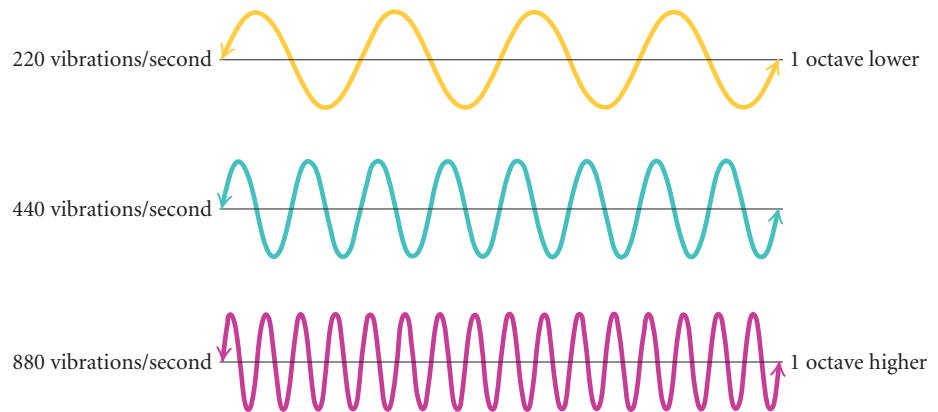

Musical instruments can generate extremely complex sine waves. On a single instrument, overtones can become superimposed on a simple tone. When multiple notes are played simultaneously, graphs become very complicated. This can happen when multiple notes are played on a single instrument or a group of instruments, or even when the same simple note is played on different instruments.

Combinations of simple tones produce interesting curves. Consider two tones whose graphs are $y_1 = 2 \sin x$ and $y_2 = \sin 2x$. The combination of the two tones produces a new sound whose graph is $y = 2 \sin x + \sin 2x$, as shown in the following example.

EXAMPLE 9 Graph: $y = 2 \sin x + \sin 2x$.

Solution We graph $y = 2 \sin x$ and $y = \sin 2x$ using the same set of axes.

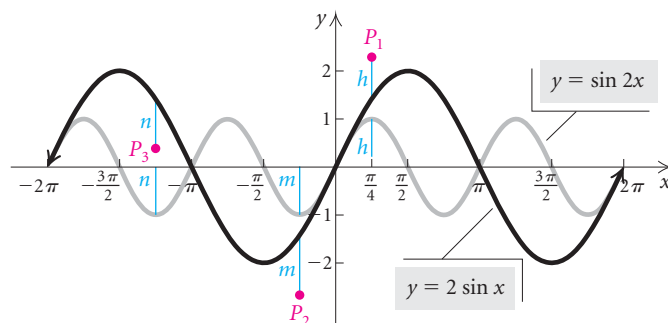

Now we graphically add some y -coordinates, or ordinates, to obtain points on the graph that we seek. At $x = \pi/4$, we transfer the distance h , which is the value of $\sin 2x$, up to add it to the value of $2 \sin x$. Point P_1 is on the graph that we seek. At $x = -\pi/4$, we use a similar procedure, but this time both ordinates are negative. Point P_2 is on the graph. At $x = -5\pi/4$, we add the negative ordinate of $\sin 2x$ to the positive ordinate of $2 \sin x$. Point P_3 is also on the graph. We continue to plot points in this fashion and then connect them to get the desired graph, shown below. This method is called **addition of ordinates**, because we add the y -values (ordinates) of $y = \sin 2x$ to the y -values (ordinates) of $y = 2 \sin x$. Note that the period of $2 \sin x$ is 2π and the period of $\sin 2x$ is π . The period of the sum $2 \sin x + \sin 2x$ is 2π , the least common multiple of 2π and π .

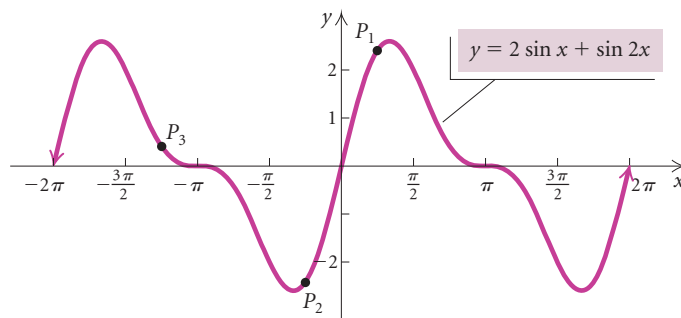

Now Try Exercise 45.

► Damped Oscillation: Multiplication of Ordinates

Suppose that a weight is attached to a spring and the spring is stretched and put into motion. The weight oscillates up and down. If we could assume falsely that the weight will bob up and down forever, then its height h after time t , in seconds, might be approximated by a function like

$$h(t) = 5 + 2 \sin(6\pi t).$$

Over a short time period, this might be a valid model, but experience tells us that eventually the spring will come to rest. A more appropriate model is provided by the following example, which illustrates **damped oscillation**.

EXAMPLE 10 Sketch a graph of $f(x) = e^{-x/2} \sin x$.

Solution The function f is the product of two functions g and h , where

$$g(x) = e^{-x/2} \quad \text{and} \quad h(x) = \sin x.$$

Thus, to find function values, we can **multiply ordinates**. Let's do more analysis before graphing. Note that for any real number x ,

$$-1 \leq \sin x \leq 1.$$

Recall from Chapter 5 that all values of the exponential function are positive. Thus we can multiply by $e^{-x/2}$ and obtain the inequality

$$-e^{-x/2} \leq e^{-x/2} \sin x \leq e^{-x/2}.$$

The direction of the inequality symbols does not change since $e^{-x/2} > 0$. This also tells us that the original function crosses the x -axis only at values for which $\sin x = 0$. These are the numbers $k\pi$, for any integer k .

The inequality tells us that the function f is constrained between the graphs of $y = -e^{-x/2}$ and $y = e^{-x/2}$. We start by graphing these functions using dashed lines. Since we also know that $f(x) = 0$ when $x = k\pi$, k an integer, we mark these points on the graph. Then we use a calculator and compute other function values. The graph is as follows.

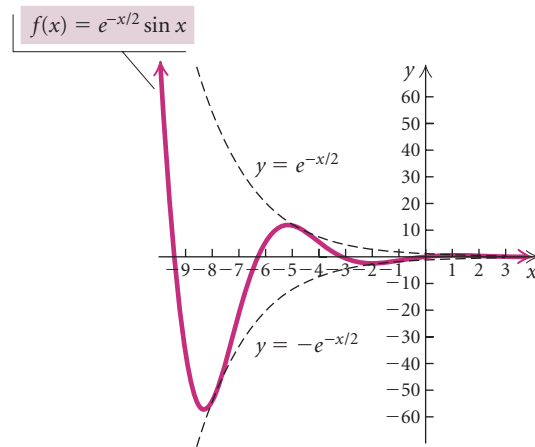

 Now Try Exercise 53.

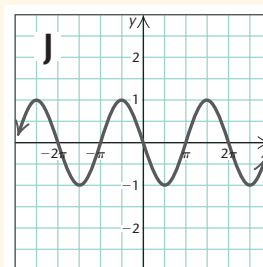
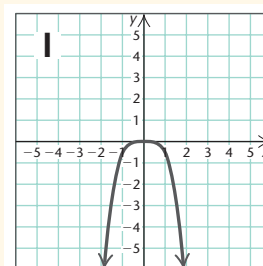
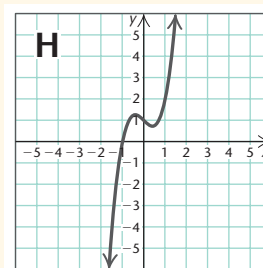
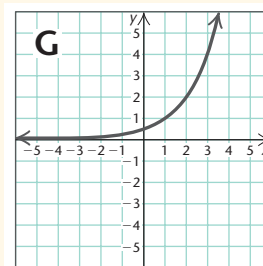
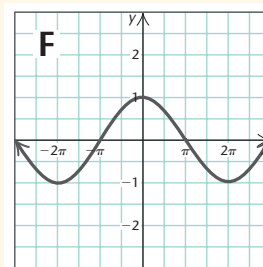
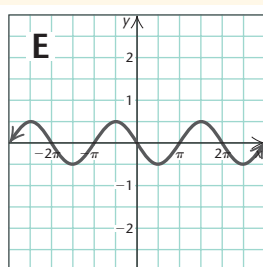
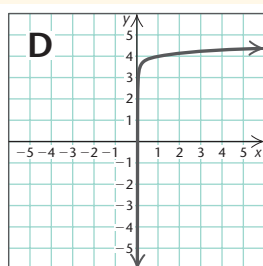
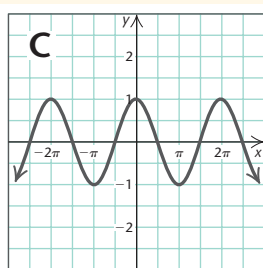
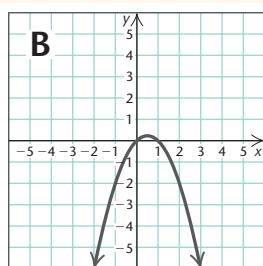
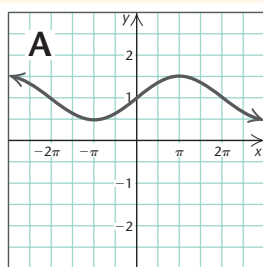

Visualizing the Graph

Match the function with its graph.

- $f(x) = -\sin x$
- $f(x) = 2x^3 - x + 1$
- $y = \frac{1}{2} \cos\left(x + \frac{\pi}{2}\right)$
- $f(x) = \cos\left(\frac{1}{2}x\right)$
- $y = -x^2 + x$
- $y = \frac{1}{2} \log x + 4$
- $f(x) = 2^{x-1}$
- $f(x) = \frac{1}{2} \sin\left(\frac{1}{2}x\right) + 1$
- $f(x) = -\cos(x - \pi)$
- $f(x) = -\frac{1}{2}x^4$

Answers on page A-39

6.6

Exercise Set

Determine the amplitude, the period, and the phase shift of the function and sketch the graph of the function.

1. $y = \sin x + 1$

2. $y = \frac{1}{4} \cos x$

3. $y = -3 \cos x$

4. $y = \sin(-2x)$

5. $y = \frac{1}{2} \cos x$

6. $y = \sin\left(\frac{1}{2}x\right)$

7. $y = \sin(2x)$

8. $y = \cos x - 1$

9. $y = 2 \sin\left(\frac{1}{2}x\right)$

10. $y = \cos\left(x - \frac{\pi}{2}\right)$

11. $y = \frac{1}{2} \sin\left(x + \frac{\pi}{2}\right)$

12. $y = \cos x - \frac{1}{2}$

13. $y = 3 \cos(x - \pi)$

14. $y = -\sin\left(\frac{1}{4}x\right) + 1$

15. $y = \frac{1}{3} \sin x - 4$

16. $y = \cos\left(\frac{1}{2}x + \frac{\pi}{2}\right)$

17. $y = -\cos(-x) + 2$

18. $y = \frac{1}{2} \sin\left(2x - \frac{\pi}{4}\right)$

Determine the amplitude, the period, and the phase shift of the function.

19. $y = 2 \cos\left(\frac{1}{2}x - \frac{\pi}{2}\right)$

20. $y = 4 \sin\left(\frac{1}{4}x + \frac{\pi}{8}\right)$

21. $y = -\frac{1}{2} \sin\left(2x + \frac{\pi}{2}\right)$

22. $y = -3 \cos(4x - \pi) + 2$

23. $y = 2 + 3 \cos(\pi x - 3)$

24. $y = 5 - 2 \cos\left(\frac{\pi}{2}x + \frac{\pi}{2}\right)$

25. $y = -\frac{1}{2} \cos(2\pi x) + 2$

26. $y = -2 \sin(-2x + \pi) - 2$

27. $y = -\sin\left(\frac{1}{2}x - \frac{\pi}{2}\right) + \frac{1}{2}$

28. $y = \frac{1}{3} \cos(-3x) + 1$

29. $y = \cos(-2\pi x) + 2$

30. $y = \frac{1}{2} \sin(2\pi x + \pi)$

31. $y = -\frac{1}{4} \cos(\pi x - 4)$

32. $y = 2 \sin(2\pi x + 1)$

In Exercises 33–40, match the function with one of the graphs (a)–(h), which follow.

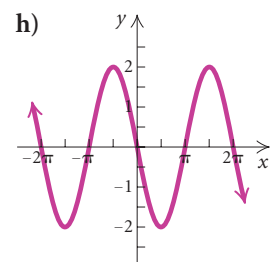
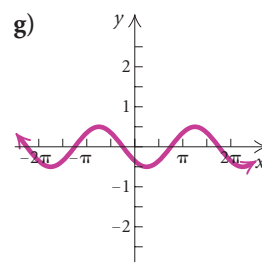
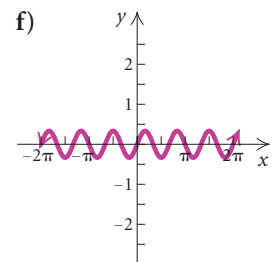
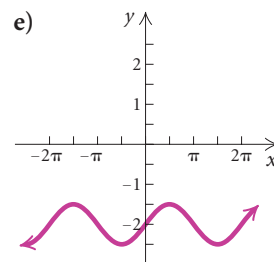
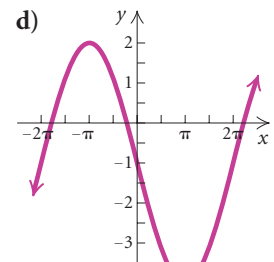
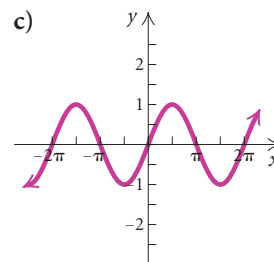
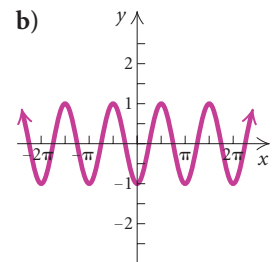
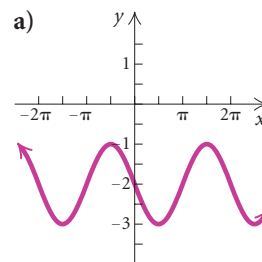

33. $y = -\cos 2x$

35. $y = 2 \cos \left(x + \frac{\pi}{2} \right)$

37. $y = \sin (x - \pi) - 2$

38. $y = -\frac{1}{2} \cos \left(x - \frac{\pi}{4} \right)$

39. $y = \frac{1}{3} \sin 3x$

34. $y = \frac{1}{2} \sin x - 2$

36. $y = -3 \sin \frac{1}{2}x - 1$

40. $y = \cos \left(x - \frac{\pi}{2} \right)$

In Exercises 41–44, determine the equation of the function that is graphed.

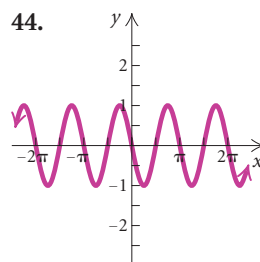
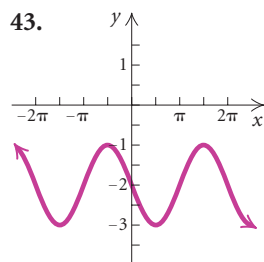
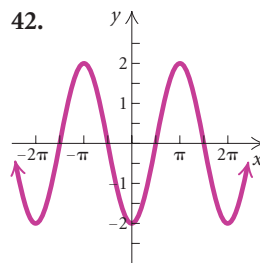
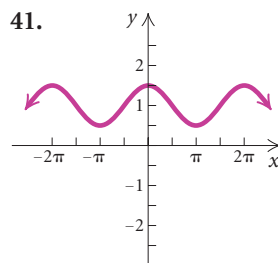

Graph using addition of ordinates.

45. $y = 2 \cos x + \cos 2x$

47. $y = \sin x + \cos 2x$

49. $y = \sin x - \cos x$

51. $y = 3 \cos x + \sin 2x$

46. $y = 3 \cos x + \cos 3x$

48. $y = 2 \sin x + \cos 2x$

50. $y = 3 \cos x - \sin x$

52. $y = 3 \sin x - \cos 2x$

Graph each of the following.

53. $f(x) = e^{-x/2} \cos x$

55. $f(x) = 0.6x^2 \cos x$

57. $f(x) = x \sin x$

59. $f(x) = 2^{-x} \sin x$

54. $f(x) = e^{-0.4x} \sin x$

56. $f(x) = e^{-x/4} \sin x$

58. $f(x) = |x| \cos x$

60. $f(x) = 2^{-x} \cos x$

Skill Maintenance

Classify the function as linear, quadratic, cubic, quartic, rational, exponential, logarithmic, or trigonometric.

61. $f(x) = \frac{x+4}{x}$

63. $y = x^4 - x - 2$

65. $f(x) = \sin x - 3$

67. $y = \frac{2}{5}$

69. $y = x^2 - x^3$

62. $y = \frac{1}{2} \log x - 4$

64. $\frac{3}{4}x + \frac{1}{2}y = -5$

66. $f(x) = 0.5e^{x-2}$

68. $y = \sin x + \cos x$

70. $f(x) = \left(\frac{1}{2}\right)^x$

Synthesis

Find the maximum and minimum values of the function.

71. $y = 2 \cos \left[3 \left(x - \frac{\pi}{2} \right) \right] + 6$

72. $y = \frac{1}{2} \sin (2x - 6\pi) - 4$

The transformation techniques that we learned in this section for graphing the sine and cosine functions can also be applied to the other trigonometric functions. Sketch a graph of each of the following.

73. $y = -\tan x$

75. $y = -2 + \cot x$

77. $y = 2 \tan \frac{1}{2}x$

79. $y = 2 \sec (x - \pi)$

80. $y = 4 \tan \left(\frac{1}{4}x + \frac{\pi}{8} \right)$

81. $y = 2 \csc \left(\frac{1}{2}x - \frac{3\pi}{4} \right)$

82. $y = 4 \sec (2x - \pi)$

74. $y = \tan (-x)$

76. $y = -\frac{3}{2} \csc x$

78. $y = \cot 2x$

83. **Satellite Location.** A satellite circles the earth in such a way that it is y miles from the equator (north or south, height not considered) t minutes after its launch, where

$$y(t) = 3000 \left[\cos \frac{\pi}{45} (t - 10) \right].$$

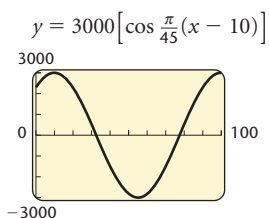
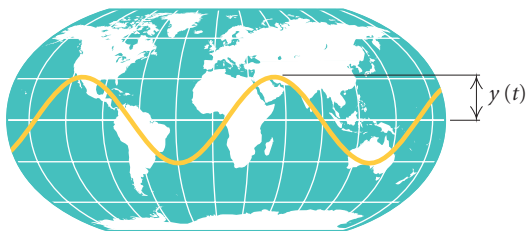

What are the amplitude, the period, and the phase shift?

84. **Water Wave.** The cross-section of a water wave is given by

$$y = 3 \sin \left(\frac{\pi}{4} x + \frac{\pi}{4} \right),$$

where y is the vertical height of the water wave and x is the distance from the origin to the wave.

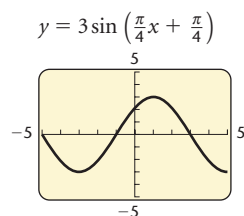

What are the amplitude, the period, and the phase shift?

85. **Damped Oscillations.** Suppose that the motion of a spring is given by

$$d(t) = 6e^{-0.8t} \cos(6\pi t) + 4,$$

where d is the distance, in inches, of a weight from the point at which the spring is attached to a ceiling, after t seconds. How far do you think the spring is from the ceiling when the spring stops bobbing?

86. **Rotating Beacon.** A police car is parked 10 ft from a wall. On top of the car is a beacon rotating in such a way that the light is at a distance $d(t)$ from point Q after t seconds, where

$$d(t) = 10 \tan(2\pi t).$$

When d is positive, as shown in the figure, the light is pointing north of Q , and when d is negative, the light is pointing south of Q .

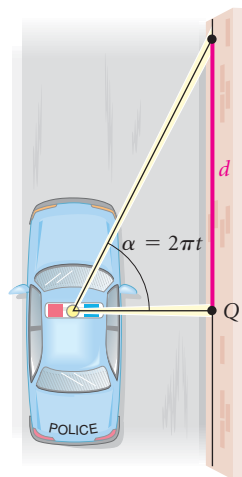

Explain the meaning of the values of t for which the function is not defined.

Chapter 6 Summary and Review

STUDY GUIDE

KEY TERMS AND CONCEPTS

EXAMPLES

SECTION 6.1: TRIGONOMETRIC FUNCTIONS OF ACUTE ANGLES

Trigonometric Function Values of an Acute Angle θ

Let θ be an acute angle of a right triangle. The six trigonometric functions of θ are as follows:

$$\begin{aligned} \sin \theta &= \frac{\text{opp}}{\text{hyp}}, & \csc \theta &= \frac{\text{hyp}}{\text{opp}}, \\ \cos \theta &= \frac{\text{adj}}{\text{hyp}}, & \sec \theta &= \frac{\text{hyp}}{\text{adj}}, \\ \tan \theta &= \frac{\text{opp}}{\text{adj}}, & \cot \theta &= \frac{\text{adj}}{\text{opp}}. \end{aligned}$$

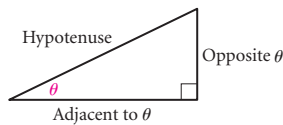

Reciprocal Functions

$$\csc \theta = \frac{1}{\sin \theta}, \quad \sec \theta = \frac{1}{\cos \theta}, \quad \cot \theta = \frac{1}{\tan \theta}$$

Function Values of Special Angles

We often use the function values of 30° , 45° , and 60° . Either the triangles below or the values themselves should be memorized.

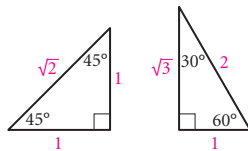

	30°	45°	60°
sin	$1/2$	$\sqrt{2}/2$	$\sqrt{3}/2$
cos	$\sqrt{3}/2$	$\sqrt{2}/2$	$1/2$
tan	$\sqrt{3}/3$	1	$\sqrt{3}$

If $\cos \alpha = \frac{3}{8}$ and α is an acute angle, find the other five trigonometric function values of α .

$$\cos \alpha = \frac{3}{8} \begin{matrix} \leftarrow \text{adj} \\ \leftarrow \text{hyp} \end{matrix}$$



We find the missing length using the Pythagorean equation: $a^2 + b^2 = c^2$.

$$\begin{aligned} a^2 + 3^2 &= 8^2 \\ a^2 &= 64 - 9 \\ a &= \sqrt{55} \end{aligned}$$

$$\begin{aligned} \sin \alpha &= \frac{\sqrt{55}}{8}, & \csc \alpha &= \frac{8}{\sqrt{55}}, \text{ or } \frac{8\sqrt{55}}{55}, \\ \cos \alpha &= \frac{3}{8}, & \sec \alpha &= \frac{8}{3}, \\ \tan \alpha &= \frac{\sqrt{55}}{3}, & \cot \alpha &= \frac{3}{\sqrt{55}}, \text{ or } \frac{3\sqrt{55}}{55} \end{aligned}$$

Given that $\sin \beta = \frac{5}{13}$, $\cos \beta = \frac{12}{13}$, and $\tan \beta = \frac{5}{12}$, find $\csc \beta$, $\sec \beta$, and $\cot \beta$.

$$\csc \beta = \frac{13}{5}, \quad \sec \beta = \frac{13}{12}, \quad \cot \beta = \frac{12}{5}$$

Find the exact function value.

$$\begin{aligned} \csc 45^\circ &= \frac{2}{\sqrt{2}}, \text{ or } \sqrt{2}, & \tan 60^\circ &= \sqrt{3}, \\ \sin 30^\circ &= \frac{1}{2}, & \cot 45^\circ &= 1, \\ \cos 60^\circ &= \frac{1}{2}, & \sec 30^\circ &= \frac{2}{\sqrt{3}}, \text{ or } \frac{2\sqrt{3}}{3}, \\ \cot 30^\circ &= \frac{3}{\sqrt{3}}, \text{ or } \sqrt{3}, & \sin 60^\circ &= \frac{\sqrt{3}}{2}, \\ \tan 45^\circ &= 1, & \sec 45^\circ &= \frac{2}{\sqrt{2}}, \text{ or } \sqrt{2}, \\ \csc 60^\circ &= \frac{2}{\sqrt{3}}, \text{ or } \frac{2\sqrt{3}}{3}, & \cos 45^\circ &= \frac{\sqrt{2}}{2} \end{aligned}$$

Most calculators can convert D°M'S" notation to decimal degree notation and vice versa. Procedures among calculators vary. We also can convert without using a calculator.

Convert $17^\circ 42' 35''$ to decimal degree notation, rounding the answer to the nearest hundredth of a degree.

$$\begin{aligned} 17^\circ 42' 35'' &= 17^\circ + 42' + \frac{35''}{60} \approx 17^\circ + 42.5833' \\ &\approx 17^\circ + \frac{42.5833^\circ}{60} \approx 17.71^\circ \end{aligned}$$

Convert 23.12° to D°M'S" notation.

$$\begin{aligned} 23.12^\circ &= 23^\circ + 0.12 \times 1^\circ = 23^\circ + 0.12 \times 60' \\ &= 23^\circ + 7.2' = 23^\circ + 7' + 0.2 \times 1' \\ &= 23^\circ + 7' + 0.2 \times 60'' = 23^\circ + 7' + 12'' \\ &= 23^\circ 7' 12'' \end{aligned}$$

Cofunction Identities

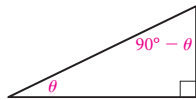

$$\begin{aligned} \sin \theta &= \cos (90^\circ - \theta), & \cos \theta &= \sin (90^\circ - \theta), \\ \tan \theta &= \cot (90^\circ - \theta), & \cot \theta &= \tan (90^\circ - \theta), \\ \sec \theta &= \csc (90^\circ - \theta), & \csc \theta &= \sec (90^\circ - \theta) \end{aligned}$$

Given that $\sin 47^\circ \approx 0.7314$, $\cos 47^\circ \approx 0.6820$, and $\tan 47^\circ \approx 1.0724$, find the six trigonometric function values for 43° .

$$\begin{aligned} \csc 47^\circ &= \frac{1}{\sin 47^\circ} \approx 1.3672, \\ \sec 47^\circ &= \frac{1}{\cos 47^\circ} \approx 1.4663, \\ \cot 47^\circ &= \frac{1}{\tan 47^\circ} \approx 0.9325, \end{aligned}$$

$$\begin{aligned} \sin 43^\circ &= \cos 47^\circ \approx 0.6820, \\ \cos 43^\circ &= \sin 47^\circ \approx 0.7314, \\ \tan 43^\circ &= \cot 47^\circ \approx 0.9325, \\ \csc 43^\circ &= \sec 47^\circ \approx 1.4663, \\ \sec 43^\circ &= \csc 47^\circ \approx 1.3672, \\ \cot 43^\circ &= \tan 47^\circ \approx 1.0724 \end{aligned}$$

SECTION 6.2: APPLICATIONS OF RIGHT TRIANGLES

Solving a Triangle

To **solve** a triangle means to find the lengths of *all* sides and the measures of *all* angles.

Solve this right triangle.

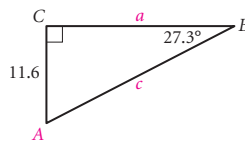

$$\begin{aligned} A &= ?, & a &= ?, \\ B &= 27.3^\circ, & b &= 11.6, \\ C &= 90^\circ, & c &= ? \end{aligned}$$

First, find A:

$$\begin{aligned} A + 27.3^\circ + 90^\circ &= 180^\circ \\ A &= 62.7^\circ. \end{aligned}$$

Then use the tangent and the cosine functions to find a and c :

$$\begin{aligned} \tan 62.7^\circ &= \frac{a}{11.6} & \cos 62.7^\circ &= \frac{11.6}{c} \\ 11.6 \tan 62.7^\circ &= a & c &= \frac{11.6}{\cos 62.7^\circ} \\ 22.5 &\approx a, & c &\approx 25.3. \end{aligned}$$

SECTION 6.3: TRIGONOMETRIC FUNCTIONS OF ANY ANGLE

Coterminal Angles

If two or more angles have the same terminal side, the angles are said to be **coterminal**.

To find angles coterminal with a given angle, we add or subtract multiples of 360° .

Find two positive angles and two negative angles that are coterminal with 123° .

$$\begin{aligned} 123^\circ + 360^\circ &= 483^\circ, \\ 123^\circ + 3(360^\circ) &= 1203^\circ, \\ 123^\circ - 360^\circ &= -237^\circ, \\ 123^\circ - 2(360^\circ) &= -597^\circ \end{aligned}$$

The angles 483° , 1203° , -237° , and -597° are coterminal with 123° .

Complementary and Supplementary Angles

Two acute angles are **complementary** if their sum is 90° .

Two positive angles are **supplementary** if their sum is 180° .

Find the complement and the supplement of 83.5° .

$$\begin{aligned} 90^\circ - 83.5^\circ &= 6.5^\circ, \\ 180^\circ - 83.5^\circ &= 96.5^\circ \end{aligned}$$

The complement of 83.5° is 6.5° , and the supplement of 83.5° is 96.5° .

Trigonometric Functions of Any Angle θ

If $P(x, y)$ is any point on the terminal side of any angle θ in standard position, and r is the distance from the origin to $P(x, y)$,

where $r = \sqrt{x^2 + y^2}$, then

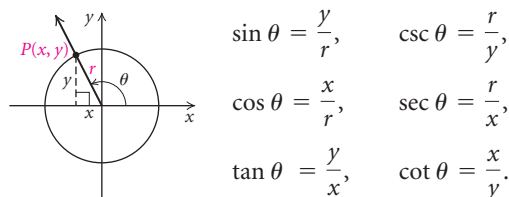

The trigonometric function values of θ depend only on the angle, not on the choice of the point on the terminal side that is used to compute them.

Find the six trigonometric function values for the angle shown.

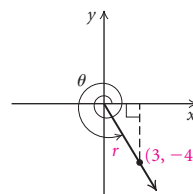

We first determine r :

$$r = \sqrt{x^2 + y^2} = \sqrt{3^2 + (-4)^2} = \sqrt{25} = 5.$$

$$\begin{aligned} \sin \theta &= -\frac{4}{5}, & \csc \theta &= -\frac{5}{4}, \\ \cos \theta &= \frac{3}{5}, & \sec \theta &= \frac{5}{3}, \\ \tan \theta &= -\frac{4}{3}, & \cot \theta &= -\frac{3}{4} \end{aligned}$$

Signs of Function Values

The signs of the function values depend only on the coordinates of the point P on the terminal side of an angle.

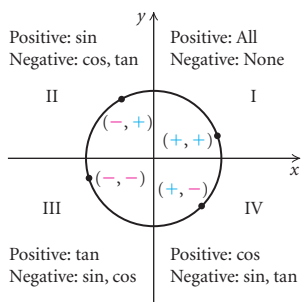

Given that $\cos \alpha = -\frac{1}{5}$ and α is in the third quadrant, find the other function values.

One leg of the reference triangle has length 1, and the length of the hypotenuse is 5. The length of the other leg is $\sqrt{5^2 - 1^2}$, or $2\sqrt{6}$.

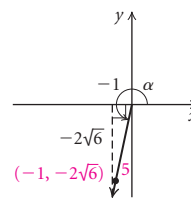

$$\begin{aligned} \sin \alpha &= -\frac{2\sqrt{6}}{5}, & \csc \alpha &= -\frac{5}{2\sqrt{6}}, & \text{or} & -\frac{5\sqrt{6}}{12}, \\ \cos \alpha &= -\frac{1}{5}, & \sec \alpha &= -5, \\ \tan \alpha &= 2\sqrt{6}, & \cot \alpha &= \frac{1}{2\sqrt{6}}, & \text{or} & \frac{\sqrt{6}}{12} \end{aligned}$$

Trigonometric Function Values of Quadrantal Angles

An angle whose terminal side falls on one of the axes is a **quadrantal angle**.

	0° 360°	90°	180°	270°
sin	0	1	0	-1
cos	1	0	-1	0
tan	0	Not defined	0	Not defined

Reference Angles

The **reference angle** for an angle is the acute angle formed by the terminal side of the angle and the x -axis.

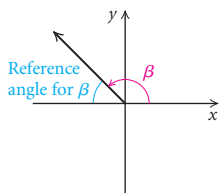

When the reference angle is 30° , 45° , or 60° , we can mentally determine trigonometric function values.

Trigonometric Function Values of Any Angle

Using a calculator, we can approximate the trigonometric function values of any angle.

Find the exact function value.

$$\begin{aligned}\tan(-90^\circ) & \text{ is not defined,} \\ \sin 450^\circ & = 1, \\ \csc 270^\circ & = -1, \\ \cos 720^\circ & = 1, \\ \sec(-180^\circ) & = -1, \\ \cot(-360^\circ) & = 0\end{aligned}$$

Find the sine, cosine, and tangent values for 240° .

The reference angle is $240^\circ - 180^\circ$, or 60° . Thus, $\sin 60^\circ = \frac{\sqrt{3}}{2}$,
 $\cos 60^\circ = \frac{1}{2}$, and $\tan 60^\circ = \sqrt{3}$.

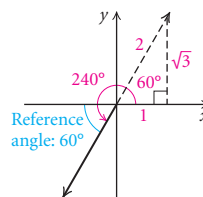

In the third quadrant, the sine and cosine functions are negative, and the tangent function is positive. Thus,

$$\sin 240^\circ = -\frac{\sqrt{3}}{2}, \quad \cos 240^\circ = -\frac{1}{2}, \quad \text{and} \quad \tan 240^\circ = \sqrt{3}.$$

Find each of the following function values using a calculator set in DEGREE mode. Round the values to four decimal places, where appropriate.

$$\begin{aligned}\csc 285^\circ & \approx -1.0353, \\ \sin 25^\circ 14' 38'' & \approx 0.4265, \\ \tan(-1020^\circ) & \approx 1.7321, \\ \cos 51^\circ & \approx 0.6293, \\ \sec(-45^\circ) & \approx 1.4142, \\ \sin 810^\circ & = 1\end{aligned}$$

Given $\cos \theta \approx -0.9724$, $180^\circ < \theta < 270^\circ$, find θ .

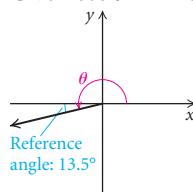

Using a calculator shows that the acute angle whose cosine is 0.9724 is approximately 13.5° . We then find angle θ :

$$180^\circ + 13.5^\circ = 193.5^\circ.$$

Thus, $\theta \approx 193.5^\circ$.

Aerial Navigation

In aerial navigation, directions are given in degrees clockwise from *north*. For example, a direction, or bearing, of 195° is shown below.

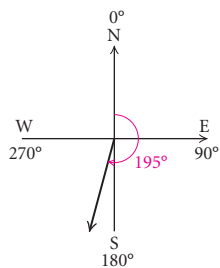

An airplane flies 320 mi from an airport in a direction of 305° . How far north of the airport is the plane then? How far west?

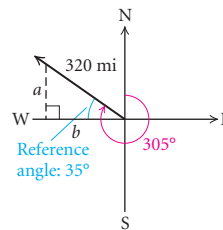

The distance north of the airport a and the distance west of the airport b are parts of a right triangle. The reference angle is $305^\circ - 270^\circ = 35^\circ$. Thus,

$$\begin{aligned} \frac{a}{320} &= \sin 35^\circ \\ a &= 320 \sin 35^\circ \approx 184; \\ \frac{b}{320} &= \cos 35^\circ \\ b &= 320 \cos 35^\circ \approx 262. \end{aligned}$$

The airplane is about 184 mi north and about 262 mi west of the airport.

SECTION 6.4: RADIANs, ARC LENGTH, AND ANGULAR SPEED

The Unit Circle

A circle centered at the origin with a radius of length 1 is called a **unit circle**. Its equation is $x^2 + y^2 = 1$.

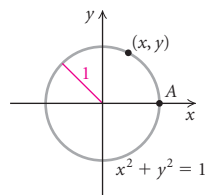

The circumference of circle of radius r is $2\pi r$. For a unit circle, where $r = 1$, the circumference is 2π . If a point starts at A and travels around the circle, it travels a distance of 2π .

Find two real numbers between -2π and 2π that determine each of the labeled points.

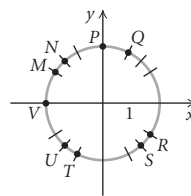

- M: $\frac{5\pi}{6}, -\frac{7\pi}{6}$
- N: $\frac{3\pi}{4}, -\frac{5\pi}{4}$
- P: $\frac{\pi}{2}, -\frac{3\pi}{2}$
- Q: $\frac{\pi}{3}, -\frac{5\pi}{3}$
- R: $\frac{11\pi}{6}, -\frac{\pi}{6}$
- S: $\frac{7\pi}{4}, -\frac{\pi}{4}$
- T: $\frac{4\pi}{3}, -\frac{2\pi}{3}$
- U: $\frac{5\pi}{4}, -\frac{3\pi}{4}$
- V: $\pi, -\pi$

Radian Measure

Consider the unit circle ($r = 1$) and arc length 1. If a ray is drawn from the origin through T , an angle of 1 radian is formed. One radian is approximately 57.3° .

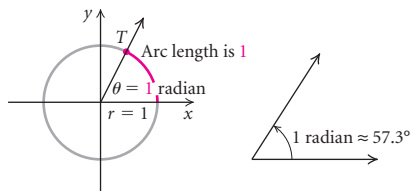

A complete counterclockwise revolution is an angle whose measure is 2π radians, or about 6.28 radians. Thus a rotation of 360° (1 revolution) has a measure of 2π radians.

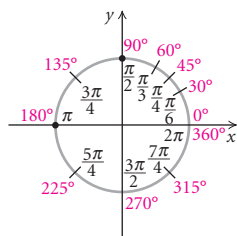
Radian-Degree Equivalents**Converting Between Degree Measure and Radian Measure**

To convert from degree measure to radian measure, multiply by $\frac{\pi \text{ radians}}{180^\circ}$.

To convert from radian measure to degree measure, multiply by $\frac{180^\circ}{\pi \text{ radians}}$.

If no unit is given for a rotation, the rotation is understood to be in radians.

Convert 150° and -63.5° to radian measure. Leave answers in terms of π .

$$150^\circ = 150^\circ \cdot \frac{\pi \text{ radians}}{180^\circ} = \frac{150^\circ}{180^\circ} \pi \text{ radians} = \frac{5\pi}{6};$$

$$-63.5^\circ = -63.5^\circ \cdot \frac{\pi \text{ radians}}{180^\circ} = -\frac{63.5^\circ}{180^\circ} \pi \text{ radians} \approx -0.35\pi$$

Convert -328° and 29.2° to radian measure. Round the answers to two decimal places.

$$-328^\circ = -328^\circ \cdot \frac{\pi \text{ radians}}{180^\circ} = -\frac{328^\circ}{180^\circ} \pi \text{ radians} \approx -5.72;$$

$$29.2^\circ = 29.2^\circ \cdot \frac{\pi \text{ radians}}{180^\circ} = \frac{29.2^\circ}{180^\circ} \pi \text{ radians} \approx 0.51$$

Convert $-\frac{2\pi}{3}$, 5π , and -1.3 to degree measure.

Round the answers to two decimal places.

$$-\frac{2\pi}{3} = -\frac{2\pi}{3} \cdot \frac{180^\circ}{\pi \text{ radians}} = -\frac{2}{3} \cdot 180^\circ = -120^\circ;$$

$$5\pi = 5\pi \cdot \frac{180^\circ}{\pi \text{ radians}} = 5 \cdot 180^\circ = 900^\circ;$$

$$-1.3 = -1.3 \cdot \frac{180^\circ}{\pi \text{ radians}} = \frac{-1.3(180^\circ)}{\pi} \approx -74.48^\circ$$

Find a positive angle and a negative angle that are coterminal with $\frac{7\pi}{4}$.

$$\frac{7\pi}{4} + 2\pi = \frac{7\pi}{4} + \frac{8\pi}{4} = \frac{15\pi}{4};$$

$$\frac{7\pi}{4} - 3(2\pi) = \frac{7\pi}{4} - 6\pi = \frac{7\pi}{4} - \frac{24\pi}{4} = -\frac{17\pi}{4}$$

Two angles coterminal with $\frac{7\pi}{4}$ are $\frac{15\pi}{4}$ and $-\frac{17\pi}{4}$.

Find the complement and the supplement of $\frac{\pi}{8}$.

$$\frac{\pi}{2} - \frac{\pi}{8} = \frac{4\pi}{8} - \frac{\pi}{8} = \frac{3\pi}{8}; \quad 90^\circ = \frac{\pi}{2}$$

$$\pi - \frac{\pi}{8} = \frac{8\pi}{8} - \frac{\pi}{8} = \frac{7\pi}{8}; \quad 180^\circ = \pi$$

The complement of $\frac{\pi}{8}$ is $\frac{3\pi}{8}$, and the supplement of $\frac{\pi}{8}$ is $\frac{7\pi}{8}$.

Radian Measure

The **radian measure** θ of a rotation is the ratio of the distance s traveled by a point at a radius r from the center of rotation to the length of the radius r :

$$\theta = \frac{s}{r}.$$

When the formula $\theta = s/r$ is used, θ must be in radians and s and r must be expressed in the same unit.

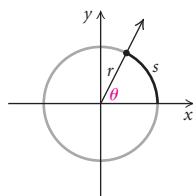

Find the measure of a rotation in radians when a point 6 cm from the center of rotation travels 13 cm.

$$\theta = \frac{s}{r} = \frac{13 \text{ cm}}{6 \text{ cm}} = \frac{13}{6} \text{ radians}$$

Find the length of an arc of a circle of radius 10 yd associated with an angle of $5\pi/4$ radians.

$$\theta = \frac{s}{r}, \quad \text{or} \quad s = r\theta;$$

$$s = r\theta = 10 \text{ yd} \cdot \frac{5\pi}{4} \approx 39.3 \text{ yd}$$

Linear Speed and Angular Speed

Linear speed v is the distance s traveled per unit of time t :

$$v = \frac{s}{t}.$$

Angular speed ω is the amount of rotation θ per unit of time t :

$$\omega = \frac{\theta}{t}.$$

Linear Speed in Terms of Angular Speed

The linear speed v of a point a distance r from the center of rotation is given by

$$v = r\omega,$$

where ω is the angular speed, in radians, per unit of time. The unit of distance for v and r must be the same, ω must be in radians per unit of time, and v and ω must be expressed in the same unit of time.

A wheel with a 40-cm radius is rotating at a rate of 2.5 radians/sec. What is the linear speed of a point on its rim, in meters per minute?

$$r = 40 \text{ cm} \cdot \frac{1 \text{ m}}{100 \text{ cm}} = 0.4 \text{ m};$$

$$\omega = \frac{2.5 \text{ radians}}{1 \text{ sec}} \cdot \frac{60 \text{ sec}}{1 \text{ min}} = \frac{150 \text{ radians}}{1 \text{ min}};$$

$$v = r\omega = 0.4 \text{ m} \cdot \frac{150}{1 \text{ min}} = \frac{60 \text{ m}}{\text{min}}$$

SECTION 6.5: CIRCULAR FUNCTIONS: GRAPHS AND PROPERTIES
Domains of the Trigonometric Functions

In Sections 6.1 and 6.3, the domains of the trigonometric functions were defined as a set of angles or rotations measured in a real number of degree units. In Section 6.4, the domains were considered to be sets of real numbers, or radians. Radian measure for θ is defined as $\theta = s/r$. When $r = 1$, $\theta = s$. The arc length s on the unit circle is the same as the radian measure of the angle θ .

The point $\left(\frac{3}{5}, \frac{4}{5}\right)$ is on the unit circle. Find the coordinates of its reflection across (a) the x -axis, (b) the y -axis, and (c) the origin.

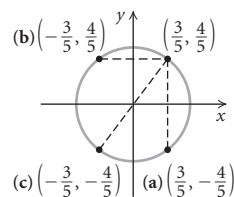

Basic Circular Functions

On the unit circle, s can be considered the radian measure of an angle or the measure of an arc length on the unit circle. In either case, it is a real number. Trigonometric functions with domains composed of real numbers are called **circular functions**.

For a real number s that determines a point (x, y) on the unit circle:

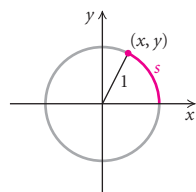

$$\begin{aligned}\sin s &= y, \\ \cos s &= x, \\ \tan s &= \frac{y}{x}, x \neq 0, \\ \csc s &= \frac{1}{y}, y \neq 0, \\ \sec s &= \frac{1}{x}, x \neq 0, \\ \cot s &= \frac{x}{y}, y \neq 0.\end{aligned}$$

Reflections

Because a unit circle is symmetric with respect to the x -axis, the y -axis, and the origin, the coordinates of one point on the unit circle can be used to find coordinates of its reflections.

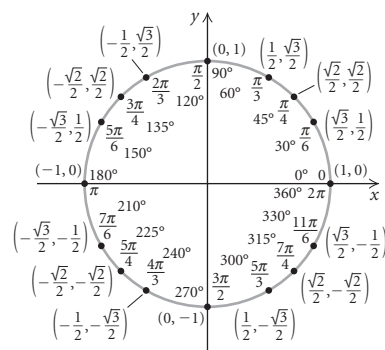
**Periodic Function**

A function f is said to be **periodic** if there exists a positive constant p such that

$$f(s + p) = f(s)$$

for all s in the domain of f . The smallest such positive number p is called the **period** of the function.

Find each function value using coordinates of a point on the unit circle.

$$\begin{aligned}\sin(-5\pi) &= 0, & \csc \frac{\pi}{3} &= \frac{2}{\sqrt{3}}, \text{ or } \frac{2\sqrt{3}}{3}, \\ \cos\left(-\frac{3\pi}{4}\right) &= -\frac{\sqrt{2}}{2}, & \sec \frac{\pi}{6} &= \frac{2}{\sqrt{3}}, \text{ or } \frac{2\sqrt{3}}{3}, \\ \tan \frac{5\pi}{2} &\text{ is not defined,} & \cot \frac{23\pi}{6} &= -\sqrt{3}, \\ \cos\left(-\frac{5\pi}{6}\right) &= -\frac{\sqrt{3}}{2}, & \tan \frac{7\pi}{4} &= -1\end{aligned}$$

Find each function value using a calculator set in RADIAN mode. Round the answers to four decimal places, where appropriate.

$$\begin{aligned}\cos(-14.7) &\approx -0.5336, & \tan \frac{3\pi}{2} &\text{ is not defined,} \\ \sin \frac{9\pi}{5} &\approx -0.5878, & \sec 214 &\approx 1.0733\end{aligned}$$

Graph the sine, cosine, and tangent functions. For graphs of the cosecant, secant, and cotangent functions, see pp. 547–548.

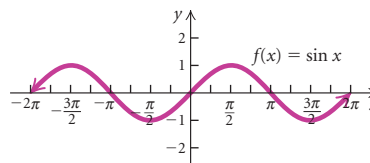

(Continued)

Amplitude

The **amplitude** of a periodic function is defined as one half of the distance between its maximum and minimum function values. It is always positive.

Sine Function

1. Continuous
2. Period: 2π
3. Domain: All real numbers
4. Range: $[-1, 1]$
5. Amplitude: 1
6. Odd: $\sin(-s) = -\sin s$

Cosine Function

1. Continuous
2. Period: 2π
3. Domain: All real numbers
4. Range: $[-1, 1]$
5. Amplitude: 1
6. Even: $\cos(-s) = \cos s$

Tangent Function

1. Period: π
2. Domain: All real numbers except $(\pi/2) + k\pi$, where k is an integer
3. Range: All real numbers

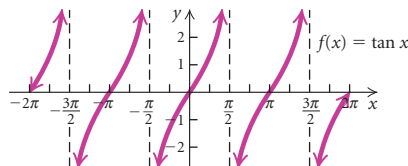
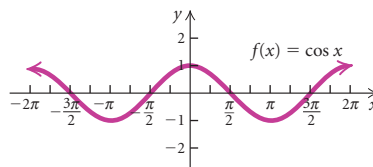

Compare the domains of the sine, cosine, and tangent functions.

FUNCTION	DOMAIN
sine	All real numbers
cosine	All real numbers
tangent	All real numbers except $\pi/2 + k\pi$, where k is an integer

Compare the ranges of the sine, cosine, and tangent functions.

FUNCTION	RANGE
sine	$[-1, 1]$
cosine	$[-1, 1]$
tangent	All real numbers

Compare the periods of the six trigonometric functions.

FUNCTION	PERIOD
sine, cosine, cosecant, secant	2π
tangent, cotangent	π

SECTION 6.6: GRAPHS OF TRANSFORMED SINE AND COSINE FUNCTIONS

Transformations of the Sine Function and the Cosine Function

To graph $y = A \sin(Bx - C) + D$ and $y = A \cos(Bx - C) + D$:

1. Stretch or shrink the graph horizontally according to B . Reflect across the y -axis if $B < 0$. (Period = $|\frac{2\pi}{B}|$)

Determine the amplitude, the period, and the phase shift of

$$y = -\frac{1}{2} \sin\left(2x - \frac{\pi}{2}\right) + 1$$

and sketch the graph of the function.

Amplitude: $\left|-\frac{1}{2}\right| = \frac{1}{2}$

Period: $\left|\frac{2\pi}{2}\right| = \pi$

Phase shift: $\frac{\pi/2}{2} = \frac{\pi}{4}$

(Continued)

- Stretch or shrink the graph vertically according to A . Reflect across the x -axis if $A < 0$. (Amplitude = $|A|$)
- Translate the graph horizontally according to C/B . (Phase shift = $\frac{C}{B}$)
- Translate the graph vertically according to D .

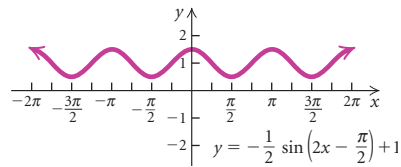

REVIEW EXERCISES

Determine whether the statement is true or false.

- Given that $(-a, b)$ is a point on the unit circle and θ is in the second quadrant, then $\cos \theta$ is a . [6.4]
- Given that $(-c, -d)$ is a point on the unit circle and θ is in the second quadrant, then $\tan \theta = -\frac{c}{d}$. [6.4]
- The measure 300° is greater than the measure 5 radians. [6.4]
- If $\sec \theta > 0$ and $\cot \theta < 0$, then θ is in the fourth quadrant. [6.3]
- The amplitude of $y = \frac{1}{2} \sin x$ is twice as large as the amplitude of $y = \sin \frac{1}{2}x$. [6.6]
- The supplement of $\frac{9}{13}\pi$ is greater than the complement of $\frac{\pi}{6}$. [6.4]
- Find the six trigonometric function values of θ . [6.1]

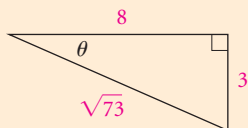

- Given that β is acute and $\beta = \frac{\sqrt{91}}{10}$, find the other five trigonometric function values. [6.1]

Find the exact function value, if it exists.

- $\cos 45^\circ$ [6.1]
- $\cot 60^\circ$ [6.1]
- $\cos 495^\circ$ [6.3]
- $\sin 150^\circ$ [6.3]
- $\sec(-270^\circ)$ [6.3]
- $\tan(-600^\circ)$ [6.3]
- $\csc 60^\circ$ [6.1]
- $\cot(-45^\circ)$ [6.3]
- Convert 22.27° to degrees, minutes, and seconds. Round the answer to the nearest second. [6.1]
- Convert $47^\circ 33' 27''$ to decimal degree notation. Round the answer to two decimal places. [6.1]

Find the function value. Round the answer to four decimal places. [6.3]

- $\tan 2184^\circ$
- $\sec 27.9^\circ$
- $\cos 18^\circ 13' 42''$
- $\sin 245^\circ 24'$
- $\cot(-33.2^\circ)$
- $\sin 556.13^\circ$

Find θ in the interval indicated. Round the answer to the nearest tenth of a degree. [6.3]

- $\cos \theta = -0.9041$, $(180^\circ, 270^\circ)$
- $\tan \theta = 1.0799$, $(0^\circ, 90^\circ)$

Find the exact acute angle θ , in degrees, given the function value. [6.1]

- $\sin \theta = \frac{\sqrt{3}}{2}$
- $\tan \theta = \sqrt{3}$
- $\cos \theta = \frac{\sqrt{2}}{2}$
- $\sec \theta = \frac{2\sqrt{3}}{3}$

31. Given that $\sin 59.1^\circ \approx 0.8581$, $\cos 59.1^\circ \approx 0.5135$, and $\tan 59.1^\circ \approx 1.6709$, find the six function values for 30.9° . [6.1]

Solve each of the following right triangles. Standard lettering has been used. [6.2]

32. $a = 7.3$, $c = 8.6$

33. $a = 30.5$, $B = 51.17^\circ$

34. One leg of a right triangle bears east. The hypotenuse is 734 m long and bears N57°23'E. Find the perimeter of the triangle.

35. An observer's eye is 6 ft above the floor. A mural is being viewed. The bottom of the mural is at floor level. The observer looks down 13° to see the bottom and up 17° to see the top. How tall is the mural?

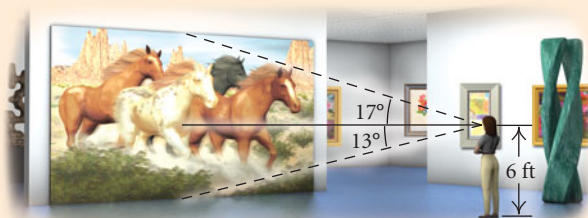

For angles of the following measures, state in which quadrant the terminal side lies. [6.3]

36. $142^\circ 11' 5''$ 37. -635.2° 38. -392°

Find a positive angle and a negative angle that are coterminal with the given angle. Answers may vary.

39. 65° [6.3] 40. $\frac{7\pi}{3}$ [6.4]

Find the complement and the supplement.

41. 13.4° [6.3] 42. $\frac{\pi}{6}$ [6.4]

43. Find the six trigonometric function values for the angle θ shown. [6.3]

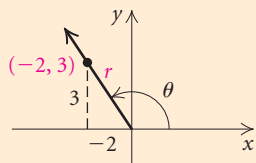

44. Given that $\tan \theta = 2/\sqrt{5}$ and that the terminal side is in quadrant III, find the other five function values. [6.3]

45. An airplane travels at 530 mph for $3\frac{1}{2}$ hr in a direction of 160° from Minneapolis, Minnesota. At the end of that time, how far south of Minneapolis is the airplane? [6.3]

46. On a unit circle, mark and label the points determined by $7\pi/6$, $-3\pi/4$, $-\pi/3$, and $9\pi/4$. [6.4]

For angles of the following measures, convert to radian measure in terms of π , and convert to radian measure not in terms of π . Round the answer to two decimal places. [6.4]

47. 145.2° 48. -30°

Convert to degree measure. Round the answer to two decimal places. [6.4]

49. $\frac{3\pi}{2}$ 50. 3
51. -4.5 52. 11π

53. Find the length of an arc of a circle, given a central angle of $\pi/4$ and a radius of 7 cm. [6.4]

54. An arc 18 m long on a circle of radius 8 m subtends an angle of how many radians? how many degrees, to the nearest degree? [6.4]

55. A waterwheel in a watermill has a radius of 7 ft and makes a complete revolution in 70 sec. What is the linear speed, in feet per minute, of a point on the rim? [6.4]



56. An automobile wheel has a diameter of 14 in. If the car travels at a speed of 55 mph, what is the angular velocity, in radians per hour, of a point on the edge of the wheel? [6.4]

57. The point $(\frac{3}{5}, -\frac{4}{5})$ is on a unit circle. Find the coordinates of its reflections across the x -axis, the y -axis, and the origin. [6.5]

Find the exact function value, if it exists. [6.5]

58. $\cos \pi$ 59. $\tan \frac{5\pi}{4}$
 60. $\sin \frac{5\pi}{3}$ 61. $\sin\left(-\frac{7\pi}{6}\right)$
 62. $\tan \frac{\pi}{6}$ 63. $\cos(-13\pi)$

Find the function value. Round the answer to four decimal places. [6.5]

64. $\sin 24$ 65. $\cos(-75)$
 66. $\cot 16\pi$ 67. $\tan \frac{3\pi}{7}$
 68. $\sec 14.3$ 69. $\cos\left(-\frac{\pi}{5}\right)$

70. Graph each of the six trigonometric functions from -2π to 2π . [6.5]
 71. What is the period of each of the six trigonometric functions? [6.5]
 72. Complete the following table. [6.5]

Function	Domain	Range
sine		
cosine		
tangent		

73. Complete the following table with the sign of the specified trigonometric function value in each of the four quadrants. [6.3]

Function	I	II	III	IV
sine				
cosine				
tangent				

Determine the amplitude, the period, and the phase shift of the function, and sketch the graph of the function. [6.6]

74. $y = \sin\left(x + \frac{\pi}{2}\right)$
 75. $y = 3 + \frac{1}{2}\cos\left(2x - \frac{\pi}{2}\right)$

In Exercises 76–79, match the function with one of the graphs (a)–(d), which follow. [6.6]

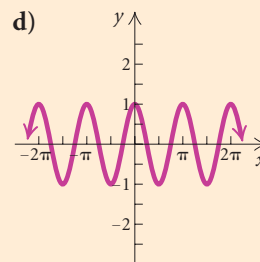
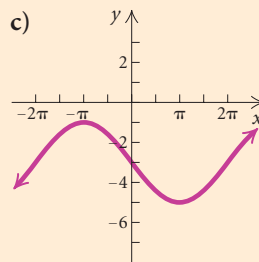
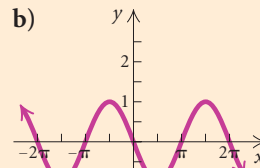
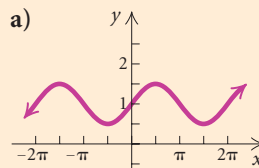

76. $y = \cos 2x$ 77. $y = \frac{1}{2}\sin x + 1$
 78. $y = -2\sin \frac{1}{2}x - 3$ 79. $y = -\cos\left(x - \frac{\pi}{2}\right)$
 80. Sketch a graph of $y = 3\cos x + \sin x$ for values of x between 0 and 2π . [6.6]
 81. Graph: $f(x) = e^{-0.7x}\cos x$. [6.6]
 82. Which of the following is the reflection of $\left(-\frac{1}{2}, \frac{\sqrt{3}}{2}\right)$ across the y -axis? [6.5]
 A. $\left(\frac{1}{2}, -\frac{\sqrt{3}}{2}\right)$ B. $\left(\frac{\sqrt{3}}{2}, \frac{1}{2}\right)$
 C. $\left(\frac{1}{2}, \frac{\sqrt{3}}{2}\right)$ D. $\left(\frac{\sqrt{3}}{2}, -\frac{1}{2}\right)$
 83. Which of the following is the domain of the cosine function? [6.5]
 A. $(-1, 1)$ B. $(-\infty, \infty)$
 C. $[0, \infty)$ D. $[-1, 1]$

84. The graph of $f(x) = -\cos(-x)$ is which of the following? [6.6]

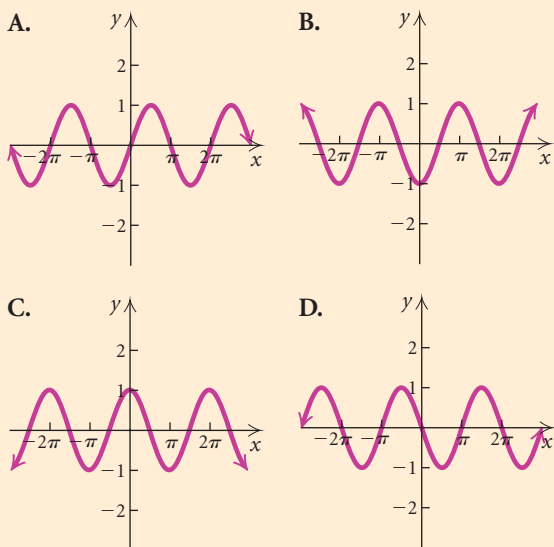

Synthesis

85. Graph $y = 3 \sin(x/2)$, and determine the domain, the range, and the period. [6.6]
86. In the graph below, $y_1 = \sin x$ is shown and y_2 is shown in red. Express y_2 as a transformation of the graph of y_1 . [6.6]

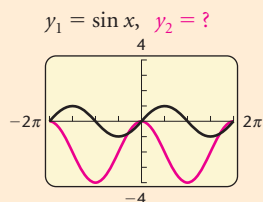

87. Find the domain of $y = \log(\cos x)$. [6.6]
88. Given that $\sin x = 0.6144$ and that the terminal side is in quadrant II, find the other basic circular function values. [6.3]

Collaborative Discussion and Writing

89. Compare the terms radian and degree. [6.1], [6.4]
90. In circular motion with a fixed angular speed, the length of the radius is directly proportional to the linear speed. Explain why with an example. [6.4]
91. Explain why both the sine function and the cosine function are continuous, but the tangent function, defined as sine/cosine, is not continuous. [6.5]
92. In the transformation steps listed in Section 6.6, why must step (1) precede step (3)? Give an example that illustrates this. [6.6]
93. In the equations $y = A \sin(Bx - C) + D$ and $y = A \cos(Bx - C) + D$, which constants translate the graphs and which constants stretch and shrink the graphs? Describe in your own words the effect of each constant. [6.6]
94. Two new cars are each driven at an average speed of 60 mph for an extended highway test drive of 2000 mi. The diameters of the wheels of the two cars are 15 in. and 16 in., respectively. If the cars use tires of equal durability and profile, differing only by the diameter, which car will probably need new tires first? Explain your answer. [6.4]

Chapter 6 Test

1. Find the six trigonometric function values of θ .

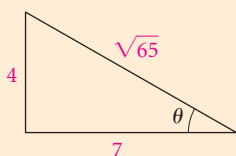

Find the exact function value, if it exists.

2. $\sin 120^\circ$
3. $\tan(-45^\circ)$
4. $\cos 3\pi$
5. $\sec \frac{5\pi}{4}$
6. Convert $38^\circ 27' 56''$ to decimal degree notation. Round the answer to two decimal places.

Find the function values. Round the answers to four decimal places.

7. $\tan 526.4^\circ$
 8. $\sin(-12^\circ)$
 9. $\sec \frac{5\pi}{9}$
 10. $\cos 76.07$
 11. Find the exact acute angle θ , in degrees, for which $\sin \theta = \frac{1}{2}$.
 12. Given that $\sin 28.4^\circ \approx 0.4756$, $\cos 28.4^\circ \approx 0.8796$, and $\tan 28.4^\circ \approx 0.5407$, find the six trigonometric function values for 61.6° .
 13. Solve the right triangle with $b = 45.1$ and $A = 35.9^\circ$. Standard lettering has been used.
 14. Find a positive angle and a negative angle coterminal with a 112° angle.
 15. Find the supplement of $\frac{5\pi}{6}$.
 16. Given that $\sin \theta = -4/\sqrt{41}$ and that the terminal side is in quadrant IV, find the other five trigonometric function values.
 17. Convert 210° to radian measure in terms of π .
 18. Convert $\frac{3\pi}{4}$ to degree measure.
 19. Find the length of an arc of a circle given a central angle of $\pi/3$ and a radius of 16 cm.
- Consider the function $y = -\sin(x - \pi/2) + 1$ for Exercises 20–23.

20. Find the amplitude.
21. Find the period.
22. Find the phase shift.
23. Which is the graph of the function?

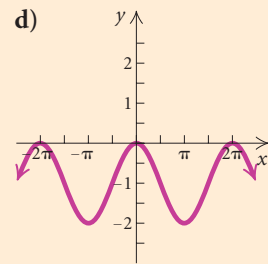
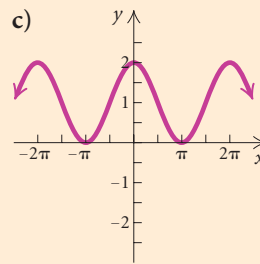
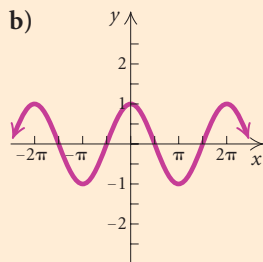
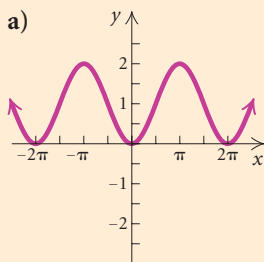

24. **Angle of Elevation.** The longest escalator in the world is in the subway system in St. Petersburg, Russia. The escalator is 330.7 m long and rises a vertical distance of 59.7 m. What is its angle of elevation?
25. **Location.** A pickup-truck camper travels at 50 mph for 6 hr in a direction of 115° from Buffalo, Wyoming. At the end of that time, how far east of Buffalo is the camper?
26. **Linear Speed.** A ferris wheel has a radius of 6 m and revolves at 1.5 rpm. What is the linear speed, in meters per minute?
27. Graph: $f(x) = \frac{1}{2}x^2 \sin x$.
28. The graph of $f(x) = -\sin(-x)$ is which of the following?

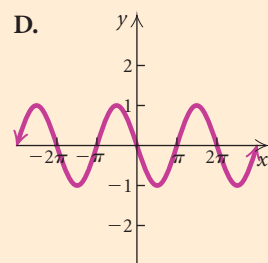
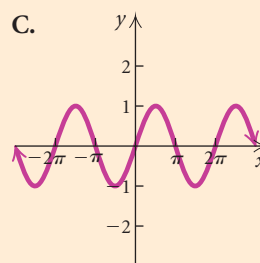
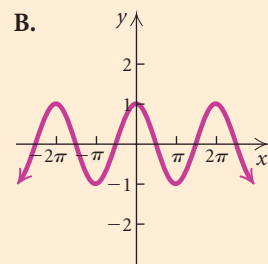
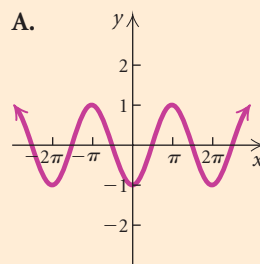

Synthesis

29. Determine the domain of $f(x) = \frac{-3}{\sqrt{\cos x}}$.

Trigonometric Identities, Inverse Functions, and Equations

CHAPTER

7



Application

The number of daylight hours in Kajaani, Finland, varies from approximately 4.3 hr on December 21 to 20.7 on June 11. The following sine function can be used to approximate the number of daylight hours, y , in Kajaani for day x :

$$y = 7.8787 \sin(0.0166x - 1.2723) + 12.1840.$$

- Approximate the number of daylight hours in Kajaani for April 5 ($x = 95$), for August 18 ($x = 230$), and for November 29 ($x = 333$).
- Determine on which days of the year there will be about 12 hr of daylight.

This problem appears as Exercise 45 in Section 7.5.

- Identities: Pythagorean and Sum and Difference
 - Identities: Cofunction, Double-Angle, and Half-Angle
 - Proving Trigonometric Identities
- Mid-Chapter Mixed Review
- Inverses of the Trigonometric Functions
 - Solving Trigonometric Equations

Visualizing the Graph

Study Guide

Review Exercises

Chapter Test

Identities: Pythagorean and Sum and Difference

7.1

- ▶ State the Pythagorean identities.
- ▶ Simplify and manipulate expressions containing trigonometric expressions.
- ▶ Use the sum and difference identities to find function values.

An **identity** is an equation that is true for all *possible* replacements of the variables. The following is a list of the identities studied in Chapter 6.

Basic Identities

$$\begin{array}{lll} \sin x = \frac{1}{\csc x}, & \csc x = \frac{1}{\sin x}, & \sin(-x) = -\sin x, \\ \cos x = \frac{1}{\sec x}, & \sec x = \frac{1}{\cos x}, & \cos(-x) = \cos x, \\ \tan x = \frac{1}{\cot x}, & \cot x = \frac{1}{\tan x}, & \tan(-x) = -\tan x, \\ & & \tan x = \frac{\sin x}{\cos x}, \\ & & \cot x = \frac{\cos x}{\sin x} \end{array}$$

In this section, we will develop some other important identities.

▶ Pythagorean Identities

We now consider three other identities that are fundamental to a study of trigonometry. They are called the *Pythagorean identities*. Recall that the equation of a unit circle in the xy -plane is

$$x^2 + y^2 = 1.$$

For any point on the unit circle, the coordinates x and y satisfy this equation. Suppose that a real number s determines a point on the unit circle with coordinates (x, y) , or $(\cos s, \sin s)$. Then $x = \cos s$ and $y = \sin s$. Substituting $\cos s$ for x and $\sin s$ for y in the equation of the unit circle gives us the identity

$$(\cos s)^2 + (\sin s)^2 = 1, \quad \text{Substituting } \cos s \text{ for } x \text{ and } \sin s \text{ for } y$$

which can be expressed as

$$\sin^2 s + \cos^2 s = 1.$$

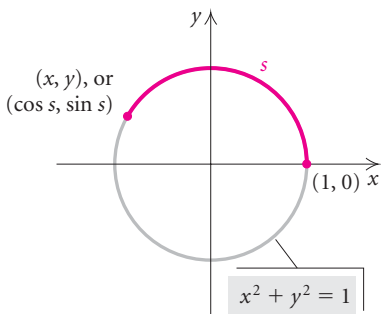

It is conventional in trigonometry to use the notation $\sin^2 s$ rather than $(\sin s)^2$. Note that $\sin^2 s \neq \sin s^2$.

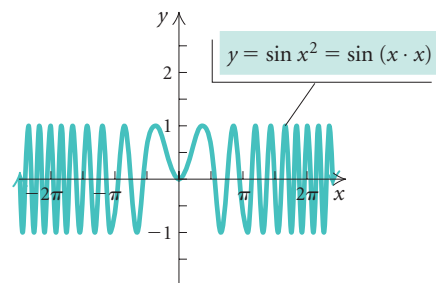
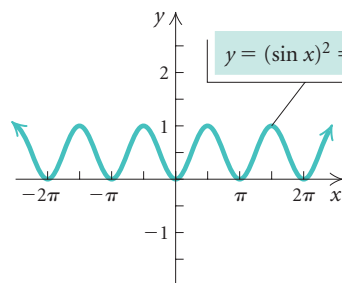

The identity $\sin^2 s + \cos^2 s = 1$ gives a relationship between the sine and the cosine of any real number s . It is an important **Pythagorean identity**.

We can divide by $\sin^2 s$ on both sides of the preceding identity:

$$\frac{\sin^2 s}{\sin^2 s} + \frac{\cos^2 s}{\sin^2 s} = \frac{1}{\sin^2 s}. \quad \text{Dividing by } \sin^2 s$$

Simplifying gives us a second Pythagorean identity:

$$1 + \cot^2 s = \csc^2 s.$$

This equation is true for any replacement of s with a real number for which $\sin^2 s \neq 0$, since we divided by $\sin^2 s$. But the numbers for which $\sin^2 s = 0$ (or $\sin s = 0$) are exactly the ones for which the cotangent function and the cosecant function are not defined. Hence our new equation holds for all real numbers s for which $\cot s$ and $\csc s$ are defined and is thus an identity.

The third Pythagorean identity is obtained by dividing by $\cos^2 s$ on both sides of the first Pythagorean identity:

$$\frac{\sin^2 s}{\cos^2 s} + \frac{\cos^2 s}{\cos^2 s} = \frac{1}{\cos^2 s} \quad \text{Dividing by } \cos^2 s$$

$$\tan^2 s + 1 = \sec^2 s. \quad \text{Simplifying}$$

The identities we have developed hold no matter what symbols are used for the variables. For example, we could write $\sin^2 s + \cos^2 s = 1$, $\sin^2 \theta + \cos^2 \theta = 1$, or $\sin^2 x + \cos^2 x = 1$.

Pythagorean Identities

$$\sin^2 x + \cos^2 x = 1,$$

$$1 + \cot^2 x = \csc^2 x,$$

$$1 + \tan^2 x = \sec^2 x$$

It is often helpful to express the Pythagorean identities in equivalent forms.

Pythagorean Identities	Equivalent Forms
$\sin^2 x + \cos^2 x = 1$	$\sin^2 x = 1 - \cos^2 x$ $\cos^2 x = 1 - \sin^2 x$
$1 + \cot^2 x = \csc^2 x$	$1 = \csc^2 x - \cot^2 x$ $\cot^2 x = \csc^2 x - 1$
$1 + \tan^2 x = \sec^2 x$	$1 = \sec^2 x - \tan^2 x$ $\tan^2 x = \sec^2 x - 1$

► Simplifying Trigonometric Expressions

We can factor, simplify, and manipulate trigonometric expressions in the same way that we manipulate strictly algebraic expressions.

■ STUDY TIP

The examples in each section were chosen to prepare you for the exercise set. Study the step-by-step annotated solutions of the examples, noting that substitutions are highlighted in red. The time you spend understanding the examples will save you valuable time when you do your assignment.

EXAMPLE 1 Multiply and simplify: $\cos x (\tan x - \sec x)$.

Solution

$$\cos x (\tan x - \sec x)$$

$$= \cos x \tan x - \cos x \sec x$$

$$= \cos x \frac{\sin x}{\cos x} - \cos x \frac{1}{\cos x}$$

$$= \sin x - 1$$

Multiplying

Recalling the identities $\tan x = \frac{\sin x}{\cos x}$

and $\sec x = \frac{1}{\cos x}$ and substituting

Simplifying

➔ **Now Try Exercise 3.**

There is no general procedure for simplifying trigonometric expressions, but it is often helpful to write everything in terms of sines and cosines, as we did in Example 1. We also look for a Pythagorean identity within a trigonometric expression.

EXAMPLE 2 Factor and simplify: $\sin^2 x \cos^2 x + \cos^4 x$.

Solution

$$\sin^2 x \cos^2 x + \cos^4 x$$

$$= \cos^2 x (\sin^2 x + \cos^2 x)$$

$$= \cos^2 x \cdot (1)$$

$$= \cos^2 x$$

Removing a common factor

Using $\sin^2 x + \cos^2 x = 1$

➔ **Now Try Exercise 9.**

TECHNOLOGY CONNECTION

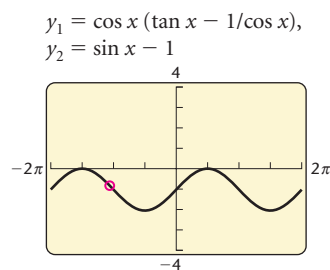

X	Y1	Y2
-6.283	-1	-1
-5.498	-.2929	-.2929
-4.712	ERROR	0
-3.927	-.2929	-.2929
-3.142	-1	-1
-2.356	-1.707	-1.707
-1.571	ERROR	-2

X = -6.28318530718

TblStart = -2π

Δ Tbl = $\pi/4$

A graphing calculator can be used to perform a partial check of an identity. First, we graph the expression on the left side of the equals sign. Then we graph the expression on the right side using the same screen. If the two graphs are indistinguishable, then we have a partial verification that the equation is an identity. Of course, we can never see the entire graph, so there can always be some doubt. Also, the graphs may not overlap precisely, but you may not be able to tell because the difference between the graphs may be less than the width of a pixel. However, if the graphs are obviously different, we know that a mistake has been made.

Consider the identity in Example 1:

$$\cos x (\tan x - \sec x) = \sin x - 1.$$

Recalling that $\sec x = 1/\cos x$, we enter

$$y_1 = \cos x (\tan x - 1/\cos x) \quad \text{and} \quad y_2 = \sin x - 1.$$

To graph, we first select SEQUENTIAL mode. Then we select the “line”-graph style for y_1 and the “path”-graph style, denoted by \circ , for y_2 . The calculator will graph y_1 first. Then it will graph y_2 as the circular cursor traces the leading edge of the graph, allowing us to determine whether the graphs coincide. As you can see in the graph screen at left, the graphs appear to be identical. Thus, $\cos x (\tan x - \sec x) = \sin x - 1$ is most likely an identity.

The TABLE feature can also be used to check identities. Note in the table at left that the function values are the same except for those values of x for which $\cos x = 0$. The domain of y_1 excludes these values. The domain of y_2 is the set of all real numbers. Thus all real numbers except $\pm\pi/2$, $\pm3\pi/2$, $\pm5\pi/2, \dots$ are possible replacements for x in the identity. Recall that an identity is an equation that is true for all *possible* replacements.

EXAMPLE 3 Simplify each of the following trigonometric expressions.

a) $\frac{\cot(-\theta)}{\csc(-\theta)}$

b) $\frac{2 \sin^2 t + \sin t - 3}{1 - \cos^2 t - \sin t}$

Solution

$$\begin{aligned}
 \text{a) } \frac{\cot(-\theta)}{\csc(-\theta)} &= \frac{\frac{\cos(-\theta)}{\sin(-\theta)}}{\frac{1}{\sin(-\theta)}} \\
 &= \frac{\cos(-\theta)}{\sin(-\theta)} \cdot \sin(-\theta) \\
 &= \cos(-\theta) \\
 &= \cos \theta
 \end{aligned}$$

Rewriting in terms of sines and cosines

Multiplying by the reciprocal, $\sin(-\theta)/1$

Removing a factor of 1, $\sin(-\theta)/\sin(-\theta)$

The cosine function is even.

FACTORING
REVIEW SECTION R.4

$$\begin{aligned}
 \text{b) } & \frac{2 \sin^2 t + \sin t - 3}{1 - \cos^2 t - \sin t} \\
 &= \frac{2 \sin^2 t + \sin t - 3}{\sin^2 t - \sin t} && \text{Substituting } \sin^2 t \text{ for } 1 - \cos^2 t \\
 &= \frac{(2 \sin t + 3)(\cancel{\sin t - 1})}{\sin t (\cancel{\sin t - 1})} && \text{Factoring in both the numerator and the denominator} \\
 &= \frac{2 \sin t + 3}{\sin t} && \text{Simplifying} \\
 &= \frac{2 \sin t}{\sin t} + \frac{3}{\sin t} \\
 &= 2 + \frac{3}{\sin t}, \text{ or } 2 + 3 \csc t
 \end{aligned}$$

 **Now Try Exercises 17 and 19.**

We can add and subtract trigonometric rational expressions in the same way that we do algebraic expressions, writing expressions with a common denominator before adding and subtracting numerators.

EXAMPLE 4 Add and simplify: $\frac{\cos x}{1 + \sin x} + \tan x$.

Solution

RATIONAL EXPRESSIONS
REVIEW SECTION R.6

$$\begin{aligned}
 \frac{\cos x}{1 + \sin x} + \tan x &= \frac{\cos x}{1 + \sin x} + \frac{\sin x}{\cos x} && \text{Using } \tan x = \frac{\sin x}{\cos x} \\
 &= \frac{\cos x}{1 + \sin x} \cdot \frac{\cos x}{\cos x} + \frac{\sin x}{\cos x} \cdot \frac{1 + \sin x}{1 + \sin x} && \text{Multiplying by forms of 1} \\
 &= \frac{\cos^2 x + \sin x + \sin^2 x}{\cos x (1 + \sin x)} && \text{Adding} \\
 &= \frac{1 + \sin x}{\cos x (1 + \sin x)} && \text{Using } \sin^2 x + \cos^2 x = 1 \\
 &= \frac{1}{\cos x}, \text{ or } \sec x && \text{Simplifying}
 \end{aligned}$$

 **Now Try Exercise 27.**

When radicals occur, the use of absolute value is sometimes necessary, but it can be difficult to determine when to use it. In Examples 5 and 6, we will assume that all radicands are nonnegative. This means that the identities are meant to be confined to certain quadrants.

EXAMPLE 5 Multiply and simplify: $\sqrt{\sin^3 x \cos x} \cdot \sqrt{\cos x}$.

Solution

$$\begin{aligned}
 \sqrt{\sin^3 x \cos x} \cdot \sqrt{\cos x} &= \sqrt{\sin^3 x \cos^2 x} = \sqrt{\sin^2 x \cos^2 x \sin x} \\
 &= \sin x \cos x \sqrt{\sin x}
 \end{aligned}$$

 **Now Try Exercise 31.**

EXAMPLE 6 Rationalize the denominator: $\sqrt{\frac{2}{\tan x}}$.

Solution

$$\begin{aligned}\sqrt{\frac{2}{\tan x}} &= \sqrt{\frac{2}{\tan x} \cdot \frac{\tan x}{\tan x}} \\ &= \sqrt{\frac{2 \tan x}{\tan^2 x}} \\ &= \frac{\sqrt{2 \tan x}}{\tan x}\end{aligned}$$

➔ **Now Try Exercise 37.**

Often in calculus, a substitution is a useful manipulation, as we show in the following example.

EXAMPLE 7 Express $\sqrt{9 + x^2}$ as a trigonometric function of θ without using radicals by letting $x = 3 \tan \theta$. Assume that $0 < \theta < \pi/2$. Then find $\sin \theta$ and $\cos \theta$.

Solution We have

$$\begin{aligned}\sqrt{9 + x^2} &= \sqrt{9 + (3 \tan \theta)^2} \\ &= \sqrt{9 + 9 \tan^2 \theta} \\ &= \sqrt{9(1 + \tan^2 \theta)} \\ &= \sqrt{9 \sec^2 \theta} \\ &= 3|\sec \theta| = 3 \sec \theta.\end{aligned}$$

Substituting $3 \tan \theta$ for x

Factoring

Using $1 + \tan^2 x = \sec^2 x$

For $0 < \theta < \pi/2$, $\sec \theta > 0$, so $|\sec \theta| = \sec \theta$.

We can express $\sqrt{9 + x^2} = 3 \sec \theta$ as

$$\sec \theta = \frac{\sqrt{9 + x^2}}{3}.$$

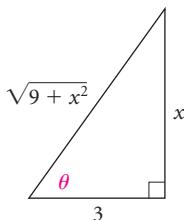

In a right triangle, we know that $\sec \theta$ is hypotenuse/adjacent, when θ is one of the acute angles. Using the Pythagorean theorem, we can determine that the side opposite θ is x . Then from the right triangle, we see that

$$\sin \theta = \frac{x}{\sqrt{9 + x^2}} \quad \text{and} \quad \cos \theta = \frac{3}{\sqrt{9 + x^2}}.$$

➔ **Now Try Exercise 45.**

► Sum and Difference Identities

We now develop some important identities involving sums or differences of two numbers (or angles), beginning with an identity for the cosine of the difference of two numbers. We use the letters u and v for these numbers.

Let's consider a real number u in the interval $[\pi/2, \pi]$ and a real number v in the interval $[0, \pi/2]$. These determine points A and B on the unit circle, as shown below. The arc length s is $u - v$, and we know that $0 \leq s \leq \pi$. Recall that the coordinates of A are $(\cos u, \sin u)$, and the coordinates of B are $(\cos v, \sin v)$.

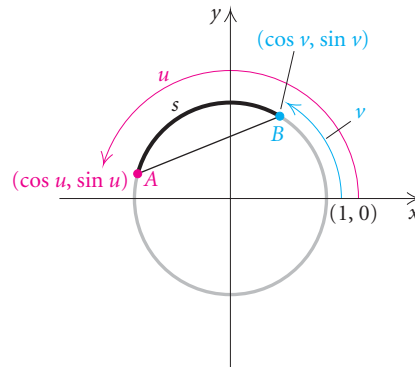

DISTANCE FORMULA

REVIEW SECTION 1.1

Using the distance formula, we can write an expression for the distance AB :

$$AB = \sqrt{(\cos u - \cos v)^2 + (\sin u - \sin v)^2}.$$

This can be simplified as follows:

$$\begin{aligned} AB &= \sqrt{\cos^2 u - 2 \cos u \cos v + \cos^2 v + \sin^2 u - 2 \sin u \sin v + \sin^2 v} \\ &= \sqrt{(\sin^2 u + \cos^2 u) + (\sin^2 v + \cos^2 v) - 2(\cos u \cos v + \sin u \sin v)} \\ &= \sqrt{2 - 2(\cos u \cos v + \sin u \sin v)}. \end{aligned}$$

Now let's imagine rotating the circle so that point B is at $(1, 0)$, as shown at left. Although the coordinates of point A are now $(\cos s, \sin s)$, the distance AB has not changed.

Again we use the distance formula to write an expression for the distance AB :

$$AB = \sqrt{(\cos s - 1)^2 + (\sin s - 0)^2}.$$

This can be simplified as follows:

$$\begin{aligned} AB &= \sqrt{\cos^2 s - 2 \cos s + 1 + \sin^2 s} \\ &= \sqrt{(\sin^2 s + \cos^2 s) + 1 - 2 \cos s} \\ &= \sqrt{2 - 2 \cos s}. \end{aligned}$$

Equating our two expressions for AB , we obtain

$$\sqrt{2 - 2(\cos u \cos v + \sin u \sin v)} = \sqrt{2 - 2 \cos s}.$$

Solving this equation for $\cos s$ gives

$$\cos s = \cos u \cos v + \sin u \sin v. \quad (1)$$

But $s = u - v$, so we have the equation

$$\cos(u - v) = \cos u \cos v + \sin u \sin v. \quad (2)$$

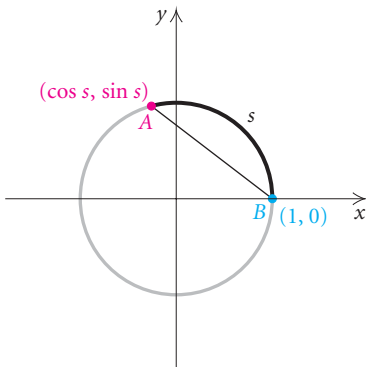

Formula (1) above holds when s is the length of the shortest arc from A to B . Given any real numbers u and v , the length of the shortest arc from A to B is not always $u - v$. In fact, it could be $v - u$. However, since $\cos(-x) = \cos x$, we know that $\cos(v - u) = \cos(u - v)$. Thus, $\cos s$ is always equal to $\cos(u - v)$. Formula (2) holds for all real numbers u and v . That formula is thus the identity we sought:

$$\cos(u - v) = \cos u \cos v + \sin u \sin v.$$

The cosine sum formula follows easily from the one we have just derived. Let's consider $\cos(u + v)$. This is equal to $\cos[u - (-v)]$, and by the identity above, we have

$$\begin{aligned}\cos(u + v) &= \cos[u - (-v)] \\ &= \cos u \cos(-v) + \sin u \sin(-v).\end{aligned}$$

But $\cos(-v) = \cos v$ and $\sin(-v) = -\sin v$, so the identity we seek is the following:

$$\cos(u + v) = \cos u \cos v - \sin u \sin v.$$

EXAMPLE 8 Find $\cos(5\pi/12)$ exactly.

Solution We can express $5\pi/12$ as a difference of two numbers whose exact sine and cosine values are known:

$$\frac{5\pi}{12} = \frac{9\pi}{12} - \frac{4\pi}{12}, \quad \text{or} \quad \frac{3\pi}{4} - \frac{\pi}{3}.$$

Then, using $\cos(u - v) = \cos u \cos v + \sin u \sin v$, we have

$$\begin{aligned}\cos \frac{5\pi}{12} &= \cos\left(\frac{3\pi}{4} - \frac{\pi}{3}\right) = \cos \frac{3\pi}{4} \cos \frac{\pi}{3} + \sin \frac{3\pi}{4} \sin \frac{\pi}{3} \\ &= -\frac{\sqrt{2}}{2} \cdot \frac{1}{2} + \frac{\sqrt{2}}{2} \cdot \frac{\sqrt{3}}{2} \\ &= -\frac{\sqrt{2}}{4} + \frac{\sqrt{6}}{4} \\ &= \frac{\sqrt{6} - \sqrt{2}}{4}.\end{aligned}$$

 **Now Try Exercise 55.**

Consider $\cos(\pi/2 - \theta)$. We can use the identity for the cosine of a difference to simplify as follows:

$$\begin{aligned}\cos\left(\frac{\pi}{2} - \theta\right) &= \cos \frac{\pi}{2} \cos \theta + \sin \frac{\pi}{2} \sin \theta \\ &= 0 \cdot \cos \theta + 1 \cdot \sin \theta \\ &= \sin \theta.\end{aligned}$$

Thus we have developed the identity

$$\sin \theta = \cos\left(\frac{\pi}{2} - \theta\right). \quad \text{This cofunction identity first appeared in Section 6.1.} \quad (3)$$

TECHNOLOGY CONNECTION

We can check using a graphing calculator set in RADIAN mode.

$\cos(5\pi/12)$.2588190451
$(\sqrt{6}-\sqrt{2})/4$.2588190451

This identity holds for any real number θ . From it we can obtain an identity for the cosine function. We first let α be any real number. Then we replace θ in $\sin \theta = \cos(\pi/2 - \theta)$ with $\pi/2 - \alpha$. This gives us

$$\sin\left(\frac{\pi}{2} - \alpha\right) = \cos\left[\frac{\pi}{2} - \left(\frac{\pi}{2} - \alpha\right)\right] = \cos \alpha,$$

which yields the identity

$$\cos \alpha = \sin\left(\frac{\pi}{2} - \alpha\right). \quad (4)$$

Using identities (3) and (4) and the identity for the cosine of a difference, we can obtain an identity for the sine of a sum. We start with identity (3) and substitute $u + v$ for θ :

$$\sin \theta = \cos\left(\frac{\pi}{2} - \theta\right) \quad \text{Identity (3)}$$

$$\sin(u + v) = \cos\left[\frac{\pi}{2} - (u + v)\right] \quad \text{Substituting } u + v \text{ for } \theta$$

$$= \cos\left[\left(\frac{\pi}{2} - u\right) - v\right]$$

$$= \cos\left(\frac{\pi}{2} - u\right) \cos v + \sin\left(\frac{\pi}{2} - u\right) \sin v$$

Using the identity for the cosine of a difference

$$= \sin u \cos v + \cos u \sin v. \quad \text{Using identities (3) and (4)}$$

Thus the identity we seek is

$$\sin(u + v) = \sin u \cos v + \cos u \sin v.$$

To find a formula for the sine of a difference, we can use the identity just derived, substituting $-v$ for v :

$$\sin(u + (-v)) = \sin u \cos(-v) + \cos u \sin(-v).$$

Simplifying gives us

$$\sin(u - v) = \sin u \cos v - \cos u \sin v.$$

EXAMPLE 9 Find $\sin 105^\circ$ exactly.

Solution We express 105° as the sum of two measures:

$$105^\circ = 45^\circ + 60^\circ.$$

Then

$$\sin 105^\circ = \sin(45^\circ + 60^\circ)$$

$$= \sin 45^\circ \cos 60^\circ + \cos 45^\circ \sin 60^\circ$$

Using $\sin(u + v) = \sin u \cos v + \cos u \sin v$

$$= \frac{\sqrt{2}}{2} \cdot \frac{1}{2} + \frac{\sqrt{2}}{2} \cdot \frac{\sqrt{3}}{2}$$

$$= \frac{\sqrt{2} + \sqrt{6}}{4}.$$

 Now Try Exercise 51.

Formulas for the tangent of a sum or a difference can be derived using identities already established. A summary of the sum and difference identities follows.

Sum and Difference Identities

$$\sin(u \pm v) = \sin u \cos v \pm \cos u \sin v,$$

$$\cos(u \pm v) = \cos u \cos v \mp \sin u \sin v,$$

$$\tan(u \pm v) = \frac{\tan u \pm \tan v}{1 \mp \tan u \tan v}$$

There are six identities here, half of them obtained by using the signs shown in color.

EXAMPLE 10 Find $\tan 15^\circ$ exactly.

Solution We rewrite 15° as $45^\circ - 30^\circ$ and use the identity for the tangent of a difference:

$$\begin{aligned} \tan 15^\circ &= \tan(45^\circ - 30^\circ) \\ &= \frac{\tan 45^\circ - \tan 30^\circ}{1 + \tan 45^\circ \tan 30^\circ} \\ &= \frac{1 - \sqrt{3}/3}{1 + 1 \cdot \sqrt{3}/3} = \frac{3 - \sqrt{3}}{3 + \sqrt{3}}. \end{aligned}$$

 **Now Try Exercise 53.**

EXAMPLE 11 Assume that $\sin \alpha = \frac{2}{3}$ and $\sin \beta = \frac{1}{3}$ and that α and β are between 0 and $\pi/2$. Then evaluate $\sin(\alpha + \beta)$.

Solution Using the identity for the sine of a sum, we have

$$\begin{aligned} \sin(\alpha + \beta) &= \sin \alpha \cos \beta + \cos \alpha \sin \beta \\ &= \frac{2}{3} \cos \beta + \frac{1}{3} \cos \alpha. \end{aligned}$$

To finish, we need to know the values of $\cos \beta$ and $\cos \alpha$. Using reference triangles and the Pythagorean theorem, we can determine these values from the diagrams:

$$\cos \alpha = \frac{\sqrt{5}}{3} \quad \text{and} \quad \cos \beta = \frac{2\sqrt{2}}{3}.$$

Cosine values are positive in the first quadrant.

Substituting these values gives us

$$\begin{aligned} \sin(\alpha + \beta) &= \frac{2}{3} \cdot \frac{2\sqrt{2}}{3} + \frac{1}{3} \cdot \frac{\sqrt{5}}{3} \\ &= \frac{4}{9} \sqrt{2} + \frac{1}{9} \sqrt{5}, \quad \text{or} \quad \frac{4\sqrt{2} + \sqrt{5}}{9}. \end{aligned}$$

 **Now Try Exercise 65.**

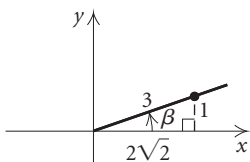
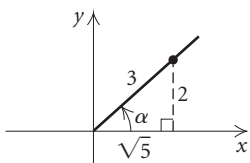

7.1

Exercise Set

Multiply and simplify.

- $(\sin x - \cos x)(\sin x + \cos x)$
- $\tan x (\cos x - \csc x)$
- $\cos y \sin y (\sec y + \csc y)$
- $(\sin x + \cos x)(\sec x + \csc x)$
- $(\sin \phi - \cos \phi)^2$
- $(1 + \tan x)^2$
- $(\sin x + \csc x)(\sin^2 x + \csc^2 x - 1)$
- $(1 - \sin t)(1 + \sin t)$

Factor and simplify.

- $\sin x \cos x + \cos^2 x$
- $\tan^2 \theta - \cot^2 \theta$
- $\sin^4 x - \cos^4 x$
- $4 \sin^2 y + 8 \sin y + 4$
- $2 \cos^2 x + \cos x - 3$
- $3 \cot^2 \beta + 6 \cot \beta + 3$
- $\sin^3 x + 27$
- $1 - 125 \tan^3 s$

Simplify.

- $\frac{\sin^2 x \cos x}{\cos^2 x \sin x}$
- $\frac{30 \sin^3 x \cos x}{6 \cos^2 x \sin x}$
- $\frac{\sin^2 x + 2 \sin x + 1}{\sin x + 1}$
- $\frac{\cos^2 \alpha - 1}{\cos \alpha + 1}$
- $\frac{4 \tan t \sec t + 2 \sec t}{6 \tan t \sec t + 2 \sec t}$
- $\frac{\csc(-x)}{\cot(-x)}$

$$23. \frac{\sin^4 x - \cos^4 x}{\sin^2 x - \cos^2 x}$$

- $\frac{4 \cos^3 x}{\sin^2 x} \cdot \left(\frac{\sin x}{4 \cos x}\right)^2$
- $\frac{5 \cos \phi}{\sin^2 \phi} \cdot \frac{\sin^2 \phi - \sin \phi \cos \phi}{\sin^2 \phi - \cos^2 \phi}$
- $\frac{\tan^2 y}{\sec y} \div \frac{3 \tan^3 y}{\sec y}$
- $\frac{1}{\sin^2 s - \cos^2 s} - \frac{2}{\cos s - \sin s}$
- $\left(\frac{\sin x}{\cos x}\right)^2 - \frac{1}{\cos^2 x}$
- $\frac{\sin^2 \theta - 9}{2 \cos \theta + 1} \cdot \frac{10 \cos \theta + 5}{3 \sin \theta + 9}$
- $\frac{9 \cos^2 \alpha - 25}{2 \cos \alpha - 2} \cdot \frac{\cos^2 \alpha - 1}{6 \cos \alpha - 10}$

Simplify. Assume that all radicands are nonnegative.

- $\sqrt{\sin^2 x \cos x} \cdot \sqrt{\cos x}$
- $\sqrt{\cos^2 x \sin x} \cdot \sqrt{\sin x}$
- $\sqrt{\cos \alpha \sin^2 \alpha} - \sqrt{\cos^3 \alpha}$
- $\sqrt{\tan^2 x - 2 \tan x \sin x + \sin^2 x}$
- $(1 - \sqrt{\sin y})(\sqrt{\sin y} + 1)$
- $\sqrt{\cos \theta} (\sqrt{2 \cos \theta} + \sqrt{\sin \theta \cos \theta})$

Rationalize the denominator.

- $\sqrt{\frac{\sin x}{\cos x}}$
- $\sqrt{\frac{\cos x}{\tan x}}$
- $\sqrt{\frac{\cos^2 y}{2 \sin^2 y}}$
- $\sqrt{\frac{1 - \cos \beta}{1 + \cos \beta}}$

Rationalize the numerator.

- $\sqrt{\frac{\cos x}{\sin x}}$
- $\sqrt{\frac{\sin x}{\cot x}}$
- $\sqrt{\frac{1 + \sin y}{1 - \sin y}}$
- $\sqrt{\frac{\cos^2 x}{2 \sin^2 x}}$

Use the given substitution to express the given radical expression as a trigonometric function without radicals. Assume that $a > 0$ and $0 < \theta < \pi/2$. Then find expressions for the indicated trigonometric functions.

45. Let $x = a \sin \theta$ in $\sqrt{a^2 - x^2}$. Then find $\cos \theta$ and $\tan \theta$.
46. Let $x = 2 \tan \theta$ in $\sqrt{4 + x^2}$. Then find $\sin \theta$ and $\cos \theta$.
47. Let $x = 3 \sec \theta$ in $\sqrt{x^2 - 9}$. Then find $\sin \theta$ and $\cos \theta$.
48. Let $x = a \sec \theta$ in $\sqrt{x^2 - a^2}$. Then find $\sin \theta$ and $\cos \theta$.

Use the given substitution to express the given radical expression as a trigonometric function without radicals. Assume that $0 < \theta < \pi/2$.

49. Let $x = \sin \theta$ in $\frac{x^2}{\sqrt{1 - x^2}}$.
50. Let $x = 4 \sec \theta$ in $\frac{\sqrt{x^2 - 16}}{x^2}$.

Use the sum and difference identities to evaluate exactly.

51. $\sin \frac{\pi}{12}$ 52. $\cos 75^\circ$
53. $\tan 105^\circ$ 54. $\tan \frac{5\pi}{12}$
55. $\cos 15^\circ$ 56. $\sin \frac{7\pi}{12}$

First write each of the following as a trigonometric function of a single angle. Then evaluate.

57. $\sin 37^\circ \cos 22^\circ + \cos 37^\circ \sin 22^\circ$
58. $\cos 83^\circ \cos 53^\circ + \sin 83^\circ \sin 53^\circ$
59. $\cos 19^\circ \cos 5^\circ - \sin 19^\circ \sin 5^\circ$
60. $\sin 40^\circ \cos 15^\circ - \cos 40^\circ \sin 15^\circ$
61. $\frac{\tan 20^\circ + \tan 32^\circ}{1 - \tan 20^\circ \tan 32^\circ}$
62. $\frac{\tan 35^\circ - \tan 12^\circ}{1 + \tan 35^\circ \tan 12^\circ}$
63. Derive the formula for the tangent of a sum.
64. Derive the formula for the tangent of a difference.

Assuming that $\sin u = \frac{3}{5}$ and $\sin v = \frac{4}{5}$ and that u and v are between 0 and $\pi/2$, evaluate each of the following exactly.

65. $\cos(u + v)$ 66. $\tan(u - v)$
67. $\sin(u - v)$ 68. $\cos(u - v)$

Assuming that $\sin \theta = 0.6249$ and $\cos \phi = 0.1102$ and that both θ and ϕ are first-quadrant angles, evaluate each of the following.

69. $\tan(\theta + \phi)$ 70. $\sin(\theta - \phi)$
71. $\cos(\theta - \phi)$ 72. $\cos(\theta + \phi)$

Simplify.

73. $\sin(\alpha + \beta) + \sin(\alpha - \beta)$
74. $\cos(\alpha + \beta) - \cos(\alpha - \beta)$
75. $\cos(u + v) \cos v + \sin(u + v) \sin v$
76. $\sin(u - v) \cos v + \cos(u - v) \sin v$

Skill Maintenance

Solve.

77. $2x - 3 = 2(x - \frac{3}{2})$
78. $x - 7 = x + 3.4$

Given that $\sin 31^\circ = 0.5150$ and $\cos 31^\circ = 0.8572$, find the specified function value.

79. $\sec 59^\circ$ 80. $\tan 59^\circ$

Synthesis

Angles Between Lines. One of the identities gives an easy way to find an angle formed by two lines. Consider two lines with equations $l_1: y = m_1x + b_1$ and $l_2: y = m_2x + b_2$.

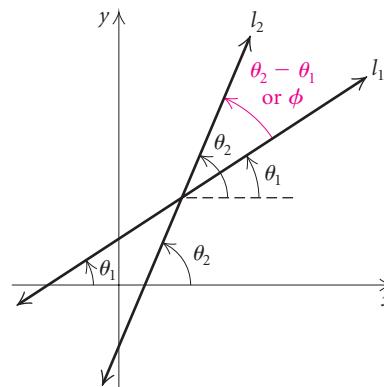

The slopes m_1 and m_2 are the tangents of the angles θ_1 and θ_2 that the lines form with the positive direction of the x -axis. Thus we have $m_1 = \tan \theta_1$ and $m_2 = \tan \theta_2$. To find the measure of $\theta_2 - \theta_1$, or ϕ , we proceed as follows:

$$\begin{aligned}\tan \phi &= \tan (\theta_2 - \theta_1) \\ &= \frac{\tan \theta_2 - \tan \theta_1}{1 + \tan \theta_2 \tan \theta_1} \\ &= \frac{m_2 - m_1}{1 + m_2 m_1}.\end{aligned}$$

This formula also holds when the lines are taken in the reverse order. When ϕ is acute, $\tan \phi$ will be positive. When ϕ is obtuse, $\tan \phi$ will be negative.

Find the measure of the angle from l_1 to l_2 .

81. $l_1: 2x = 3 - 2y,$
 $l_2: x + y = 5$

82. $l_1: 3y = \sqrt{3}x + 3,$
 $l_2: y = \sqrt{3}x + 2$

83. $l_1: y = 3,$
 $l_2: x + y = 5$

84. $l_1: 2x + y - 4 = 0,$
 $l_2: y - 2x + 5 = 0$

85. **Rope Course and Climbing Wall.** For a rope course and climbing wall, a guy wire R is attached 47 ft high on a vertical pole. Another guy wire S is attached 40 ft above the ground on the same pole. (Source: Experiential Resources, Inc., Todd



Domeck, Owner) Find the angle α between the wires if they are attached to the ground 50 ft from the pole.

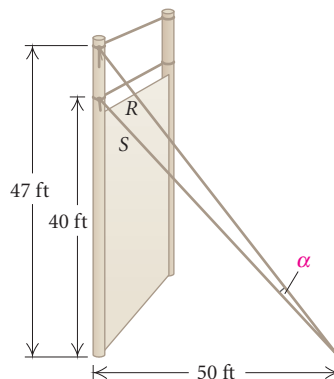

86. **Circus Guy Wire.** In a circus, a guy wire A is attached to the top of a 30-ft pole. Wire B is used for performers to walk up to the tight wire, 10 ft above the ground. Find the angle ϕ between the wires if they are attached to the ground 40 ft from the pole.

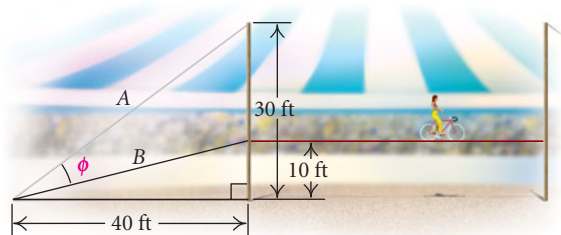

87. Given that $f(x) = \cos x$, show that
$$\frac{f(x+h) - f(x)}{h} = \cos x \left(\frac{\cos h - 1}{h} \right) - \sin x \left(\frac{\sin h}{h} \right).$$
88. Given that $f(x) = \sin x$, show that
$$\frac{f(x+h) - f(x)}{h} = \sin x \left(\frac{\cos h - 1}{h} \right) + \cos x \left(\frac{\sin h}{h} \right).$$

Show that each of the following is not an identity by finding a replacement or replacements for which the sides of the equation do not name the same number.

89. $\frac{\sin 5x}{x} = \sin 5$

90. $\sqrt{\sin^2 \theta} = \sin \theta$

91. $\cos(2\alpha) = 2 \cos \alpha$

92. $\sin(-x) = \sin x$

93. $\frac{\cos 6x}{\cos x} = 6$

94. $\tan^2 \theta + \cot^2 \theta = 1$

Find the slope of line l_1 , where m_2 is the slope of line l_2 and ϕ is the smallest positive angle from l_1 to l_2 .

95. $m_2 = \frac{2}{3}$, $\phi = 30^\circ$
96. $m_2 = \frac{4}{3}$, $\phi = 45^\circ$
97. Line l_1 contains the points $(-3, 7)$ and $(-3, -2)$.
Line l_2 contains $(0, -4)$ and $(2, 6)$. Find the smallest positive angle from l_1 to l_2 .
98. Line l_1 contains the points $(-2, 4)$ and $(5, -1)$.
Find the slope of line l_2 such that the angle from l_1 to l_2 is 45° .
99. Find an identity for $\cos 2\theta$. (Hint: $2\theta = \theta + \theta$.)
100. Find an identity for $\sin 2\theta$. (Hint: $2\theta = \theta + \theta$.)

Derive the identity.

101. $\tan\left(x + \frac{\pi}{4}\right) = \frac{1 + \tan x}{1 - \tan x}$
102. $\sin\left(x - \frac{3\pi}{2}\right) = \cos x$
103. $\sin(\alpha + \beta) + \sin(\alpha - \beta) = 2 \sin \alpha \cos \beta$
104. $\frac{\sin(\alpha + \beta)}{\cos(\alpha - \beta)} = \frac{\tan \alpha + \tan \beta}{1 + \tan \alpha \tan \beta}$

Identities: Cofunction, Double-Angle, and Half-Angle

7.2

- ▶ Use cofunction identities to derive other identities.
- ▶ Use the double-angle identities to find function values of twice an angle when one function value is known for that angle.
- ▶ Use the half-angle identities to find function values of half an angle when one function value is known for that angle.
- ▶ Simplify trigonometric expressions using the double-angle identities and the half-angle identities.

▶ Cofunction Identities

Each of the identities listed below yields a conversion to a *cofunction*. For this reason, we call them cofunction identities.

Cofunction Identities

$$\begin{aligned} \sin\left(\frac{\pi}{2} - x\right) &= \cos x, & \cos\left(\frac{\pi}{2} - x\right) &= \sin x, \\ \tan\left(\frac{\pi}{2} - x\right) &= \cot x, & \cot\left(\frac{\pi}{2} - x\right) &= \tan x, \\ \sec\left(\frac{\pi}{2} - x\right) &= \csc x, & \csc\left(\frac{\pi}{2} - x\right) &= \sec x \end{aligned}$$

We verified the first two of these identities in Section 7.1. The other four can be proved using the first two and the definitions of the trigonometric functions. These identities hold for all real numbers, and thus, for all angle

measures, but if we restrict θ to values such that $0^\circ < \theta < 90^\circ$, or $0 < \theta < \pi/2$, then we have a special application to the acute angles of a right triangle.

Comparing graphs can lead to possible identities. On the left below, we see that the graph of $y = \sin(x + \pi/2)$ is a translation of the graph of $y = \sin x$ to the left $\pi/2$ units. On the right, we see the graph of $y = \cos x$.

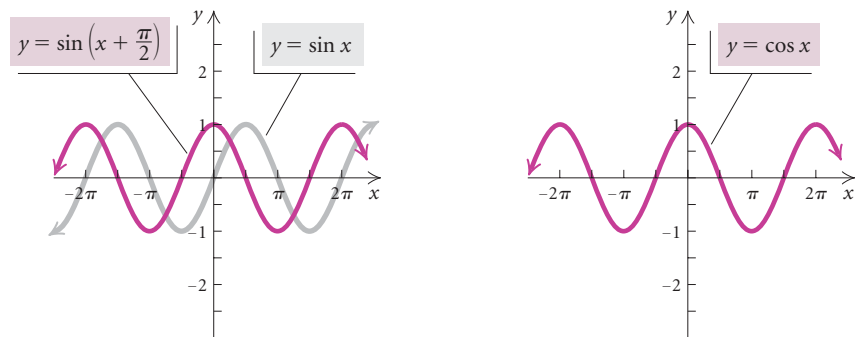

Comparing the graphs, we note a possible identity:

$$\sin\left(x + \frac{\pi}{2}\right) = \cos x.$$

The identity can be proved using the identity for the sine of a sum developed in Section 7.1.

EXAMPLE 1 Prove the identity $\sin(x + \pi/2) = \cos x$.

Solution

$$\begin{aligned} \sin\left(x + \frac{\pi}{2}\right) &= \sin x \cos \frac{\pi}{2} + \cos x \sin \frac{\pi}{2} && \text{Using } \sin(u + v) = \sin u \cos v + \cos u \sin v \\ &= \sin x \cdot 0 + \cos x \cdot 1 \\ &= \cos x \end{aligned}$$



We now state four more cofunction identities. These new identities that involve the sine and cosine functions can be verified using previously established identities as seen in Example 1.

Cofunction Identities for the Sine and the Cosine

$$\sin\left(x \pm \frac{\pi}{2}\right) = \pm \cos x, \quad \cos\left(x \pm \frac{\pi}{2}\right) = \mp \sin x$$

EXAMPLE 2 Find an identity for each of the following.

a) $\tan\left(x + \frac{\pi}{2}\right)$

b) $\sec(x - 90^\circ)$

Solution

a) We have

$$\begin{aligned}\tan\left(x + \frac{\pi}{2}\right) &= \frac{\sin\left(x + \frac{\pi}{2}\right)}{\cos\left(x + \frac{\pi}{2}\right)} \\ &= \frac{\cos x}{-\sin x} \\ &= -\cot x.\end{aligned}$$

Using $\tan x = \frac{\sin x}{\cos x}$

Using cofunction identities

Thus the identity we seek is

$$\tan\left(x + \frac{\pi}{2}\right) = -\cot x.$$

b) We have

$$\sec(x - 90^\circ) = \frac{1}{\cos(x - 90^\circ)} = \frac{1}{\sin x} = \csc x.$$

Thus, $\sec(x - 90^\circ) = \csc x$.

➔ Now Try Exercises 5 and 7.

TECHNOLOGY CONNECTION

Graphing calculators provide visual partial checks of identities. We can graph

$$y_1 = \sin 2x, \quad \text{and}$$

$$y_2 = 2 \sin x \cos x$$

using the “line”-graph style for y_1 and the “path”-graph style for y_2 and see that they appear to have the same graph. We can also use the TABLE feature.

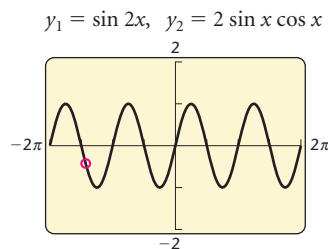

X	Y1	Y2
-6.283	2E-13	0
-5.498	1	1
-4.712	0	0
-3.927	-1	-1
-3.142	0	0
-2.356	1	1
-1.571	0	0

X = -1.57079632679

 $\Delta \text{Tbl} = \pi/4$ **► Double-Angle Identities**

If we double an angle of measure x , the new angle will have measure $2x$. **Double-angle identities** give trigonometric function values of $2x$ in terms of function values of x . To develop these identities, we will use the sum formulas from the preceding section. We first develop a formula for $\sin 2x$. Recall that

$$\sin(u + v) = \sin u \cos v + \cos u \sin v.$$

We will consider a number x and substitute it for both u and v in this identity. Doing so gives us

$$\begin{aligned}\sin(x + x) &= \sin 2x \\ &= \sin x \cos x + \cos x \sin x \\ &= 2 \sin x \cos x.\end{aligned}$$

Our first double-angle identity is thus

$$\sin 2x = 2 \sin x \cos x.$$

Double-angle identities for the cosine and tangent functions can be derived in much the same way as the identity above:

$$\cos 2x = \cos^2 x - \sin^2 x, \quad \tan 2x = \frac{2 \tan x}{1 - \tan^2 x}.$$

EXAMPLE 3 Given that $\tan \theta = -\frac{3}{4}$ and θ is in quadrant II, find each of the following.

- a) $\sin 2\theta$
c) $\tan 2\theta$

- b) $\cos 2\theta$
d) The quadrant in which 2θ lies

Solution By drawing a reference triangle as shown, we find that

$$\sin \theta = \frac{3}{5}$$

and

$$\cos \theta = -\frac{4}{5}.$$

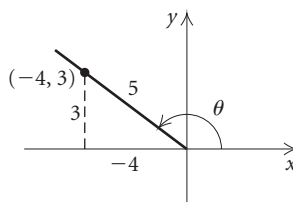

Thus we have the following.

$$\text{a) } \sin 2\theta = 2 \sin \theta \cos \theta = 2 \cdot \frac{3}{5} \cdot \left(-\frac{4}{5}\right) = -\frac{24}{25}$$

$$\text{b) } \cos 2\theta = \cos^2 \theta - \sin^2 \theta = \left(-\frac{4}{5}\right)^2 - \left(\frac{3}{5}\right)^2 = \frac{16}{25} - \frac{9}{25} = \frac{7}{25}$$

$$\text{c) } \tan 2\theta = \frac{2 \tan \theta}{1 - \tan^2 \theta} = \frac{2 \cdot \left(-\frac{3}{4}\right)}{1 - \left(-\frac{3}{4}\right)^2} = \frac{-\frac{3}{2}}{1 - \frac{9}{16}} = -\frac{3}{2} \cdot \frac{16}{7} = -\frac{24}{7}$$

Note that $\tan 2\theta$ could have been found more easily in this case by simply dividing:

$$\tan 2\theta = \frac{\sin 2\theta}{\cos 2\theta} = \frac{-\frac{24}{25}}{\frac{7}{25}} = -\frac{24}{7}.$$

d) Since $\sin 2\theta$ is negative and $\cos 2\theta$ is positive, we know that 2θ is in quadrant IV. **Now Try Exercise 9.**

Two other useful identities for $\cos 2x$ can be derived easily, as follows.

$$\begin{aligned} \cos 2x &= \cos^2 x - \sin^2 x & \cos 2x &= \cos^2 x - \sin^2 x \\ &= (1 - \sin^2 x) - \sin^2 x & &= \cos^2 x - (1 - \cos^2 x) \\ &= 1 - 2\sin^2 x & &= 2\cos^2 x - 1 \end{aligned}$$

Double-Angle Identities

$$\begin{aligned} \sin 2x &= 2 \sin x \cos x & \cos 2x &= \cos^2 x - \sin^2 x \\ \tan 2x &= \frac{2 \tan x}{1 - \tan^2 x} & &= 1 - 2\sin^2 x \\ & & &= 2\cos^2 x - 1 \end{aligned}$$

Solving the last two cosine double-angle identities for $\sin^2 x$ and $\cos^2 x$, respectively, we obtain two more identities:

$$\sin^2 x = \frac{1 - \cos 2x}{2} \quad \text{and} \quad \cos^2 x = \frac{1 + \cos 2x}{2}.$$

Using division and these two identities gives us the following useful identity:

$$\tan^2 x = \frac{1 - \cos 2x}{1 + \cos 2x}.$$

EXAMPLE 4 Find an equivalent expression for each of the following.

- a) $\sin 3\theta$ in terms of function values of θ
 b) $\cos^3 x$ in terms of function values of x or $2x$, raised only to the first power

Solution

$$\begin{aligned} \text{a) } \sin 3\theta &= \sin(2\theta + \theta) \\ &= \sin 2\theta \cos \theta + \cos 2\theta \sin \theta \\ &= (2 \sin \theta \cos \theta) \cos \theta + (2 \cos^2 \theta - 1) \sin \theta \\ &\quad \text{Using } \sin 2\theta = 2 \sin \theta \cos \theta \text{ and } \cos 2\theta = 2 \cos^2 \theta - 1 \\ &= 2 \sin \theta \cos^2 \theta + 2 \sin \theta \cos^2 \theta - \sin \theta \\ &= 4 \sin \theta \cos^2 \theta - \sin \theta \end{aligned}$$

We could also substitute $\cos^2 \theta - \sin^2 \theta$ or $1 - 2 \sin^2 \theta$ for $\cos 2\theta$. Each substitution leads to a different result, but all results are equivalent.

$$\begin{aligned} \text{b) } \cos^3 x &= \cos^2 x \cos x \\ &= \frac{1 + \cos 2x}{2} \cos x \\ &= \frac{\cos x + \cos x \cos 2x}{2} \end{aligned}$$

 **Now Try Exercise 15.**

► Half-Angle Identities

If we take half of an angle of measure x , the new angle will have measure $x/2$. **Half-angle identities** give trigonometric function values of $x/2$ in terms of function values of x . To develop these identities, we replace x with $x/2$ and take square roots. For example,

$$\begin{aligned} \sin^2 x &= \frac{1 - \cos 2x}{2} && \text{Solving the identity} \\ &&& \cos 2x = 1 - 2 \sin^2 x \text{ for } \sin^2 x \\ \sin^2 \frac{x}{2} &= \frac{1 - \cos 2 \cdot \frac{x}{2}}{2} && \text{Substituting } \frac{x}{2} \text{ for } x \\ \sin^2 \frac{x}{2} &= \frac{1 - \cos x}{2} \\ \sin \frac{x}{2} &= \pm \sqrt{\frac{1 - \cos x}{2}} && \text{Taking square roots} \end{aligned}$$

The formula is called a *half-angle formula*. The use of $+$ and $-$ depends on the quadrant in which the angle $x/2$ lies. Half-angle identities for the cosine and tangent functions can be derived in a similar manner. Two additional formulas for the half-angle tangent identity are listed below.

Half-Angle Identities

$$\begin{aligned}\sin \frac{x}{2} &= \pm \sqrt{\frac{1 - \cos x}{2}}, \\ \cos \frac{x}{2} &= \pm \sqrt{\frac{1 + \cos x}{2}}, \\ \tan \frac{x}{2} &= \pm \sqrt{\frac{1 - \cos x}{1 + \cos x}} \\ &= \frac{\sin x}{1 + \cos x} = \frac{1 - \cos x}{\sin x}\end{aligned}$$

EXAMPLE 5 Find $\tan(\pi/8)$ exactly.

Solution We have

$$\begin{aligned}\tan \frac{\pi}{8} &= \tan \frac{\frac{\pi}{4}}{2} = \frac{\sin \frac{\pi}{4}}{1 + \cos \frac{\pi}{4}} = \frac{\frac{\sqrt{2}}{2}}{1 + \frac{\sqrt{2}}{2}} = \frac{\frac{\sqrt{2}}{2}}{2 + \sqrt{2}} \\ &= \frac{\sqrt{2}}{2 + \sqrt{2}} = \frac{\sqrt{2}}{2 + \sqrt{2}} \cdot \frac{2 - \sqrt{2}}{2 - \sqrt{2}} \\ &= \sqrt{2} - 1.\end{aligned}$$

 **Now Try Exercise 21.**

The identities that we have developed are also useful for simplifying trigonometric expressions.

EXAMPLE 6 Simplify each of the following.

a) $\frac{\sin x \cos x}{\frac{1}{2} \cos 2x}$ b) $2 \sin^2 \frac{x}{2} + \cos x$

Solution

a) We can obtain $2 \sin x \cos x$ in the numerator by multiplying the expression by $\frac{2}{2}$:

$$\begin{aligned}\frac{\sin x \cos x}{\frac{1}{2} \cos 2x} &= \frac{2}{2} \cdot \frac{\sin x \cos x}{\frac{1}{2} \cos 2x} = \frac{2 \sin x \cos x}{\cos 2x} \\ &= \frac{\sin 2x}{\cos 2x} && \text{Using } \sin 2x = 2 \sin x \cos x \\ &= \tan 2x.\end{aligned}$$

b) We have

$$\begin{aligned}2 \sin^2 \frac{x}{2} + \cos x &= 2 \left(\frac{1 - \cos x}{2} \right) + \cos x \\ &= 1 - \cos x + \cos x && \text{Using } \sin \frac{x}{2} = \pm \sqrt{\frac{1 - \cos x}{2}}, \text{ or } \sin^2 \frac{x}{2} = \frac{1 - \cos x}{2} \\ &= 1.\end{aligned}$$

 **Now Try Exercise 33.**

TECHNOLOGY CONNECTION

Here we show a partial check of Example 6(b) using a graph and a table.

$$y_1 = 2 \sin^2 \frac{x}{2} + \cos x, \quad y_2 = 1$$

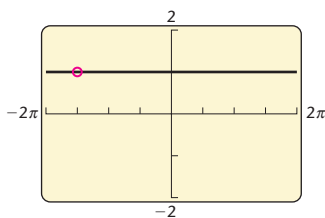

X	Y1	Y2
-6.283	1	1
-5.498	1	1
-4.712	1	1
-3.927	1	1
-3.142	1	1
-2.356	1	1
-1.571	1	1

X = -6.28318530718

$\Delta Tbl = \pi/4$

7.2

Exercise Set

1. Given that $\sin(3\pi/10) \approx 0.8090$ and $\cos(3\pi/10) \approx 0.5878$, find each of the following.

- a) The other four function values for $3\pi/10$
 b) The six function values for $\pi/5$

2. Given that

$$\sin \frac{\pi}{12} = \frac{\sqrt{2 - \sqrt{3}}}{2} \text{ and } \cos \frac{\pi}{12} = \frac{\sqrt{2 + \sqrt{3}}}{2},$$

find exact answers for each of the following.

- a) The other four function values for $\pi/12$
 b) The six function values for $5\pi/12$
3. Given that $\sin \theta = \frac{1}{3}$ and that the terminal side is in quadrant II, find exact answers for each of the following.

- a) The other function values for θ
 b) The six function values for $\pi/2 - \theta$
 c) The six function values for $\theta - \pi/2$

4. Given that $\cos \phi = \frac{4}{5}$ and that the terminal side is in quadrant IV, find exact answers for each of the following.

- a) The other function values for ϕ
 b) The six function values for $\pi/2 - \phi$
 c) The six function values for $\phi + \pi/2$

Find an equivalent expression for each of the following.

5. $\sec\left(x + \frac{\pi}{2}\right)$ 6. $\cot\left(x - \frac{\pi}{2}\right)$

7. $\tan\left(x - \frac{\pi}{2}\right)$ 8. $\csc\left(x + \frac{\pi}{2}\right)$

Find the exact value of $\sin 2\theta$, $\cos 2\theta$, $\tan 2\theta$, and the quadrant in which 2θ lies.

9. $\sin \theta = \frac{4}{5}$, θ in quadrant I
 10. $\cos \theta = \frac{5}{13}$, θ in quadrant I
 11. $\cos \theta = -\frac{3}{5}$, θ in quadrant III
 12. $\tan \theta = -\frac{15}{8}$, θ in quadrant II

13. $\tan \theta = -\frac{5}{12}$, θ in quadrant II

14. $\sin \theta = -\frac{\sqrt{10}}{10}$, θ in quadrant IV

15. Find an equivalent expression for $\cos 4x$ in terms of function values of x .

16. Find an equivalent expression for $\sin^4 \theta$ in terms of function values of θ , 2θ , or 4θ , raised only to the first power.

Use the half-angle identities to evaluate exactly.

17. $\cos 15^\circ$ 18. $\tan 67.5^\circ$

19. $\sin 112.5^\circ$ 20. $\cos \frac{\pi}{8}$

21. $\tan 75^\circ$ 22. $\sin \frac{5\pi}{12}$

Given that $\sin \theta = 0.3416$ and θ is in quadrant I, find each of the following using identities.

23. $\sin 2\theta$ 24. $\cos \frac{\theta}{2}$

25. $\sin \frac{\theta}{2}$ 26. $\sin 4\theta$

Simplify.

27. $2 \cos^2 \frac{x}{2} - 1$

28. $\cos^4 x - \sin^4 x$

29. $(\sin x - \cos x)^2 + \sin 2x$

30. $(\sin x + \cos x)^2$

31. $\frac{2 - \sec^2 x}{\sec^2 x}$

32. $\frac{1 + \sin 2x + \cos 2x}{1 + \sin 2x - \cos 2x}$

33. $(-4 \cos x \sin x + 2 \cos 2x)^2 + (2 \cos 2x + 4 \sin x \cos x)^2$

34. $2 \sin x \cos^3 x - 2 \sin^3 x \cos x$

Skill Maintenance

Complete the identity.

35. $1 - \cos^2 x =$ 36. $\sec^2 x - \tan^2 x =$
 37. $\sin^2 x - 1 =$ 38. $1 + \cot^2 x =$
 39. $\csc^2 x - \cot^2 x =$ 40. $1 + \tan^2 x =$
 41. $1 - \sin^2 x =$ 42. $\sec^2 x - 1 =$

Consider the following functions (a)–(f). Without graphing them, answer questions 43–46 below.

- a) $f(x) = 2 \sin\left(\frac{1}{2}x - \frac{\pi}{2}\right)$
 b) $f(x) = \frac{1}{2} \cos\left(2x - \frac{\pi}{4}\right) + 2$
 c) $f(x) = -\sin\left[2\left(x - \frac{\pi}{2}\right)\right] + 2$
 d) $f(x) = \sin(x + \pi) - \frac{1}{2}$
 e) $f(x) = -2 \cos(4x - \pi)$
 f) $f(x) = -\cos\left[2\left(x - \frac{\pi}{8}\right)\right]$

43. Which functions have a graph with an amplitude of 2?
 44. Which functions have a graph with a period of π ?
 45. Which functions have a graph with a period of 2π ?
 46. Which functions have a graph with a phase shift of $\frac{\pi}{4}$?

Synthesis

47. Given that $\cos 51^\circ \approx 0.6293$, find the six function values for 141° .

Simplify.

48. $\sin\left(\frac{\pi}{2} - x\right) [\sec x - \cos x]$
 49. $\cos(\pi - x) + \cot x \sin\left(x - \frac{\pi}{2}\right)$

$$50. \frac{\cos x - \sin\left(\frac{\pi}{2} - x\right) \sin x}{\cos x - \cos(\pi - x) \tan x}$$

$$51. \frac{\cos^2 y \sin\left(y + \frac{\pi}{2}\right)}{\sin^2 y \sin\left(\frac{\pi}{2} - y\right)}$$

Find $\sin \theta$, $\cos \theta$, and $\tan \theta$ under the given conditions.

$$52. \cos 2\theta = \frac{7}{12}, \frac{3\pi}{2} \leq 2\theta \leq 2\pi$$

$$53. \tan \frac{\theta}{2} = -\frac{5}{3}, \pi < \theta \leq \frac{3\pi}{2}$$

54. **Nautical Mile.** Latitude is used to measure north–south location on the earth between the equator and the poles. For example, Chicago has latitude 42°N . (See the figure.) In Great Britain, the *nautical mile* is defined as the length of a minute of arc of the earth's radius. Since the earth is flattened slightly at the poles, a British nautical mile varies with latitude. In fact, it is given, in feet, by the function

$$N(\phi) = 6066 - 31 \cos 2\phi,$$

where ϕ is the latitude in degrees.

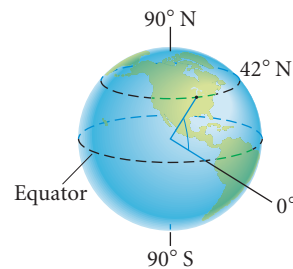

- a) What is the length of a British nautical mile at Chicago?
 b) What is the length of a British nautical mile at the North Pole?
 c) Express $N(\phi)$ in terms of $\cos \phi$ only; that is, do not use the double angle.
55. **Acceleration Due to Gravity.** The acceleration due to gravity is often denoted by g in a formula such as

$S = \frac{1}{2}gt^2$, where S is the distance that an object falls in time t . The number g relates to motion near the earth's surface and is usually considered constant. In fact, however, g is not constant, but varies slightly with latitude. If ϕ stands for latitude, in degrees, g is given with good approximation by the formula

$$g = 9.78049(1 + 0.005288 \sin^2 \phi - 0.000006 \sin^2 2\phi),$$

where g is measured in meters per second per second at sea level.

- a) Chicago has latitude 42°N . Find g .
 b) Philadelphia has latitude 40°N . Find g .

- c) Express g in terms of $\sin \phi$ only. That is, eliminate the double angle.



Proving Trigonometric Identities

7.3

- ▶ Prove identities using other identities.
- ▶ Use the product-to-sum identities and the sum-to-product identities to derive other identities.

▶ The Logic of Proving Identities

We outline two algebraic methods for proving identities.

Method 1. Start with either the left side or the right side of the equation and obtain the other side. For example, suppose you are trying to prove that the equation $P = Q$ is an identity. You might try to produce a string of statements $(R_1, R_2, \dots$ or $T_1, T_2, \dots)$ like the following, which start with P and end with Q or start with Q and end with P :

$$\begin{array}{lcl} P = R_1 & \text{or} & Q = T_1 \\ & & = T_2 \\ & & \vdots \\ & & = P. \\ & & = Q \end{array}$$

Method 2. Work with each side separately until you obtain the same expression. For example, suppose you are trying to prove that $P = Q$ is an identity. You might be able to produce two strings of statements like the following, each ending with the same statement S .

$$\begin{array}{lcl} P = R_1 & & Q = T_1 \\ & & = T_2 \\ & & \vdots \\ & & = S \\ & & = S \end{array}$$

The number of steps in each string might be different, but in each case the result is S .

A first step in learning to prove identities is to have at hand a list of the identities that you have already learned. Such a list is on the inside back cover of this text. Ask your instructor which ones you are expected to memorize. The more identities you prove, the easier it will be to prove new ones. A list of helpful hints follows.

Hints for Proving Identities

1. Use method 1 or method 2:

Method 1: Start with either the left side or the right side of the equation and obtain the other side.

Method 2: Work with each side separately until you obtain the same expression.

2. Work with the more complex side first.
3. Carry out any algebraic manipulations, such as adding, subtracting, multiplying, or factoring.
4. Multiplying by a form of 1 can be helpful when rational expressions are involved.
5. Converting all expressions to sines and cosines is often helpful.
6. Try something! Put your pencil to work and get involved. You will be amazed at how often this leads to success.

► Proving Identities

In what follows, method 1 is used in Examples 1, 3, and 4 and method 2 is used in Examples 2 and 5.

■ STUDY TIP

Forming a small study group (not more than three or four students) can be helpful when learning to prove identities. Your skills with this topic can be greatly improved in group discussions. Retention of the skills can be maximized when you explain the material to someone else.

EXAMPLE 1 Prove the identity $1 + \sin 2\theta = (\sin \theta + \cos \theta)^2$.

Solution Let's use method 1. We begin with the right side and obtain the left side:

$$\begin{aligned} (\sin \theta + \cos \theta)^2 &= \sin^2 \theta + 2 \sin \theta \cos \theta + \cos^2 \theta && \text{Squaring} \\ &= 1 + 2 \sin \theta \cos \theta && \text{Recalling the identity} \\ & && \sin^2 x + \cos^2 x = 1 \text{ and} \\ & && \text{substituting} \\ &= 1 + \sin 2\theta. && \text{Using } \sin 2x = \\ & && 2 \sin x \cos x \end{aligned}$$

We could also begin with the left side and obtain the right side:

$$\begin{aligned} 1 + \sin 2\theta &= 1 + 2 \sin \theta \cos \theta && \text{Using } \sin 2x = 2 \sin x \cos x \\ &= \sin^2 \theta + 2 \sin \theta \cos \theta + \cos^2 \theta && \text{Replacing 1 with} \\ & && \sin^2 \theta + \cos^2 \theta \\ &= (\sin \theta + \cos \theta)^2. && \text{Factoring} \end{aligned}$$

 Now Try Exercise 19.

EXAMPLE 2 Prove the identity

$$\sin^2 x \tan^2 x = \tan^2 x - \sin^2 x.$$

Solution For this proof, we are going to work with each side separately using method 2. We try to obtain the same expression on each side. In actual practice, you might work on one side for a while, then work on the other side, and then go back to the first side. In other words, you work back and forth until you arrive at the same expression. Let's start with the right side.

$$\begin{aligned} \tan^2 x - \sin^2 x &= \frac{\sin^2 x}{\cos^2 x} - \sin^2 x \\ &= \frac{\sin^2 x}{\cos^2 x} - \sin^2 x \cdot \frac{\cos^2 x}{\cos^2 x} \\ &= \frac{\sin^2 x - \sin^2 x \cos^2 x}{\cos^2 x} \\ &= \frac{\sin^2 x (1 - \cos^2 x)}{\cos^2 x} \\ &= \frac{\sin^2 x \sin^2 x}{\cos^2 x} \\ &= \frac{\sin^4 x}{\cos^2 x} \end{aligned}$$

Recalling the identity

$$\tan x = \frac{\sin x}{\cos x} \text{ and}$$

substituting

Multiplying by 1 in order to subtract

Carrying out the subtraction

Factoring

Recalling the identity $1 - \cos^2 x = \sin^2 x$ and substituting

At this point, we stop and work with the left side, $\sin^2 x \tan^2 x$, of the original identity and try to end with the same expression that we ended with on the right side:

$$\begin{aligned} \sin^2 x \tan^2 x &= \sin^2 x \frac{\sin^2 x}{\cos^2 x} \\ &= \frac{\sin^4 x}{\cos^2 x}. \end{aligned}$$

Recalling the identity

$$\tan x = \frac{\sin x}{\cos x} \text{ and substituting}$$

We have obtained the same expression from each side, so the proof is complete.

 Now Try Exercise 25.

EXAMPLE 3 Prove the identity

$$\frac{\sin 2x}{\sin x} - \frac{\cos 2x}{\cos x} = \sec x.$$

Solution

$$\begin{aligned} \frac{\sin 2x}{\sin x} - \frac{\cos 2x}{\cos x} &= \frac{2 \sin x \cos x}{\sin x} - \frac{\cos^2 x - \sin^2 x}{\cos x} \\ &= 2 \cos x - \frac{\cos^2 x - \sin^2 x}{\cos x} \\ &= \frac{2 \cos^2 x}{\cos x} - \frac{\cos^2 x - \sin^2 x}{\cos x} \\ &= \frac{2 \cos^2 x - \cos^2 x + \sin^2 x}{\cos x} \end{aligned}$$

Using double-angle identities

Simplifying

Multiplying $2 \cos x$ by 1, or $\cos x / \cos x$

Subtracting

Continuing, we have

$$\begin{aligned}\frac{2 \cos^2 x - \cos^2 x + \sin^2 x}{\cos x} &= \frac{\cos^2 x + \sin^2 x}{\cos x} \\ &= \frac{1}{\cos x} && \text{Using a Pythagorean identity} \\ &= \sec x && \text{Recalling a basic identity}\end{aligned}$$

 Now Try Exercise 15.

EXAMPLE 4 Prove the identity

$$\frac{\sec t - 1}{t \sec t} = \frac{1 - \cos t}{t}.$$

Solution We use method 1, starting with the left side. Note that the left side involves $\sec t$, whereas the right side involves $\cos t$, so it might be wise to make use of a basic identity that involves these two expressions: $\sec t = 1/\cos t$.

$$\begin{aligned}\frac{\sec t - 1}{t \sec t} &= \frac{\frac{1}{\cos t} - 1}{t \frac{1}{\cos t}} && \text{Substituting } 1/\cos t \text{ for } \sec t \\ &= \left(\frac{1}{\cos t} - 1 \right) \cdot \frac{\cos t}{t} \\ &= \frac{1}{t} - \frac{\cos t}{t} && \text{Multiplying} \\ &= \frac{1 - \cos t}{t}\end{aligned}$$

We started with the left side and obtained the right side, so the proof is complete.

 Now Try Exercise 5.

EXAMPLE 5 Prove the identity

$$\cot \phi + \csc \phi = \frac{\sin \phi}{1 - \cos \phi}.$$

Solution We are again using method 2, beginning with the left side:

$$\begin{aligned}\cot \phi + \csc \phi &= \frac{\cos \phi}{\sin \phi} + \frac{1}{\sin \phi} && \text{Using basic identities} \\ &= \frac{1 + \cos \phi}{\sin \phi}. && \text{Adding}\end{aligned}$$

At this point, we stop and work with the right side of the original identity:

$$\begin{aligned}\frac{\sin \phi}{1 - \cos \phi} &= \frac{\sin \phi}{1 - \cos \phi} \cdot \frac{1 + \cos \phi}{1 + \cos \phi} && \text{Multiplying by 1} \\ &= \frac{\sin \phi (1 + \cos \phi)}{1 - \cos^2 \phi}\end{aligned}$$

$$\begin{aligned}
 &= \frac{\sin \phi (1 + \cos \phi)}{\sin^2 \phi} && \text{Using } \sin^2 x = 1 - \cos^2 x \\
 &= \frac{1 + \cos \phi}{\sin \phi}. && \text{Simplifying}
 \end{aligned}$$

The proof is complete since we obtained the same expression from each side.

 **Now Try Exercise 29.**

► Product-to-Sum and Sum-to-Product Identities

On occasion, it is convenient to convert a product of trigonometric expressions to a sum, or the reverse. The following identities are useful in this connection.

Product-to-Sum Identities

$$\sin x \cdot \sin y = \frac{1}{2} [\cos (x - y) - \cos (x + y)] \quad (1)$$

$$\cos x \cdot \cos y = \frac{1}{2} [\cos (x - y) + \cos (x + y)] \quad (2)$$

$$\sin x \cdot \cos y = \frac{1}{2} [\sin (x + y) + \sin (x - y)] \quad (3)$$

$$\cos x \cdot \sin y = \frac{1}{2} [\sin (x + y) - \sin (x - y)] \quad (4)$$

We can derive product-to-sum identities (1) and (2) using the sum and difference identities for the cosine function:

$$\cos (x + y) = \cos x \cos y - \sin x \sin y, \quad \text{Sum identity}$$

$$\cos (x - y) = \cos x \cos y + \sin x \sin y. \quad \text{Difference identity}$$

Subtracting the sum identity from the difference identity, we have

$$\cos (x - y) - \cos (x + y) = 2 \sin x \sin y \quad \text{Subtracting}$$

$$\frac{1}{2} [\cos (x - y) - \cos (x + y)] = \sin x \sin y. \quad \text{Multiplying by } \frac{1}{2}$$

Thus, $\sin x \sin y = \frac{1}{2} [\cos (x - y) - \cos (x + y)]$.

Adding the cosine sum and difference identities, we have

$$\cos (x - y) + \cos (x + y) = 2 \cos x \cos y \quad \text{Adding}$$

$$\frac{1}{2} [\cos (x - y) + \cos (x + y)] = \cos x \cos y. \quad \text{Multiplying by } \frac{1}{2}$$

Thus, $\cos x \cos y = \frac{1}{2} [\cos (x - y) + \cos (x + y)]$.

Identities (3) and (4) can be derived in a similar manner using the sum and difference identities for the sine function.

EXAMPLE 6 Find an identity for $2 \sin 3\theta \cos 7\theta$.

Solution We will use the identity

$$\sin x \cdot \cos y = \frac{1}{2} [\sin(x + y) + \sin(x - y)].$$

Here $x = 3\theta$ and $y = 7\theta$. Thus,

$$\begin{aligned} 2 \sin 3\theta \cos 7\theta &= 2 \cdot \frac{1}{2} [\sin(3\theta + 7\theta) + \sin(3\theta - 7\theta)] \\ &= \sin 10\theta + \sin(-4\theta) \\ &= \sin 10\theta - \sin 4\theta. \end{aligned} \quad \text{Using } \sin(-\theta) = -\sin \theta$$

 **Now Try Exercise 37.**

Sum-to-Product Identities

$$\sin x + \sin y = 2 \sin \frac{x + y}{2} \cos \frac{x - y}{2} \quad (5)$$

$$\sin x - \sin y = 2 \cos \frac{x + y}{2} \sin \frac{x - y}{2} \quad (6)$$

$$\cos y + \cos x = 2 \cos \frac{x + y}{2} \cos \frac{x - y}{2} \quad (7)$$

$$\cos y - \cos x = 2 \sin \frac{x + y}{2} \sin \frac{x - y}{2} \quad (8)$$

The sum-to-product identities (5)–(8) can be derived using the product-to-sum identities. Proofs are left to the exercises.

EXAMPLE 7 Find an identity for $\cos \theta + \cos 5\theta$.

Solution We will use the identity

$$\cos y + \cos x = 2 \cos \frac{x + y}{2} \cos \frac{x - y}{2}.$$

Here $x = 5\theta$ and $y = \theta$. Thus,

$$\begin{aligned} \cos \theta + \cos 5\theta &= 2 \cos \frac{5\theta + \theta}{2} \cos \frac{5\theta - \theta}{2} \\ &= 2 \cos 3\theta \cos 2\theta. \end{aligned}$$

 **Now Try Exercise 35.**

7.3

Exercise Set

Prove the identity.

1. $\sec x - \sin x \tan x = \cos x$

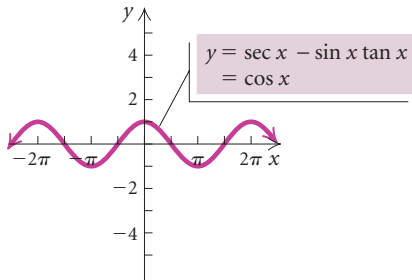

2. $\frac{1 + \cos \theta}{\sin \theta} + \frac{\sin \theta}{\cos \theta} = \frac{\cos \theta + 1}{\sin \theta \cos \theta}$

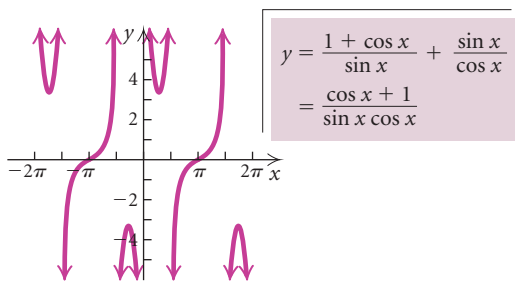

3. $\frac{1 - \cos x}{\sin x} = \frac{\sin x}{1 + \cos x}$

4. $\frac{1 + \tan y}{1 + \cot y} = \frac{\sec y}{\csc y}$

5. $\frac{1 + \tan \theta}{1 - \tan \theta} + \frac{1 + \cot \theta}{1 - \cot \theta} = 0$

6. $\frac{\sin x + \cos x}{\sec x + \csc x} = \frac{\sin x}{\sec x}$

7. $\frac{\cos^2 \alpha + \cot \alpha}{\cos^2 \alpha - \cot \alpha} = \frac{\cos^2 \alpha \tan \alpha + 1}{\cos^2 \alpha \tan \alpha - 1}$

8. $\sec 2\theta = \frac{\sec^2 \theta}{2 - \sec^2 \theta}$

9. $\frac{2 \tan \theta}{1 + \tan^2 \theta} = \sin 2\theta$

10. $\frac{\cos(u - v)}{\cos u \sin v} = \tan u + \cot v$

11. $1 - \cos 5\theta \cos 3\theta - \sin 5\theta \sin 3\theta = 2 \sin^2 \theta$

12. $\cos^4 x - \sin^4 x = \cos 2x$

13. $2 \sin \theta \cos^3 \theta + 2 \sin^3 \theta \cos \theta = \sin 2\theta$

14. $\frac{\tan 3t - \tan t}{1 + \tan 3t \tan t} = \frac{2 \tan t}{1 - \tan^2 t}$

15. $\frac{\tan x - \sin x}{2 \tan x} = \sin^2 \frac{x}{2}$

16. $\frac{\cos^3 \beta - \sin^3 \beta}{\cos \beta - \sin \beta} = \frac{2 + \sin 2\beta}{2}$

17. $\sin(\alpha + \beta) \sin(\alpha - \beta) = \sin^2 \alpha - \sin^2 \beta$

18. $\cos^2 x (1 - \sec^2 x) = -\sin^2 x$

19. $\tan \theta (\tan \theta + \cot \theta) = \sec^2 \theta$

20. $\frac{\cos \theta + \sin \theta}{\cos \theta} = 1 + \tan \theta$

21. $\frac{1 + \cos^2 x}{\sin^2 x} = 2 \csc^2 x - 1$

22. $\frac{\tan y + \cot y}{\csc y} = \sec y$

23. $\frac{1 + \sin x}{1 - \sin x} + \frac{\sin x - 1}{1 + \sin x} = 4 \sec x \tan x$

24. $\tan \theta - \cot \theta = (\sec \theta - \csc \theta)(\sin \theta + \cos \theta)$

25. $\cos^2 \alpha \cot^2 \alpha = \cot^2 \alpha - \cos^2 \alpha$

26. $\frac{\tan x + \cot x}{\sec x + \csc x} = \frac{1}{\cos x + \sin x}$

27. $2 \sin^2 \theta \cos^2 \theta + \cos^4 \theta = 1 - \sin^4 \theta$

28. $\frac{\cot \theta}{\csc \theta - 1} = \frac{\csc \theta + 1}{\cot \theta}$

29. $\frac{1 + \sin x}{1 - \sin x} = (\sec x + \tan x)^2$

30. $\sec^4 s - \tan^2 s = \tan^4 s + \sec^2 s$

31. Verify the product-to-sum identities (3) and (4) using the sine sum and difference identities.

32. Verify the sum-to-product identities (5)–(8) using the product-to-sum identities (1)–(4).

Use the product-to-sum identities and the sum-to-product identities to find identities for each of the following.

33. $\sin 3\theta - \sin 5\theta$ 34. $\sin 7x - \sin 4x$
 35. $\sin 8\theta + \sin 5\theta$ 36. $\cos \theta - \cos 7\theta$
 37. $\sin 7u \sin 5u$ 38. $2 \sin 7\theta \cos 3\theta$
 39. $7 \cos \theta \sin 7\theta$ 40. $\cos 2t \sin t$
 41. $\cos 55^\circ \sin 25^\circ$ 42. $7 \cos 5\theta \cos 7\theta$

Use the product-to-sum identities and the sum-to-product identities to prove each of the following.

43. $\sin 4\theta + \sin 6\theta = \cot \theta (\cos 4\theta - \cos 6\theta)$
 44. $\tan 2x (\cos x + \cos 3x) = \sin x + \sin 3x$
 45. $\cot 4x (\sin x + \sin 4x + \sin 7x)$
 $= \cos x + \cos 4x + \cos 7x$
 46. $\tan \frac{x+y}{2} = \frac{\sin x + \sin y}{\cos x + \cos y}$
 47. $\cot \frac{x+y}{2} = \frac{\sin y - \sin x}{\cos x - \cos y}$
 48. $\tan \frac{\theta + \phi}{2} \tan \frac{\phi - \theta}{2} = \frac{\cos \theta - \cos \phi}{\cos \theta + \cos \phi}$
 49. $\tan \frac{\theta + \phi}{2} (\sin \theta - \sin \phi)$
 $= \tan \frac{\theta - \phi}{2} (\sin \theta + \sin \phi)$
 50. $\sin 2\theta + \sin 4\theta + \sin 6\theta = 4 \cos \theta \cos 2\theta \sin 3\theta$

Skill Maintenance

For each function:

- a) Graph the function.
 b) Determine whether the function is one-to-one.
 c) If the function is one-to-one, find an equation for its inverse.
 d) Graph the inverse of the function.

51. $f(x) = 3x - 2$ 52. $f(x) = x^3 + 1$
 53. $f(x) = x^2 - 4, x \geq 0$ 54. $f(x) = \sqrt{x + 2}$

Solve.

55. $2x^2 = 5x$
 56. $3x^2 + 5x - 10 = 18$

57. $x^4 + 5x^2 - 36 = 0$
 58. $x^2 - 10x + 1 = 0$
 59. $\sqrt{x - 2} = 5$
 60. $x = \sqrt{x + 7} + 5$

Synthesis

Prove the identity.

61. $\ln |\tan x| = -\ln |\cot x|$
 62. $\ln |\sec \theta + \tan \theta| = -\ln |\sec \theta - \tan \theta|$
 63. $\log (\cos x - \sin x) + \log (\cos x + \sin x)$
 $= \log \cos 2x$

64. **Mechanics.** The following equation occurs in the study of mechanics:

$$\sin \theta = \frac{I_1 \cos \phi}{\sqrt{(I_1 \cos \phi)^2 + (I_2 \sin \phi)^2}}$$

It can happen that $I_1 = I_2$. Assuming that this happens, simplify the equation.

65. **Alternating Current.** In the theory of alternating current, the following equation occurs:

$$R = \frac{1}{\omega C (\tan \theta + \tan \phi)}$$

Show that this equation is equivalent to

$$R = \frac{\cos \theta \cos \phi}{\omega C \sin (\theta + \phi)}$$

66. **Electrical Theory.** In electrical theory, the following equations occur:

$$E_1 = \sqrt{2}E_t \cos \left(\theta + \frac{\pi}{P} \right)$$

and

$$E_2 = \sqrt{2}E_t \cos \left(\theta - \frac{\pi}{P} \right)$$

Assuming that these equations hold, show that

$$\frac{E_1 + E_2}{2} = \sqrt{2}E_t \cos \theta \cos \frac{\pi}{P}$$

and

$$\frac{E_1 - E_2}{2} = -\sqrt{2}E_t \sin \theta \sin \frac{\pi}{P}$$

Mid-Chapter Mixed Review

Determine whether the statement is true or false.

1. $\sin x (\csc x - \cot x) = 1 - \cos x$ [7.1]

2. $\sin 42^\circ = \sqrt{\frac{1 + \cos 84^\circ}{2}}$ [7.2]

3. $\sin \frac{\pi}{9} = \cos \frac{7\pi}{18}$ [7.2]

4. $\cos^2 x \neq \cos x^2$ [7.1]

For Exercises 5–14 choose an expression from expressions A–J to complete the identity. [7.1], [7.2]

5. $\cos(-x) =$

10. $\sin \frac{x}{2} =$

A. $2 \sin x \cos x$

F. $\sec x$

6. $\cos(u + v) =$

11. $\sin 2x =$

B. $\pm \sqrt{\frac{1 + \cos x}{2}}$

G. $\sin u \cos v - \cos u \sin v$

7. $\tan 2x =$

12. $\sin(u - v) =$

C. $\csc^2 x$

H. $\cos u \cos v - \sin u \sin v$

8. $\tan\left(\frac{\pi}{2} - x\right) =$

13. $\csc\left(\frac{\pi}{2} - x\right) =$

D. $\frac{2 \tan x}{1 - \tan^2 x}$

I. $\cot x$

9. $1 + \cot^2 x =$

14. $\cos \frac{x}{2} =$

E. $\pm \sqrt{\frac{1 - \cos x}{2}}$

J. $\cos x$

Simplify.

15. $\sqrt{\frac{\cot x}{\sin x}}$ [7.1]

16. $\frac{1}{\sin^2 x} - \left(\frac{\cos x}{\sin x}\right)^2$ [7.1]

17. $\frac{2 \cos^2 x - 5 \cos x - 3}{\cos x - 3}$ [7.1]

18. $\frac{\sin x}{\tan(-x)}$ [7.1]

19. $(\cos x - \sin x)^2$ [7.2]

20. $1 - 2 \sin^2 \frac{x}{2}$ [7.2]

21. Rationalize the denominator:

$$\sqrt{\frac{\sec x}{1 - \cos x}}$$
 [7.1]

22. Write $\cos 41^\circ \cos 29^\circ + \sin 41^\circ \sin 29^\circ$ as a trigonometric function of a single angle and then evaluate. [7.1]

23. Evaluate $\cos \frac{3\pi}{8}$ exactly. [7.1]

24. Evaluate $\sin 105^\circ$ exactly. [7.1]

25. Assume that $\sin \alpha = \frac{5}{13}$ and $\sin \beta = \frac{12}{13}$ and that α and β are between 0 and $\pi/2$, and evaluate $\tan(\alpha - \beta)$. [7.1]

26. Find the exact value of $\sin 2\theta$ and the quadrant in which 2θ lies if $\cos \theta = -\frac{4}{5}$, with θ in quadrant II. [7.2]

Prove the identity. [7.3]

27. $\cos^2 \frac{x}{2} = \frac{\tan x + \sin x}{2 \tan x}$

28. $\frac{1 - \sin x}{\cos x} = \frac{\cos x}{1 + \sin x}$

29. $\frac{\sin^3 x - \cos^3 x}{\sin x - \cos x} = \frac{2 + \sin 2x}{2}$

30. $\sin 6\theta - \sin 2\theta = \tan 2\theta (\cos 2\theta + \cos 6\theta)$

Collaborative Discussion and Writing

31. Explain why $\tan(x + 450^\circ)$ cannot be simplified using the tangent sum formula, but can be simplified using the sine and cosine sum formulas. [7.1]
32. Discuss and compare the graphs of $y = \sin x$, $y = \sin 2x$, and $y = \sin(x/2)$. [7.2]
33. What restrictions must be placed on the variable in each of the following identities? Why? [7.3]
- a) $\sin 2x = \frac{2 \tan x}{1 + \tan^2 x}$
- b) $\frac{1 - \cos x}{\sin x} = \frac{\sin x}{1 + \cos x}$
34. Find all errors in the following:
- $$2 \sin^2 2x + \cos 4x$$
- $$= 2(2 \sin x \cos x)^2 + 2 \cos 2x$$
- $$= 8 \sin^2 x \cos^2 x + 2(\cos^2 x + \sin^2 x)$$
- $$= 8 \sin^2 x \cos^2 x + 2. \quad [7.2]$$

Inverses of the Trigonometric Functions

7.4

- ▶ Find values of the inverse trigonometric functions.
- ▶ Simplify expressions such as $\sin(\sin^{-1} x)$ and $\sin^{-1}(\sin x)$.
- ▶ Simplify expressions involving compositions such as $\sin(\cos^{-1} \frac{1}{2})$ without using a calculator.
- ▶ Simplify expressions such as $\sin \arctan(a/b)$ by making a drawing and reading off appropriate ratios.

In this section, we develop inverse trigonometric functions. The graphs of the sine, cosine, and tangent functions follow. Do these functions have inverses that are functions? They do have inverses if they are one-to-one, which means that they pass the horizontal-line test.

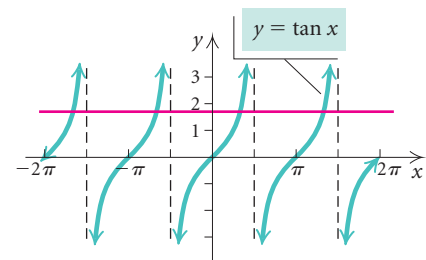
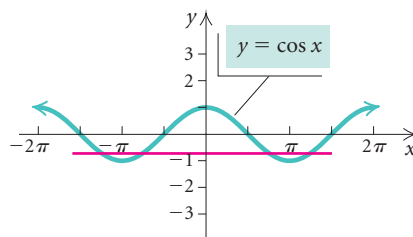
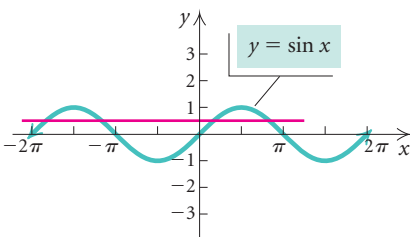

INVERSE FUNCTIONS

REVIEW SECTION 5.1

Note that for each function, a horizontal line (shown in red) crosses the graph more than once. Therefore, none of them has an inverse that is a function.

The graphs of an equation and its inverse are reflections of each other across the line $y = x$. Let's examine the graphs of the inverses of each of the three functions graphed above.

STUDY TIP

When you study a section of a mathematics text, read it slowly, observing all the details of the corresponding art pieces that are discussed in the paragraphs. Also note the precise color-coding in the art that enhances the learning of the concepts.

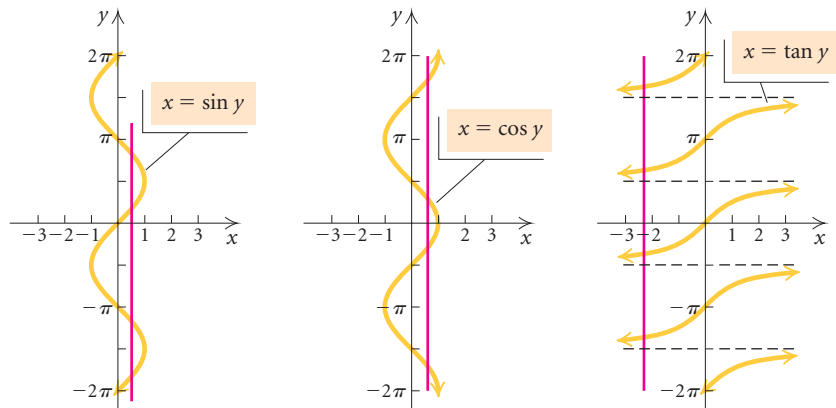

We can check again to see whether these are graphs of functions by using the vertical-line test. In each case, there is a vertical line (shown in red) that crosses the graph more than once, so each *fails* to be a function.

Restricting Ranges to Define Inverse Functions

Recall that a function like $f(x) = x^2$ does not have an inverse that is a function, but by restricting the domain of f to nonnegative numbers, we have a new squaring function, $f(x) = x^2, x \geq 0$, that has an inverse, $f^{-1}(x) = \sqrt{x}$. This is equivalent to restricting the range of the inverse relation to exclude ordered pairs that contain negative numbers.

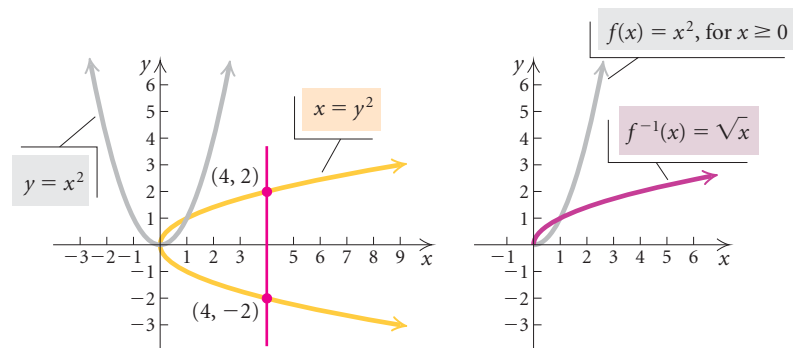

In a similar manner, we can define new trigonometric functions whose inverses are functions. We can do this by restricting either the domains of the basic trigonometric functions or the ranges of their inverse relations.

This can be done in many ways, but the restrictions illustrated below with solid red curves are fairly standard in mathematics.

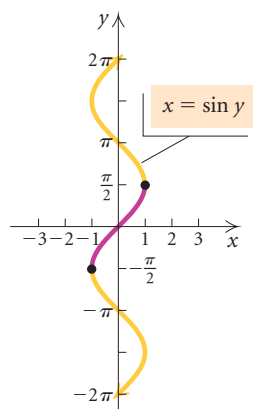

Figure 1

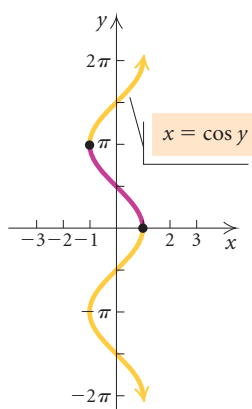

Figure 2

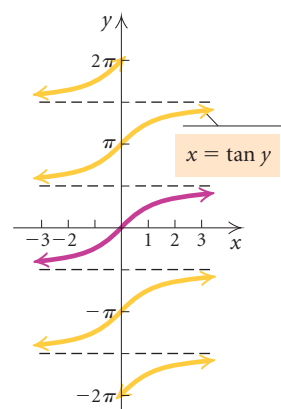

Figure 3

For the inverse sine function, we choose a range close to the origin that allows all inputs on the interval $[-1, 1]$ to have function values. Thus we choose the interval $[-\pi/2, \pi/2]$ for the range (Fig. 1). For the inverse cosine function, we choose a range close to the origin that allows all inputs on the interval $[-1, 1]$ to have function values. We choose the interval $[0, \pi]$ (Fig. 2). For the inverse tangent function, we choose a range close to the origin that allows all real numbers to have function values. The interval $(-\pi/2, \pi/2)$ satisfies this requirement (Fig. 3).

Inverse Trigonometric Functions

FUNCTION	DOMAIN	RANGE
$y = \sin^{-1} x$ = arcsin x , where $x = \sin y$	$[-1, 1]$	$[-\pi/2, \pi/2]$
$y = \cos^{-1} x$ = arccos x , where $x = \cos y$	$[-1, 1]$	$[0, \pi]$
$y = \tan^{-1} x$ = arctan x , where $x = \tan y$	$(-\infty, \infty)$	$(-\pi/2, \pi/2)$

The notation arcsin x arises because the function value, y , is the length of an arc on the unit circle for which the sine is x . Either of the two kinds of notation above can be read “the inverse sine of x ” or “the arcsine of x ” or “the number (or angle) whose sine is x .”

CAUTION! The notation $\sin^{-1} x$ is *not* exponential notation.

It does *not* mean $\frac{1}{\sin x}$!

TECHNOLOGY CONNECTION

Inverse trigonometric functions can be graphed using a graphing calculator. Graph $y = \sin^{-1} x$ using the viewing window $[-3, 3, -\pi, \pi]$, with $Xscl = 1$ and $Yscl = \pi/2$. Now try graphing $y = \cos^{-1} x$ and $y = \tan^{-1} x$. Then use the graphs to confirm the domain and the range of each inverse.

The graphs of the inverse trigonometric functions are as follows.

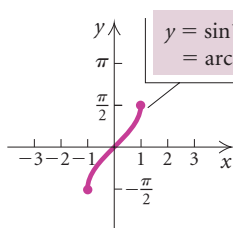

Domain: $[-1, 1]$
Range: $[-\frac{\pi}{2}, \frac{\pi}{2}]$

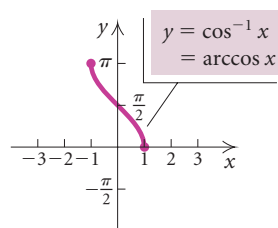

Domain: $[-1, 1]$
Range: $[0, \pi]$

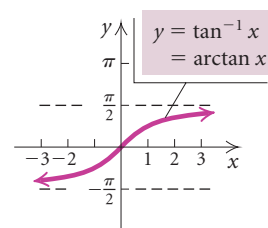

Domain: $(-\infty, \infty)$
Range: $(-\frac{\pi}{2}, \frac{\pi}{2})$

The following diagrams show the restricted ranges for the inverse trigonometric functions on a unit circle. Compare these graphs with the graphs above. The ranges of these functions should be memorized. The missing endpoints in the graph of the arctangent function indicate inputs that are not in the domain of the original function.

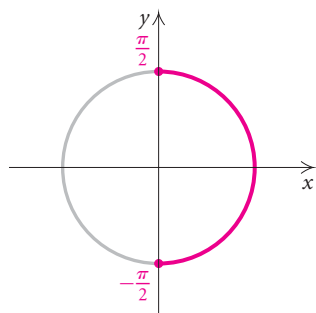

arcsine
Range $[-\frac{\pi}{2}, \frac{\pi}{2}]$

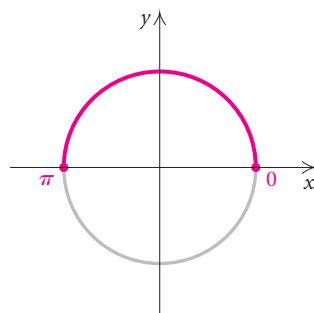

arccosine
Range $[0, \pi]$

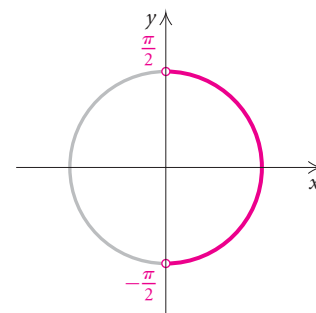

arctangent
Range $(-\frac{\pi}{2}, \frac{\pi}{2})$

EXAMPLE 1 Find each of the following function values.

a) $\sin^{-1} \frac{\sqrt{2}}{2}$

b) $\cos^{-1} \left(-\frac{1}{2}\right)$

c) $\tan^{-1} \left(-\frac{\sqrt{3}}{3}\right)$

Solution

a) Another way to state “find $\sin^{-1} \sqrt{2}/2$ ” is to say “find β such that $\sin \beta = \sqrt{2}/2$.” In the restricted range $[-\pi/2, \pi/2]$, the only number with a sine of $\sqrt{2}/2$ is $\pi/4$. Thus, $\sin^{-1}(\sqrt{2}/2) = \pi/4$, or 45° . (See Fig. 4 below.)

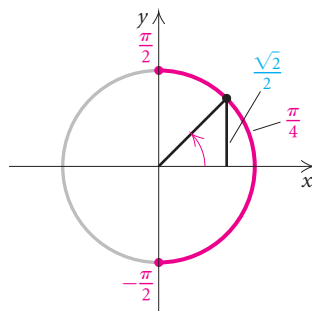

Figure 4

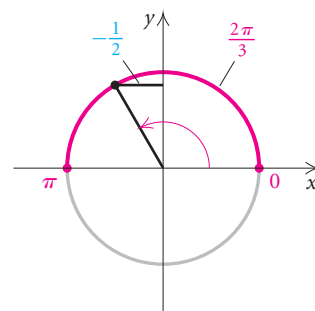

Figure 5

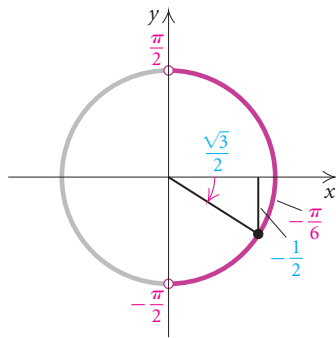

Figure 6

- b) The only number with a cosine of $-\frac{1}{2}$ in the restricted range $[0, \pi]$ is $2\pi/3$. Thus, $\cos^{-1}\left(-\frac{1}{2}\right) = 2\pi/3$, or 120° . (See Fig. 5 on the preceding page.)
- c) The only number in the restricted range $(-\pi/2, \pi/2)$ with a tangent of $-\sqrt{3}/3$ is $-\pi/6$. Thus, $\tan^{-1}\left(-\sqrt{3}/3\right)$ is $-\pi/6$, or -30° . (See Fig. 6 at left.)

➔ Now Try Exercises 1 and 5.

We can also use a calculator to find inverse trigonometric function values. On most graphing calculators, we can find inverse function values in either radians or degrees simply by selecting the appropriate mode. The keystrokes involved in finding inverse function values vary with the calculator. Be sure to read the instructions for the particular calculator that you are using.

EXAMPLE 2 Approximate each of the following function values in both radians and degrees. Round radian measure to four decimal places and degree measure to the nearest tenth of a degree.

- a) $\cos^{-1}(-0.2689)$ b) $\tan^{-1}(-0.2623)$
 c) $\sin^{-1} 0.20345$ d) $\cos^{-1} 1.318$
 e) $\csc^{-1} 8.205$

Solution

FUNCTION VALUE	MODE	READOUT	ROUNDED
a) $\cos^{-1}(-0.2689)$	Radian	1.843047111	1.8430
	Degree	105.5988209	105.6°
b) $\tan^{-1}(-0.2623)$	Radian	-.2565212141	-0.2565
	Degree	-14.69758292	-14.7°
c) $\sin^{-1} 0.20345$	Radian	.2048803359	0.2049
	Degree	11.73877855	11.7°
d) $\cos^{-1} 1.318$	Radian	ERR:DOMAIN	
	Degree	ERR:DOMAIN	

The value 1.318 is not in $[-1, 1]$, the domain of the arccosine function.

- e) The cosecant function is the reciprocal of the sine function:

$$\csc^{-1} 8.205 =$$

$\sin^{-1}(1/8.205)$	Radian	.1221806653	0.1222
	Degree	7.000436462	7.0°

➔ Now Try Exercises 21 and 25.

CONNECTING THE CONCEPTS

Domains and Ranges

The following is a summary of the domains and ranges of the trigonometric functions together with a summary of the domains and ranges of the inverse trigonometric functions. For completeness, we have included the arcsecant, the arccotangent, and the arccosecant, though there is a lack of uniformity in their definitions in mathematical literature.

FUNCTION	DOMAIN	RANGE
\sin	All reals, $(-\infty, \infty)$	$[-1, 1]$
\cos	All reals, $(-\infty, \infty)$	$[-1, 1]$
\tan	All reals except $k\pi/2$, k odd	All reals, $(-\infty, \infty)$
\csc	All reals except $k\pi$	$(-\infty, -1] \cup [1, \infty)$
\sec	All reals except $k\pi/2$, k odd	$(-\infty, -1] \cup [1, \infty)$
\cot	All reals except $k\pi$	All reals, $(-\infty, \infty)$
INVERSE FUNCTION	DOMAIN	RANGE
\sin^{-1}	$[-1, 1]$	$\left[-\frac{\pi}{2}, \frac{\pi}{2}\right]$
\cos^{-1}	$[-1, 1]$	$[0, \pi]$
\tan^{-1}	All reals, or $(-\infty, \infty)$	$\left(-\frac{\pi}{2}, \frac{\pi}{2}\right)$
\csc^{-1}	$(-\infty, -1] \cup [1, \infty)$	$\left[-\frac{\pi}{2}, 0\right) \cup \left(0, \frac{\pi}{2}\right]$
\sec^{-1}	$(-\infty, -1] \cup [1, \infty)$	$\left[0, \frac{\pi}{2}\right) \cup \left(\frac{\pi}{2}, \pi\right]$
\cot^{-1}	All reals, or $(-\infty, \infty)$	$(0, \pi)$

Composition of Trigonometric Functions and Their Inverses

Various compositions of trigonometric functions and their inverses often occur in practice. For example, we might want to try to simplify an expression such as

$$\sin(\sin^{-1} x) \quad \text{or} \quad \sin\left(\cot^{-1} \frac{x}{2}\right).$$

COMPOSITION OF FUNCTIONS

REVIEW SECTION 2.3

In the expression on the left, we are finding “the sine of a number whose sine is x .” Recall from Section 5.1 that if a function f has an inverse that is also a function, then

$$f(f^{-1}(x)) = x, \quad \text{for all } x \text{ in the domain of } f^{-1},$$

and

$$f^{-1}(f(x)) = x, \quad \text{for all } x \text{ in the domain of } f.$$

Thus, if $f(x) = \sin x$ and $f^{-1}(x) = \sin^{-1} x$, then

$$\sin(\sin^{-1} x) = x, \quad \text{for all } x \text{ in the domain of } \sin^{-1},$$

which is any number on the interval $[-1, 1]$. Similar results hold for the other trigonometric functions.

Composition of Trigonometric Functions

$$\sin(\sin^{-1} x) = x, \quad \text{for all } x \text{ in the domain of } \sin^{-1}.$$

$$\cos(\cos^{-1} x) = x, \quad \text{for all } x \text{ in the domain of } \cos^{-1}.$$

$$\tan(\tan^{-1} x) = x, \quad \text{for all } x \text{ in the domain of } \tan^{-1}.$$

EXAMPLE 3 Simplify each of the following.

a) $\cos\left(\cos^{-1}\frac{\sqrt{3}}{2}\right)$ b) $\sin(\sin^{-1} 1.8)$

Solution

a) Since $\sqrt{3}/2$ is in $[-1, 1]$, the domain of \cos^{-1} , it follows that

$$\cos\left(\cos^{-1}\frac{\sqrt{3}}{2}\right) = \frac{\sqrt{3}}{2}.$$

b) Since 1.8 is not in $[-1, 1]$, the domain of \sin^{-1} , we cannot evaluate this expression. We know that there is no number with a sine of 1.8. Since we cannot find $\sin^{-1} 1.8$, we state that $\sin(\sin^{-1} 1.8)$ does not exist.

 **Now Try Exercise 37.**

Now let's consider an expression like $\sin^{-1}(\sin x)$. We might also suspect that this is equal to x for any x in the domain of $\sin x$, but this is not true unless x is in the range of the \sin^{-1} function. Note that in order to define \sin^{-1} , we had to restrict the domain of the sine function. In doing so, we restricted the range of the inverse sine function. Thus,

$$\sin^{-1}(\sin x) = x, \quad \text{for all } x \text{ in the range of } \sin^{-1}.$$

Similar results hold for the other trigonometric functions.

Special Cases

$$\sin^{-1}(\sin x) = x, \quad \text{for all } x \text{ in the range of } \sin^{-1}.$$

$$\cos^{-1}(\cos x) = x, \quad \text{for all } x \text{ in the range of } \cos^{-1}.$$

$$\tan^{-1}(\tan x) = x, \quad \text{for all } x \text{ in the range of } \tan^{-1}.$$

EXAMPLE 4 Simplify each of the following.

a) $\tan^{-1}\left(\tan \frac{\pi}{6}\right)$ b) $\sin^{-1}\left(\sin \frac{3\pi}{4}\right)$

Solution

a) Since $\pi/6$ is in $(-\pi/2, \pi/2)$, the range of the \tan^{-1} function, we can use $\tan^{-1}(\tan x) = x$. Thus,

$$\tan^{-1}\left(\tan \frac{\pi}{6}\right) = \frac{\pi}{6}.$$

b) Note that $3\pi/4$ is not in $[-\pi/2, \pi/2]$, the range of the \sin^{-1} function. Thus we *cannot* apply $\sin^{-1}(\sin x) = x$. Instead we first find $\sin(3\pi/4)$, which is $\sqrt{2}/2$, and substitute:

$$\sin^{-1}\left(\sin \frac{3\pi}{4}\right) = \sin^{-1}\left(\frac{\sqrt{2}}{2}\right) = \frac{\pi}{4}.$$

➔ **Now Try Exercise 43.**

Now we find some other function compositions.

EXAMPLE 5 Simplify each of the following.

a) $\sin[\tan^{-1}(-1)]$ b) $\cos^{-1}\left(\sin \frac{\pi}{2}\right)$

Solution

a) $\tan^{-1}(-1)$ is the number (or angle) θ in $(-\pi/2, \pi/2)$ whose tangent is -1 . That is, $\tan \theta = -1$. Thus, $\theta = -\pi/4$ and

$$\sin[\tan^{-1}(-1)] = \sin\left[-\frac{\pi}{4}\right] = -\frac{\sqrt{2}}{2}.$$

b) $\cos^{-1}\left(\sin \frac{\pi}{2}\right) = \cos^{-1}(1) = 0$ **$\sin \frac{\pi}{2} = 1$**

➔ **Now Try Exercises 47 and 49.**

Next, let's consider

$$\cos\left(\sin^{-1}\frac{3}{5}\right).$$

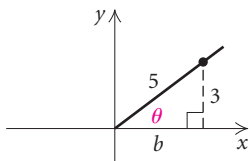

Without using a calculator, we cannot find $\sin^{-1}\frac{3}{5}$. However, we can still evaluate the entire expression by sketching a reference triangle. We are looking for angle θ such that $\sin^{-1}\frac{3}{5} = \theta$, or $\sin \theta = \frac{3}{5}$. Since \sin^{-1} is defined in $[-\pi/2, \pi/2]$ and $\frac{3}{5} > 0$, we know that θ is in quadrant I. We sketch a reference right triangle, as shown at left. The angle θ in this triangle is an angle whose sine is $\frac{3}{5}$. We wish to find the cosine of this angle. Since the triangle is a right triangle, we can find the length of the base, b . It is 4. Thus we know that $\cos \theta = b/5$, or $\frac{4}{5}$. Therefore,

$$\cos\left(\sin^{-1}\frac{3}{5}\right) = \frac{4}{5}.$$

EXAMPLE 6 Find $\sin\left(\cot^{-1}\frac{x}{2}\right)$.

Solution Since \cot^{-1} is defined in $(0, \pi)$, we consider quadrants I and II. We draw right triangles, as shown below, whose legs have lengths x and 2 , so that $\cot \theta = x/2$.

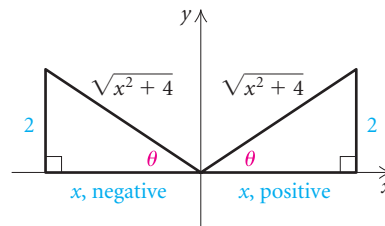

In each, we find the length of the hypotenuse and then read off the sine ratio. We get

$$\sin\left(\cot^{-1}\frac{x}{2}\right) = \frac{2}{\sqrt{x^2 + 4}}.$$

➔ Now Try Exercise 55.

In the following example, we use a sum identity to evaluate an expression.

EXAMPLE 7 Evaluate:

$$\sin\left(\sin^{-1}\frac{1}{2} + \cos^{-1}\frac{5}{13}\right).$$

Solution Since $\sin^{-1}\frac{1}{2}$ and $\cos^{-1}\frac{5}{13}$ are both angles, the expression is the sine of a sum of two angles, so we use the identity

$$\sin(u + v) = \sin u \cos v + \cos u \sin v.$$

Thus,

$$\begin{aligned} & \sin\left(\sin^{-1}\frac{1}{2} + \cos^{-1}\frac{5}{13}\right) \\ &= \sin\left(\sin^{-1}\frac{1}{2}\right) \cdot \cos\left(\cos^{-1}\frac{5}{13}\right) + \cos\left(\sin^{-1}\frac{1}{2}\right) \cdot \sin\left(\cos^{-1}\frac{5}{13}\right) \\ &= \frac{1}{2} \cdot \frac{5}{13} + \cos\left(\sin^{-1}\frac{1}{2}\right) \cdot \sin\left(\cos^{-1}\frac{5}{13}\right). \end{aligned}$$

Using composition identities

Now since $\sin^{-1}\frac{1}{2} = \pi/6$, $\cos\left(\sin^{-1}\frac{1}{2}\right)$ simplifies to $\cos \pi/6$, or $\sqrt{3}/2$. We can illustrate this with a reference triangle in quadrant I.

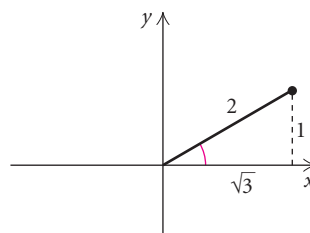

To find $\sin\left(\cos^{-1}\frac{5}{13}\right)$, we use a reference triangle in quadrant I and determine that the sine of the angle whose cosine is $\frac{5}{13}$ is $\frac{12}{13}$.

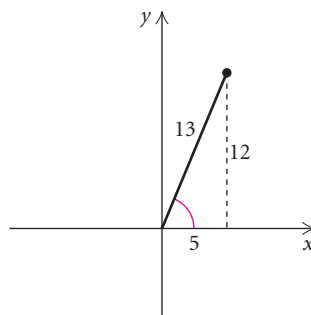

Our expression now simplifies to

$$\frac{1}{2} \cdot \frac{5}{13} + \frac{\sqrt{3}}{2} \cdot \frac{12}{13}, \quad \text{or} \quad \frac{5 + 12\sqrt{3}}{26}.$$

Thus,

$$\sin\left(\sin^{-1}\frac{1}{2} + \cos^{-1}\frac{5}{13}\right) = \frac{5 + 12\sqrt{3}}{26}.$$

Now Try Exercise 63.

7.4

Exercise Set

Find each of the following exactly in radians and degrees.

1. $\sin^{-1}\left(-\frac{\sqrt{3}}{2}\right)$
2. $\cos^{-1}\frac{1}{2}$
3. $\tan^{-1}1$
4. $\sin^{-1}0$
5. $\cos^{-1}\frac{\sqrt{2}}{2}$
6. $\sec^{-1}\sqrt{2}$
7. $\tan^{-1}0$
8. $\tan^{-1}\frac{\sqrt{3}}{3}$
9. $\cos^{-1}\frac{\sqrt{3}}{2}$
10. $\cot^{-1}\left(-\frac{\sqrt{3}}{3}\right)$
11. $\csc^{-1}2$
12. $\sin^{-1}\frac{1}{2}$
13. $\cot^{-1}(-\sqrt{3})$
14. $\tan^{-1}(-1)$
15. $\sin^{-1}\left(-\frac{1}{2}\right)$
16. $\cos^{-1}\left(-\frac{\sqrt{2}}{2}\right)$
17. $\cos^{-1}0$
18. $\sin^{-1}\frac{\sqrt{3}}{2}$
19. $\sec^{-1}2$
20. $\csc^{-1}(-1)$

Use a calculator to find each of the following in radians, rounded to four decimal places, and in degrees, rounded to the nearest tenth of a degree.

21. $\tan^{-1}0.3673$
22. $\cos^{-1}(-0.2935)$
23. $\sin^{-1}0.9613$
24. $\sin^{-1}(-0.6199)$
25. $\cos^{-1}(-0.9810)$
26. $\tan^{-1}158$
27. $\csc^{-1}(-6.2774)$
28. $\sec^{-1}1.1677$
29. $\tan^{-1}(1.091)$
30. $\cot^{-1}1.265$
31. $\sin^{-1}(-0.8192)$
32. $\cos^{-1}(-0.2716)$

33. State the domains of the inverse sine, inverse cosine, and inverse tangent functions.
34. State the ranges of the inverse sine, inverse cosine, and inverse tangent functions.
35. **Angle of Depression.** An airplane is flying at an altitude of 2000 ft toward an island. The straight-line distance from the airplane to the island is d feet. Express θ , the angle of depression, as a function of d .

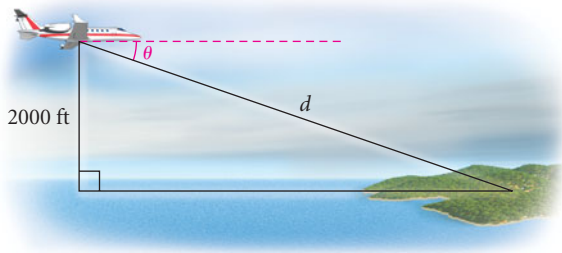

36. **Angle of Inclination.** A guy wire is attached to the top of a 50-ft pole and stretched to a point that is d feet from the bottom of the pole. Express β , the angle of inclination, as a function of d .

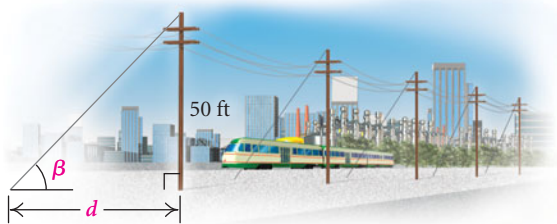

Evaluate.

37. $\sin(\sin^{-1} 0.3)$
38. $\tan[\tan^{-1}(-4.2)]$
39. $\cos^{-1}\left[\cos\left(-\frac{\pi}{4}\right)\right]$
40. $\sin^{-1}\left(\sin\frac{2\pi}{3}\right)$
41. $\sin^{-1}\left(\sin\frac{\pi}{5}\right)$
42. $\cot^{-1}\left(\cot\frac{2\pi}{3}\right)$
43. $\tan^{-1}\left(\tan\frac{2\pi}{3}\right)$
44. $\cos^{-1}\left(\cos\frac{\pi}{7}\right)$
45. $\sin\left(\tan^{-1}\frac{\sqrt{3}}{3}\right)$
46. $\cos\left(\sin^{-1}\frac{\sqrt{3}}{2}\right)$
47. $\tan\left(\cos^{-1}\frac{\sqrt{2}}{2}\right)$
48. $\cos^{-1}(\sin \pi)$
49. $\sin^{-1}\left(\cos\frac{\pi}{6}\right)$
50. $\sin^{-1}\left[\tan\left(-\frac{\pi}{4}\right)\right]$

51. $\tan(\sin^{-1} 0.1)$
52. $\cos\left(\tan^{-1}\frac{\sqrt{3}}{4}\right)$
53. $\sin^{-1}\left(\sin\frac{7\pi}{6}\right)$
54. $\tan^{-1}\left[\tan\left(-\frac{3\pi}{4}\right)\right]$

Find each of the following.

55. $\sin\left(\tan^{-1}\frac{a}{3}\right)$
56. $\tan\left(\cos^{-1}\frac{3}{x}\right)$
57. $\cot\left(\sin^{-1}\frac{p}{q}\right)$
58. $\sin(\cos^{-1} x)$
59. $\tan\left(\sin^{-1}\frac{p}{\sqrt{p^2+9}}\right)$
60. $\tan\left(\frac{1}{2}\sin^{-1}\frac{1}{2}\right)$
61. $\cos\left(\frac{1}{2}\sin^{-1}\frac{\sqrt{3}}{2}\right)$
62. $\sin\left(2\cos^{-1}\frac{3}{5}\right)$

Evaluate.

63. $\cos\left(\sin^{-1}\frac{\sqrt{2}}{2} + \cos^{-1}\frac{3}{5}\right)$
64. $\sin\left(\sin^{-1}\frac{1}{2} + \cos^{-1}\frac{3}{5}\right)$
65. $\sin(\sin^{-1} x + \cos^{-1} y)$
66. $\cos(\sin^{-1} x - \cos^{-1} y)$
67. $\sin(\sin^{-1} 0.6032 + \cos^{-1} 0.4621)$
68. $\cos(\sin^{-1} 0.7325 - \cos^{-1} 0.4838)$

Skill Maintenance

In each of Exercises 69–76, fill in the blank with the correct term. Some of the given choices will not be used.

- | | |
|---------------------|----------------|
| linear speed | congruent |
| angular speed | circular |
| angle of elevation | periodic |
| angle of depression | period |
| complementary | amplitude |
| supplementary | quadrantal |
| similar | radian measure |
69. A function f is said to be _____ if there exists a positive constant p such that $f(s+p) = f(s)$ for all s in the domain of f .
70. The _____ of a rotation is the ratio of the distance s traveled by a point at a radius r from the center of rotation to the length of the radius r .

71. Triangles are _____ if their corresponding angles have the same measure.
72. The angle between the horizontal and a line of sight below the horizontal is called a(n) _____.
73. _____ is the amount of rotation per unit of time.
74. Two positive angles are _____ if their sum is 180° .
75. The _____ of a periodic function is one half of the distance between its maximum and minimum function values.
76. Trigonometric functions with domains composed of real numbers are called _____ functions.

Synthesis

Prove the identity.

$$77. \sin^{-1} x + \cos^{-1} x = \frac{\pi}{2}$$

$$78. \tan^{-1} x + \cot^{-1} x = \frac{\pi}{2}$$

$$79. \sin^{-1} x = \tan^{-1} \frac{x}{\sqrt{1-x^2}}$$

$$80. \tan^{-1} x = \sin^{-1} \frac{x}{\sqrt{x^2+1}}$$

$$81. \sin^{-1} x = \cos^{-1} \sqrt{1-x^2}, \quad \text{for } x \geq 0$$

$$82. \cos^{-1} x = \tan^{-1} \frac{\sqrt{1-x^2}}{x}, \quad \text{for } x > 0$$

83. **Height of a Mural.** An art student's eye is at a point A, looking at a mural of height h , with the bottom of the mural y feet above the eye (see the figure). The eye is x feet from the wall. Write an expression for θ in terms of x , y , and h . Then evaluate the expression when $x = 20$ ft, $y = 7$ ft, and $h = 25$ ft.

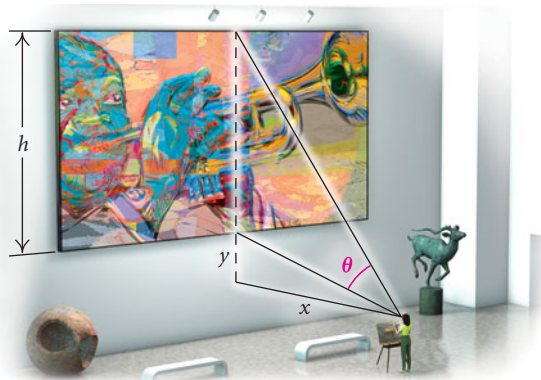

84. Use a calculator to approximate the following expression:

$$16 \tan^{-1} \frac{1}{5} - 4 \tan^{-1} \frac{1}{239}$$

What number does this expression seem to approximate?

Solving Trigonometric Equations

7.5

► Solve trigonometric equations.

When an equation contains a trigonometric expression with a variable, such as $\cos x$, it is called a trigonometric equation. Some trigonometric equations are identities, such as $\sin^2 x + \cos^2 x = 1$. Now we consider equations, such as $2 \cos x = -1$, that are usually not identities. As we have done for other types of equations, we will solve such equations by finding all values for x that make the equation true.

EXAMPLE 1 Solve: $2 \cos x = -1$.**Algebraic Solution**

We first solve for $\cos x$:

$$\begin{aligned} 2 \cos x &= -1 \\ \cos x &= -\frac{1}{2}. \end{aligned}$$

The solutions are numbers that have a cosine of $-\frac{1}{2}$. To find them, we use the unit circle (see Section 6.5).

There are just two points on the unit circle for which the cosine is $-\frac{1}{2}$, as shown in the following figure.

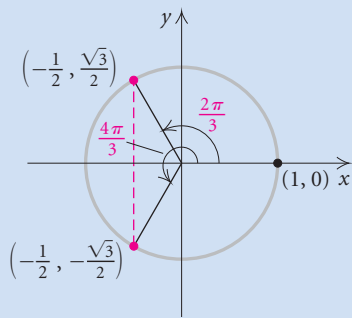

They are the points corresponding to $2\pi/3$ and $4\pi/3$. These numbers, plus any multiple of 2π , are the solutions:

$$\frac{2\pi}{3} + 2k\pi \quad \text{and} \quad \frac{4\pi}{3} + 2k\pi,$$

where k is any integer. In degrees, the solutions are

$$120^\circ + k \cdot 360^\circ \quad \text{and} \quad 240^\circ + k \cdot 360^\circ,$$

where k is any integer.

Visualizing the Solution

We graph $y = 2 \cos x$ and $y = -1$. The first coordinates of the points of intersection of the graphs are the values of x for which $2 \cos x = -1$.

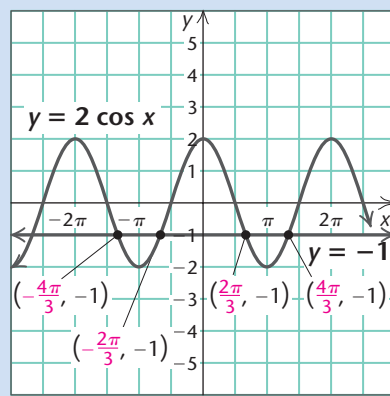

The only solutions in $[-2\pi, 2\pi]$ are

$$-\frac{4\pi}{3}, \quad -\frac{2\pi}{3}, \quad \frac{2\pi}{3}, \quad \text{and} \quad \frac{4\pi}{3}.$$

Since the cosine is periodic, there is an infinite number of solutions. Thus the entire set of solutions is

$$\frac{2\pi}{3} + 2k\pi \quad \text{and} \quad \frac{4\pi}{3} + 2k\pi,$$

where k is any integer.

Now Try Exercise 1.

EXAMPLE 2 Solve: $4 \sin^2 x = 1$.**Algebraic Solution**

We begin by solving for $\sin x$:

$$4 \sin^2 x = 1$$

$$\sin^2 x = \frac{1}{4}$$

$$\sin x = \pm \frac{1}{2}.$$

Again, we use the unit circle to find those numbers having a sine of $\frac{1}{2}$ or $-\frac{1}{2}$.

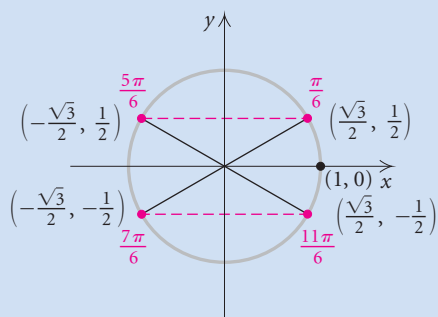

The solutions are

$$\frac{\pi}{6} + 2k\pi, \quad \frac{5\pi}{6} + 2k\pi, \quad \frac{7\pi}{6} + 2k\pi,$$

and

$$\frac{11\pi}{6} + 2k\pi,$$

where k is any integer. In degrees, the solutions are

$$30^\circ + k \cdot 360^\circ, \quad 150^\circ + k \cdot 360^\circ, \\ 210^\circ + k \cdot 360^\circ, \quad \text{and} \quad 330^\circ + k \cdot 360^\circ,$$

where k is any integer.

The general solutions listed above could be condensed using odd as well as even multiples of π :

$$\frac{\pi}{6} + k\pi \quad \text{and} \quad \frac{5\pi}{6} + k\pi,$$

or, in degrees,

$$30^\circ + k \cdot 180^\circ \quad \text{and} \quad 150^\circ + k \cdot 180^\circ,$$

where k is any integer.

Visualizing the Solution

From the graph shown here, we see that the first coordinates of the points of intersection of the graphs of

$$y = 4 \sin^2 x \quad \text{and} \quad y = 1$$

in $[0, 2\pi)$ are

$$\frac{\pi}{6}, \quad \frac{5\pi}{6}, \quad \frac{7\pi}{6}, \quad \text{and} \quad \frac{11\pi}{6}.$$

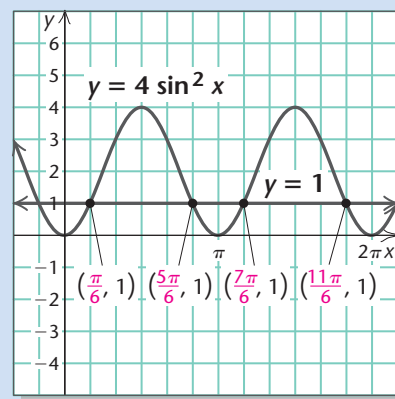

Thus, since the sine function is periodic, the general solutions are

$$\frac{\pi}{6} + k\pi \quad \text{and} \quad \frac{5\pi}{6} + k\pi,$$

or, in degrees,

$$30^\circ + k \cdot 180^\circ \quad \text{and} \quad 150^\circ + k \cdot 180^\circ,$$

where k is any integer.

In most applications, it is sufficient to find just the solutions from 0 to 2π or from 0° to 360° . We then remember that any multiple of 2π , or 360° , can be added to obtain the rest of the solutions.

We must be careful to find all solutions in the interval $[0, 2\pi)$ when solving trigonometric equations involving double angles.

EXAMPLE 3 Solve $3 \tan 2x = -3$ in the interval $[0, 2\pi)$.

Solution We first solve for $\tan 2x$:

$$3 \tan 2x = -3$$

$$\tan 2x = -1.$$

We are looking for solutions x to the equation for which

$$0 \leq x < 2\pi.$$

Multiplying by 2, we get

$$0 \leq 2x < 4\pi,$$

which is the interval we use when solving $\tan 2x = -1$.

Using the unit circle, we find points $2x$ in $[0, 4\pi)$ for which $\tan 2x = -1$. These values of $2x$ are as follows:

$$2x = \frac{3\pi}{4}, \quad \frac{7\pi}{4}, \quad \frac{11\pi}{4}, \quad \text{and} \quad \frac{15\pi}{4}.$$

Thus the desired values of x in $[0, 2\pi)$ are each of these values divided by 2. Therefore,

$$x = \frac{3\pi}{8}, \quad \frac{7\pi}{8}, \quad \frac{11\pi}{8}, \quad \text{and} \quad \frac{15\pi}{8}.$$

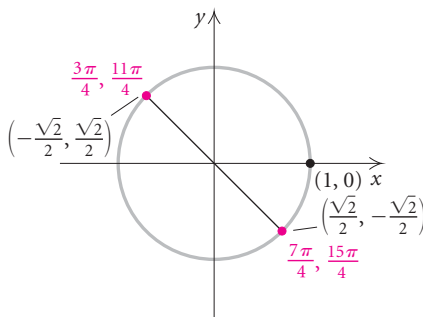

Now Try Exercise 21.

Calculators are needed to solve some trigonometric equations. Answers can be found in radians or degrees, depending on the mode setting.

EXAMPLE 4 Solve $\frac{1}{2} \cos \phi + 1 = 1.2108$ in the interval $[0, 360^\circ)$.

Solution We have

$$\frac{1}{2} \cos \phi + 1 = 1.2108$$

$$\frac{1}{2} \cos \phi = 0.2108$$

$$\cos \phi = 0.4216.$$

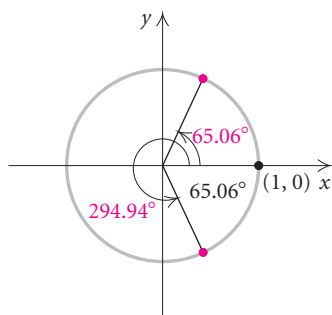

Using a calculator set in DEGREE mode, we find that the reference angle, $\cos^{-1} 0.4216$, is

$$\phi \approx 65.06^\circ.$$

Since $\cos \phi$ is positive, the solutions are in quadrants I and IV. The solutions in $[0, 360^\circ)$ are

$$65.06^\circ \quad \text{and} \quad 360^\circ - 65.06^\circ = 294.94^\circ.$$

➔ Now Try Exercise 9.

EXAMPLE 5 Solve $2 \cos^2 u = 1 - \cos u$ in the interval $[0^\circ, 360^\circ)$.

Algebraic Solution

We use the principle of zero products:

$$2 \cos^2 u = 1 - \cos u$$

$$2 \cos^2 u + \cos u - 1 = 0$$

$$(2 \cos u - 1)(\cos u + 1) = 0$$

$$2 \cos u - 1 = 0 \quad \text{or} \quad \cos u + 1 = 0$$

$$2 \cos u = 1 \quad \text{or} \quad \cos u = -1$$

$$\cos u = \frac{1}{2} \quad \text{or} \quad \cos u = -1.$$

Thus,

$$u = 60^\circ, 300^\circ \quad \text{or} \quad u = 180^\circ.$$

The solutions in $[0^\circ, 360^\circ)$ are 60° , 180° , and 300° .

Visualizing the Solution

The solutions of the equation are the zeros of the function

$$y = 2 \cos^2 u + \cos u - 1.$$

Note that they are also the first coordinates of the x -intercepts of the graph.

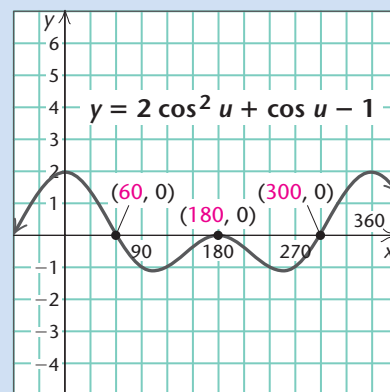

The zeros in $[0^\circ, 360^\circ)$ are 60° , 180° , and 300° . Thus the solutions of the equation in $[0^\circ, 360^\circ)$ are 60° , 180° , and 300° .

➔ Now Try Exercise 15.

TECHNOLOGY CONNECTION

We can use either the Intersect method or the Zero method to solve trigonometric equations. Here we illustrate by solving the equation in Example 5 using both methods.

Intersect Method. We graph the equations

$$y_1 = 2 \cos^2 x \quad \text{and} \quad y_2 = 1 - \cos x$$

and use the INTERSECT feature to find the first coordinates of the points of intersection.

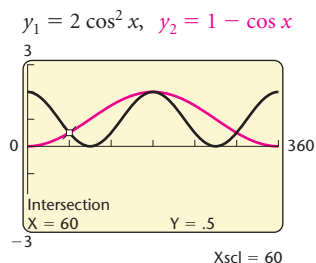

The leftmost solution is 60° . Using the INTERSECT feature two more times, we find the other solutions, 180° and 300° .

Zero Method. We write the equation in the form

$$2 \cos^2 u + \cos u - 1 = 0.$$

Then we graph

$$y = 2 \cos^2 x + \cos x - 1$$

and use the ZERO feature to determine the zeros of the function.

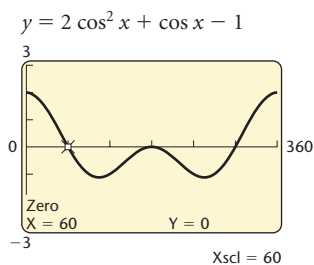

The leftmost zero is 60° . Using the ZERO feature two more times, we find the other zeros, 180° and 300° . The solutions in $[0^\circ, 360^\circ)$ are 60° , 180° , and 300° .

EXAMPLE 6 Solve $\sin^2 \beta - \sin \beta = 0$ in the interval $[0, 2\pi)$.

Algebraic Solution

We factor and use the principle of zero products:

$$\sin^2 \beta - \sin \beta = 0$$

$$\sin \beta (\sin \beta - 1) = 0 \quad \text{Factoring}$$

$$\sin \beta = 0 \quad \text{or} \quad \sin \beta - 1 = 0$$

$$\sin \beta = 0 \quad \text{or} \quad \sin \beta = 1$$

$$\beta = 0, \pi \quad \text{or} \quad \beta = \frac{\pi}{2}.$$

The solutions in $[0, 2\pi)$ are $0, \pi/2$, and π .



Visualizing the Solution

The solutions of the equation

$$\sin^2 \beta - \sin \beta = 0$$

are the zeros of the function

$$f(\beta) = \sin^2 \beta - \sin \beta.$$

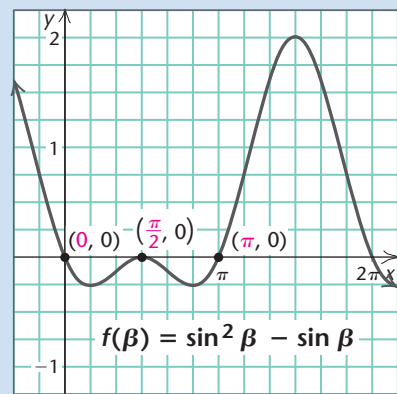

The zeros in $[0, 2\pi)$ are $0, \pi/2$, and π .
Thus the solutions of $\sin^2 \beta - \sin \beta = 0$ are $0, \pi/2$, and π .

 **Now Try Exercise 17.**

If a trigonometric equation is quadratic but difficult or impossible to factor, we use the *quadratic formula*.

EXAMPLE 7 Solve $10 \sin^2 x - 12 \sin x - 7 = 0$ in the interval $[0^\circ, 360^\circ)$.

Solution This equation is quadratic in $\sin x$ with $a = 10$, $b = -12$, and $c = -7$. Substituting into the quadratic formula, we get

$$\begin{aligned}\sin x &= \frac{-b \pm \sqrt{b^2 - 4ac}}{2a} && \text{Using the quadratic formula} \\ &= \frac{-(-12) \pm \sqrt{(-12)^2 - 4(10)(-7)}}{2 \cdot 10} && \text{Substituting} \\ &= \frac{12 \pm \sqrt{144 + 280}}{20} = \frac{12 \pm \sqrt{424}}{20} \\ &\approx \frac{12 \pm 20.5913}{20}\end{aligned}$$

$$\sin x \approx 1.6296 \quad \text{or} \quad \sin x \approx -0.4296.$$

Since sine values are never greater than 1, the first of the equations has no solution. Using the other equation, we find the reference angle to be 25.44° . Since $\sin x$ is negative, the solutions are in quadrants III and IV.

Thus the solutions in $[0^\circ, 360^\circ)$ are

$$180^\circ + 25.44^\circ = 205.44^\circ \quad \text{and} \quad 360^\circ - 25.44^\circ = 334.56^\circ.$$

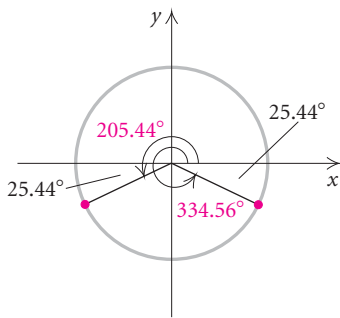

Now Try Exercise 23.

Trigonometric equations can involve more than one function.

EXAMPLE 8 Solve $2 \cos^2 x \tan x = \tan x$ in the interval $[0, 2\pi)$.

Solution We have

$$\begin{aligned}2 \cos^2 x \tan x &= \tan x \\ 2 \cos^2 x \tan x - \tan x &= 0 \\ \tan x (2 \cos^2 x - 1) &= 0 \\ \tan x = 0 &\quad \text{or} \quad 2 \cos^2 x - 1 = 0 \\ \cos^2 x &= \frac{1}{2} \\ \cos x &= \pm \frac{\sqrt{2}}{2} \\ x = 0, \pi &\quad \text{or} \quad x = \frac{\pi}{4}, \frac{3\pi}{4}, \frac{5\pi}{4}, \frac{7\pi}{4}.\end{aligned}$$

Thus, $x = 0, \pi/4, 3\pi/4, \pi, 5\pi/4,$ and $7\pi/4$.

Now Try Exercise 29.

TECHNOLOGY CONNECTION

In Example 9, we can graph the left side and then the right side of the equation as seen in the first window below. Then we look for points of intersection. We could also rewrite the equation as $\sin x + \cos x - 1 = 0$, graph the left side, and look for the zeros of the function, as illustrated in the second window below. In each window, we see the solutions in $[0, 2\pi)$ as 0 and $\pi/2$.

This example illustrates a valuable advantage of the calculator—that is, with a graphing calculator, extraneous solutions do not appear.

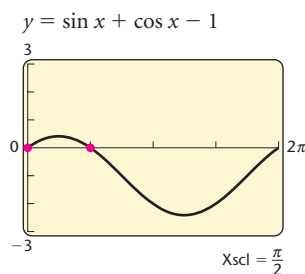
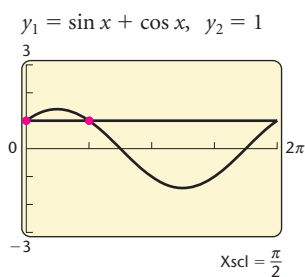

When a trigonometric equation involves more than one function, it is sometimes helpful to use identities to rewrite the equation in terms of a single function.

EXAMPLE 9 Solve $\sin x + \cos x = 1$ in the interval $[0, 2\pi)$.

Solution We have

$$\sin x + \cos x = 1$$

$$(\sin x + \cos x)^2 = 1^2 \quad \text{Squaring both sides}$$

$$\sin^2 x + 2 \sin x \cos x + \cos^2 x = 1$$

$$2 \sin x \cos x + 1 = 1 \quad \text{Using } \sin^2 x + \cos^2 x = 1$$

$$2 \sin x \cos x = 0$$

$$\sin 2x = 0. \quad \text{Using } 2 \sin x \cos x = \sin 2x$$

We are looking for solutions x to the equation for which $0 \leq x < 2\pi$. Multiplying by 2, we get $0 \leq 2x < 4\pi$, which is the interval we consider to solve $\sin 2x = 0$. These values of $2x$ are $0, \pi, 2\pi$, and 3π . Thus the desired values of x in $[0, 2\pi)$ satisfying this equation are $0, \pi/2, \pi$, and $3\pi/2$. Now we check these in the original equation $\sin x + \cos x = 1$:

$$\sin 0 + \cos 0 = 0 + 1 = 1,$$

$$\sin \frac{\pi}{2} + \cos \frac{\pi}{2} = 1 + 0 = 1,$$

$$\sin \pi + \cos \pi = 0 + (-1) = -1,$$

$$\sin \frac{3\pi}{2} + \cos \frac{3\pi}{2} = (-1) + 0 = -1.$$

We find that π and $3\pi/2$ do not check, but the other values do. Thus the solutions in $[0, 2\pi)$ are

$$0 \quad \text{and} \quad \frac{\pi}{2}.$$

When the solution process involves squaring both sides, values are sometimes obtained that are not solutions of the original equation. As we saw in this example, it is important to check the possible solutions.

Now Try Exercise 39.

EXAMPLE 10 Solve $\cos 2x + \sin x = 1$ in the interval $[0, 2\pi)$.

Algebraic Solution

We have

$$\cos 2x + \sin x = 1$$

$$1 - 2\sin^2 x + \sin x = 1$$

Using the identity
 $\cos 2x = 1 - 2\sin^2 x$

$$-2\sin^2 x + \sin x = 0$$

$$\sin x(-2\sin x + 1) = 0$$

Factoring

$$\sin x = 0 \quad \text{or} \quad -2\sin x + 1 = 0$$

Principle of
zero products

$$\sin x = 0 \quad \text{or} \quad \sin x = \frac{1}{2}$$

$$x = 0, \pi \quad \text{or} \quad x = \frac{\pi}{6}, \frac{5\pi}{6}$$

All four values check. The solutions in $[0, 2\pi)$ are $0, \pi/6, 5\pi/6,$ and π .

Visualizing the Solution

We graph the function $y = \cos 2x + \sin x - 1$ and look for the zeros of the function.

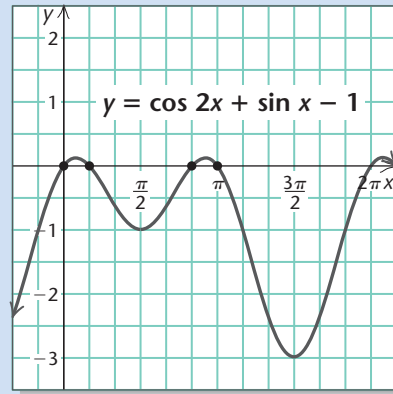

The zeros, or solutions, in $[0, 2\pi)$ are $0, \pi/6, 5\pi/6,$ and π .

STUDY TIP

Check your solutions to the odd-numbered exercises in the exercise sets with the step-by-step annotated solutions in the *Student's Solutions Manual*. If you are still having difficulty with the concepts of this section, make time to view the content videos that correspond to the examples.

EXAMPLE 11 Solve $\tan^2 x + \sec x - 1 = 0$ in the interval $[0, 2\pi)$.

Solution We have

$$\tan^2 x + \sec x - 1 = 0$$

$$\sec^2 x - 1 + \sec x - 1 = 0$$

Using the identity
 $1 + \tan^2 x = \sec^2 x$, or
 $\tan^2 x = \sec^2 x - 1$

$$\sec^2 x + \sec x - 2 = 0$$

$$(\sec x + 2)(\sec x - 1) = 0$$

Factoring

$$\sec x = -2 \quad \text{or} \quad \sec x = 1$$

Principle of zero
products

$$\cos x = -\frac{1}{2} \quad \text{or} \quad \cos x = 1$$

Using the identity
 $\cos x = 1/\sec x$

$$x = \frac{2\pi}{3}, \frac{4\pi}{3} \quad \text{or} \quad x = 0$$

All these values check. The solutions in $[0, 2\pi)$ are $0, 2\pi/3,$ and $4\pi/3$.

➔ Now Try Exercise 27.

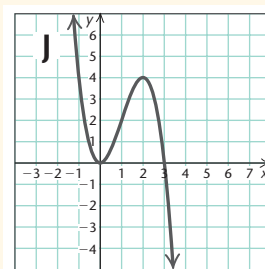
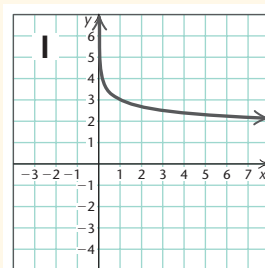
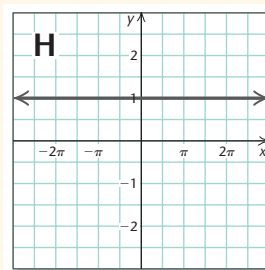
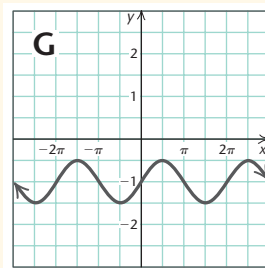
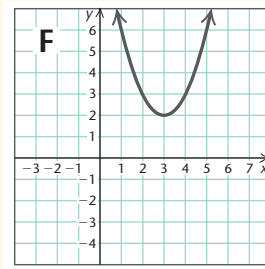
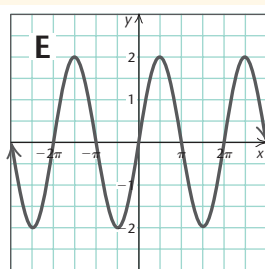
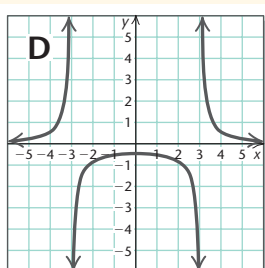
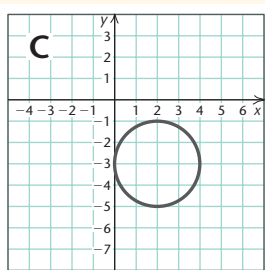
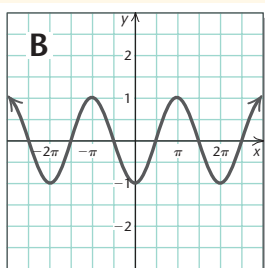
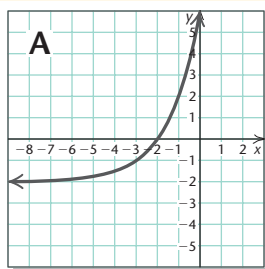

Visualizing the Graph

Match the equation with its graph.

1. $f(x) = \frac{4}{x^2 - 9}$

2. $f(x) = \frac{1}{2} \sin x - 1$

3. $(x - 2)^2 + (y + 3)^2 = 4$

4. $y = \sin^2 x + \cos^2 x$

5. $f(x) = 3 - \log x$

6. $f(x) = 2^{x+3} - 2$

7. $y = 2 \cos\left(x - \frac{\pi}{2}\right)$

8. $y = -x^3 + 3x^2$

9. $f(x) = (x - 3)^2 + 2$

10. $f(x) = -\cos x$

Answers on page A-48

7.5 Exercise Set

Solve, finding all solutions. Express the solutions in both radians and degrees.

1. $\cos x = \frac{\sqrt{3}}{2}$

2. $\sin x = -\frac{\sqrt{2}}{2}$

3. $\tan x = -\sqrt{3}$

4. $\cos x = -\frac{1}{2}$

5. $\sin x = \frac{1}{2}$

6. $\tan x = -1$

7. $\cos x = -\frac{\sqrt{2}}{2}$

8. $\sin x = \frac{\sqrt{3}}{2}$

Solve, finding all solutions in $[0, 2\pi)$ or $[0^\circ, 360^\circ)$.

9. $2 \cos x - 1 = -1.2814$

10. $\sin x + 3 = 2.0816$

11. $2 \sin x + \sqrt{3} = 0$

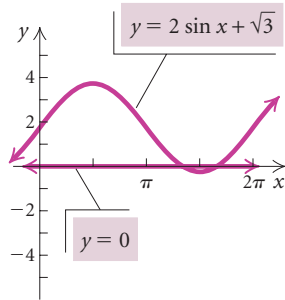

12. $2 \tan x - 4 = 1$

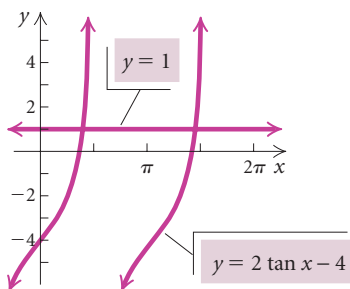

13. $2 \cos^2 x = 1$

14. $\csc^2 x - 4 = 0$

15. $2 \sin^2 x + \sin x = 1$

16. $\cos^2 x + 2 \cos x = 3$

17. $2 \cos^2 x - \sqrt{3} \cos x = 0$

18. $2 \sin^2 \theta + 7 \sin \theta = 4$

19. $6 \cos^2 \phi + 5 \cos \phi + 1 = 0$

20. $2 \sin t \cos t + 2 \sin t - \cos t - 1 = 0$

21. $\sin 2x \cos x - \sin x = 0$

22. $5 \sin^2 x - 8 \sin x = 3$

23. $\cos^2 x + 6 \cos x + 4 = 0$

24. $2 \tan^2 x = 3 \tan x + 7$

25. $7 = \cot^2 x + 4 \cot x$

26. $3 \sin^2 x = 3 \sin x + 2$

Solve, finding all solutions in $[0, 2\pi)$.

27. $\cos 2x - \sin x = 1$

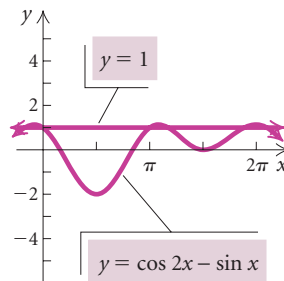

28. $2 \sin x \cos x + \sin x = 0$

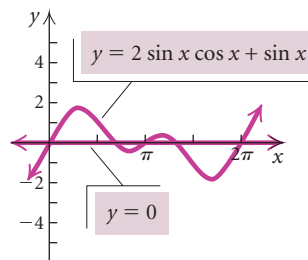

29. $\tan x \sin x - \tan x = 0$

30. $\sin 4x - 2 \sin 2x = 0$

31. $\sin 2x \cos x + \sin x = 0$

32. $\cos 2x \sin x + \sin x = 0$

33. $2 \sec x \tan x + 2 \sec x + \tan x + 1 = 0$

34. $\sin 2x \sin x - \cos 2x \cos x = -\cos x$

35. $\sin 2x + \sin x + 2 \cos x + 1 = 0$

36. $\tan^2 x + 4 = 2 \sec^2 x + \tan x$

37. $\sec^2 x - 2 \tan^2 x = 0$

38. $\cot x = \tan(2x - 3\pi)$

39. $2 \cos x + 2 \sin x = \sqrt{6}$

40. $\sqrt{3} \cos x - \sin x = 1$

41. $\sec^2 x + 2 \tan x = 6$

42. $5 \cos 2x + \sin x = 4$

43. $\cos(\pi - x) + \sin\left(x - \frac{\pi}{2}\right) = 1$

44. $\frac{\sin^2 x - 1}{\cos\left(\frac{\pi}{2} - x\right) + 1} = \frac{\sqrt{2}}{2} - 1$

45. **Daylight Hours.** The number of daylight hours in Kajaani, Finland, varies from approximately 4.3 hr on December 21 to 20.7 on June 11.

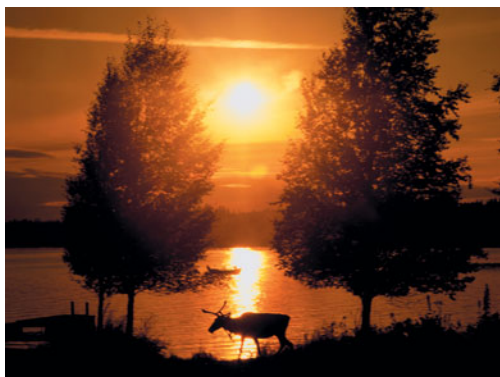

The following sine function can be used to approximate the number of daylight hours, y , in Kajaani for day x :

$$y = 7.8787 \sin(0.0166x - 1.2723) + 12.1840.$$

- a) Approximate the number of daylight hours in Kajaani for April 5 ($x = 95$), for August 18 ($x = 230$), and for November 29 ($x = 333$). (Hint: Set the calculator in radian mode.)
- b) Determine on which days of the year there will be about 12 hr of daylight.

46. **Sales of Skis.** Sales of certain products fluctuate in cycles. The following sine function can be used to estimate the total amount of sales of skis, y , in thousands of dollars, in month x , for a business in a northern climate:

$$y = 9.584 \sin(0.436x + 2.097) + 10.558.$$

Approximate the total amount of sales to the nearest dollar for December and for July. (Hint: Set the calculator in radian mode.)



Skill Maintenance

Solve the right triangle.

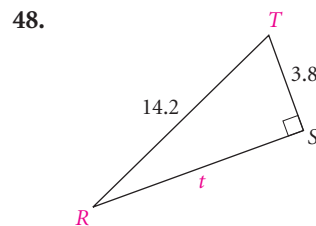
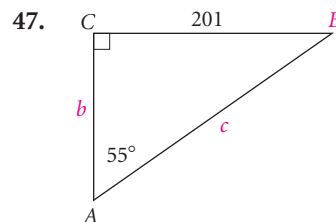

Solve.

49. $\frac{x}{27} = \frac{4}{3}$

50. $\frac{0.01}{0.7} = \frac{0.2}{h}$

Synthesis

Solve in $[0, 2\pi)$.

$$51. |\sin x| = \frac{\sqrt{3}}{2}$$

$$52. |\cos x| = \frac{1}{2}$$

$$53. \sqrt{\tan x} = \sqrt[4]{3}$$

$$54. 12 \sin x - 7 \sqrt{\sin x} + 1 = 0$$

$$55. \ln(\cos x) = 0$$

$$56. e^{\sin x} = 1$$

$$57. \sin(\ln x) = -1$$

$$58. e^{\ln(\sin x)} = 1$$

59. **Temperature During an Illness.** The temperature T , in degrees Fahrenheit, of a patient t days into a 12-day illness is given by

$$T(t) = 101.6^\circ + 3^\circ \sin\left(\frac{\pi}{8}t\right).$$

Find the times t during the illness at which the patient's temperature was 103° .

60. **Satellite Location.** A satellite circles the earth in such a manner that it is y miles from the equator (north or south, height from the surface not considered) t minutes after its launch, where

$$y = 5000 \left[\cos \frac{\pi}{45}(t - 10) \right].$$

At what times t in the interval $[0, 240]$, the first 4 hr, is the satellite 3000 mi north of the equator?

61. **Nautical Mile.** (See Exercise 54 in Exercise Set 7.2.) In Great Britain, the *nautical mile* is defined as the length of a minute of arc of the earth's radius. Since the earth is flattened at the poles, a British nautical mile varies with latitude. In fact, it is given, in feet, by the function

$$N(\phi) = 6066 - 31 \cos 2\phi,$$

where ϕ is the latitude in degrees. At what latitude north is the length of a British nautical mile found to be 6040 ft?

62. **Acceleration Due to Gravity.** (See Exercise 55 in Exercise Set 7.2.) The acceleration due to gravity is often denoted by g in a formula such as $S = \frac{1}{2}gt^2$, where S is the distance that an object falls in t seconds. The number g is generally considered constant, but in fact it varies slightly with latitude. If ϕ stands for latitude, in degrees, an excellent approximation of g is given by the formula
- $$g = 9.78049(1 + 0.005288 \sin^2 \phi - 0.000006 \sin^2 2\phi),$$
- where g is measured in meters per second per second at sea level. At what latitude north does $g = 9.8$?

Solve.

$$63. \cos^{-1} x = \cos^{-1} \frac{3}{5} - \sin^{-1} \frac{4}{5}$$

$$64. \sin^{-1} x = \tan^{-1} \frac{1}{3} + \tan^{-1} \frac{1}{2}$$

65. Suppose that $\sin x = 5 \cos x$. Find $\sin x \cos x$.

Chapter 7 Summary and Review

STUDY GUIDE

KEY TERMS AND CONCEPTS

Identity

An **identity** is an equation that is true for all possible replacements.

Basic Identities

$$\sin x = \frac{1}{\csc x}, \quad \tan x = \frac{\sin x}{\cos x},$$

$$\cos x = \frac{1}{\sec x}, \quad \cot x = \frac{\cos x}{\sin x},$$

$$\tan x = \frac{1}{\cot x},$$

$$\sin(-x) = -\sin x,$$

$$\cos(-x) = \cos x,$$

$$\tan(-x) = -\tan x$$

Pythagorean Identities

$$\sin^2 x + \cos^2 x = 1,$$

$$1 + \cot^2 x = \csc^2 x,$$

$$1 + \tan^2 x = \sec^2 x$$

Sum and Difference Identities

$$\sin(u \pm v) = \sin u \cos v \pm \cos u \sin v,$$

$$\cos(u \pm v) = \cos u \cos v \mp \sin u \sin v,$$

$$\tan(u \pm v) = \frac{\tan u \pm \tan v}{1 \mp \tan u \tan v}$$

EXAMPLES

SECTION 7.1: IDENTITIES: PYTHAGOREAN AND SUM AND DIFFERENCE

Simplify.

$$\text{a) } \frac{\tan^2 x \sec x}{\sec^2 x \tan x}$$

$$\text{b) } \frac{\cos^2 \alpha - 2 \cos \alpha - 15}{\cos \alpha + 3}$$

$$\text{c) } \frac{\cos \theta}{\sin(-\theta)} + \frac{1}{\tan \theta}$$

$$\text{d) } \sqrt{\frac{1 + \sin x}{1 - \sin x}}$$

$$\text{a) } \frac{\tan^2 x \sec x}{\sec^2 x \tan x} = \frac{\tan x}{\sec x} = \frac{\sin x}{\cos x} \cdot \frac{\cos x}{1} = \sin x$$

$$\text{b) } \frac{\cos^2 \alpha - 2 \cos \alpha - 15}{\cos \alpha + 3} = \frac{(\cos \alpha - 5)(\cos \alpha + 3)}{\cos \alpha + 3} = \cos \alpha - 5$$

$$\text{c) } \frac{\cos \theta}{\sin(-\theta)} + \frac{1}{\tan \theta} = -\frac{\cos \theta}{\sin \theta} + \frac{\cos \theta}{\sin \theta} = 0$$

$$\begin{aligned} \text{d) } \sqrt{\frac{1 + \sin x}{1 - \sin x}} &= \sqrt{\frac{1 + \sin x}{1 - \sin x}} \cdot \sqrt{\frac{1 + \sin x}{1 + \sin x}} = \frac{\sqrt{1 - \sin^2 x}}{1 - \sin x} \\ &= \frac{\sqrt{\cos^2 x}}{1 - \sin x} = \frac{\cos x}{1 - \sin x} \end{aligned}$$

Evaluate $\cos \frac{7\pi}{12}$ exactly.

$$\begin{aligned} \cos \frac{7\pi}{12} &= \cos \left(\frac{3\pi}{4} - \frac{\pi}{6} \right) = \cos \frac{3\pi}{4} \cos \frac{\pi}{6} + \sin \frac{3\pi}{4} \sin \frac{\pi}{6} \\ &= \left(-\frac{\sqrt{2}}{2} \right) \left(\frac{\sqrt{3}}{2} \right) + \left(\frac{\sqrt{2}}{2} \right) \left(\frac{1}{2} \right) = \frac{\sqrt{2} - \sqrt{6}}{4} \end{aligned}$$

Write $\sin 51^\circ \cos 24^\circ - \cos 51^\circ \sin 24^\circ$ as a trigonometric function of a single angle. Then evaluate.

We use the identity

$$\sin(u - v) = \sin u \cos v - \cos u \sin v.$$

Then

$$\begin{aligned} \sin 51^\circ \cos 24^\circ - \cos 51^\circ \sin 24^\circ &= \sin(51^\circ - 24^\circ) \\ &= \sin 27^\circ \approx 0.4540. \end{aligned}$$

Assume that $\sin \alpha = \frac{7}{8}$ and $\sin \beta = \frac{9}{10}$ and that α and β are between 0 and $\pi/2$. Then evaluate $\sin(\alpha + \beta)$.

We use the identity

$$\sin(\alpha + \beta) = \sin \alpha \cos \beta + \cos \alpha \sin \beta.$$

(Continued)

Substituting, we have

$$\sin(\alpha + \beta) = \frac{7}{8} \cos \beta + \frac{9}{10} \cos \alpha.$$

To determine $\cos \alpha$ and $\cos \beta$, we use reference triangles and the Pythagorean theorem.

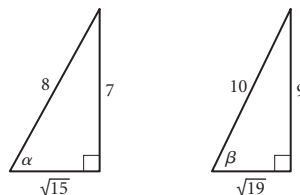

$$\cos \alpha = \frac{\sqrt{15}}{8} \quad \text{and} \quad \cos \beta = \frac{\sqrt{19}}{10}$$

Then

$$\sin(\alpha + \beta) = \frac{7}{8} \cdot \frac{\sqrt{19}}{10} + \frac{9}{10} \cdot \frac{\sqrt{15}}{8} = \frac{7\sqrt{19} + 9\sqrt{15}}{80}.$$

SECTION 7.2: IDENTITIES: COFUNCTION, DOUBLE-ANGLE, AND HALF-ANGLE

Cofunction Identities

$$\sin\left(\frac{\pi}{2} - x\right) = \cos x, \quad \cos\left(\frac{\pi}{2} - x\right) = \sin x,$$

$$\tan\left(\frac{\pi}{2} - x\right) = \cot x, \quad \cot\left(\frac{\pi}{2} - x\right) = \tan x,$$

$$\sec\left(\frac{\pi}{2} - x\right) = \csc x, \quad \csc\left(\frac{\pi}{2} - x\right) = \sec x,$$

$$\sin\left(x \pm \frac{\pi}{2}\right) = \pm \cos x,$$

$$\cos\left(x \pm \frac{\pi}{2}\right) = \mp \sin x$$

Double-Angle Identities

$$\sin 2x = 2 \sin x \cos x,$$

$$\cos 2x = \cos^2 x - \sin^2 x$$

$$= 1 - 2 \sin^2 x$$

$$= 2 \cos^2 x - 1,$$

$$\tan 2x = \frac{2 \tan x}{1 - \tan^2 x}$$

Given that $\cos \theta = \frac{3}{5}$ and that the terminal side of θ is in quadrant IV,

find the exact function value for $\cos\left(\frac{\pi}{2} - \theta\right)$ and $\cos\left(\theta + \frac{\pi}{2}\right)$.

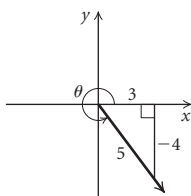

$$\cos\left(\frac{\pi}{2} - \theta\right) = \sin \theta = -\frac{4}{5};$$

$$\cos\left(\theta + \frac{\pi}{2}\right) = -\sin \theta = -\left(-\frac{4}{5}\right) = \frac{4}{5}$$

Given that $\tan \theta = -3$ and that θ is in quadrant II, find $\sin 2\theta$, $\cos 2\theta$, and the quadrant in which 2θ lies.

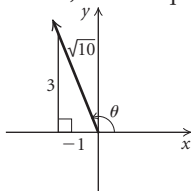

$$\sin \theta = \frac{3}{\sqrt{10}};$$

$$\cos \theta = -\frac{1}{\sqrt{10}};$$

$$\sin 2\theta = 2 \sin \theta \cos \theta = 2 \cdot \frac{3}{\sqrt{10}} \cdot \left(-\frac{1}{\sqrt{10}}\right)$$

$$= -\frac{6}{10} = -\frac{3}{5};$$

$$\cos 2\theta = \cos^2 \theta - \sin^2 \theta = \left(-\frac{1}{\sqrt{10}}\right)^2 - \left(\frac{3}{\sqrt{10}}\right)^2$$

$$= \frac{1}{10} - \frac{9}{10} = -\frac{8}{10} = -\frac{4}{5}$$

Since both $\sin 2\theta$ and $\cos 2\theta$ are negative, we have 2θ in quadrant III.

Half-Angle Identities

$$\begin{aligned}\sin \frac{x}{2} &= \pm \sqrt{\frac{1 - \cos x}{2}}, \\ \cos \frac{x}{2} &= \pm \sqrt{\frac{1 + \cos x}{2}}, \\ \tan \frac{x}{2} &= \pm \sqrt{\frac{1 - \cos x}{1 + \cos x}} \\ &= \frac{\sin x}{1 + \cos x} \\ &= \frac{1 - \cos x}{\sin x}\end{aligned}$$

Simplify: $\frac{\frac{1}{2} \sin 2x}{1 - \cos^2 x}$.

$$\frac{\frac{1}{2} \sin 2x}{1 - \cos^2 x} = \frac{\frac{1}{2} \cdot 2 \sin x \cos x}{\sin^2 x} = \frac{\cos x}{\sin x} = \cot x$$

Evaluate $\sin \frac{3\pi}{8}$ exactly.

Note that $\frac{3\pi}{8}$ is in quadrant I. Thus $\sin \frac{3\pi}{8}$ is positive.

$$\begin{aligned}\sin \frac{3\pi}{8} &= \frac{3\pi}{4} = \sqrt{\frac{1 - \cos \frac{3\pi}{4}}{2}} = \sqrt{\frac{1 - \left(-\frac{\sqrt{2}}{2}\right)}{2}} \\ &= \sqrt{\frac{2 + \sqrt{2}}{4}} = \frac{\sqrt{2 + \sqrt{2}}}{2}\end{aligned}$$

Simplify: $\sin^2 \frac{x}{2} + \cos x$.

$$\sin^2 \frac{x}{2} + \cos x = \frac{1 - \cos x}{2} + \frac{2 \cos x}{2} = \frac{1 + \cos x}{2}$$

SECTION 7.3: PROVING TRIGONOMETRIC IDENTITIES**Proving Identities**

Method 1: Start with either the left side or the right side of the equation and obtain the other side.

Method 2: Work with each side separately until you obtain the same expression.

Using method 1, prove $\frac{\tan x \sin^2 x}{1 + \cos x} = \tan x - \sin x$.

We begin with the left side and obtain the right side:

$$\begin{aligned}\frac{\tan x \sin^2 x}{1 + \cos x} &= \frac{\tan x (1 - \cos^2 x)}{1 + \cos x} \\ &= \frac{\tan x (1 - \cos x)(1 + \cos x)}{(1 + \cos x)} \\ &= \tan x (1 - \cos x) \\ &= \tan x - \tan x \cos x \\ &= \tan x - \sin x.\end{aligned}$$

Using method 2, prove $\frac{\sec \alpha}{1 + \cot^2 \alpha} = \frac{1 - \cos^2 \alpha}{\cos \alpha}$.

We begin with the left side:

$$\begin{aligned}\frac{\sec \alpha}{1 + \cot^2 \alpha} &= \frac{1}{\cos \alpha} = \frac{1}{\csc^2 \alpha} = \frac{1}{\cos \alpha} \cdot \frac{\sin^2 \alpha}{1} \\ &= \sin \alpha \cdot \frac{\sin \alpha}{\cos \alpha} = \sin \alpha \cdot \tan \alpha.\end{aligned}$$

Next, we work with the right side:

$$\frac{1 - \cos^2 \alpha}{\cos \alpha} = \frac{\sin^2 \alpha}{\cos \alpha} = \sin \alpha \cdot \frac{\sin \alpha}{\cos \alpha} = \sin \alpha \cdot \tan \alpha.$$

We have obtained the same expression from each side, so the proof is complete.

Product-to-Sum Identities

$$\sin x \cdot \sin y = \frac{1}{2} [\cos(x - y) - \cos(x + y)],$$

$$\cos x \cdot \cos y = \frac{1}{2} [\cos(x - y) + \cos(x + y)],$$

$$\sin x \cdot \cos y = \frac{1}{2} [\sin(x + y) + \sin(x - y)],$$

$$\cos x \cdot \sin y = \frac{1}{2} [\sin(x + y) - \sin(x - y)]$$

Sum-to-Product Identities

$$\sin x + \sin y = 2 \sin \frac{x + y}{2} \cos \frac{x - y}{2},$$

$$\sin x - \sin y = 2 \cos \frac{x + y}{2} \sin \frac{x - y}{2},$$

$$\cos y + \cos x = 2 \cos \frac{x + y}{2} \cos \frac{x - y}{2},$$

$$\cos y - \cos x = 2 \sin \frac{x + y}{2} \sin \frac{x - y}{2}$$

Use the product-to-sum or the sum-to-product identities to find an identity for $\cos 3\alpha - \cos \alpha$ and for $3 \sin 2\beta \sin 5\beta$.

Using $\cos y - \cos x = 2 \sin \frac{x + y}{2} \sin \frac{x - y}{2}$, we have

$$\begin{aligned} \cos 3\alpha - \cos \alpha &= 2 \sin \frac{4\alpha}{2} \sin \frac{(-2\alpha)}{2} = -2 \sin 2\alpha \sin \alpha \\ &= -2 (2 \sin \alpha \cos \alpha) (\sin \alpha) = -4 \sin^2 \alpha \cos \alpha. \end{aligned}$$

Using $\sin x \cdot \sin y = \frac{1}{2} [\cos(x - y) - \cos(x + y)]$, we have

$$\begin{aligned} 3 \sin 2\beta \sin 5\beta &= 3 \cdot \frac{1}{2} [\cos(-3\beta) - \cos 7\beta] \\ &= \frac{3}{2} [\cos 3\beta - \cos 7\beta]. \end{aligned}$$

Prove: $\tan \frac{x - y}{2} = \frac{\cos y - \cos x}{\sin x + \sin y}$.

We begin with the right side and obtain the left side:

$$\frac{\cos y - \cos x}{\sin x + \sin y} = \frac{2 \sin \frac{x + y}{2} \sin \frac{x - y}{2}}{2 \sin \frac{x + y}{2} \cos \frac{x - y}{2}} = \frac{\sin \frac{x - y}{2}}{\cos \frac{x - y}{2}} = \tan \frac{x - y}{2}.$$

SECTION 7.4: INVERSES OF THE TRIGONOMETRIC FUNCTIONS**Inverse Trigonometric Functions**

FUNCTION	DOMAIN	RANGE
$y = \sin^{-1} x$	$[-1, 1]$	$\left[-\frac{\pi}{2}, \frac{\pi}{2}\right]$
$y = \cos^{-1} x$	$[-1, 1]$	$[0, \pi]$
$y = \tan^{-1} x$	$(-\infty, \infty)$	$\left(-\frac{\pi}{2}, \frac{\pi}{2}\right)$

The notation $y = \sin^{-1} x$ is equivalent to $y = \arcsin x$. The notation can be read:

- the inverse sine of x ,
- the arcsine of x , or
- the number, or angle, whose sine is x .

Find each of the following function values.

a) $\sin^{-1}\left(-\frac{1}{2}\right)$ b) $\cos^{-1}\left(-\frac{\sqrt{2}}{2}\right)$ c) $\tan^{-1} \sqrt{3}$

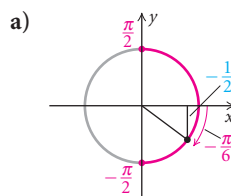

In $[-\pi/2, \pi/2]$, the only number with a sine of $-\frac{1}{2}$ is $-\pi/6$. Thus,
 $\sin^{-1}\left(-\frac{1}{2}\right) = -\pi/6$, or -30° .

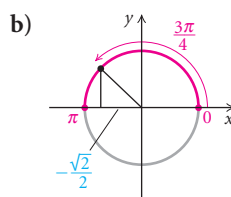

In $[0, \pi]$, the only number with a cosine of $-\frac{\sqrt{2}}{2}$ is $3\pi/4$.
 Thus, $\cos^{-1}\left(-\frac{\sqrt{2}}{2}\right) = 3\pi/4$,
 or 135° .

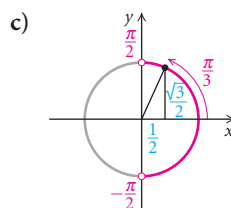

In $(-\pi/2, \pi/2)$, the only number with a tangent of $\sqrt{3}$ is $\pi/3$. Thus,
 $\tan^{-1} \sqrt{3} = \pi/3$, or 60° .

Composition of Trigonometric Functions

The following are true for any x in the domain of the inverse function:

$$\sin(\sin^{-1} x) = x,$$

$$\cos(\cos^{-1} x) = x,$$

$$\tan(\tan^{-1} x) = x.$$

The following are true for any x in the range of the inverse function:

$$\sin^{-1}(\sin x) = x,$$

$$\cos^{-1}(\cos x) = x,$$

$$\tan^{-1}(\tan x) = x.$$

Approximate each of the following function values in both radians and degrees. Round radian measure to four decimal places and degree measure to the nearest tenth of a degree.

a) $\cos^{-1} 0.3281 \approx 1.2365$, or 70.8°

b) $\tan^{-1}(-7.1154) \approx -1.4312$, or -82.0°

c) $\sin^{-1}(-0.5492) \approx -0.5814$, or -33.3°

Simplify each of the following.

a) $\tan(\tan^{-1} \sqrt{3})$

Since $\sqrt{3}$ is in $(-\infty, \infty)$, the domain of \tan^{-1} ,

$$\tan(\tan^{-1} \sqrt{3}) = \sqrt{3}.$$

b) $\cos\left[\cos^{-1}\left(-\frac{1}{2}\right)\right]$

Since $-\frac{1}{2}$ is in $[-1, 1]$, the domain of \cos^{-1} ,

$$\cos\left[\cos^{-1}\left(-\frac{1}{2}\right)\right] = -\frac{1}{2}.$$

c) $\sin^{-1}[\sin(\pi/6)]$

Since $\pi/6$ is in $[-\pi/2, \pi/2]$, the range of \sin^{-1} ,

$$\sin^{-1}[\sin(\pi/6)] = \pi/6.$$

d) $\cos^{-1}[\cos(3\pi/2)]$

Since $3\pi/2$ is not in $[0, \pi]$, the range of \cos^{-1} , we cannot apply $\cos^{-1}(\cos x) = x$. Instead, we find $\cos(3\pi/2)$, which is 0, and substitute to get $\cos^{-1} 0 = \pi/2$. Thus, $\cos^{-1}[\cos(3\pi/2)] = \pi/2$.

e) $\sin^{-1}[\cos(-\pi/6)] = \sin^{-1} \frac{\sqrt{3}}{2} \quad \cos(-\pi/6) = \sqrt{3}/2$
 $= \pi/3$

f) $\tan\left[\cos^{-1}\left(-\frac{1}{2}\right)\right] = \tan(2\pi/3) \quad \cos^{-1}\left(-\frac{1}{2}\right) = 2\pi/3$
 $= -\sqrt{3}$

Find: $\sin\left(\cos^{-1} \frac{x}{5}\right)$.

Let θ be the angle whose cosine is $x/5$: $\cos \theta = x/5$. Considering all values of x , we draw right triangles, in which the length of the hypotenuse is 5 and the length of one leg is x . The other leg in each triangle is $\sqrt{25 - x^2}$.

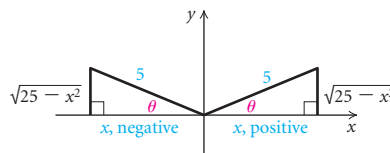

Thus, $\sin\left(\cos^{-1} \frac{x}{5}\right) = \frac{\sqrt{25 - x^2}}{5}$.

SECTION 7.5: SOLVING TRIGONOMETRIC EQUATIONS

Trigonometric Equations

When an equation contains a trigonometric expression with a variable, it is called a trigonometric equation. To solve such equations, we find all values for the variable that make the equation true.

In most applications, it is sufficient to find just the solutions from 0 to 2π , or from 0° to 360° . We then remember that any multiple of 2π , or 360° , can be added to obtain the rest of the solutions.

Solve $3 \tan x = \sqrt{3}$. Find *all* solutions.

$$\begin{aligned} 3 \tan x &= \sqrt{3} \\ \tan x &= \sqrt{3}/3 \end{aligned}$$

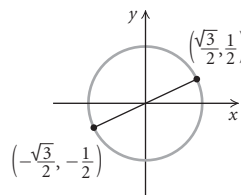

The solutions are numbers that have a tangent of $\sqrt{3}/3$. There are just two points on the unit circle for which the tangent is $\sqrt{3}/3$. They are the points corresponding to $\pi/6$ and $7\pi/6$. The solutions are $\pi/6 + k\pi$, where k is any integer.

Solve: $\sin x = 1 - 2 \sin^2 x$ in $[0^\circ, 360^\circ)$.

$$\begin{aligned} \sin x &= 1 - 2 \sin^2 x \\ 2 \sin^2 x + \sin x - 1 &= 0 \\ (2 \sin x - 1)(\sin x + 1) &= 0 \\ 2 \sin x - 1 = 0 &\text{ or } \sin x + 1 = 0 \\ \sin x = \frac{1}{2} &\text{ or } \sin x = -1 \end{aligned}$$

Thus, $x = 30^\circ, 150^\circ$ or $x = 270^\circ$. All values check. The solutions in $[0^\circ, 360^\circ)$ are $30^\circ, 150^\circ$, and 270° .

Solve: $\sin 2x \cos x + \cos x = 0$ in $[0, 2\pi)$.

$$\begin{aligned} \sin 2x \cos x + \cos x &= 0 \\ \cos x (\sin 2x + 1) &= 0 \\ \cos x = 0 &\text{ or } \sin 2x + 1 = 0 \\ \cos x = 0 &\text{ or } \sin 2x = -1 \\ x = \pi/2, 3\pi/2 &\text{ or } 2x = 3\pi/2 \\ &x = 3\pi/4 \end{aligned}$$

All values check. The solutions in $[0, 2\pi)$ are $\pi/2, 3\pi/4$, and $3\pi/2$.

Solve $5 \cos^2 x = 2 \cos x + 6$ in $[0^\circ, 360^\circ)$.

$$\begin{aligned} 5 \cos^2 x - 2 \cos x - 6 &= 0 \\ \cos x &= \frac{2 \pm \sqrt{124}}{10} && \text{Using the quadratic formula} \\ \cos x &\approx 1.3136 &\text{ or } &\cos x \approx -0.9136 \end{aligned}$$

Since cosine values are never greater than 1, $\cos x \approx 1.3136$ has no solution. Using $\cos x \approx -0.9136$, we find that $\cos^{-1}(-0.9136) \approx 156.01^\circ$. Thus the solutions in $[0^\circ, 360^\circ)$ are 156.01° and $360^\circ - 156.01^\circ$, or 203.99° .

REVIEW EXERCISES

Determine whether the statement is true or false.

- $\sin^2 s \neq \sin s^2$. [7.1]
- Given $0 < \alpha < \pi/2$ and $0 < \beta < \pi/2$ and that $\sin(\alpha + \beta) = 1$ and $\sin(\alpha - \beta) = 0$, then $\alpha = \pi/4$. [7.1]
- If the terminal side of θ is in quadrant IV, then $\tan \theta < \cos \theta$. [7.1]
- $\cos 5\pi/12 = \cos 7\pi/12$. [7.2]
- Given that $\sin \theta = -\frac{2}{5}$, $\tan \theta < \cos \theta$. [7.1]

Complete the Pythagorean identity. [7.1]

- $1 + \cot^2 x =$
- $\sin^2 x + \cos^2 x =$

Multiply and simplify. [7.1]

- $(\tan y - \cot y)(\tan y + \cot y)$
- $(\cos x + \sec x)^2$

Factor and simplify. [7.1]

- $\sec x \csc x - \cos^2 x$
- $3 \sin^2 y - 7 \sin y - 20$
- $1000 - \cos^3 u$

Simplify. [7.1]

- $\frac{\sec^4 x - \tan^4 x}{\sec^2 x + \tan^2 x}$
- $\frac{2 \sin^2 x}{\cos^3 x} \cdot \left(\frac{\cos x}{2 \sin x}\right)^2$
- $\frac{3 \sin x}{\cos^2 x} \cdot \frac{\cos^2 x + \cos x \sin x}{\sin^2 x - \cos^2 x}$
- $\frac{3}{\cos y - \sin y} - \frac{2}{\sin^2 y - \cos^2 y}$
- $\left(\frac{\cot x}{\csc x}\right)^2 + \frac{1}{\csc^2 x}$
- $\frac{4 \sin x \cos^2 x}{16 \sin^2 x \cos x}$

In Exercises 19–21, assume that all radicands are nonnegative.

- Simplify:
 $\sqrt{\sin^2 x + 2 \cos x \sin x + \cos^2 x}$. [7.1]

- Rationalize the denominator: $\sqrt{\frac{1 + \sin x}{1 - \sin x}}$. [7.1]

- Rationalize the numerator: $\sqrt{\frac{\cos x}{\tan x}}$. [7.1]

- Given that $x = 3 \tan \theta$, express $\sqrt{9 + x^2}$ as a trigonometric function without radicals. Assume that $0 < \theta < \pi/2$. [7.1]

Use the sum and difference formulas to write equivalent expressions. You need not simplify. [7.1]

- $\cos\left(x + \frac{3\pi}{2}\right)$
- $\tan(45^\circ - 30^\circ)$

- Simplify: $\cos 27^\circ \cos 16^\circ + \sin 27^\circ \sin 16^\circ$. [7.1]

- Find $\cos 165^\circ$ exactly. [7.1]

- Given that $\tan \alpha = \sqrt{3}$ and $\sin \beta = \sqrt{2}/2$ and that α and β are between 0 and $\pi/2$, evaluate $\tan(\alpha - \beta)$ exactly. [7.1]

- Assume that $\sin \theta = 0.5812$ and $\cos \phi = 0.2341$ and that both θ and ϕ are first-quadrant angles. Evaluate $\cos(\theta + \phi)$. [7.1]

Complete the cofunction identity. [7.2]

- $\cos\left(x + \frac{\pi}{2}\right) =$
- $\cos\left(\frac{\pi}{2} - x\right) =$

- $\sin\left(x - \frac{\pi}{2}\right) =$

- Given that $\cos \alpha = -\frac{3}{5}$ and that the terminal side is in quadrant III:

- Find the other function values for α . [7.2]

- Find the six function values for $\pi/2 - \alpha$. [7.2]

- Find the six function values for $\alpha + \pi/2$. [7.2]

- Find an equivalent expression for $\csc\left(x - \frac{\pi}{2}\right)$. [7.2]

- Find $\tan 2\theta$, $\cos 2\theta$, and $\sin 2\theta$ and the quadrant in which 2θ lies, where $\cos \theta = -\frac{4}{5}$ and θ is in quadrant III. [7.2]

- Find $\sin \frac{\pi}{8}$ exactly. [7.2]

36. Given that $\sin \beta = 0.2183$ and β is in quadrant I, find $\sin 2\beta$, $\cos \frac{\beta}{2}$, and $\cos 4\beta$. [7.2]

Simplify. [7.2]

37. $1 - 2 \sin^2 \frac{x}{2}$

38. $(\sin x + \cos x)^2 - \sin 2x$

39. $2 \sin x \cos^3 x + 2 \sin^3 x \cos x$

40. $\frac{2 \cot x}{\cot^2 x - 1}$

Prove the identity. [7.3]

41. $\frac{1 - \sin x}{\cos x} = \frac{\cos x}{1 + \sin x}$

42. $\frac{1 + \cos 2\theta}{\sin 2\theta} = \cot \theta$

43. $\frac{\tan y + \sin y}{2 \tan y} = \cos^2 \frac{y}{2}$

44. $\frac{\sin x - \cos x}{\cos^2 x} = \frac{\tan^2 x - 1}{\sin x + \cos x}$

Use the product-to-sum identities and the sum-to-product identities to find identities for each of the following. [7.3]

45. $3 \cos 2\theta \sin \theta$

46. $\sin \theta - \sin 4\theta$

Find each of the following exactly in both radians and degrees. [7.4]

47. $\sin^{-1} \left(-\frac{1}{2} \right)$

48. $\cos^{-1} \frac{\sqrt{3}}{2}$

49. $\tan^{-1} 1$

50. $\sin^{-1} 0$

Use a calculator to find each of the following in radians, rounded to four decimal places, and in degrees, rounded to the nearest tenth of a degree. [7.4]

51. $\cos^{-1} (-0.2194)$

52. $\cot^{-1} 2.381$

Evaluate. [7.4]

53. $\cos \left(\cos^{-1} \frac{1}{2} \right)$

54. $\tan^{-1} \left(\tan \frac{\sqrt{3}}{3} \right)$

55. $\sin^{-1} \left(\sin \frac{\pi}{7} \right)$

56. $\cos \left(\sin^{-1} \frac{\sqrt{2}}{2} \right)$

Find each of the following. [7.4]

57. $\cos \left(\tan^{-1} \frac{b}{3} \right)$

58. $\cos \left(2 \sin^{-1} \frac{4}{5} \right)$

Solve, finding all solutions. Express the solutions in both radians and degrees. [7.5]

59. $\cos x = -\frac{\sqrt{2}}{2}$

60. $\tan x = \sqrt{3}$

Solve, finding all solutions in $[0, 2\pi)$. [7.5]

61. $4 \sin^2 x = 1$

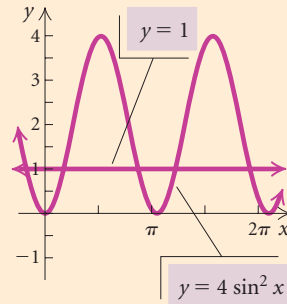

62. $\sin 2x \sin x - \cos x = 0$

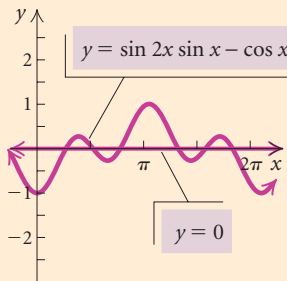

63. $2 \cos^2 x + 3 \cos x = -1$

64. $\sin^2 x - 7 \sin x = 0$

65. $\csc^2 x - 2 \cot^2 x = 0$

66. $\sin 4x + 2 \sin 2x = 0$

67. $2 \cos x + 2 \sin x = \sqrt{2}$

68. $6 \tan^2 x = 5 \tan x + \sec^2 x$

69. Which of the following is the domain of the function $\cos^{-1} x$? [7.4]

- A. $(0, \pi)$ B. $[-1, 1]$
C. $[-\pi/2, \pi/2]$ D. $(-\infty, \infty)$

70. Simplify: $\sin^{-1} \left(\sin \frac{7\pi}{6} \right)$. [7.4]

- A. $-\pi/6$ B. $7\pi/6$
C. $-1/2$ D. $11\pi/6$

71. The graph of $f(x) = \sin^{-1} x$ is which of the following? [7.4]

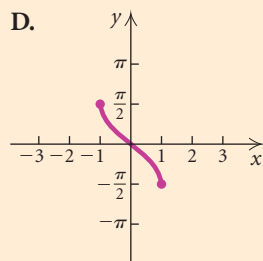
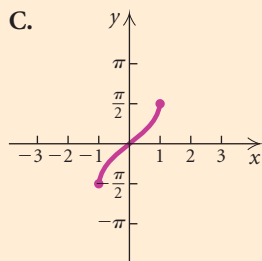
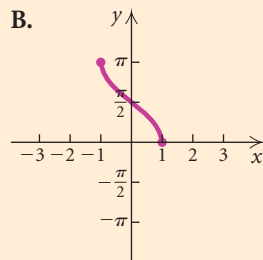
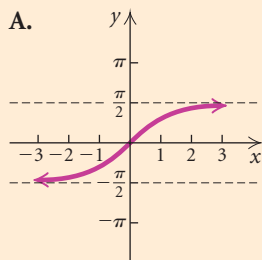

Synthesis

72. Find the measure of the angle from l_1 to l_2 :
 $l_1: x + y = 3$ $l_2: 2x - y = 5$. [7.1]
73. Find an identity for $\cos(u + v)$ involving only cosines. [7.1], [7.2]
74. Simplify: $\cos\left(\frac{\pi}{2} - x\right)[\csc x - \sin x]$. [7.2]
75. Find $\sin \theta$, $\cos \theta$, and $\tan \theta$ under the given conditions:
 $\sin 2\theta = \frac{1}{5}$, $\frac{\pi}{2} \leq 2\theta < \pi$. [7.2]

76. Prove the following equation to be an identity:

$$\ln e^{\sin t} = \sin t. \quad [7.3]$$

77. Graph: $y = \sec^{-1} x$. [7.4]

78. Show that

$$\tan^{-1} x = \frac{\sin^{-1} x}{\cos^{-1} x}$$

is *not* an identity. [7.4]

79. Solve $e^{\cos x} = 1$ in $[0, 2\pi)$. [7.5]

Collaborative Discussion and Writing

80. Why are the ranges of the inverse trigonometric functions restricted? [7.4]
81. Jan lists her answer to a problem as $\pi/6 + k\pi$, for any integer k , while Jacob lists his answer as $\pi/6 + 2k\pi$ and $7\pi/6 + 2k\pi$, for any integer k . Are their answers equivalent? Why or why not? [7.5]
82. How does the graph of $y = \sin^{-1} x$ differ from the graph of $y = \sin x$? [7.4]
83. What is the difference between a trigonometric equation that is an identity and a trigonometric equation that is not an identity? Give an example of each. [7.1], [7.5]
84. Why is it that
 $\sin \frac{5\pi}{6} = \frac{1}{2}$, but $\sin^{-1}\left(\frac{1}{2}\right) \neq \frac{5\pi}{6}$? [7.4]

Chapter 7 Test

Simplify.

$$1. \frac{2 \cos^2 x - \cos x - 1}{\cos x - 1} \quad 2. \left(\frac{\sec x}{\tan x} \right)^2 - \frac{1}{\tan^2 x}$$

3. Rationalize the denominator:

$$\sqrt{\frac{1 - \sin \theta}{1 + \sin \theta}}$$

Assume that the radicand is nonnegative.

4. Given that $x = 2 \sin \theta$, express $\sqrt{4 - x^2}$ as a trigonometric function without radicals. Assume $0 < \theta < \pi/2$.

Use the sum or difference identities to evaluate exactly.

$$5. \sin 75^\circ \quad 6. \tan \frac{\pi}{12}$$

7. Assuming that $\cos u = \frac{5}{13}$ and $\cos v = \frac{12}{13}$ and that u and v are between 0 and $\pi/2$, evaluate $\cos(u - v)$ exactly.

8. Given that $\cos \theta = -\frac{2}{3}$ and that the terminal side is in quadrant II, find $\cos(\pi/2 - \theta)$.

9. Given that $\sin \theta = -\frac{4}{5}$ and θ is in quadrant III, find $\sin 2\theta$ and the quadrant in which 2θ lies.

10. Use a half-angle identity to evaluate $\cos \frac{\pi}{12}$ exactly.

11. Given that $\sin \theta = 0.6820$ and that θ is in quadrant I, find $\cos(\theta/2)$.

12. Simplify: $(\sin x + \cos x)^2 - 1 + 2 \sin 2x$.

Prove each of the following identities.

$$13. \csc x - \cos x \cot x = \sin x$$

$$14. (\sin x + \cos x)^2 = 1 + \sin 2x$$

$$15. (\csc \beta + \cot \beta)^2 = \frac{1 + \cos \beta}{1 - \cos \beta}$$

$$16. \frac{1 + \sin \alpha}{1 + \csc \alpha} = \frac{\tan \alpha}{\sec \alpha}$$

Use the product-to-sum identities and the sum-to-product identities to find identities for each of the following.

$$17. \cos 8\alpha - \cos \alpha$$

$$18. 4 \sin \beta \cos 3\beta$$

19. Find $\sin^{-1}\left(-\frac{\sqrt{2}}{2}\right)$ exactly in degrees.

20. Find $\tan^{-1} \sqrt{3}$ exactly in radians.

21. Use a calculator to find $\cos^{-1}(-0.6716)$ in radians, rounded to four decimal places.

22. Evaluate $\cos\left(\sin^{-1}\frac{1}{2}\right)$.

23. Find $\tan\left(\sin^{-1}\frac{5}{x}\right)$.

24. Evaluate $\cos\left(\sin^{-1}\frac{1}{2} + \cos^{-1}\frac{1}{2}\right)$.

Solve, finding all solutions in $[0, 2\pi)$.

$$25. 4 \cos^2 x = 3$$

$$26. 2 \sin^2 x = \sqrt{2} \sin x$$

$$27. \sqrt{3} \cos x + \sin x = 1$$

28. The graph of $f(x) = \cos^{-1} x$ is which of the following?

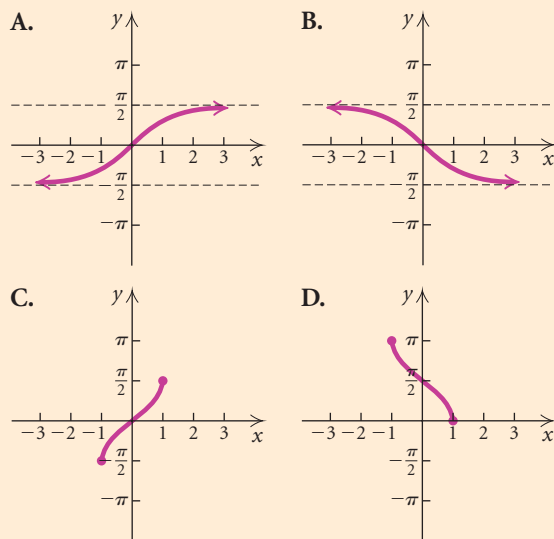

Synthesis

29. Find $\cos \theta$, given that $\cos 2\theta = \frac{5}{6}$, $\frac{3\pi}{2} < \theta < 2\pi$.

Applications of Trigonometry

CHAPTER

8



Application

The Vietnam Veterans Memorial, in Washington, D.C., designed by Maya Lin, consists of two congruent black granite walls on which 58,191 names are inscribed in chronological order of the date of the casualty. Each wall closely approximates a triangle. The height of the memorial at the vertex is about 120.5 in. The angles formed by the top and the bottom of a wall with the height of the memorial are about 89.4056° and 88.2625° , respectively. Find the lengths of the top and bottom of a wall rounded to the nearest tenth of an inch. (Sources: www.tourofcdc.org; Maya Lin, Designer, New York, NY; National Park Service, U.S. Department of the Interior; Jennifer Talken-Spaulding, Cultural Resources Program manager, National Mall and Memorial Parks, Washington, D.C.; Bryan Swank, Unique Products, Columbus, IN)

This problem appears as Example 2 in Section 8.1.

- 8.1** The Law of Sines
- 8.2** The Law of Cosines
- 8.3** Complex Numbers: Trigonometric Form
- Mid-Chapter Mixed Review
- 8.4** Polar Coordinates and Graphs
- Visualizing the Graph
- 8.5** Vectors and Applications
- 8.6** Vector Operations
- Study Guide
- Review Exercises
- Chapter Test

The Law of Sines

8.1

- ▶ Use the law of sines to solve triangles.
- ▶ Find the area of any triangle given the lengths of two sides and the measure of the included angle.

To **solve a triangle** means to find the lengths of all its sides and the measures of all its angles. We solved right triangles in Section 6.2. For review, let's solve the right triangle shown below. We begin by listing the known measures:

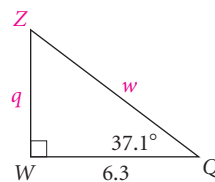

$$\begin{aligned} Q &= 37.1^\circ, & q &= ?, \\ W &= 90^\circ, & w &= ?, \\ Z &= ?, & z &= 6.3. \end{aligned}$$

Since the sum of the three angle measures of any triangle is 180° , we can immediately find the measure of the third angle:

$$\begin{aligned} Z &= 180^\circ - (90^\circ + 37.1^\circ) \\ &= 52.9^\circ. \end{aligned}$$

Then using the tangent ratio and the cosine ratio, respectively, we can find q and w :

$$\begin{aligned} \tan 37.1^\circ &= \frac{q}{6.3}, \quad \text{or} \\ q &= 6.3 \tan 37.1^\circ \approx 4.8, \end{aligned}$$

$$\text{and} \quad \cos 37.1^\circ = \frac{6.3}{w}, \quad \text{or}$$

$$w = \frac{6.3}{\cos 37.1^\circ} \approx 7.9.$$

Now all six measures are known and we have solved triangle QWZ:

$$\begin{aligned} Q &= 37.1^\circ, & q &\approx 4.8, \\ W &= 90^\circ, & w &\approx 7.9, \\ Z &= 52.9^\circ, & z &= 6.3. \end{aligned}$$

▶ Solving Oblique Triangles

The trigonometric functions can also be used to solve triangles that are not right triangles. Such triangles are called **oblique**. Any triangle, right or oblique, can be solved *if at least one side and any other two measures are known*. The five possible situations are illustrated on the next page.

1. **AAS**: Two angles of a triangle and a side opposite one of them are known.

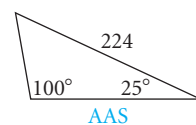

2. **ASA**: Two angles of a triangle and the included side are known.

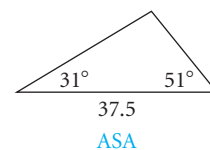

3. **SSA**: Two sides of a triangle and an angle opposite one of them are known. (In this case, there may be no solution, one solution, or two solutions. The latter is known as the ambiguous case.)

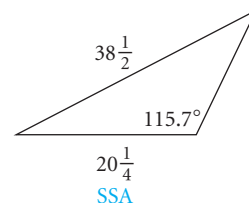

4. **SAS**: Two sides of a triangle and the included angle are known.

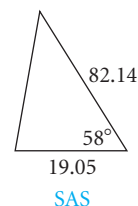

5. **SSS**: All three sides of the triangle are known.

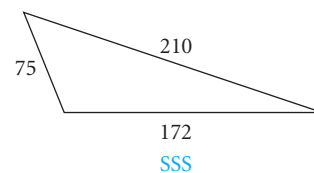

The list above does not include the situation in which only the three angle measures are given. The reason for this lies in the fact that the angle measures determine *only the shape* of the triangle and *not the size*, as shown with the following triangles. Thus we cannot solve a triangle when only the three angle measures are given.

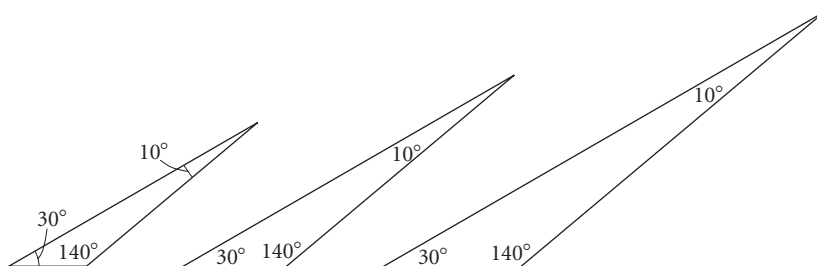

In order to solve oblique triangles, we must derive the *law of sines* and the *law of cosines*. The law of sines applies to the first three situations listed on the preceding page. The law of cosines, which we develop in Section 8.2, applies to the last two situations.

► The Law of Sines

We consider any oblique triangle. It may or may not have an obtuse angle. Although we look at only the acute-triangle case, the derivation of the obtuse-triangle case is essentially the same.

In acute $\triangle ABC$ at left, we have drawn an altitude from vertex C . It has length h . From $\triangle ADC$, we have

$$\sin A = \frac{h}{b}, \quad \text{or} \quad h = b \sin A.$$

From $\triangle BDC$, we have

$$\sin B = \frac{h}{a}, \quad \text{or} \quad h = a \sin B.$$

With $h = b \sin A$ and $h = a \sin B$, we now have

$$a \sin B = b \sin A$$

$$\frac{a \sin B}{\sin A \sin B} = \frac{b \sin A}{\sin A \sin B} \quad \text{Dividing by } \sin A \sin B$$

$$\frac{a}{\sin A} = \frac{b}{\sin B}. \quad \text{Simplifying}$$

There is no danger of dividing by 0 here because we are dealing with triangles whose angles are never 0° or 180° . Thus the sine value will never be 0.

If we were to consider altitudes from vertex A and vertex B in the triangle shown above, the same argument would give us

$$\frac{b}{\sin B} = \frac{c}{\sin C} \quad \text{and} \quad \frac{a}{\sin A} = \frac{c}{\sin C}.$$

We combine these results to obtain the law of sines.

The Law of Sines

In any triangle ABC ,

$$\frac{a}{\sin A} = \frac{b}{\sin B} = \frac{c}{\sin C}.$$

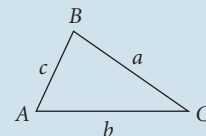

The law of sines can also be expressed as

$$\frac{\sin A}{a} = \frac{\sin B}{b} = \frac{\sin C}{c}.$$

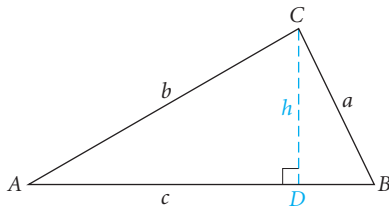

STUDY TIP

Maximize the learning that you accomplish during a lecture by preparing for the class. Your time is valuable; let each lecture become a positive learning experience. Review the lesson from the previous class and read the section that will be covered in the next lecture. Write down questions you want answered and take an active part in class discussion.

Solving Triangles (AAS and ASA)

When two angles and a side of any triangle are known, the law of sines can be used to solve the triangle.

EXAMPLE 1 In $\triangle EFG$, $e = 4.56$, $E = 43^\circ$, and $G = 57^\circ$. Solve the triangle.

Solution We first make a drawing. We know three of the six measures:

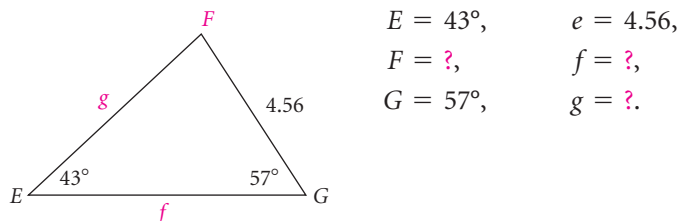

From the figure, we see that we have the **AAS** situation. We begin by finding F :

$$F = 180^\circ - (43^\circ + 57^\circ) = 80^\circ.$$

We can now find the other two sides, using the law of sines:

$$\begin{aligned} \frac{f}{\sin F} &= \frac{e}{\sin E} \\ \frac{f}{\sin 80^\circ} &= \frac{4.56}{\sin 43^\circ} && \text{Substituting} \\ f &= \frac{4.56 \sin 80^\circ}{\sin 43^\circ} && \text{Solving for } f \\ f &\approx 6.58; \end{aligned}$$

$$\begin{aligned} \frac{g}{\sin G} &= \frac{e}{\sin E} \\ \frac{g}{\sin 57^\circ} &= \frac{4.56}{\sin 43^\circ} && \text{Substituting} \\ g &= \frac{4.56 \sin 57^\circ}{\sin 43^\circ} && \text{Solving for } g \\ g &\approx 5.61. \end{aligned}$$

Thus we have solved the triangle:

$$\begin{aligned} E &= 43^\circ, & e &= 4.56, \\ F &= 80^\circ, & f &\approx 6.58, \\ G &= 57^\circ, & g &\approx 5.61. \end{aligned}$$

Now Try Exercise 1.

The law of sines is frequently used in determining distances.

EXAMPLE 2 *Vietnam Veterans Memorial.* The Vietnam Veterans Memorial, in Washington, D.C., designed by Maya Lin, consists of two congruent black granite walls on which 58,191 names are inscribed in chronological order of the date of the casualty. Each wall closely approximates a triangle. The height of the memorial at the vertex is about 120.5 in. The angles formed by the top and the bottom of a wall with the height of the memorial are about 89.4056° and 88.2625° , respectively. Find the lengths of the top and bottom of a wall rounded to the nearest tenth of an inch. (Sources: www.tourofcdc.org; Maya Lin, Designer, New York, NY; National Park Service, U.S. Department of the Interior; Jennifer Talken-Spaulling, Cultural Resources Program manager, National Mall and Memorial Parks, Washington, D.C.; Bryan Swank, Unique Products, Columbus, IN)

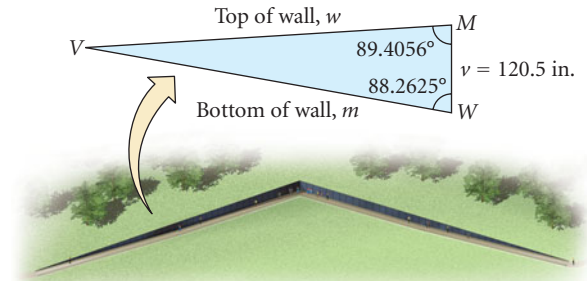

Source: www.tourofcdc.org

Solution We first find angle V :

$$180^\circ - (89.4056^\circ + 88.2625^\circ) = 2.3319^\circ.$$

Because the application involves the **ASA** situation, we use the law of sines to determine m and w .

$$\begin{aligned} \frac{m}{\sin M} &= \frac{v}{\sin V} \\ \frac{m}{\sin 89.4056^\circ} &= \frac{120.5 \text{ in.}}{\sin 2.3319^\circ} && \text{Substituting} \\ m &= \frac{120.5 \text{ in.} (\sin 89.4056^\circ)}{\sin 2.3319^\circ} && \text{Solving for } m \\ m &\approx 2961.4 \text{ in.} \end{aligned}$$

$$\begin{aligned} \frac{w}{\sin W} &= \frac{v}{\sin V} \\ \frac{w}{\sin 88.2625^\circ} &= \frac{120.5 \text{ in.}}{\sin 2.3319^\circ} && \text{Substituting} \\ w &= \frac{120.5 \text{ in.} (\sin 88.2625^\circ)}{\sin 2.3319^\circ} && \text{Solving for } w \\ w &\approx 2960.2 \text{ in.} \end{aligned}$$

Thus, $m \approx 2961.4$ in. and $w \approx 2960.2$ in.

Now Try Exercise 23.

► Solving Triangles (SSA)

When two sides of a triangle and an angle opposite one of them are known, the law of sines can be used to solve the triangle.

Suppose for $\triangle ABC$ that b , c , and B are given. The various possibilities are as shown in the eight cases that follow: 5 cases when B is acute and 3 cases when B is obtuse. Note that $b < c$ in cases 1, 2, 3, and 6; $b = c$ in cases 4 and 7; and $b > c$ in cases 5 and 8.

Angle B Is Acute

Case 1: No solution

$b < c$; side b is too short to reach the base. No triangle is formed.

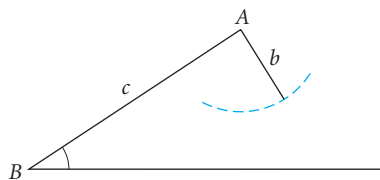

Case 2: One solution

$b < c$; side b just reaches the base and is perpendicular to it.

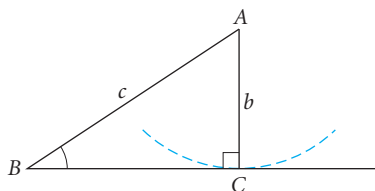

Case 3: Two solutions

$b < c$; an arc of radius b meets the base at two points. (This case is called the **ambiguous case**.)

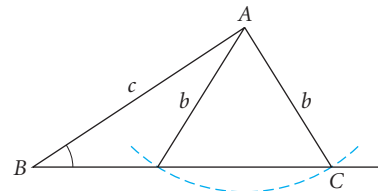

Case 4: One solution

$b = c$; an arc of radius b meets the base at just one point other than B .

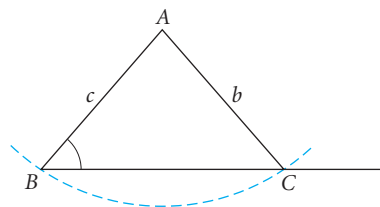

Case 5: One solution

$b > c$; an arc of radius b meets the base at just one point.

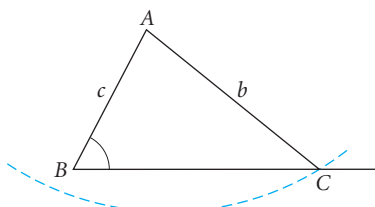

Angle B Is Obtuse

Case 6: No solution

$b < c$; side b is too short to reach the base. No triangle is formed.

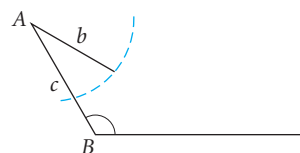

Case 7: No solution

$b = c$; an arc of radius b meets the base only at point B . No triangle is formed.

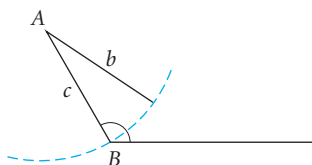

Case 8: One solution

$b > c$; an arc of radius b meets the base at just one point.

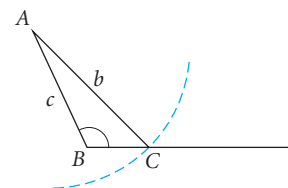

The eight cases above lead us to three possibilities in the SSA situation: *no* solution, *one* solution, or *two* solutions. Let's investigate these possibilities further, looking for ways to recognize the number of solutions.

EXAMPLE 3 *No solution.* In $\triangle QRS$, $q = 15$, $r = 28$, and $Q = 43.6^\circ$. Solve the triangle.

Solution We make a drawing and list the known measures:

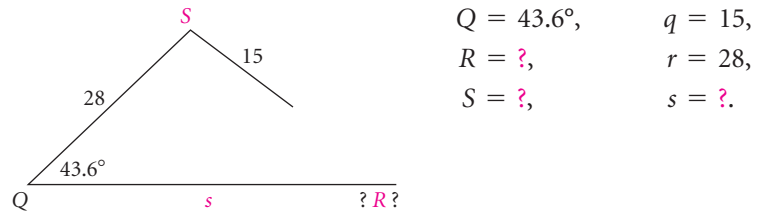

We note the **SSA** situation and use the law of sines to find R :

$$\frac{q}{\sin Q} = \frac{r}{\sin R}$$

$$\frac{15}{\sin 43.6^\circ} = \frac{28}{\sin R} \quad \text{Substituting}$$

$$\sin R = \frac{28 \sin 43.6^\circ}{15} \quad \text{Solving for } \sin R$$

$$\sin R \approx 1.2873.$$

Since there is no angle with a sine greater than 1, there is *no solution*.

Now Try Exercise 13.

EXAMPLE 4 *One solution.* In $\triangle XYZ$, $x = 23.5$, $y = 9.8$, and $X = 39.7^\circ$. Solve the triangle.

Solution We make a drawing and organize the given information:

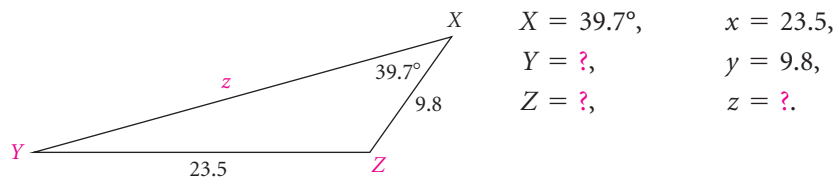

We see the **SSA** situation and begin by finding Y with the law of sines:

$$\frac{x}{\sin X} = \frac{y}{\sin Y}$$

$$\frac{23.5}{\sin 39.7^\circ} = \frac{9.8}{\sin Y} \quad \text{Substituting}$$

$$\sin Y = \frac{9.8 \sin 39.7^\circ}{23.5} \quad \text{Solving for } \sin Y$$

$$\sin Y \approx 0.2664.$$

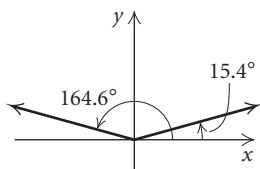

There are two angles less than 180° with a sine of 0.2664. They are 15.4° and 164.6° , to the nearest tenth of a degree. An angle of 164.6° cannot be an angle of this triangle because the triangle already has an angle of 39.7° and these two angles would total more than 180° . Thus, 15.4° is the only possibility for Y . Therefore,

$$Z \approx 180^\circ - (39.7^\circ + 15.4^\circ) \approx 124.9^\circ.$$

We now find z :

$$\begin{aligned} \frac{z}{\sin Z} &= \frac{x}{\sin X} \\ \frac{z}{\sin 124.9^\circ} &= \frac{23.5}{\sin 39.7^\circ} && \text{Substituting} \\ z &= \frac{23.5 \sin 124.9^\circ}{\sin 39.7^\circ} && \text{Solving for } z \\ z &\approx 30.2. \end{aligned}$$

We have now solved the triangle:

$$\begin{aligned} X &= 39.7^\circ, & x &= 23.5, \\ Y &\approx 15.4^\circ, & y &= 9.8, \\ Z &\approx 124.9^\circ, & z &\approx 30.2. \end{aligned}$$

➔ Now Try Exercise 5.

The next example illustrates the ambiguous case in which there are two possible solutions.

EXAMPLE 5 *Two solutions.* In $\triangle ABC$, $b = 15$, $c = 20$, and $B = 29^\circ$. Solve the triangle.

Solution We make a drawing, list the known measures, and see that we again have the **SSA** situation.

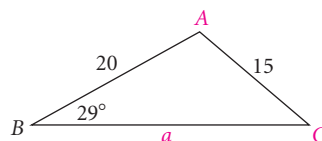

$$\begin{aligned} A &= ?, & a &= ?, \\ B &= 29^\circ, & b &= 15, \\ C &= ?, & c &= 20 \end{aligned}$$

We first find C :

$$\begin{aligned} \frac{b}{\sin B} &= \frac{c}{\sin C} \\ \frac{15}{\sin 29^\circ} &= \frac{20}{\sin C} && \text{Substituting} \\ \sin C &= \frac{20 \sin 29^\circ}{15} \approx 0.6464. && \text{Solving for } \sin C \end{aligned}$$

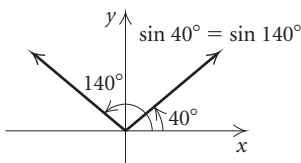

There are two angles less than 180° with a sine of 0.6464. They are 40° and 140° , to the nearest degree. This gives us two possible solutions.

Possible Solution I.

If $C = 40^\circ$, then

$$A = 180^\circ - (29^\circ + 40^\circ) = 111^\circ.$$

Then we find a :

$$\begin{aligned}\frac{a}{\sin A} &= \frac{b}{\sin B} \\ \frac{a}{\sin 111^\circ} &= \frac{15}{\sin 29^\circ} \\ a &= \frac{15 \sin 111^\circ}{\sin 29^\circ} \approx 29.\end{aligned}$$

These measures make a triangle as shown below; thus we have a solution.

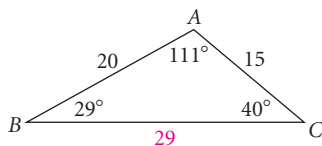
*Possible Solution II.*

If $C = 140^\circ$, then

$$A = 180^\circ - (29^\circ + 140^\circ) = 11^\circ.$$

Then we find a :

$$\begin{aligned}\frac{a}{\sin A} &= \frac{b}{\sin B} \\ \frac{a}{\sin 11^\circ} &= \frac{15}{\sin 29^\circ} \\ a &= \frac{15 \sin 11^\circ}{\sin 29^\circ} \approx 6.\end{aligned}$$

These measures make a triangle as shown below; thus we have a second solution.

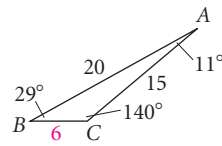

Now Try Exercise 3.

Examples 3–5 illustrate the SSA situation. Note that we need not memorize the eight cases or the procedures in finding no solution, one solution, or two solutions. When we are using the law of sines, the sine value leads us directly to the correct solution or solutions.

► The Area of a Triangle

The familiar formula for the area of a triangle, $A = \frac{1}{2}bh$, can be used only when h is known. However, we can use the method used to derive the law of sines to derive an area formula that does not involve the height.

Consider a general triangle $\triangle ABC$, with area K , as shown below.

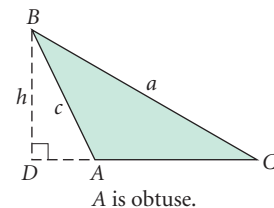
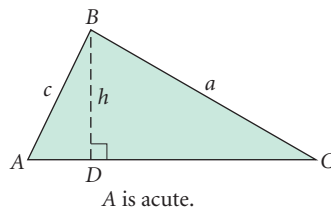

Note that in the triangle on the right, $\sin(\angle CAB) = \sin(\angle DAB)$, since $\sin A = \sin(180^\circ - A)$. Then in each $\triangle ADB$,

$$\sin A = \frac{h}{c}, \quad \text{or} \quad h = c \sin A.$$

Substituting into the formula $K = \frac{1}{2}bh$, we get

$$K = \frac{1}{2}bc \sin A.$$

Any pair of sides and the included angle could have been used. Thus we also have

$$K = \frac{1}{2}ab \sin C \quad \text{and} \quad K = \frac{1}{2}ac \sin B.$$

The Area of a Triangle

The area K of any $\triangle ABC$ is one-half of the product of the lengths of two sides and the sine of the included angle:

$$K = \frac{1}{2}bc \sin A = \frac{1}{2}ab \sin C = \frac{1}{2}ac \sin B.$$

EXAMPLE 6 *Area of a Triangular Garden.* A university landscape architecture department is designing a garden for a triangular area in a dormitory complex. Two sides of the garden, formed by the sidewalks in front of buildings A and B, measure 172 ft and 186 ft, respectively, and together form a 53° angle. The third side of the garden, formed by the sidewalk along Crossroads Avenue, measures 160 ft. What is the area of the garden, to the nearest square foot?



Solution Since we do not know a height of the triangle, we use the area formula:

$$K = \frac{1}{2}ab \sin C$$

$$K = \frac{1}{2} \cdot 186 \text{ ft} \cdot 172 \text{ ft} \cdot \sin 53^\circ$$

$$K \approx 12,775 \text{ ft}^2.$$

The area of the garden is approximately $12,775 \text{ ft}^2$.

 **Now Try Exercise 25.**

8.1

Exercise Set

Solve the triangle, if possible.

1.

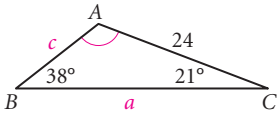

2.

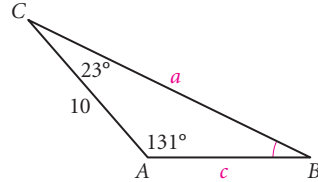

3.

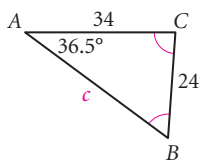

4.

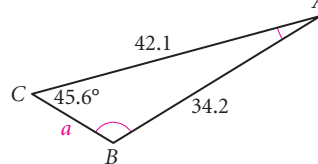

5. $C = 61^\circ 10'$, $c = 30.3$, $b = 24.2$

6. $A = 126.5^\circ$, $a = 17.2$, $c = 13.5$

7. $c = 3$ mi, $B = 37.48^\circ$, $C = 32.16^\circ$

8. $a = 2345$ mi, $b = 2345$ mi, $A = 124.67^\circ$

9. $b = 56.78$ yd, $c = 56.78$ yd, $C = 83.78^\circ$

10. $A = 129^\circ 32'$, $C = 18^\circ 28'$, $b = 1204$ in.

11. $a = 20.01$ cm, $b = 10.07$ cm, $A = 30.3^\circ$

12. $b = 4.157$ km, $c = 3.446$ km, $C = 51^\circ 48'$

13. $A = 89^\circ$, $a = 15.6$ in., $b = 18.4$ in.

14. $C = 46^\circ 32'$, $a = 56.2$ m, $c = 22.1$ m

15. $a = 200$ m, $A = 32.76^\circ$, $C = 21.97^\circ$

16. $B = 115^\circ$, $c = 45.6$ yd, $b = 23.8$ yd

Find the area of the triangle.

17. $B = 42^\circ$, $a = 7.2$ ft, $c = 3.4$ ft

18. $A = 17^\circ 12'$, $b = 10$ in., $c = 13$ in.

19. $C = 82^\circ 54'$, $a = 4$ yd, $b = 6$ yd

20. $C = 75.16^\circ$, $a = 1.5$ m, $b = 2.1$ m

21. $B = 135.2^\circ$, $a = 46.12$ ft, $c = 36.74$ ft

22. $A = 113^\circ$, $b = 18.2$ cm, $c = 23.7$ cm

23. **Meteor Crater.** The Meteor Crater in northern Arizona is the earliest discovered meteorite impact crater. A math student locates points R and S on opposite sides of the crater and point T 700 ft from S . The measure of $\angle RST$ and $\angle RTS$ are estimated to be 95° and 75° , respectively. What is the width of the crater?



24. **Lawn Irrigation.** Engleman Irrigation is installing a lawn irrigation system with three heads. They determine that the best locations for the heads A , B , and C are such that $\angle CAB$ is 40° and $\angle ACB$ is 45° and that the distance from A to B is 34 ft. Find the distance from B to C .

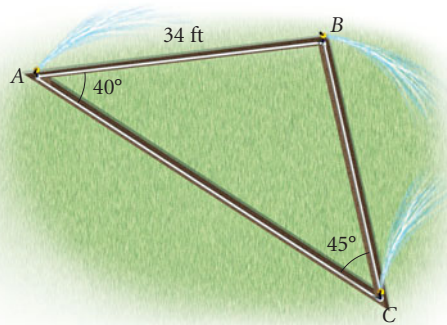

25. **Area of Back Yard.** A new homeowner has a triangular-shaped back yard. Two of the three sides measure 53 ft and 42 ft and form an included angle of 135° . To determine the amount of fertilizer and grass seed to be purchased, the owner must know, or at least approximate, the area of the yard. Find the area of the yard to the nearest square foot.
26. **Giraffe Exhibit.** A zoo is building a new giraffe exhibit and needs to fence an outdoor triangular area, with the barn forming one side of the triangle. The maintenance department has only 137 ft of fencing in stock. If one of the sides of the outdoor pen is

72 ft and the angle that it makes with the barn is 73° , does the zoo need to order more fencing?

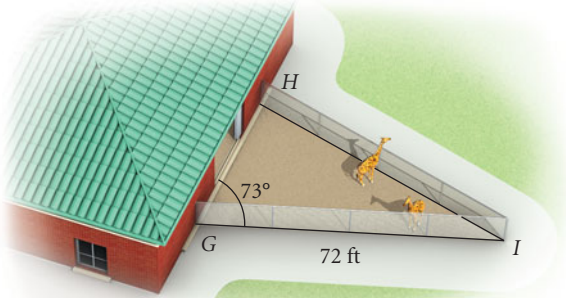

27. **Length of Pole.** A pole leans away from the sun at an angle of 7° to the vertical. When the angle of elevation of the sun is 51° , the pole casts a shadow 47 ft long on level ground. How long is the pole?

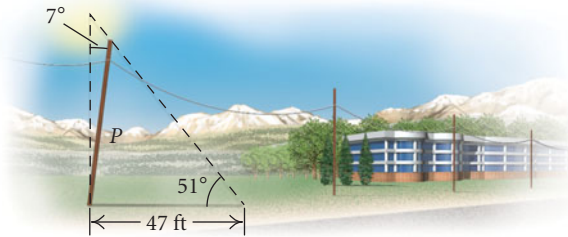

In Exercises 28–31, keep in mind the two types of bearing considered in Sections 6.2 and 6.3.

28. **Reconnaissance Airplane.** A reconnaissance airplane leaves its airport on the east coast of the United States and flies in a direction of 85° . Because of bad weather, it returns to another airport 230 km due north of its home base. To get to the new airport, it flies in a direction of 283° . What is the total distance that the airplane flew?

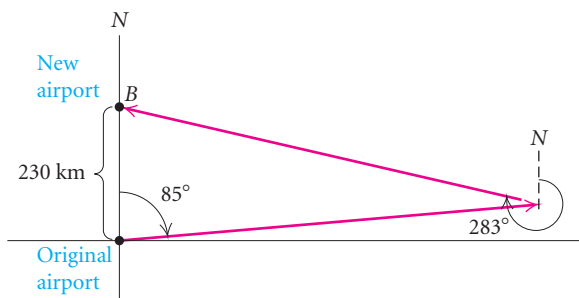

29. **Fire Tower.** A ranger in fire tower A spots a fire at a direction of 295° . A ranger in fire tower B, located 45 mi at a direction of 45° from tower A, spots the

same fire at a direction of 255° . How far from tower A is the fire? from tower B?

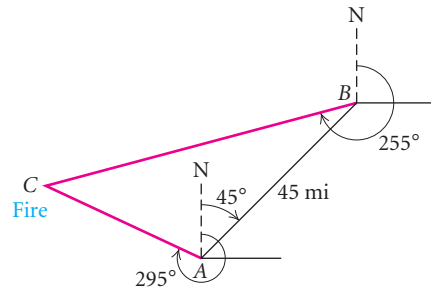

30. **Lighthouse.** A boat leaves lighthouse A and sails 5.1 km. At this time it is sighted from lighthouse B, 7.2 km west of A. The bearing of the boat from B is $N65^\circ 10' E$. How far is the boat from B?



31. **Distance to Nassau.** Miami, Florida, is located 178 mi $N73^\circ 10' W$ of Nassau. Because of an approaching hurricane, a cruise ship sailing in the region needs to know how far it is from Nassau. The ship's position is $N77^\circ 43' E$ of Miami and $N19^\circ 35' E$ of Nassau. How far is the ship from Nassau?



32. **Gears.** Three gears are arranged as shown in the figure below. Find the angle ϕ .

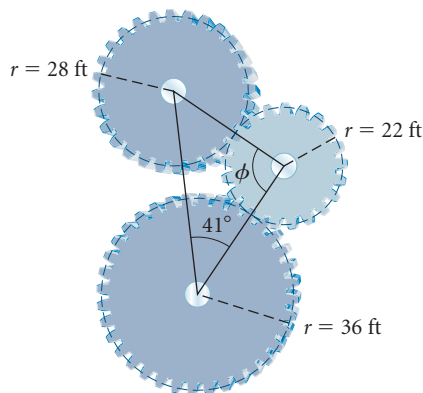

45. **Area of a Quadrilateral.** Prove that the area of a quadrilateral is one-half of the product of the lengths of its diagonals and the sine of the angle between the diagonals.

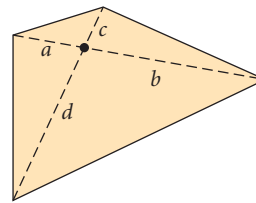

46. Find d .

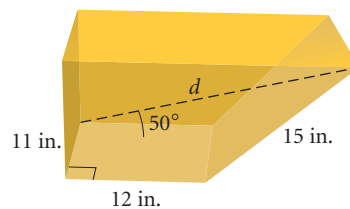

47. **Recording Studio.** A musician is constructing an octagonal recording studio in his home. The studio with dimensions shown below is to be built within a rectangular 31'9" by 29'9" room (Source: Tony Medeiros, Indianapolis, IN). Point D is 9" from wall 2, and points C and B are each 9" from wall 1. Using the law of sines and right triangles, determine to the nearest tenth of an inch how far point A is from wall 1 and from wall 4. (For more information on this studio, see Example 2 in Section 8.2.)

Skill Maintenance

Find the acute angle A , in both radians and degrees, for the given function value.

33. $\cos A = 0.2213$ 34. $\cos A = 1.5612$

Convert to decimal degree notation. Round to the nearest hundredth.

35. $18^\circ 14' 20''$ 36. $125^\circ 3' 42''$

37. Find the absolute value: $|-5|$.

Find the values.

38. $\cos \frac{\pi}{6}$ 39. $\sin 45^\circ$

40. $\sin 300^\circ$ 41. $\cos \left(-\frac{2\pi}{3} \right)$

42. Multiply: $(1 - i)(1 + i)$.

Synthesis

43. Prove the following area formulas for a general triangle ABC with area represented by K .

$$K = \frac{a^2 \sin B \sin C}{2 \sin A}, \quad K = \frac{c^2 \sin A \sin B}{2 \sin C},$$

$$K = \frac{b^2 \sin C \sin A}{2 \sin B}$$

44. **Area of a Parallelogram.** Prove that the area of a parallelogram is the product of two adjacent sides and the sine of the included angle.

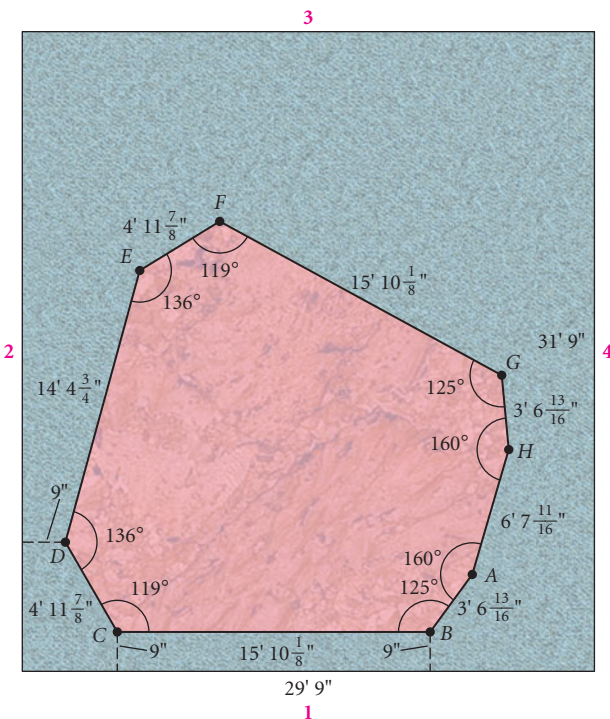

The Law of Cosines

8.2

- ▶ Use the law of cosines to solve triangles.
- ▶ Determine whether the law of sines or the law of cosines should be applied to solve a triangle.

The law of sines is used to solve triangles given a side and two angles (AAS and ASA) or given two sides and an angle opposite one of them (SSA). A second law, called the *law of cosines*, is needed to solve triangles given two sides and the included angle (SAS) or given three sides (SSS).

▶ The Law of Cosines

To derive this property, we consider any $\triangle ABC$ placed on a coordinate system. We position the origin at one of the vertices—say, C —and the positive half of the x -axis along one of the sides—say, side CB . Let (x, y) be the coordinates of vertex A . Point B has coordinates $(a, 0)$ and point C has coordinates $(0, 0)$.

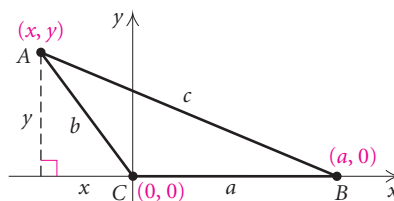

$$\text{Then } \cos C = \frac{x}{b}, \text{ so } x = b \cos C$$

$$\text{and } \sin C = \frac{y}{b}, \text{ so } y = b \sin C.$$

Thus point A has coordinates

$$(b \cos C, b \sin C).$$

Next, we use the distance formula to determine c^2 :

$$c^2 = (x - a)^2 + (y - 0)^2,$$

$$\text{or } c^2 = (b \cos C - a)^2 + (b \sin C - 0)^2.$$

Now we multiply and simplify:

$$c^2 = b^2 \cos^2 C - 2ab \cos C + a^2 + b^2 \sin^2 C$$

$$= a^2 + b^2(\sin^2 C + \cos^2 C) - 2ab \cos C$$

$$= a^2 + b^2 - 2ab \cos C.$$

Using the identity
 $\sin^2 \theta + \cos^2 \theta = 1$

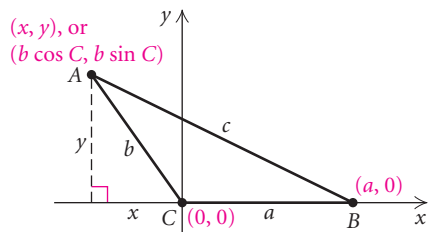

Had we placed the origin at one of the other vertices, we would have obtained

$$a^2 = b^2 + c^2 - 2bc \cos A$$

or $b^2 = a^2 + c^2 - 2ac \cos B.$

The Law of Cosines

In any triangle ABC ,

$$a^2 = b^2 + c^2 - 2bc \cos A,$$

$$b^2 = a^2 + c^2 - 2ac \cos B,$$

and $c^2 = a^2 + b^2 - 2ab \cos C.$

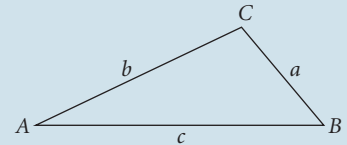

Thus, in any triangle, the square of a side is the sum of the squares of the other two sides, minus twice the product of those sides and the cosine of the included angle. When the included angle is 90° , the law of cosines reduces to the Pythagorean theorem.

The law of cosines can also be expressed as

$$\cos A = \frac{b^2 + c^2 - a^2}{2bc}, \quad \cos B = \frac{a^2 + c^2 - b^2}{2ac}, \quad \text{and} \quad \cos C = \frac{a^2 + b^2 - c^2}{2ab}.$$

► Solving Triangles (SAS)

When two sides of a triangle and the included angle are known, we can use the law of cosines to find the third side. The law of cosines or the law of sines can then be used to finish solving the triangle.

EXAMPLE 1 Solve $\triangle ABC$ if $a = 32$, $c = 48$, and $B = 125.2^\circ$.

Solution We first label a triangle with the known and unknown measures:

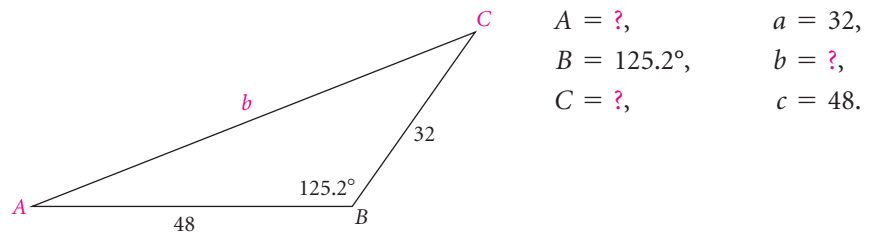

We can find the third side using the law of cosines, as follows:

$$b^2 = a^2 + c^2 - 2ac \cos B$$

$$b^2 = 32^2 + 48^2 - 2 \cdot 32 \cdot 48 \cos 125.2^\circ \quad \text{Substituting}$$

$$b^2 \approx 5098.8$$

$$b \approx 71.$$

We now have $a = 32$, $b \approx 71$, and $c = 48$, and we need to find the other two angle measures. At this point, we can find them in two ways. One way uses the law of sines. The ambiguous case may arise, however, and we would have to be alert to this possibility. The advantage of using the law of cosines again is that if we solve for the cosine and find that its value is *negative*, then we know that the angle is obtuse. If the value of the cosine is *positive*, then the angle is acute. Thus we use the law of cosines to find a second angle.

Let's find angle A . We select the formula from the law of cosines that contains $\cos A$ and substitute:

$$\begin{aligned} a^2 &= b^2 + c^2 - 2bc \cos A \\ 32^2 &\approx 71^2 + 48^2 - 2 \cdot 71 \cdot 48 \cos A && \text{Substituting} \\ 1024 &\approx 5041 + 2304 - 6816 \cos A \\ -6321 &\approx -6816 \cos A \\ \cos A &\approx 0.9273768 \\ A &\approx 22.0^\circ. \end{aligned}$$

The third angle is now easy to find:

$$\begin{aligned} C &\approx 180^\circ - (125.2^\circ + 22.0^\circ) \\ &\approx 32.8^\circ. \end{aligned}$$

Thus,

$$\begin{aligned} A &\approx 22.0^\circ, & a &= 32, \\ B &= 125.2^\circ, & b &\approx 71, \\ C &\approx 32.8^\circ, & c &= 48. \end{aligned}$$

 **Now Try Exercise 1.**

Due to errors created by rounding, answers may vary depending on the order in which they are found. Had we found the measure of angle C first in Example 1, the angle measures would have been $C \approx 34.1^\circ$ and $A \approx 20.7^\circ$. Variances in rounding also change the answers. Had we used 71.4 for b in Example 1, the angle measures would have been $A \approx 21.5^\circ$ and $C \approx 33.3^\circ$.

Suppose we used the law of sines at the outset in Example 1 to find b . We were given only three measures: $a = 32$, $c = 48$, and $B = 125.2^\circ$. When substituting these measures into the proportions, we see that there is not enough information to use the law of sines:

$$\begin{aligned} \frac{a}{\sin A} &= \frac{b}{\sin B} \rightarrow \frac{32}{\sin A} = \frac{b}{\sin 125.2^\circ}, \\ \frac{b}{\sin B} &= \frac{c}{\sin C} \rightarrow \frac{b}{\sin 125.2^\circ} = \frac{48}{\sin C}, \\ \frac{a}{\sin A} &= \frac{c}{\sin C} \rightarrow \frac{32}{\sin A} = \frac{48}{\sin C}. \end{aligned}$$

In all three situations, the resulting equation, after the substitutions, still has two unknowns. Thus we cannot use the law of sines to find b .

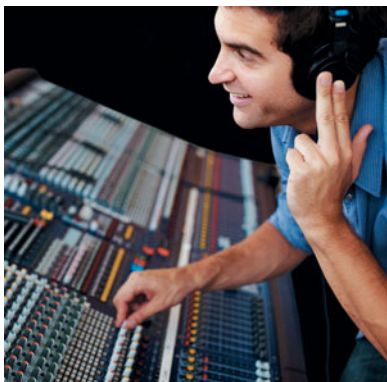

EXAMPLE 2 Recording Studio. A musician is constructing an octagonal recording studio in his home and needs to determine two distances for the electrician. The dimensions for the most acoustically perfect studio are shown in the figure below (Source: Tony Medeiros, Indianapolis, IN). Determine the distances from D to F and from D to B to the nearest tenth of an inch.

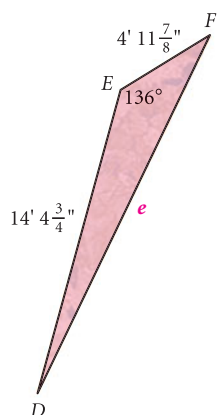
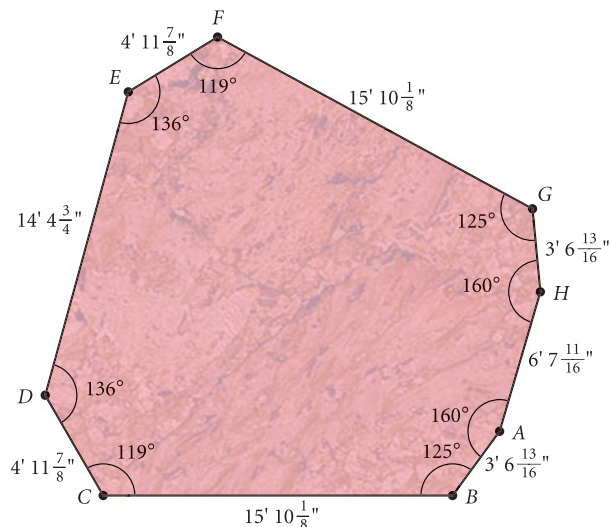

Solution We begin by connecting points D and F and labeling the known measures of $\triangle DEF$. Converting the linear measures to decimal notation in inches, we have

$$d = 4' 11\frac{7}{8}" = 59.875 \text{ in.},$$

$$f = 14' 4\frac{3}{4}" = 172.75 \text{ in.},$$

$$E = 136^\circ.$$

We can find the measure of the third side, e , using the law of cosines:

$$e^2 = d^2 + f^2 - 2 \cdot d \cdot f \cdot \cos E$$

Using the law of cosines

$$e^2 = (59.875 \text{ in.})^2 + (172.75 \text{ in.})^2$$

$$- 2(59.875 \text{ in.})(172.75 \text{ in.}) \cos 136^\circ$$

Substituting

$$e^2 \approx 48,308.4257 \text{ in}^2$$

$$e \approx 219.8 \text{ in.}$$

Thus it is approximately 219.8 in. from D to F .

We continue by connecting points D and B and labeling the known measures of $\triangle DCB$:

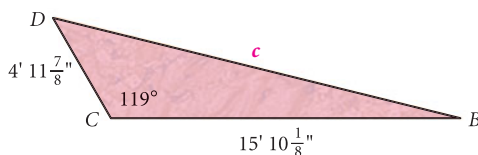

$$b = 4' 11\frac{7}{8}" = 59.875 \text{ in.},$$

$$d = 15' 10\frac{1}{8}" = 190.125 \text{ in.},$$

$$C = 119^\circ.$$

Using the law of cosines, we can determine c , the length of the third side:

$$\begin{aligned} c^2 &= b^2 + d^2 - 2 \cdot b \cdot d \cdot \cos C && \text{Using the law of} \\ c^2 &= (59.875 \text{ in.})^2 + (190.125 \text{ in.})^2 && \text{cosines} \\ &\quad - 2(59.875 \text{ in.})(190.125 \text{ in.}) \cos 119^\circ && \text{Substituting} \\ c^2 &\approx 50,770.4191 \text{ in}^2 \\ c &\approx 225.3 \text{ in.} \end{aligned}$$

The distance from D to B is approximately 225.3 in.

 Now Try Exercise 25.

► Solving Triangles (SSS)

When all three sides of a triangle are known, the law of cosines can be used to solve the triangle.

EXAMPLE 3 Solve $\triangle RST$ if $r = 3.5$, $s = 4.7$, and $t = 2.8$.

Solution We sketch a triangle and label it with the given measures:

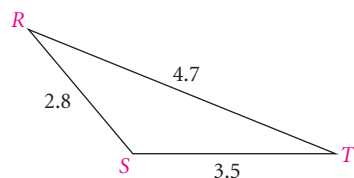

$$\begin{aligned} R &= ?, & r &= 3.5, \\ S &= ?, & s &= 4.7, \\ T &= ?, & t &= 2.8. \end{aligned}$$

Since we do not know any of the angle measures, we cannot use the law of sines. We begin instead by finding an angle with the law of cosines. We choose to find S first and select the formula that contains $\cos S$:

$$\begin{aligned} s^2 &= r^2 + t^2 - 2rt \cos S \\ (4.7)^2 &= (3.5)^2 + (2.8)^2 - 2(3.5)(2.8) \cos S && \text{Substituting} \\ \cos S &= \frac{(3.5)^2 + (2.8)^2 - (4.7)^2}{2(3.5)(2.8)} \\ \cos S &\approx -0.1020408 \\ S &\approx 95.86^\circ. \end{aligned}$$

Similarly, we find angle R :

$$\begin{aligned} r^2 &= s^2 + t^2 - 2st \cos R \\ (3.5)^2 &= (4.7)^2 + (2.8)^2 - 2(4.7)(2.8) \cos R \\ \cos R &= \frac{(4.7)^2 + (2.8)^2 - (3.5)^2}{2(4.7)(2.8)} \\ \cos R &\approx 0.6717325 \\ R &\approx 47.80^\circ. \end{aligned}$$

Then

$$T \approx 180^\circ - (95.86^\circ + 47.80^\circ) \approx 36.34^\circ.$$

Thus,

$$R \approx 47.80^\circ, \quad r = 3.5,$$

$$S \approx 95.86^\circ, \quad s = 4.7,$$

$$T \approx 36.34^\circ, \quad t = 2.8.$$

➔ Now Try Exercise 3.

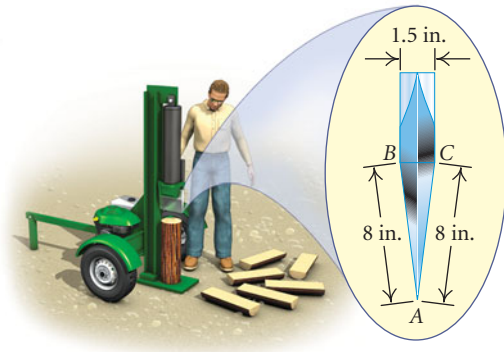

EXAMPLE 4 *Wedge Bevel.* The *bevel* of the wedge (the angle formed at the cutting edge of the wedge) of a log splitter determines the cutting characteristics of the splitter. A small bevel like that of a straight razor makes for a keen edge, but is impractical for heavy-duty cutting because the edge dulls quickly and is prone to chipping. A large bevel is suitable for heavy-duty work like chopping wood. The diagram at left illustrates the wedge of a Huskee log splitter (Source: Huskee). What is its bevel?

Solution Since we know three sides of a triangle, we can use the law of cosines to find the bevel, angle A :

$$a^2 = b^2 + c^2 - 2bc \cos A$$

$$(1.5)^2 = 8^2 + 8^2 - 2 \cdot 8 \cdot 8 \cdot \cos A$$

$$2.25 = 64 + 64 - 128 \cos A$$

$$\cos A = \frac{64 + 64 - 2.25}{128}$$

$$\cos A \approx 0.9824$$

$$A \approx 10.77^\circ.$$

Thus the bevel is approximately 10.77° .

➔ Now Try Exercise 29.

➔ CONNECTING THE CONCEPTS

Choosing the Appropriate Law

The following summarizes the situations in which to use the law of sines and the law of cosines.

To solve an oblique triangle:

Use the *law of sines* for:

AAS
ASA
SSA

Use the *law of cosines* for:

SAS
SSS

The law of cosines can also be used for the SSA situation, but since the process involves solving a quadratic equation, we do not include that option in the list above.

EXAMPLE 5 In $\triangle ABC$, three measures are given. Determine which law to use when solving the triangle. You need not solve the triangle.

- a) $a = 14, b = 23, c = 10$
- b) $a = 207, B = 43.8^\circ, C = 57.6^\circ$
- c) $A = 112^\circ, C = 37^\circ, a = 84.7$
- d) $B = 101^\circ, a = 960, c = 1042$
- e) $b = 17.26, a = 27.29, A = 39^\circ$
- f) $A = 61^\circ, B = 39^\circ, C = 80^\circ$

Solution It is helpful to make a drawing of a triangle with the given information. The triangle need not be drawn to scale. The given parts are shown in color.

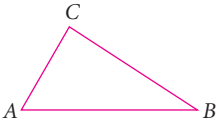
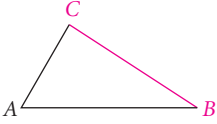
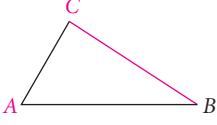
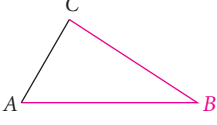
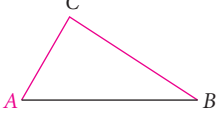
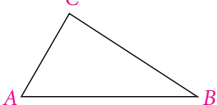
FIGURE	SITUATION	LAW TO USE
a) 	SSS	Law of Cosines
b) 	ASA	Law of Sines
c) 	AAS	Law of Sines
d) 	SAS	Law of Cosines
e) 	SSA	Law of Sines
f) 	AAA	Cannot be solved

 Now Try Exercises 17 and 19.

8.2 Exercise Set

Solve the triangle, if possible.

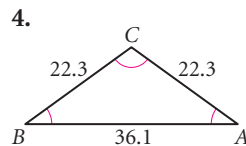
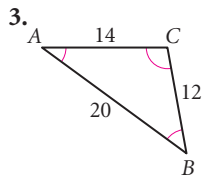
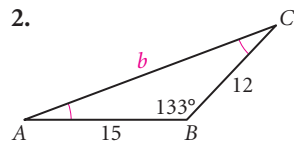
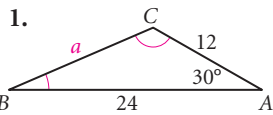

5. $B = 72^\circ 40'$, $c = 16$ m, $a = 78$ m
6. $C = 22.28^\circ$, $a = 25.4$ cm, $b = 73.8$ cm
7. $a = 16$ m, $b = 20$ m, $c = 32$ m
8. $B = 72.66^\circ$, $a = 23.78$ km, $c = 25.74$ km
9. $a = 2$ ft, $b = 3$ ft, $c = 8$ ft
10. $A = 96^\circ 13'$, $b = 15.8$ yd, $c = 18.4$ yd
11. $a = 26.12$ km, $b = 21.34$ km, $c = 19.25$ km
12. $C = 28^\circ 43'$, $a = 6$ mm, $b = 9$ mm
13. $a = 60.12$ mi, $b = 40.23$ mi, $C = 48.7^\circ$
14. $a = 11.2$ cm, $b = 5.4$ cm, $c = 7$ cm
15. $b = 10.2$ in., $c = 17.3$ in., $A = 53.456^\circ$
16. $a = 17$ yd, $b = 15.4$ yd, $c = 1.5$ yd

Determine which law applies. Then solve the triangle.

17. $A = 70^\circ$, $B = 12^\circ$, $b = 21.4$
18. $a = 15$, $c = 7$, $B = 62^\circ$
19. $a = 3.3$, $b = 2.7$, $c = 2.8$
20. $a = 1.5$, $b = 2.5$, $A = 58^\circ$
21. $A = 40.2^\circ$, $B = 39.8^\circ$, $C = 100^\circ$
22. $a = 60$, $b = 40$, $C = 47^\circ$
23. $a = 3.6$, $b = 6.2$, $c = 4.1$
24. $B = 110^\circ 30'$, $C = 8^\circ 10'$, $c = 0.912$

25. **Fish Attractor.** Each year at Cedar Resort, discarded Christmas trees are collected and sunk in the lake to form a fish attractor. Visitors are told that it is 253 ft from the pier to the fish attractor and 415 ft to another pier across the lake. Using a compass, the fisherman finds that the attractor's azimuth (the direction measured as an angle from north) is 340° and that of the other pier is 35° . What is the distance between the fish attractor and the pier across the lake?

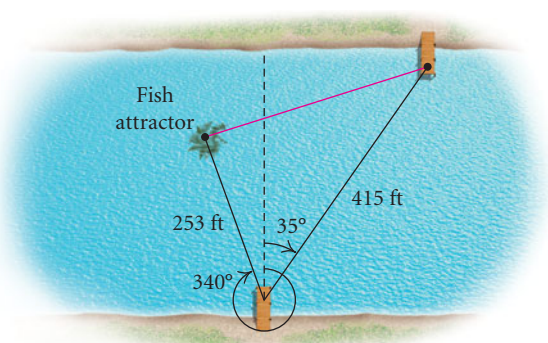

26. **Circus Highwire Act.** A circus highwire act walks up an approach wire to reach a highwire. The approach wire is 122 ft long and is currently anchored so that it forms the maximum allowable angle of 35° with the ground. A greater approach angle causes the aerialists to slip. However, the aerialists find that there is enough room to anchor the approach wire 30 ft back in order to make the approach angle less severe. When this is done, how much farther will they have to walk up the approach wire, and what will the new approach angle be?

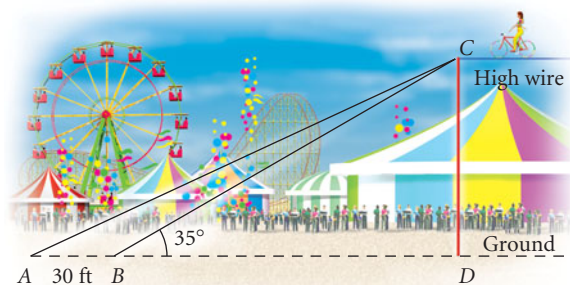

27. **In-line Skater.** An in-line skater skates on a fitness trail along the Pacific Ocean from point A to point B . As shown below, two streets intersecting at point C also intersect the trail at A and B . In her car, the skater found the lengths of AC and BC to be approximately 0.5 mi and 1.3 mi, respectively. From a map, she estimates the included angle at C to be 110° . How far did she skate from A to B ?

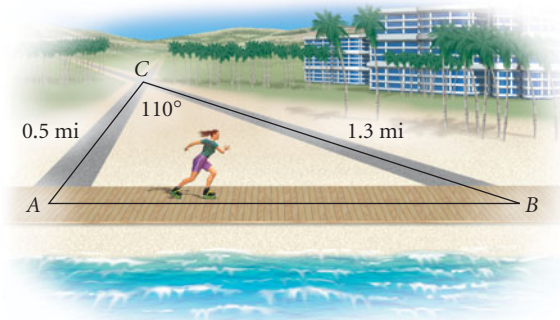

28. **Baseball Bunt.** A batter in a baseball game drops a bunt down the first-base line. It rolls 34 ft at an angle of 25° with the base path. The pitcher's mound is 60.5 ft from home plate. How far must the pitcher travel to pick up the ball? (*Hint:* A baseball diamond is a square.)

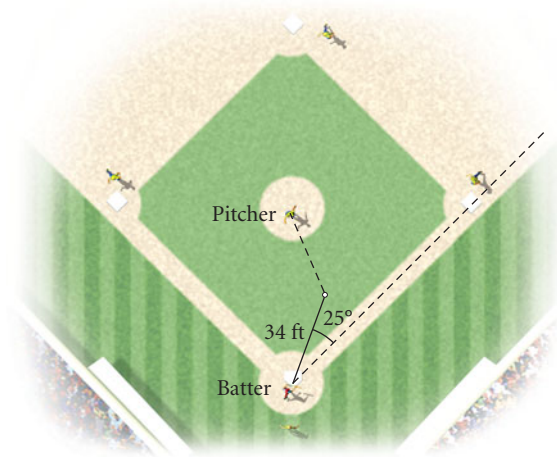

29. **Survival Trip.** A group of college students is learning to navigate for an upcoming survival trip. On a map, they have been given three points at which they are to check in. The map also shows the distances between the points. However, in order to navigate

they need to know the angle measurements. Calculate the angles for them.

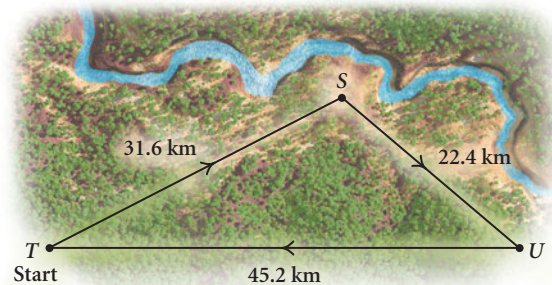

30. **Ships.** Two ships leave harbor at the same time. The first sails $N15^\circ W$ at 25 knots. (A knot is one nautical mile per hour.) The second sails $N32^\circ E$ at 20 knots. After 2 hr, how far apart are the ships?

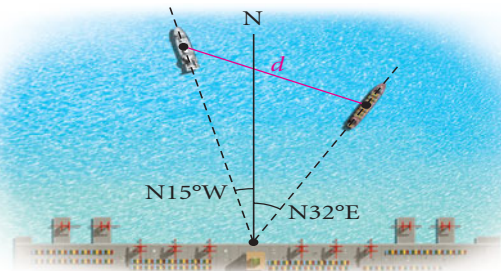

31. **Airplanes.** Two airplanes leave an airport at the same time. The first flies 150 km/h in a direction of 320° . The second flies 200 km/h in a direction of 200° . After 3 hr, how far apart are the planes?
32. **Slow-Pitch Softball.** A slow-pitch softball diamond is a square 65 ft on a side. The pitcher's mound is 46 ft from home plate. How far is it from the pitcher's mound to first base?
33. **Isosceles Trapezoid.** The longer base of an isosceles trapezoid measures 14 ft. The nonparallel sides measure 10 ft, and the base angles measure 80° .
- Find the length of a diagonal.
 - Find the area.
34. **Dimensions of Sail.** A sail that is in the shape of an isosceles triangle has a vertex angle of 38° . The angle is included by two sides, each measuring 20 ft. Find the length of the other side of the sail.

35. Three circles are arranged as shown in the figure below. Find the length PQ .

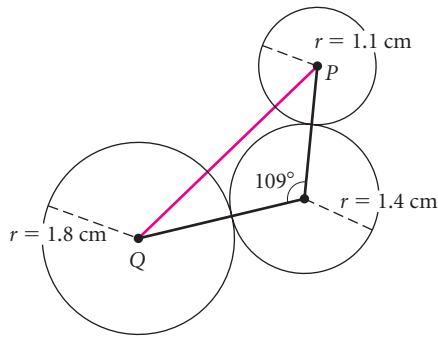

36. **Swimming Pool.** A triangular swimming pool measures 44 ft on one side and 32.8 ft on another side. These sides form an angle that measures 40.8° . How long is the other side?

Skill Maintenance

Classify the function as linear, quadratic, cubic, quartic, rational, exponential, logarithmic, or trigonometric.

37. $f(x) = -\frac{3}{4}x^4$ 38. $y - 3 = 17x$

39. $y = \sin^2 x - 3 \sin x$ 40. $f(x) = 2^{x-1/2}$

41. $f(x) = \frac{x^2 - 2x + 3}{x - 1}$

42. $f(x) = 27 - x^3$

43. $y = e^x + e^{-x} - 4$

44. $y = \log_2(x - 2) - \log_2(x + 3)$

45. $f(x) = -\cos(\pi x - 3)$

46. $y = \frac{1}{2}x^2 - 2x + 2$

Synthesis

47. **Canyon Depth.** A bridge is being built across a canyon. The length of the bridge is 5045 ft. From the deepest point in the canyon, the angles of elevation

of the ends of the bridge are 78° and 72° . How deep is the canyon?

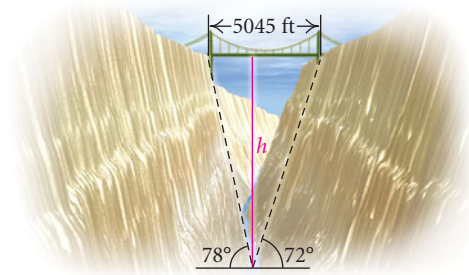

48. **Heron's Formula.** If a , b , and c are the lengths of the sides of a triangle, then the area K of the triangle is given by

$$K = \sqrt{s(s-a)(s-b)(s-c)},$$

where $s = \frac{1}{2}(a + b + c)$. The number s is called the *semiperimeter*. Prove Heron's formula. (*Hint:* Use the area formula $K = \frac{1}{2}bc \sin A$ developed in Section 8.1.) Then use Heron's formula to find the area of the triangular swimming pool described in Exercise 36.

49. **Area of Isosceles Triangle.** Find a formula for the area of an isosceles triangle in terms of the congruent sides and their included angle. Under what conditions will the area of a triangle with fixed congruent sides be maximum?
50. **Reconnaissance Plane.** A reconnaissance plane patrolling at 5000 ft sights a submarine at bearing 35° and at an angle of depression of 25° . A carrier is at bearing 105° and at an angle of depression of 60° . How far is the submarine from the carrier?

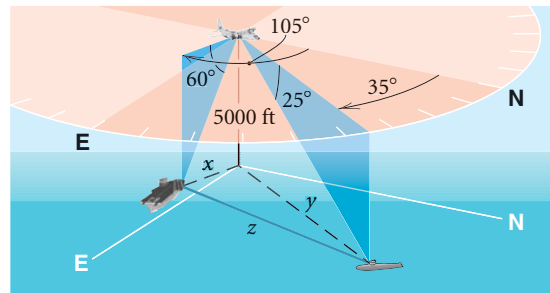

Complex Numbers: Trigonometric Form

8.3

- ▶ Graph complex numbers.
- ▶ Given a complex number in standard form, find trigonometric, or polar, notation; and given a complex number in trigonometric form, find standard notation.
- ▶ Use trigonometric notation to multiply and divide complex numbers.
- ▶ Use DeMoivre's theorem to raise complex numbers to powers.
- ▶ Find the n th roots of a complex number.

▶ Graphical Representation

Just as real numbers can be graphed on a line, complex numbers can be graphed on a plane. We graph a complex number $a + bi$ in the same way that we graph an ordered pair of real numbers (a, b) . However, in place of an x -axis, we have a real axis, and in place of a y -axis, we have an imaginary axis. Horizontal distances correspond to the real part of a number. Vertical distances correspond to the imaginary part.

COMPLEX NUMBERS

REVIEW SECTION 3.1

EXAMPLE 1 Graph each of the following complex numbers.

- a) $3 + 2i$ b) $-4 - 5i$ c) $-3i$
 d) $-1 + 3i$ e) 2

Solution

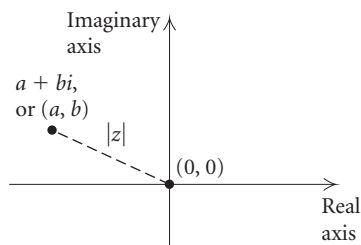
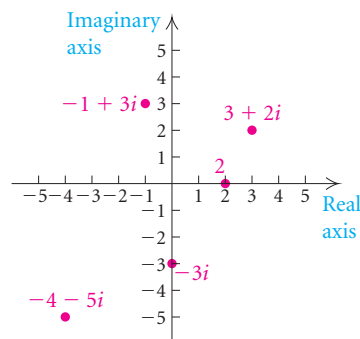

We recall that the absolute value of a real number is its distance from 0 on the number line. The absolute value of a complex number is its distance from the origin in the complex plane. For example, if $z = a + bi$, then using the distance formula, we have

$$|z| = |a + bi| = \sqrt{(a - 0)^2 + (b - 0)^2} = \sqrt{a^2 + b^2}.$$

Absolute Value of a Complex Number

The **absolute value of a complex number** $a + bi$ is

$$|a + bi| = \sqrt{a^2 + b^2}.$$

TECHNOLOGY CONNECTION

We can check our work in Example 2 with a graphing calculator. Note that $\sqrt{5} \approx 2.236067977$ and $\frac{4}{5} = 0.8$.

abs(3+4i)	5
abs(-2-i)	2.236067977
abs(4/5i)	.8

EXAMPLE 2 Find the absolute value of each of the following.

a) $3 + 4i$ b) $-2 - i$ c) $\frac{4}{5}i$

Solution

a) $|3 + 4i| = \sqrt{3^2 + 4^2} = \sqrt{9 + 16} = \sqrt{25} = 5$

b) $|-2 - i| = \sqrt{(-2)^2 + (-1)^2} = \sqrt{5}$

c) $\left|\frac{4}{5}i\right| = \left|0 + \frac{4}{5}i\right| = \sqrt{0^2 + \left(\frac{4}{5}\right)^2} = \frac{4}{5}$

➔ Now Try Exercises 3 and 5.

► Trigonometric Notation for Complex Numbers

Now let's consider a nonzero complex number $a + bi$. Suppose that its absolute value is r . If we let θ be an angle in standard position whose terminal side passes through the point (a, b) , as shown in the figure, then

$$\cos \theta = \frac{a}{r}, \quad \text{or} \quad a = r \cos \theta$$

and

$$\sin \theta = \frac{b}{r}, \quad \text{or} \quad b = r \sin \theta.$$

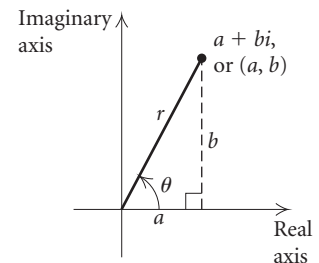

Substituting these values for a and b into the $(a + bi)$ notation, we get

$$\begin{aligned} a + bi &= r \cos \theta + (r \sin \theta)i \\ &= r(\cos \theta + i \sin \theta). \end{aligned}$$

This is **trigonometric notation** for a complex number $a + bi$. The number r is called the **absolute value** of $a + bi$, and θ is called the **argument** of $a + bi$. Trigonometric notation for a complex number is also called **polar notation**.

Trigonometric Notation for Complex Numbers

$$a + bi = r(\cos \theta + i \sin \theta)$$

STUDY TIP

It is never too soon to begin reviewing for the final examination. Take a few minutes each week to read the highlighted (blue-screened boxed) formulas, theorems, and properties. There is also at least one Connecting the Concepts feature in each chapter. Spend time reviewing the organized information and art in this special feature.

In order to find trigonometric notation for a complex number given in **standard notation**, $a + bi$, we must find r and determine the angle θ for which $\sin \theta = b/r$ and $\cos \theta = a/r$.

EXAMPLE 3 Find trigonometric notation for each of the following complex numbers.

a) $1 + i$

b) $\sqrt{3} - i$

Solution

a) We note that $a = 1$ and $b = 1$. Then

$$r = \sqrt{a^2 + b^2} = \sqrt{1^2 + 1^2} = \sqrt{2},$$

$$\sin \theta = \frac{b}{r} = \frac{1}{\sqrt{2}}, \quad \text{or} \quad \frac{\sqrt{2}}{2},$$

and

$$\cos \theta = \frac{a}{r} = \frac{1}{\sqrt{2}}, \quad \text{or} \quad \frac{\sqrt{2}}{2}.$$

Since θ is in quadrant I, $\theta = \pi/4$, or 45° , and we have

$$1 + i = \sqrt{2} \left(\cos \frac{\pi}{4} + i \sin \frac{\pi}{4} \right),$$

or

$$1 + i = \sqrt{2}(\cos 45^\circ + i \sin 45^\circ).$$

b) We see that $a = \sqrt{3}$ and $b = -1$. Then

$$r = \sqrt{(\sqrt{3})^2 + (-1)^2} = 2,$$

$$\sin \theta = \frac{-1}{2} = -\frac{1}{2},$$

and

$$\cos \theta = \frac{\sqrt{3}}{2}.$$

Since θ is in quadrant IV, $\theta = 11\pi/6$, or 330° , and we have

$$\sqrt{3} - i = 2 \left(\cos \frac{11\pi}{6} + i \sin \frac{11\pi}{6} \right),$$

or

$$\sqrt{3} - i = 2(\cos 330^\circ + i \sin 330^\circ).$$

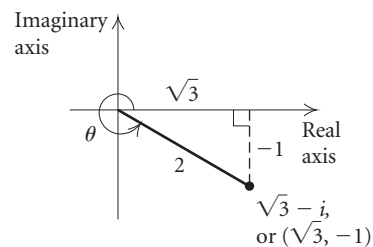
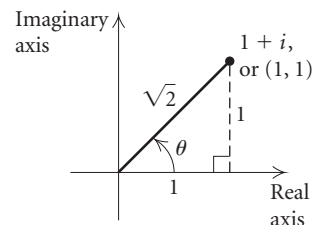

TECHNOLOGY CONNECTION

When finding trigonometric notation for complex numbers, as in Example 3, we can use a graphing calculator to determine angle values in degrees.

angle(1+i)	45
angle(sqrt(3)-i)	-30

Now Try Exercise 13.

In changing to trigonometric notation, note that there are many angles satisfying the given conditions. We ordinarily choose the *smallest positive* angle.

TECHNOLOGY CONNECTION

We can perform the computations in Example 4 on a graphing calculator.

Degree Mode

$$\frac{2(\cos(120) + i\sin(120))}{-1 + 1.732050808i}$$

Radian Mode

$$\frac{\sqrt{8}(\cos(7\pi/4) + i\sin(7\pi/4))}{2 - 2i}$$

To change from trigonometric notation to standard notation, $a + bi$, we recall that $a = r \cos \theta$ and $b = r \sin \theta$.

EXAMPLE 4 Find standard notation, $a + bi$, for each of the following complex numbers.

a) $2(\cos 120^\circ + i \sin 120^\circ)$ b) $\sqrt{8}\left(\cos \frac{7\pi}{4} + i \sin \frac{7\pi}{4}\right)$

Solution

a) Rewriting, we have

$$2(\cos 120^\circ + i \sin 120^\circ) = 2 \cos 120^\circ + (2 \sin 120^\circ)i.$$

Thus,

$$a = 2 \cos 120^\circ = 2 \cdot \left(-\frac{1}{2}\right) = -1$$

and

$$b = 2 \sin 120^\circ = 2 \cdot \left(\frac{\sqrt{3}}{2}\right) = \sqrt{3},$$

so

$$2(\cos 120^\circ + i \sin 120^\circ) = -1 + \sqrt{3}i.$$

b) Rewriting, we have

$$\sqrt{8}\left(\cos \frac{7\pi}{4} + i \sin \frac{7\pi}{4}\right) = \sqrt{8} \cos \frac{7\pi}{4} + \left(\sqrt{8} \sin \frac{7\pi}{4}\right)i.$$

Thus,

$$a = \sqrt{8} \cos \frac{7\pi}{4} = \sqrt{8} \cdot \frac{\sqrt{2}}{2} = 2$$

and

$$b = \sqrt{8} \sin \frac{7\pi}{4} = \sqrt{8} \cdot \left(-\frac{\sqrt{2}}{2}\right) = -2,$$

so

$$\sqrt{8}\left(\cos \frac{7\pi}{4} + i \sin \frac{7\pi}{4}\right) = 2 - 2i.$$

 Now Try Exercises 23 and 27.

► Multiplication and Division with Trigonometric Notation

Multiplication of complex numbers is easier to manage with trigonometric notation than with standard notation. We simply multiply the absolute values and add the arguments. Let's state this in a more formal manner.

Complex Numbers: Multiplication

For any complex numbers $r_1(\cos \theta_1 + i \sin \theta_1)$ and $r_2(\cos \theta_2 + i \sin \theta_2)$,

$$\begin{aligned} r_1(\cos \theta_1 + i \sin \theta_1) \cdot r_2(\cos \theta_2 + i \sin \theta_2) \\ = r_1 r_2 [\cos(\theta_1 + \theta_2) + i \sin(\theta_1 + \theta_2)]. \end{aligned}$$

Proof We have

$$\begin{aligned} r_1(\cos \theta_1 + i \sin \theta_1) \cdot r_2(\cos \theta_2 + i \sin \theta_2) = \\ r_1 r_2 (\cos \theta_1 \cos \theta_2 - \sin \theta_1 \sin \theta_2) + r_1 r_2 (\sin \theta_1 \cos \theta_2 + \cos \theta_1 \sin \theta_2) i. \end{aligned}$$

Now, using identities for sums of angles, we simplify, obtaining

$$r_1 r_2 \cos(\theta_1 + \theta_2) + r_1 r_2 \sin(\theta_1 + \theta_2) i,$$

or

$$r_1 r_2 [\cos(\theta_1 + \theta_2) + i \sin(\theta_1 + \theta_2)],$$

which was to be shown. ■

EXAMPLE 5 Multiply and express the answer to each of the following in standard notation.

a) $3(\cos 40^\circ + i \sin 40^\circ)$ and $4(\cos 20^\circ + i \sin 20^\circ)$

b) $2(\cos \pi + i \sin \pi)$ and $3\left[\cos\left(-\frac{\pi}{2}\right) + i \sin\left(-\frac{\pi}{2}\right)\right]$

Solution

$$\begin{aligned} \text{a) } & 3(\cos 40^\circ + i \sin 40^\circ) \cdot 4(\cos 20^\circ + i \sin 20^\circ) \\ & = 3 \cdot 4 \cdot [\cos(40^\circ + 20^\circ) + i \sin(40^\circ + 20^\circ)] \\ & = 12(\cos 60^\circ + i \sin 60^\circ) \\ & = 12\left(\frac{1}{2} + \frac{\sqrt{3}}{2}i\right) \\ & = 6 + 6\sqrt{3}i \end{aligned}$$

$$\begin{aligned} \text{b) } & 2(\cos \pi + i \sin \pi) \cdot 3\left[\cos\left(-\frac{\pi}{2}\right) + i \sin\left(-\frac{\pi}{2}\right)\right] \\ & = 2 \cdot 3 \cdot \left[\cos\left(\pi + \left(-\frac{\pi}{2}\right)\right) + i \sin\left(\pi + \left(-\frac{\pi}{2}\right)\right)\right] \\ & = 6\left(\cos \frac{\pi}{2} + i \sin \frac{\pi}{2}\right) \\ & = 6(0 + i \cdot 1) \\ & = 6i \end{aligned}$$

TECHNOLOGY CONNECTION

We can multiply complex numbers on a graphing calculator. The products in Example 5 are shown below.

Degree Mode

$$\begin{aligned} & 3(\cos(40) + i\sin(40)) * 4(\cos(20) + \\ & i\sin(20)) \\ & 6 + 10.39230485i \end{aligned}$$

Radian Mode

$$\begin{aligned} & 2(\cos(\pi) + i\sin(\pi)) * 3(\cos(-\pi/2) + \\ & i\sin(-\pi/2)) \\ & 6i \end{aligned}$$



EXAMPLE 6 Convert to trigonometric notation and multiply:

$$(1 + i)(\sqrt{3} - i).$$

Solution We first find trigonometric notation:

$$1 + i = \sqrt{2}(\cos 45^\circ + i \sin 45^\circ), \quad \text{See Example 3(a).}$$

$$\sqrt{3} - i = 2(\cos 330^\circ + i \sin 330^\circ). \quad \text{See Example 3(b).}$$

Then we multiply:

$$\begin{aligned} & \sqrt{2}(\cos 45^\circ + i \sin 45^\circ) \cdot 2(\cos 330^\circ + i \sin 330^\circ) \\ &= 2\sqrt{2}[\cos(45^\circ + 330^\circ) + i \sin(45^\circ + 330^\circ)] \\ &= 2\sqrt{2}(\cos 375^\circ + i \sin 375^\circ) \\ &= 2\sqrt{2}(\cos 15^\circ + i \sin 15^\circ). \quad \text{375^\circ has the same terminal side as 15^\circ.} \end{aligned}$$

 Now Try Exercise 35.

To divide complex numbers, we divide the absolute values and subtract the arguments. We state this fact below, but omit the proof.

Complex Numbers: Division

For any complex numbers $r_1(\cos \theta_1 + i \sin \theta_1)$ and $r_2(\cos \theta_2 + i \sin \theta_2)$, $r_2 \neq 0$,

$$\frac{r_1(\cos \theta_1 + i \sin \theta_1)}{r_2(\cos \theta_2 + i \sin \theta_2)} = \frac{r_1}{r_2}[\cos(\theta_1 - \theta_2) + i \sin(\theta_1 - \theta_2)].$$

EXAMPLE 7 Divide

$$2\left(\cos \frac{3\pi}{2} + i \sin \frac{3\pi}{2}\right) \text{ by } 4\left(\cos \frac{\pi}{2} + i \sin \frac{\pi}{2}\right)$$

and express the solution in standard notation.

Solution We have

$$\begin{aligned} \frac{2\left(\cos \frac{3\pi}{2} + i \sin \frac{3\pi}{2}\right)}{4\left(\cos \frac{\pi}{2} + i \sin \frac{\pi}{2}\right)} &= \frac{2}{4}\left[\cos\left(\frac{3\pi}{2} - \frac{\pi}{2}\right) + i \sin\left(\frac{3\pi}{2} - \frac{\pi}{2}\right)\right] \\ &= \frac{1}{2}(\cos \pi + i \sin \pi) \\ &= \frac{1}{2}(-1 + i \cdot 0) \\ &= -\frac{1}{2}. \end{aligned}$$



EXAMPLE 8 Convert to trigonometric notation and divide:

$$\frac{1 + i}{1 - i}$$

Solution We first convert to trigonometric notation:

$$1 + i = \sqrt{2}(\cos 45^\circ + i \sin 45^\circ), \quad \text{See Example 3(a).}$$

$$1 - i = \sqrt{2}(\cos 315^\circ + i \sin 315^\circ).$$

We now divide:

$$\begin{aligned} & \frac{\sqrt{2}(\cos 45^\circ + i \sin 45^\circ)}{\sqrt{2}(\cos 315^\circ + i \sin 315^\circ)} \\ &= 1[\cos(45^\circ - 315^\circ) + i \sin(45^\circ - 315^\circ)] \\ &= \cos(-270^\circ) + i \sin(-270^\circ) \\ &= 0 + i \cdot 1 \\ &= i. \end{aligned}$$

 **Now Try Exercise 39.**

TECHNOLOGY CONNECTION

We can find quotients, like the one in Example 8, on a graphing calculator.

$$(1 + i)/(1 - i)$$

i

► Powers of Complex Numbers

An important theorem about powers and roots of complex numbers is named for the French mathematician Abraham DeMoivre (1667–1754). Let's consider the square of a complex number $r(\cos \theta + i \sin \theta)$:

$$\begin{aligned} [r(\cos \theta + i \sin \theta)]^2 &= [r(\cos \theta + i \sin \theta)] \cdot [r(\cos \theta + i \sin \theta)] \\ &= r \cdot r \cdot [\cos(\theta + \theta) + i \sin(\theta + \theta)] \\ &= r^2(\cos 2\theta + i \sin 2\theta). \end{aligned}$$

Similarly, we see that

$$\begin{aligned} [r(\cos \theta + i \sin \theta)]^3 &= r \cdot r \cdot r \cdot [\cos(\theta + \theta + \theta) + i \sin(\theta + \theta + \theta)] \\ &= r^3(\cos 3\theta + i \sin 3\theta). \end{aligned}$$

DeMoivre's theorem is the generalization of these results.

DeMoivre's Theorem

For any complex number $r(\cos \theta + i \sin \theta)$ and any natural number n ,

$$[r(\cos \theta + i \sin \theta)]^n = r^n(\cos n\theta + i \sin n\theta).$$

EXAMPLE 9 Find each of the following.

a) $(1 + i)^9$

b) $(\sqrt{3} - i)^{10}$

TECHNOLOGY CONNECTION

We can find powers of complex numbers, like those in Example 9, on a graphing calculator.

$(1+i)^9$	$16+16i$
$(\sqrt{3}-i)^{10}$	$512+886.8100135i$

Solution

a) We first find trigonometric notation:

$$1 + i = \sqrt{2}(\cos 45^\circ + i \sin 45^\circ). \quad \text{See Example 3(a).}$$

Then

$$\begin{aligned} (1 + i)^9 &= [\sqrt{2}(\cos 45^\circ + i \sin 45^\circ)]^9 \\ &= (\sqrt{2})^9 [\cos (9 \cdot 45^\circ) + i \sin (9 \cdot 45^\circ)] && \text{DeMoivre's theorem} \\ &= 2^{9/2}(\cos 405^\circ + i \sin 405^\circ) \\ &= 16\sqrt{2}(\cos 45^\circ + i \sin 45^\circ) && \text{405^\circ has the same terminal side as 45^\circ.} \\ &= 16\sqrt{2}\left(\frac{\sqrt{2}}{2} + i\frac{\sqrt{2}}{2}\right) \\ &= 16 + 16i. \end{aligned}$$

b) We first convert to trigonometric notation:

$$\sqrt{3} - i = 2(\cos 330^\circ + i \sin 330^\circ). \quad \text{See Example 3(b).}$$

Then

$$\begin{aligned} (\sqrt{3} - i)^{10} &= [2(\cos 330^\circ + i \sin 330^\circ)]^{10} \\ &= 2^{10}(\cos 3300^\circ + i \sin 3300^\circ) \\ &= 1024(\cos 60^\circ + i \sin 60^\circ) && \text{3300^\circ has the same terminal side as 60^\circ.} \\ &= 1024\left(\frac{1}{2} + i\frac{\sqrt{3}}{2}\right) \\ &= 512 + 512\sqrt{3}i. \end{aligned}$$

 **Now Try Exercise 47.**

► Roots of Complex Numbers

As we will see, every nonzero complex number has two square roots. A nonzero complex number has three cube roots, four fourth roots, and so on. In general, a nonzero complex number has n different n th roots. They can be found using the formula that we now state but do not prove.

Roots of Complex Numbers

The n th roots of a complex number $r(\cos \theta + i \sin \theta)$, $r \neq 0$, are given by

$$r^{1/n} \left[\cos \left(\frac{\theta}{n} + k \cdot \frac{360^\circ}{n} \right) + i \sin \left(\frac{\theta}{n} + k \cdot \frac{360^\circ}{n} \right) \right],$$

where $k = 0, 1, 2, \dots, n - 1$.

EXAMPLE 10 Find the square roots of $2 + 2\sqrt{3}i$.

Solution We first find trigonometric notation:

$$2 + 2\sqrt{3}i = 4(\cos 60^\circ + i \sin 60^\circ).$$

Then $n = 2$, $1/n = 1/2$, and $k = 0, 1$; and

$$\begin{aligned} & [4(\cos 60^\circ + i \sin 60^\circ)]^{1/2} \\ &= 4^{1/2} \left[\cos \left(\frac{60^\circ}{2} + k \cdot \frac{360^\circ}{2} \right) + i \sin \left(\frac{60^\circ}{2} + k \cdot \frac{360^\circ}{2} \right) \right], \quad k = 0, 1 \\ &= 2[\cos(30^\circ + k \cdot 180^\circ) + i \sin(30^\circ + k \cdot 180^\circ)], \quad k = 0, 1. \end{aligned}$$

Thus the roots are

$$2(\cos 30^\circ + i \sin 30^\circ) \quad \text{for } k = 0$$

and $2(\cos 210^\circ + i \sin 210^\circ)$ for $k = 1$,

or $\sqrt{3} + i$ and $-\sqrt{3} - i$.

 **Now Try Exercise 57.**

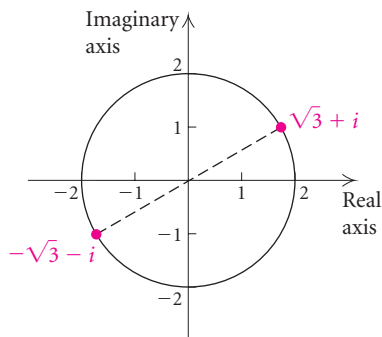

In Example 10, we see that the two square roots of the number are opposites of each other. We can illustrate this graphically. We also note that the roots are equally spaced about a circle of radius r —in this case, $r = 2$. The roots are $360^\circ/2$, or 180° apart.

EXAMPLE 11 Find the cube roots of 1. Then locate them on a graph.

Solution We begin by finding trigonometric notation:

$$1 = 1(\cos 0^\circ + i \sin 0^\circ).$$

Then $n = 3$, $1/n = 1/3$, and $k = 0, 1, 2$; and

$$\begin{aligned} & [1(\cos 0^\circ + i \sin 0^\circ)]^{1/3} \\ &= 1^{1/3} \left[\cos \left(\frac{0^\circ}{3} + k \cdot \frac{360^\circ}{3} \right) + i \sin \left(\frac{0^\circ}{3} + k \cdot \frac{360^\circ}{3} \right) \right], \quad k = 0, 1, 2. \end{aligned}$$

The roots are

$$1(\cos 0^\circ + i \sin 0^\circ), \quad 1(\cos 120^\circ + i \sin 120^\circ),$$

and $1(\cos 240^\circ + i \sin 240^\circ)$,

or 1 , $-\frac{1}{2} + \frac{\sqrt{3}}{2}i$, and $-\frac{1}{2} - \frac{\sqrt{3}}{2}i$.

The graphs of the cube roots lie equally spaced about a circle of radius 1. The roots are $360^\circ/3$, or 120° apart.

 **Now Try Exercise 59.**

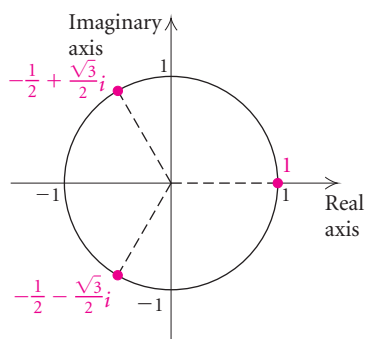

The n th roots of 1 are often referred to as the **n th roots of unity**. In Example 11, we found the cube roots of unity.

TECHNOLOGY CONNECTION

Using a graphing calculator set in PARAMETRIC mode, we can approximate the n th roots of a number p . We use the following window and let

$$X_{1T} = (p^{1/n}) \cos T \quad \text{and} \quad Y_{1T} = (p^{1/n}) \sin T.$$

WINDOW

$$T_{\min} = 0$$

$$T_{\max} = 360, \text{ if in degree mode, or} \\ = 2\pi, \text{ if in radian mode}$$

$$T_{\text{step}} = 360/n, \text{ or } 2\pi/n$$

$$X_{\min} = -3, X_{\max} = 3, X_{\text{scl}} = 1$$

$$Y_{\min} = -2, Y_{\max} = 2, Y_{\text{scl}} = 1$$

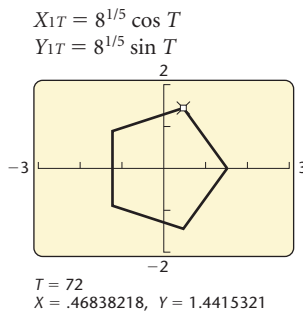

To find the fifth roots of 8, enter $X_{1T} = (8^{1/5}) \cos T$ and $Y_{1T} = (8^{1/5}) \sin T$. In this case, use DEGREE mode. After the graph has been generated, use the TRACE feature to locate the fifth roots. The T , X , and Y values appear on the screen. What do they represent?

Three of the fifth roots of 8 are approximately

$$1.5157, \quad 0.46838 + 1.44153i, \quad \text{and} \quad -1.22624 + 0.89092i.$$

Find the other two. Then use a calculator to approximate the cube roots of unity that were found in Example 11. Also approximate the fourth roots of 5 and the tenth roots of unity.

8.3

Exercise Set

Graph the complex number and find its absolute value.

- $4 + 3i$
- $-2 - 3i$
- i
- $-5 - 2i$
- $4 - i$
- $6 + 3i$
- 3
- $-2i$

Express the indicated number in both standard notation and trigonometric notation.

9.

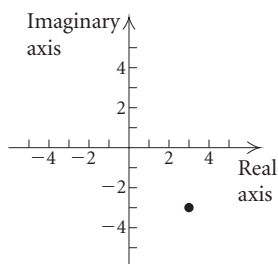

10.

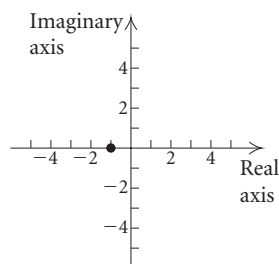

11.

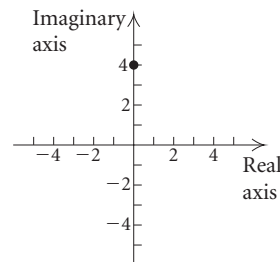

12.

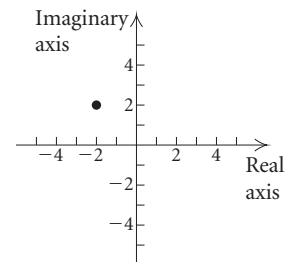

Find trigonometric notation.

- $1 - i$
- $-10\sqrt{3} + 10i$
- $-3i$
- $-5 + 5i$
- $\sqrt{3} + i$
- 4
- $\frac{2}{5}$
- $7.5i$

$$21. -3\sqrt{2} - 3\sqrt{2}i \qquad 22. -\frac{9}{2} - \frac{9\sqrt{3}}{2}i$$

Find standard notation, $a + bi$.

$$23. 3(\cos 30^\circ + i \sin 30^\circ)$$

$$24. 6(\cos 120^\circ + i \sin 120^\circ)$$

$$25. 10(\cos 270^\circ + i \sin 270^\circ)$$

$$26. 3(\cos 0^\circ + i \sin 0^\circ)$$

$$27. \sqrt{8}\left(\cos \frac{\pi}{4} + i \sin \frac{\pi}{4}\right)$$

$$28. 5\left(\cos \frac{\pi}{3} + i \sin \frac{\pi}{3}\right)$$

$$29. 2\left(\cos \frac{\pi}{2} + i \sin \frac{\pi}{2}\right)$$

$$30. 3\left[\cos\left(-\frac{3\pi}{4}\right) + i \sin\left(-\frac{3\pi}{4}\right)\right]$$

$$31. \sqrt{2}[\cos(-60^\circ) + i \sin(-60^\circ)]$$

$$32. 4(\cos 135^\circ + i \sin 135^\circ)$$

Multiply or divide and leave the answer in trigonometric notation.

$$33. \frac{12(\cos 48^\circ + i \sin 48^\circ)}{3(\cos 6^\circ + i \sin 6^\circ)}$$

$$34. 5\left(\cos \frac{\pi}{3} + i \sin \frac{\pi}{3}\right) \cdot 2\left(\cos \frac{\pi}{4} + i \sin \frac{\pi}{4}\right)$$

$$35. 2.5(\cos 35^\circ + i \sin 35^\circ) \cdot 4.5(\cos 21^\circ + i \sin 21^\circ)$$

$$36. \frac{\frac{1}{2}\left(\cos \frac{2\pi}{3} + i \sin \frac{2\pi}{3}\right)}{\frac{3}{8}\left(\cos \frac{\pi}{6} + i \sin \frac{\pi}{6}\right)}$$

Convert to trigonometric notation and then multiply or divide.

$$37. (1 - i)(2 + 2i)$$

$$38. (1 + i\sqrt{3})(1 + i)$$

$$39. \frac{1 - i}{1 + i}$$

$$40. \frac{1 - i}{\sqrt{3} - i}$$

$$41. (3\sqrt{3} - 3i)(2i)$$

$$42. (2\sqrt{3} + 2i)(2i)$$

$$43. \frac{2\sqrt{3} - 2i}{1 + \sqrt{3}i}$$

$$44. \frac{3 - 3\sqrt{3}i}{\sqrt{3} - i}$$

Raise the number to the given power and write trigonometric notation for the answer.

$$45. \left[2\left(\cos \frac{\pi}{3} + i \sin \frac{\pi}{3}\right)\right]^3$$

$$46. [2(\cos 120^\circ + i \sin 120^\circ)]^4$$

$$47. (1 + i)^6$$

$$48. (-\sqrt{3} + i)^5$$

Raise the number to the given power and write standard notation for the answer.

$$49. [3(\cos 20^\circ + i \sin 20^\circ)]^3$$

$$50. [2(\cos 10^\circ + i \sin 10^\circ)]^9$$

$$51. (1 - i)^5$$

$$52. (2 + 2i)^4$$

$$53. \left(\frac{1}{\sqrt{2}} - \frac{1}{\sqrt{2}}i\right)^{12}$$

$$54. \left(\frac{\sqrt{3}}{2} + \frac{1}{2}i\right)^{10}$$

Find the square roots of the number.

$$55. -i$$

$$56. 1 + i$$

$$57. 2\sqrt{2} - 2\sqrt{2}i$$

$$58. -\sqrt{3} - i$$

Find the cube roots of the number.

$$59. i$$

$$60. -64i$$

$$61. 2\sqrt{3} - 2i$$

$$62. 1 - \sqrt{3}i$$

63. Find and graph the fourth roots of 16.

64. Find and graph the fourth roots of i .

65. Find and graph the fifth roots of -1 .

66. Find and graph the sixth roots of 1.

67. Find the tenth roots of 8.

68. Find the ninth roots of -4 .

69. Find the sixth roots of -1 .

70. Find the fourth roots of 12.

Find all the complex solutions of the equation.

$$71. x^3 = 1$$

$$72. x^5 - 1 = 0$$

$$73. x^4 + i = 0$$

$$74. x^4 + 81 = 0$$

$$75. x^6 + 64 = 0$$

$$76. x^5 + \sqrt{3} + i = 0$$

Skill Maintenance

Convert to degree measure.

$$77. \frac{\pi}{12}$$

$$78. 3\pi$$

Convert to radian measure.

79. 330°

80. -225°

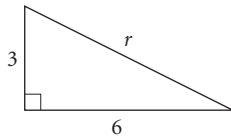
81. Find r .

82. Graph these points in the rectangular coordinate system: $(2, -1)$, $(0, 3)$, and $(-\frac{1}{2}, -4)$.

Find the function value using coordinates of points on the unit circle.

83. $\sin \frac{2\pi}{3}$

84. $\cos \frac{\pi}{6}$

85. $\cos \frac{\pi}{4}$

86. $\sin \frac{5\pi}{6}$

Synthesis

Solve.

87. $x^2 + (1 - i)x + i = 0$

88. $3x^2 + (1 + 2i)x + 1 - i = 0$

89. Find polar notation for $(\cos \theta + i \sin \theta)^{-1}$.90. Show that for any complex number z ,

$$|z| = |-z|.$$

91. Show that for any complex number z and its conjugate \bar{z} ,

$$|z| = |\bar{z}|.$$

(Hint: Let $z = a + bi$ and $\bar{z} = a - bi$.)

92. Show that for any complex number z and its conjugate \bar{z} ,

$$|z\bar{z}| = |z|^2.$$

(Hint: Let $z = a + bi$ and $\bar{z} = a - bi$.)

93. Show that for any complex number z ,

$$|z^2| = |z|^2.$$

94. Show that for any complex numbers z and w ,

$$|z \cdot w| = |z| \cdot |w|.$$

(Hint: Let $z = r_1(\cos \theta_1 + i \sin \theta_1)$ and $w = r_2(\cos \theta_2 + i \sin \theta_2)$.)

95. Show that for any complex number z and any nonzero, complex number w ,

$$\left| \frac{z}{w} \right| = \frac{|z|}{|w|}.$$

(Use the hint for Exercise 94.)

96. On a complex plane, graph $|z| = 1$.97. On a complex plane, graph $z + \bar{z} = 3$.98. Solve: $x^6 - 1 = 0$.

Mid-Chapter Mixed Review

Determine whether the statement is true or false.

- Any triangle, right or oblique, can be solved if at least one side and any other two measures are known. **[8.1]**
- The absolute value of $-i$ is 1. **[8.3]**
- The law of cosines cannot be used to solve a triangle when all three sides are known. **[8.2]**
- Since angle measures determine only the shape of a triangle and not the size, we cannot solve a triangle when only the three angle measures are given. **[8.1]**

Solve $\triangle ABC$, if possible. [8.1], [8.2]

5. $a = 8.3$ in., $A = 52^\circ$, and $C = 65^\circ$

7. $a = 17.8$ yd, $b = 13.1$ yd, and $c = 25.6$ yd

9. $A = 148^\circ$, $b = 200$ yd, and $c = 185$ yd

11. Find the area of the triangle with $C = 54^\circ$, $a = 38$ in., and $b = 29$ in. [8.2]

6. $A = 27.2^\circ$, $c = 33$ m, and $a = 14$ m

8. $a = 29.4$ cm, $b = 40.8$ cm, and $A = 42.7^\circ$

10. $b = 18$ ft, $c = 27$ ft, and $B = 28^\circ$

Graph the complex number and find its absolute value. [8.1]

12. $-5 + 3i$

13. $-i$

14. 4

15. $1 - 5i$

Find trigonometric notation. [8.3]

16. $\frac{\sqrt{2}}{2} + \frac{\sqrt{6}}{2}i$

17. $1 - \sqrt{3}i$

18. $5i$

19. $-2 - 2i$

Find standard notation. [8.3]

20. $2\left(\cos \frac{7\pi}{4} + i \sin \frac{7\pi}{4}\right)$

21. $12(\cos 30^\circ + i \sin 30^\circ)$

22. $\sqrt{5}(\cos 0^\circ + i \sin 0^\circ)$

23. $4\left[\cos\left(-\frac{3\pi}{2}\right) + i \sin\left(-\frac{3\pi}{2}\right)\right]$

Multiply or divide and leave the answer in trigonometric notation. [8.3]

24. $8(\cos 20^\circ + i \sin 20^\circ) \cdot 2(\cos 25^\circ + i \sin 25^\circ)$

25. $3\left(\cos \frac{\pi}{3} + i \sin \frac{\pi}{3}\right) \div \frac{1}{3}\left(\cos \frac{\pi}{4} + i \sin \frac{\pi}{4}\right)$

Convert to trigonometric notation and then multiply or divide. [8.3]

26. $(1 - i)(\sqrt{3} - i)$

27. $\frac{1 - \sqrt{3}i}{1 + i}$

28. Raise $(1 - i)^7$ to the indicated power and write trigonometric notation for the answer. [8.3]

29. Raise $[2(\cos 15^\circ + i \sin 15^\circ)]^4$ to the indicated power and write standard notation for the answer. [8.3]

30. Find the square roots of $-2 - 2\sqrt{3}i$. [8.3]

31. Find the cube roots of -1 . [8.3]

Collaborative Discussion and Writing

32. Try to solve this triangle using the law of cosines. Then explain why it is easier to solve it using the law of sines. [8.2]

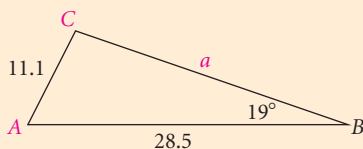

34. Explain why we cannot solve a triangle given SAS with the law of sines. [8.2]

36. Explain why trigonometric notation for a complex number is not unique, but rectangular, or standard, notation is unique. [8.3]

33. Explain why these statements are not contradictory:

The number 1 has one real cube root.

The number 1 has three complex cube roots.

[8.3]

35. Explain why the law of sines cannot be used to find the first angle when solving a triangle given three sides. [8.1]

37. Explain why $x^6 - 2x^3 + 1 = 0$ has 3 distinct solutions, $x^6 - 2x^3 = 0$ has 4 distinct solutions, and $x^6 - 2x = 0$ has 6 distinct solutions. [8.3]

Polar Coordinates and Graphs

8.4

- ▶ Graph points given their polar coordinates.
- ▶ Convert from rectangular coordinates to polar coordinates and from polar coordinates to rectangular coordinates.
- ▶ Convert from rectangular equations to polar equations and from polar equations to rectangular equations.
- ▶ Graph polar equations.

▶ Polar Coordinates

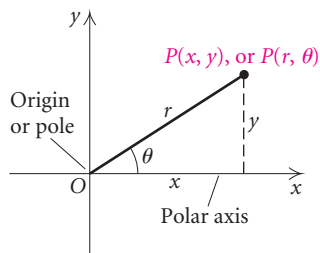

All graphing throughout this text has been done with rectangular coordinates, (x, y) , in the Cartesian coordinate system. We now introduce the polar coordinate system. As shown in the diagram at left, any point P has rectangular coordinates (x, y) and polar coordinates (r, θ) . On a polar graph, the origin is called the **pole**, and the positive half of the x -axis is called the **polar axis**. The point P can be plotted given the directed angle θ from the polar axis to the ray OP and the directed distance r from the pole to the point. The angle θ can be expressed in degrees or radians.

To plot points on a polar graph:

1. Locate the directed angle θ .
2. Move a directed distance r from the pole. If $r > 0$, move along ray OP . If $r < 0$, move in the opposite direction of ray OP .

Polar graph paper, shown below, facilitates plotting. Points B and G illustrate that θ may be in radians. Points E and F illustrate that the polar coordinates of a point are not unique.

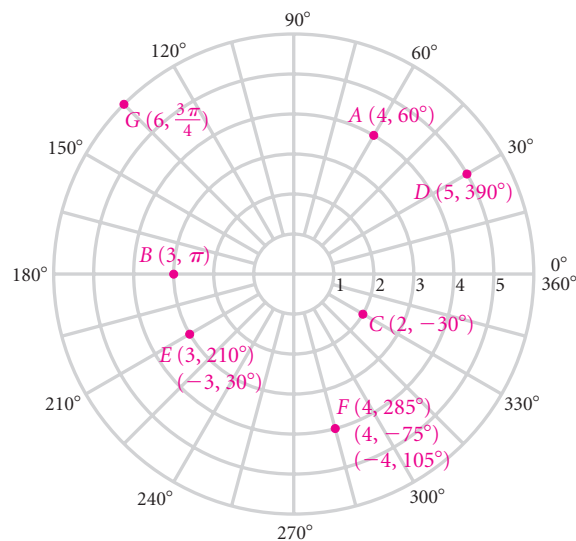

EXAMPLE 1 Graph each of the following points.

- | | |
|--------------------------------------|--------------------------------------|
| a) $A(3, 60^\circ)$ | b) $B(0, 10^\circ)$ |
| c) $C(-5, 120^\circ)$ | d) $D(1, -60^\circ)$ |
| e) $E\left(2, \frac{3\pi}{2}\right)$ | f) $F\left(-4, \frac{\pi}{3}\right)$ |

Solution

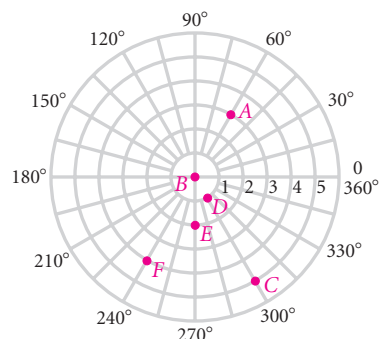

Now Try Exercises 3 and 7.

To convert from rectangular coordinates to polar coordinates and from polar coordinates to rectangular coordinates, we need to recall the following relationships.

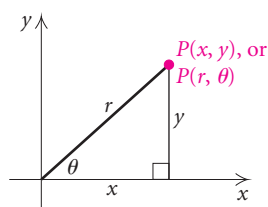

$$r = \sqrt{x^2 + y^2}$$

$$\cos \theta = \frac{x}{r}, \quad \text{or} \quad x = r \cos \theta$$

$$\sin \theta = \frac{y}{r}, \quad \text{or} \quad y = r \sin \theta$$

$$\tan \theta = \frac{y}{x}$$

EXAMPLE 2 Convert each of the following to polar coordinates.

- | | |
|-------------|----------------------|
| a) $(3, 3)$ | b) $(2\sqrt{3}, -2)$ |
|-------------|----------------------|

Solution

a) We first find r :

$$r = \sqrt{3^2 + 3^2} = \sqrt{18} = 3\sqrt{2}.$$

Then we determine θ :

$$\tan \theta = \frac{3}{3} = 1; \quad \text{therefore,} \quad \theta = 45^\circ, \text{ or } \frac{\pi}{4}.$$

We know that for $r = 3\sqrt{2}$, $\theta = \pi/4$ and not $5\pi/4$ since $(3, 3)$ is in quadrant I. Thus, $(r, \theta) = (3\sqrt{2}, 45^\circ)$, or $(3\sqrt{2}, \pi/4)$. Other possibilities for polar coordinates include $(3\sqrt{2}, -315^\circ)$ and $(-3\sqrt{2}, 5\pi/4)$.

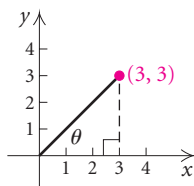

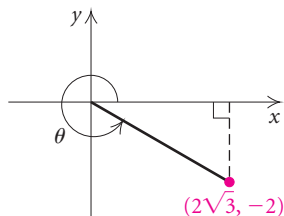

b) We first find r :

$$r = \sqrt{(2\sqrt{3})^2 + (-2)^2} = \sqrt{12 + 4} = \sqrt{16} = 4.$$

Then we determine θ :

$$\tan \theta = \frac{-2}{2\sqrt{3}} = -\frac{1}{\sqrt{3}}; \text{ therefore, } \theta = 330^\circ, \text{ or } \frac{11\pi}{6}.$$

Thus, $(r, \theta) = (4, 330^\circ)$, or $(4, 11\pi/6)$. Other possibilities for polar coordinates for this point include $(4, -\pi/6)$ and $(-4, 150^\circ)$.

Now Try Exercise 19.

It is easier to convert from polar coordinates to rectangular coordinates than from rectangular coordinates to polar coordinates.

EXAMPLE 3 Convert each of the following to rectangular coordinates.

a) $\left(10, \frac{\pi}{3}\right)$

b) $(-5, 135^\circ)$

Solution

a) The ordered pair $(10, \pi/3)$ gives us $r = 10$ and $\theta = \pi/3$. We now find x and y :

$$x = r \cos \theta = 10 \cos \frac{\pi}{3} = 10 \cdot \frac{1}{2} = 5$$

and

$$y = r \sin \theta = 10 \sin \frac{\pi}{3} = 10 \cdot \frac{\sqrt{3}}{2} = 5\sqrt{3}.$$

Thus, $(x, y) = (5, 5\sqrt{3})$.

b) From the ordered pair $(-5, 135^\circ)$, we know that $r = -5$ and $\theta = 135^\circ$. We now find x and y :

$$x = -5 \cos 135^\circ = -5 \cdot \left(-\frac{\sqrt{2}}{2}\right) = \frac{5\sqrt{2}}{2}$$

and

$$y = -5 \sin 135^\circ = -5 \cdot \left(\frac{\sqrt{2}}{2}\right) = -\frac{5\sqrt{2}}{2}.$$

Thus, $(x, y) = \left(\frac{5\sqrt{2}}{2}, -\frac{5\sqrt{2}}{2}\right)$.

Now Try Exercises 31 and 37.

Polar Equations and Rectangular Equations

Some curves have simpler equations in polar coordinates than in rectangular coordinates. For others, the reverse is true.

EXAMPLE 4 Convert each of the following to a polar equation.

a) $x^2 + y^2 = 25$

b) $2x - y = 5$

Solution

a) We have

$$\begin{aligned} x^2 + y^2 &= 25 \\ (r \cos \theta)^2 + (r \sin \theta)^2 &= 25 && \text{Substituting for } x \text{ and } y \\ r^2 \cos^2 \theta + r^2 \sin^2 \theta &= 25 \\ r^2(\cos^2 \theta + \sin^2 \theta) &= 25 \\ r^2 &= 25 && \cos^2 \theta + \sin^2 \theta = 1 \\ r &= 5. \end{aligned}$$

This example illustrates that the polar equation of a circle centered at the origin is much simpler than the rectangular equation.

b) We have

$$\begin{aligned} 2x - y &= 5 \\ 2(r \cos \theta) - (r \sin \theta) &= 5 \\ r(2 \cos \theta - \sin \theta) &= 5. \end{aligned}$$

In this example, we see that the rectangular equation is simpler than the polar equation.

 **Now Try Exercises 39 and 43.**

EXAMPLE 5 Convert each of the following to a rectangular equation.

a) $r = 4$

b) $r \cos \theta = 6$

c) $r = 2 \cos \theta + 3 \sin \theta$

Solution

a) We have

$$\begin{aligned} r &= 4 \\ \sqrt{x^2 + y^2} &= 4 && \text{Substituting for } r \\ x^2 + y^2 &= 16. && \text{Squaring} \end{aligned}$$

In squaring, we must be careful not to introduce solutions of the equation that are not already present. In this case, we did not, because the graph of either equation is a circle of radius 4 centered at the origin.

b) We have

$$\begin{aligned} r \cos \theta &= 6 \\ x &= 6. && x = r \cos \theta \end{aligned}$$

The graph of $r \cos \theta = 6$, or $x = 6$, is a vertical line.

c) We have

$$\begin{aligned} r &= 2 \cos \theta + 3 \sin \theta \\ r^2 &= 2r \cos \theta + 3r \sin \theta && \text{Multiplying by } r \text{ on both sides} \\ x^2 + y^2 &= 2x + 3y. && \text{Substituting } x^2 + y^2 \text{ for } r^2, \\ &&& x \text{ for } r \cos \theta, \text{ and } y \text{ for } r \sin \theta \end{aligned}$$

 **Now Try Exercises 51 and 55.**

► Graphing Polar Equations

To graph a polar equation, we can make a table of values, choosing values of θ and calculating corresponding values of r . We plot the points and complete the graph, as we do when graphing a rectangular equation. A difference occurs in the case of a polar equation, however, because as θ increases sufficiently, points may begin to repeat and the curve will be traced again and again. When this happens, the curve is complete.

EXAMPLE 6 Graph: $r = 1 - \sin \theta$.

Solution We first make a table of values. Note that the points begin to repeat at $\theta = 360^\circ$. We plot these points and draw the curve, as shown below.

θ	r
0°	1
15°	0.7412
30°	0.5
45°	0.2929
60°	0.1340
75°	0.0341
90°	0
105°	0.0341
120°	0.1340
135°	0.2929
150°	0.5
165°	0.7412
180°	1

θ	r
195°	1.2588
210°	1.5
225°	1.7071
240°	1.8660
255°	1.9659
270°	2
285°	1.9659
300°	1.8660
315°	1.7071
330°	1.5
345°	1.2588
360°	1
375°	0.7412
390°	0.5

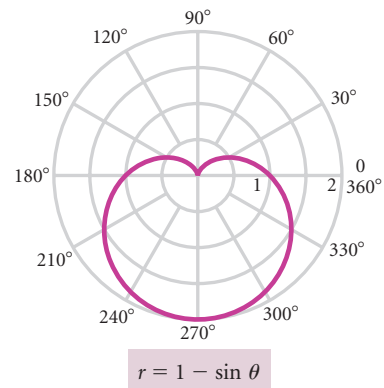

Because of its heart shape, this curve is called a *cardioid*.

➔ **Now Try Exercise 69.**

TECHNOLOGY CONNECTION

We plotted points in Example 6 because we feel that it is important to understand how these curves are developed. We also can graph polar equations using a graphing calculator. The equation usually must be written first in the form $r = f(\theta)$. It is necessary to decide on not only the best window dimensions but also the range of values for θ . Typically, we begin with a range of 0 to 2π for θ in radians and 0° to 360° for θ in degrees. Because most polar graphs are curved, it is important to square the window to minimize distortion.

Graph $r = 4 \sin 3\theta$. Begin by setting the calculator in POLAR mode, and use either of the following windows:

WINDOW
(Radians)

$$\begin{aligned}\theta_{\min} &= 0 \\ \theta_{\max} &= 2\pi \\ \theta_{\text{step}} &= \pi/24 \\ X_{\min} &= -9 \\ X_{\max} &= 9 \\ X_{\text{scl}} &= 1 \\ Y_{\min} &= -6 \\ Y_{\max} &= 6 \\ Y_{\text{scl}} &= 1\end{aligned}$$

WINDOW
(Degrees)

$$\begin{aligned}\theta_{\min} &= 0 \\ \theta_{\max} &= 360 \\ \theta_{\text{step}} &= 1 \\ X_{\min} &= -9 \\ X_{\max} &= 9 \\ X_{\text{scl}} &= 1 \\ Y_{\min} &= -6 \\ Y_{\max} &= 6 \\ Y_{\text{scl}} &= 1\end{aligned}$$

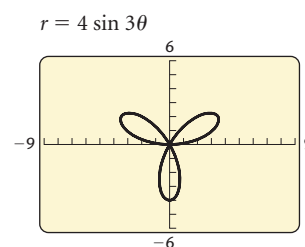

We observe the same graph in both windows. The calculator allows us to view the curve as it is formed.

Now graph each of the following equations and note the effect of changing the coefficient of $\sin 3\theta$ and the coefficient of θ :

$$\begin{aligned}r &= 2 \sin 3\theta, & r &= 6 \sin 3\theta, & r &= 4 \sin \theta, \\ r &= 4 \sin 5\theta, & r &= 4 \sin 2\theta, & r &= 4 \sin 4\theta.\end{aligned}$$

Polar equations of the form $r = a \cos n\theta$ and $r = a \sin n\theta$ have rose-shaped curves. The number a determines the length of the petals, and the number n determines the number of petals. If n is odd, there are n petals. If n is even, there are $2n$ petals.

EXAMPLE 7 Graph each of the following polar equations. Try to visualize the shape of the curve before graphing it.

- $r = 3$
- $r = 5 \sin \theta$
- $r = 2 \csc \theta$

Solution For each graph, we can begin with a table of values. Then we plot points and complete the graph.

a) $r = 3$

For all values of θ , r is 3. Thus the graph of $r = 3$ is a circle of radius 3 centered at the origin.

θ	r
0°	3
60°	3
135°	3
210°	3
300°	3
360°	3

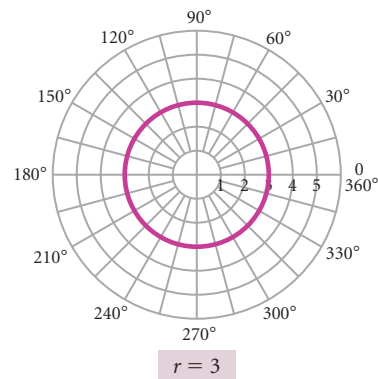

We can verify our graph by converting to the equivalent rectangular equation. For $r = 3$, we substitute $\sqrt{x^2 + y^2}$ for r and square. The resulting equation,

$$x^2 + y^2 = 3^2,$$

is the equation of a circle with radius 3 centered at the origin.

b) $r = 5 \sin \theta$

θ	r
0°	0
15°	1.2941
30°	2.5
45°	3.5355
60°	4.3301
75°	4.8296
90°	5
105°	4.8296
120°	4.3301
135°	3.5355
150°	2.5
165°	1.2941
180°	0

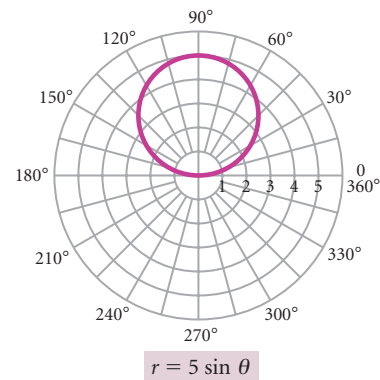

c) $r = 2 \csc \theta$

We can rewrite $r = 2 \csc \theta$ as $r = 2/\sin \theta$.

θ	r
0°	Not defined
15°	7.7274
30°	4
45°	2.8284
60°	2.3094
75°	2.0706
90°	2
105°	2.0706
120°	2.3094
135°	2.8284
150°	4
165°	7.7274
180°	Not defined

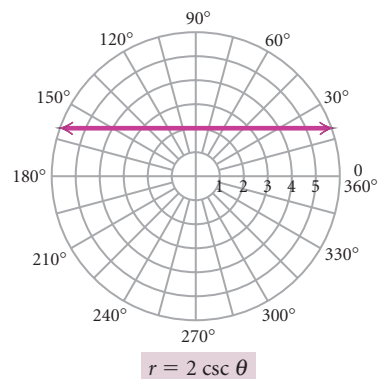

➔ Now Try Exercise 63.

We can check our graph in Example 7(c) by converting the polar equation to the equivalent rectangular equation:

$$r = 2 \csc \theta$$

$$r = \frac{2}{\sin \theta}$$

$$r \sin \theta = 2$$

$$y = 2. \quad \text{Substituting } y \text{ for } r \sin \theta$$

The graph of $y = 2$ is a horizontal line passing through $(0, 2)$ on a rectangular grid.

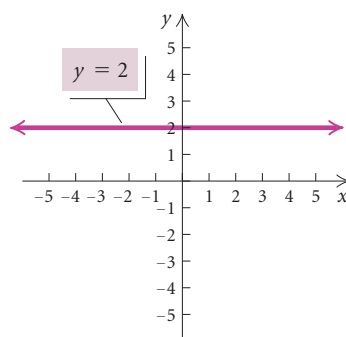

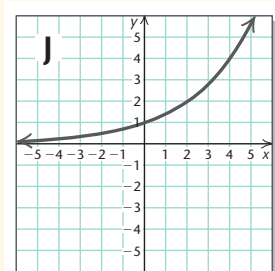
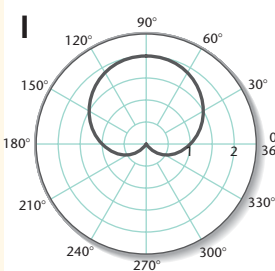
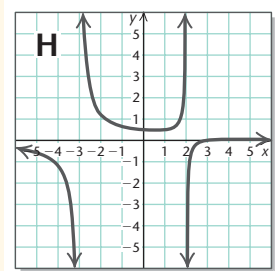
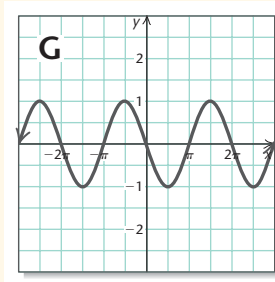
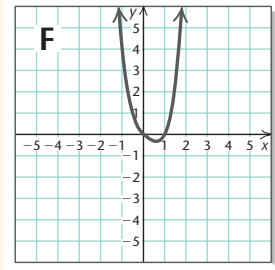
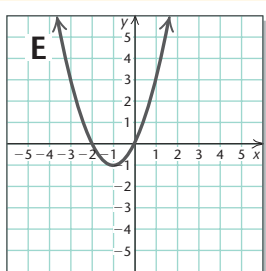
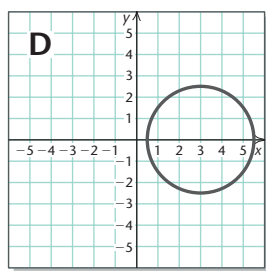
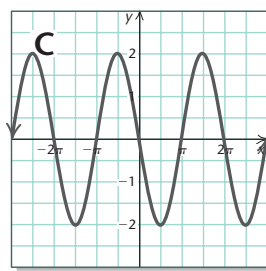
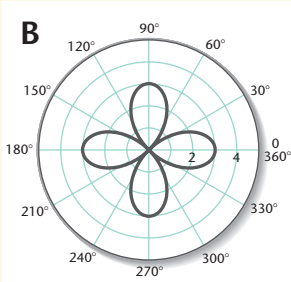
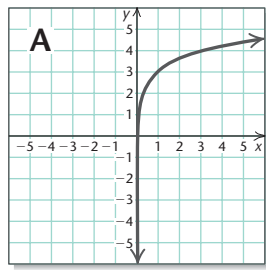

Visualizing the Graph

Match the equation with its graph.

1. $f(x) = 2^{(1/2)x}$
2. $y = -2 \sin x$
3. $y = (x + 1)^2 - 1$
4. $f(x) = \frac{x - 3}{x^2 + x - 6}$
5. $r = 1 + \sin \theta$
6. $f(x) = 2 \log x + 3$
7. $(x - 3)^2 + y^2 = \frac{25}{4}$
8. $y = -\cos\left(x - \frac{\pi}{2}\right)$
9. $r = 3 \cos 2\theta$
10. $f(x) = x^4 - x^3 + x^2 - x$

Answers on page A-53

8.4

Exercise Set

Graph the point on a polar grid.

- $(2, 45^\circ)$
- $(4, \pi)$
- $(3.5, 210^\circ)$
- $(-3, 135^\circ)$
- $(1, \frac{\pi}{6})$
- $(2.75, 150^\circ)$
- $(-5, \frac{\pi}{2})$
- $(0, 15^\circ)$
- $(3, -315^\circ)$
- $(1.2, -\frac{2\pi}{3})$
- $(4.3, -60^\circ)$
- $(3, 405^\circ)$

Find polar coordinates of points A, B, C, and D. Give three answers for each point.

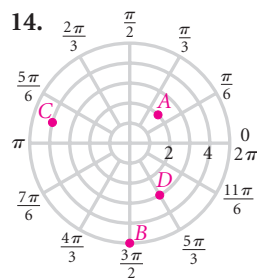
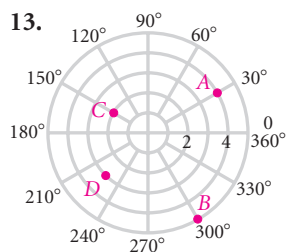

Find the polar coordinates of the point. Express the angle in degrees and then in radians, using the smallest possible positive angle.

- $(0, -3)$
- $(-4, 4)$
- $(3, -3\sqrt{3})$
- $(-\sqrt{3}, 1)$
- $(4\sqrt{3}, -4)$
- $(2\sqrt{3}, 2)$
- $(-\sqrt{2}, -\sqrt{2})$
- $(-3, 3\sqrt{3})$
- $(1, \sqrt{3})$
- $(0, -1)$
- $(\frac{5\sqrt{2}}{2}, -\frac{5\sqrt{2}}{2})$
- $(-\frac{3}{2}, -\frac{3\sqrt{3}}{2})$

Find the rectangular coordinates of the point.

- $(5, 60^\circ)$
- $(0, -23^\circ)$
- $(-3, 45^\circ)$
- $(6, 30^\circ)$

31. $(3, -120^\circ)$

33. $(-2, \frac{5\pi}{3})$

35. $(2, 210^\circ)$

37. $(-6, \frac{5\pi}{6})$

32. $(7, \frac{\pi}{6})$

34. $(1.4, 225^\circ)$

36. $(1, \frac{7\pi}{4})$

38. $(4, 180^\circ)$

Convert to a polar equation.

39. $3x + 4y = 5$

41. $x = 5$

43. $x^2 + y^2 = 36$

45. $x^2 = 25y$

47. $y^2 - 5x - 25 = 0$

49. $x^2 - 2x + y^2 = 0$

40. $5x + 3y = 4$

42. $y = 4$

44. $x^2 - 4y^2 = 4$

46. $2x - 9y + 3 = 0$

48. $x^2 + y^2 = 8y$

50. $3x^2y = 81$

Convert to a rectangular equation.

51. $r = 5$

53. $r \sin \theta = 2$

55. $r + r \cos \theta = 3$

57. $r - 9 \cos \theta = 7 \sin \theta$

58. $r + 5 \sin \theta = 7 \cos \theta$

59. $r = 5 \sec \theta$

61. $\theta = \frac{5\pi}{3}$

Graph the equation.

63. $r = \sin \theta$

65. $r = 4 \cos 2\theta$

67. $r = \cos \theta$

69. $r = 2 - \cos 3\theta$

52. $\theta = \frac{3\pi}{4}$

54. $r = -3 \sin \theta$

56. $r = \frac{2}{1 - \sin \theta}$

60. $r = 3 \cos \theta$

62. $r = \cos \theta - \sin \theta$

64. $r = 1 - \cos \theta$

66. $r = 1 - 2 \sin \theta$

68. $r = 2 \sec \theta$

70. $r = \frac{1}{1 + \cos \theta}$

Skill Maintenance

Solve.

71. $2x - 4 = x + 8$

72. $4 - 5y = 3$

Graph.

73. $y = 2x - 5$

74. $4x - y = 6$

75. $x = -3$

76. $y = 0$

Synthesis

In Exercises 77–88, match the equation with one of figures (a)–(l), which follow.

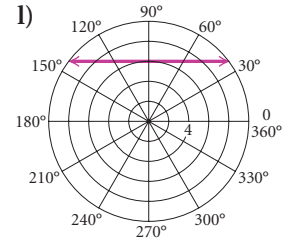
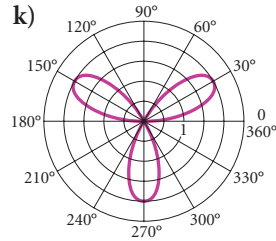
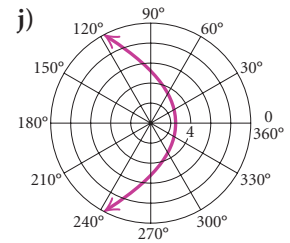
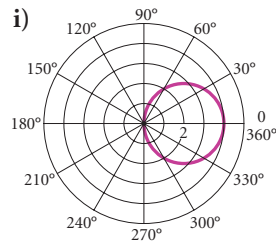
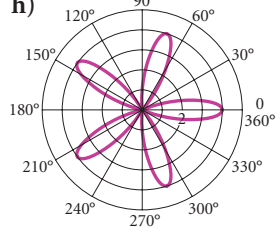
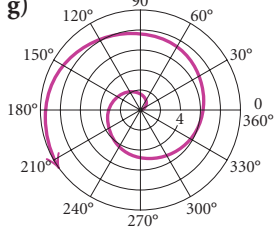
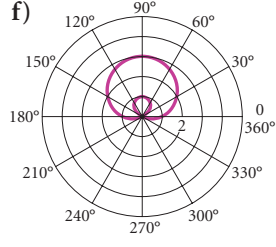
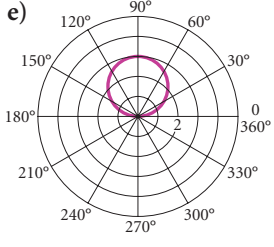
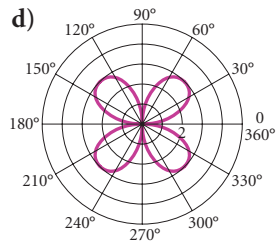
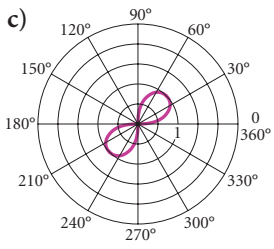
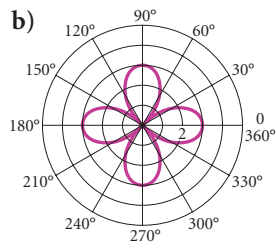
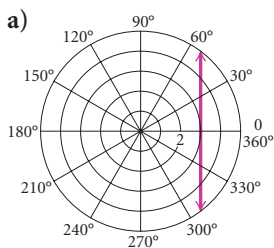

77. $r = 3 \sin 2\theta$

78. $r = 4 \cos \theta$

79. $r = \theta$

80. $r^2 = \sin 2\theta$

81. $r = \frac{5}{1 + \cos \theta}$

82. $r = 1 + 2 \sin \theta$

83. $r = 3 \cos 2\theta$

84. $r = 3 \sec \theta$

85. $r = 3 \sin \theta$

86. $r = 4 \cos 5\theta$

87. $r = 2 \sin 3\theta$

88. $r \sin \theta = 6$

89. Convert to a rectangular equation:

$$r = \sec^2 \frac{\theta}{2}$$

90. The center of a regular hexagon is at the origin, and one vertex is the point $(4, 0^\circ)$. Find the coordinates of the other vertices.

Vectors and Applications

8.5

- ▶ Determine whether two vectors are equivalent.
- ▶ Find the sum, or resultant, of two vectors.
- ▶ Resolve a vector into its horizontal and vertical components.
- ▶ Solve applied problems involving vectors.

We measure some quantities using only their magnitudes. For example, we describe time, length, and mass using units like seconds, feet, and kilograms, respectively. However, to measure quantities like **displacement**, **velocity**, or **force**, we need to describe a *magnitude* and a *direction*. Together magnitude and direction describe a **vector**. The following are some examples.

Displacement. An object moves a certain distance in a certain direction.

A surveyor steps 20 yd to the northeast.

A hiker follows a trail 5 mi to the west.

A batter hits a ball 100 m along the left-field line.

Velocity. An object travels at a certain speed in a certain direction.

A breeze is blowing 15 mph from the northwest.

An airplane is traveling 450 km/h in a direction of 243° .

Force. A push or pull is exerted on an object in a certain direction.

A force of 200 lb is required to pull a cart up a 30° incline.

A 25-lb force is required to lift a box upward.

A force of 15 newtons is exerted downward on the handle of a jack. (A newton, abbreviated N, is a unit of force used in physics, and $1 \text{ N} \approx 0.22 \text{ lb}$.)

▶ Vectors

Vectors can be graphically represented by directed line segments. The length is chosen, according to some scale, to represent the **magnitude of the vector**, and the direction of the directed line segment represents the **direction of the vector**. For example, if we let 1 cm represent 5 km/h, then a 15-km/h wind from the northwest would be represented by a directed line segment 3 cm long, as shown in the figure at left.

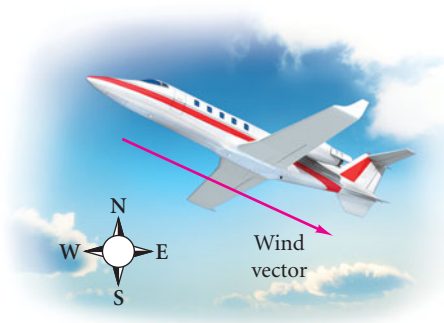

Vector

A **vector** in the plane is a directed line segment. Two vectors are **equivalent** if they have the same *magnitude* and the same *direction*.

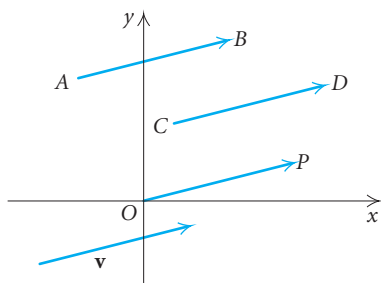

Consider a vector drawn from point A to point B . Point A is called the **initial point** of the vector, and point B is called the **terminal point**. Symbolic notation for this vector is \overrightarrow{AB} (read “vector AB ”). Vectors are also denoted by boldface letters such as \mathbf{u} , \mathbf{v} , and \mathbf{w} . The four vectors in the figure at left have the *same* length and the *same* direction. Thus they represent **equivalent** vectors; that is,

$$\overrightarrow{AB} = \overrightarrow{CD} = \overrightarrow{OP} = \mathbf{v}.$$

In the context of vectors, we use $=$ to mean equivalent.

The length, or **magnitude**, of \overrightarrow{AB} is expressed as $|\overrightarrow{AB}|$. In order to determine whether vectors are equivalent, we find their magnitudes and directions.

EXAMPLE 1 The vectors \mathbf{u} , \overrightarrow{OR} , and \mathbf{w} are shown in the figure below. Show that $\mathbf{u} = \overrightarrow{OR} = \mathbf{w}$.

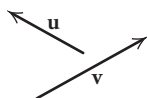
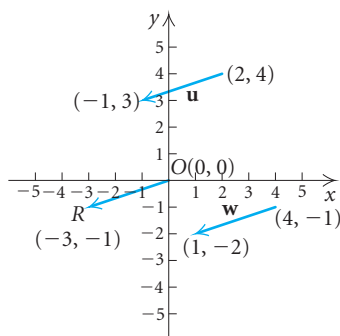

$\mathbf{u} \neq \mathbf{v}$ (not equivalent)
Different magnitudes;
different directions

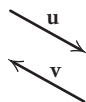

$\mathbf{u} \neq \mathbf{v}$
Same magnitude;
different directions

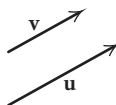

$\mathbf{u} \neq \mathbf{v}$
Different magnitudes;
same direction

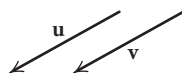

$\mathbf{u} = \mathbf{v}$
Same magnitude;
same direction

Solution We first find the length of each vector using the distance formula:

$$|\mathbf{u}| = \sqrt{[2 - (-1)]^2 + [4 - 3]^2} = \sqrt{9 + 1} = \sqrt{10},$$

$$|\overrightarrow{OR}| = \sqrt{[0 - (-3)]^2 + [0 - (-1)]^2} = \sqrt{9 + 1} = \sqrt{10},$$

$$|\mathbf{w}| = \sqrt{[4 - 1]^2 + [-1 - (-2)]^2} = \sqrt{9 + 1} = \sqrt{10}.$$

Thus,

$$|\mathbf{u}| = |\overrightarrow{OR}| = |\mathbf{w}|.$$

The vectors \mathbf{u} , \overrightarrow{OR} , and \mathbf{w} appear to go in the same direction so we check their slopes. If the lines that they are on all have the same slope, the vectors have the same direction. We calculate the slopes:

$$\text{Slope} = \frac{\mathbf{u}}{2 - (-1)} = \frac{\overrightarrow{OR}}{0 - (-3)} = \frac{\mathbf{w}}{-1 - (-2)} = \frac{4 - 3}{2 - (-1)} = \frac{0 - (-1)}{0 - (-3)} = \frac{-1 - (-2)}{4 - 1} = \frac{1}{3}.$$

Since \mathbf{u} , \overrightarrow{OR} , and \mathbf{w} have the *same* magnitude and the *same* direction,

$$\mathbf{u} = \overrightarrow{OR} = \mathbf{w}.$$

Now Try Exercise 1.

Keep in mind that the equivalence of vectors requires only the same magnitude and the same direction—not the same location. In the illustrations at left, each of the first three pairs of vectors are not equivalent. The fourth set of vectors is an example of equivalence.

► Vector Addition

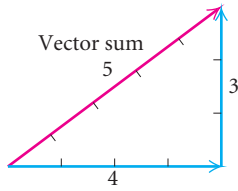

Suppose a person takes 4 steps east and then 3 steps north. He or she will then be 5 steps from the starting point in the direction shown at left. A vector 4 units long and pointing to the right represents 4 steps east and a vector 3 units long and pointing up represents 3 steps north. The **sum** of the two vectors is the vector 5 steps in magnitude and in the direction shown. The sum is also called the **resultant** of the two vectors.

In general, two nonzero vectors \mathbf{u} and \mathbf{v} can be added geometrically by placing the initial point of \mathbf{v} at the terminal point of \mathbf{u} and then finding the vector that has the same initial point as \mathbf{u} and the same terminal point as \mathbf{v} , as shown in the following figure.

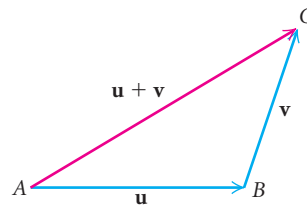

The sum $\mathbf{u} + \mathbf{v}$ is the vector represented by the directed line segment from the initial point A of \mathbf{u} to the terminal point C of \mathbf{v} . That is, if

$$\mathbf{u} = \overrightarrow{AB} \quad \text{and} \quad \mathbf{v} = \overrightarrow{BC},$$

then

$$\mathbf{u} + \mathbf{v} = \overrightarrow{AB} + \overrightarrow{BC} = \overrightarrow{AC}.$$

We can also describe vector addition by placing the initial points of the vectors together, completing a parallelogram, and finding the diagonal of the parallelogram. (See the figure on the left below.) This description of addition is sometimes called the **parallelogram law** of vector addition. Vector addition is **commutative**. As shown in the figure on the right below, both $\mathbf{u} + \mathbf{v}$ and $\mathbf{v} + \mathbf{u}$ are represented by the same directed line segment.

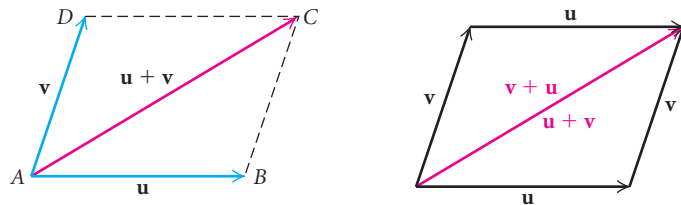

► Applications

If two forces F_1 and F_2 act on an object, the *combined* effect is the sum, or resultant, $F_1 + F_2$ of the separate forces.

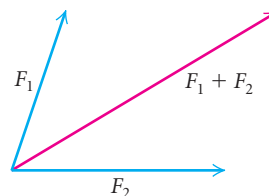

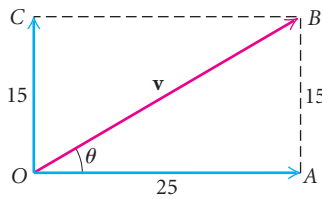

EXAMPLE 2 Forces of 15 newtons and 25 newtons act on an object at right angles to each other. Find their sum, or resultant, giving the magnitude of the resultant and the angle that it makes with the larger force.

Solution We make a drawing—this time, a rectangle—using \mathbf{v} or \overrightarrow{OB} to represent the resultant. To find the magnitude, we use the Pythagorean equation:

$$\begin{aligned} |\mathbf{v}|^2 &= 15^2 + 25^2 && \text{Here } |\mathbf{v}| \text{ denotes the length, or magnitude, of } \mathbf{v}. \\ |\mathbf{v}| &= \sqrt{15^2 + 25^2} \\ |\mathbf{v}| &\approx 29.2. \end{aligned}$$

To find the direction, we note that since OAB is a right triangle,

$$\tan \theta = \frac{15}{25} = 0.6.$$

Using a calculator, we find θ , the angle that the resultant makes with the larger force:

$$\theta = \tan^{-1}(0.6) \approx 31^\circ.$$

The resultant \overrightarrow{OB} has a magnitude of 29.2 and makes an angle of 31° with the larger force.

Now Try Exercise 13.

AERIAL BEARINGS

REVIEW SECTION 6.3

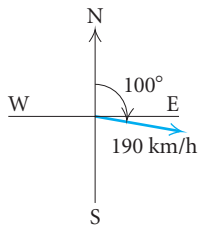

Airplane airspeed

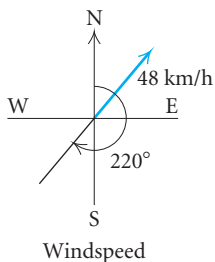

Windspeed

EXAMPLE 3 *Airplane Speed and Direction.* An airplane travels on a bearing of 100° at an airspeed of 190 km/h while a wind is blowing 48 km/h from 220° . Find the ground speed of the airplane and the direction of its track, or course, over the ground.

Solution We first make a drawing. The wind is represented by \overrightarrow{OC} and the velocity vector of the airplane by \overrightarrow{OA} . The resultant velocity vector is \mathbf{v} , the sum of the two vectors. The angle θ between \mathbf{v} and \overrightarrow{OA} is called a **drift angle**.

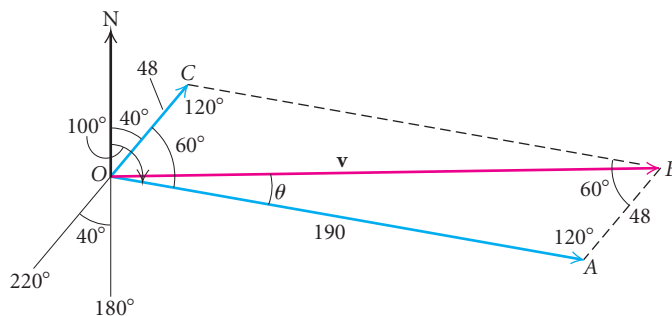

Note that the measure of $\angle COA = 100^\circ - 40^\circ = 60^\circ$. Thus the measure of $\angle CBA$ is also 60° (opposite angles of a parallelogram are equal). Since the sum of all the angles of the parallelogram is 360° and $\angle OCB$ and $\angle OAB$ have the same measure, each must be 120° . By the *law of cosines* in $\triangle OAB$, we have

$$\begin{aligned} |\mathbf{v}|^2 &= 48^2 + 190^2 - 2 \cdot 48 \cdot 190 \cos 120^\circ \\ |\mathbf{v}|^2 &= 47,524 \\ |\mathbf{v}| &= 218. \end{aligned}$$

Thus, $|\mathbf{v}|$ is 218 km/h. By the *law of sines* in the same triangle,

$$\frac{48}{\sin \theta} = \frac{218}{\sin 120^\circ},$$

or

$$\sin \theta = \frac{48 \sin 120^\circ}{218} \approx 0.1907$$

$$\theta \approx 11^\circ.$$

Thus, $\theta = 11^\circ$, to the nearest degree. The ground speed of the airplane is 218 km/h, and its track is in the direction of $100^\circ - 11^\circ$, or 89° .

 **Now Try Exercise 27.**

► Components

Given a vector \mathbf{w} , we may want to find two other vectors \mathbf{u} and \mathbf{v} whose sum is \mathbf{w} . The vectors \mathbf{u} and \mathbf{v} are called **components** of \mathbf{w} and the process of finding them is called **resolving**, or **representing**, a vector into its vector components.

When we resolve a vector, we generally look for perpendicular components. Most often, one component will be parallel to the x -axis and the other will be parallel to the y -axis. For this reason, they are often called the **horizontal** and **vertical** components of a vector. In the figure at left, the vector $\mathbf{w} = \overline{AC}$ is resolved as the sum of $\mathbf{u} = \overline{AB}$ and $\mathbf{v} = \overline{BC}$. The horizontal component of \mathbf{w} is \mathbf{u} and the vertical component is \mathbf{v} .

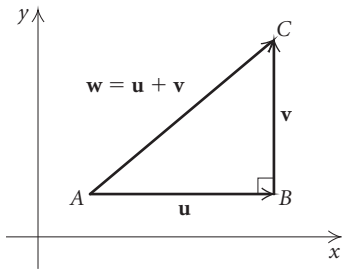

EXAMPLE 4 A vector \mathbf{w} has a magnitude of 130 and is inclined 40° with the horizontal. Resolve the vector into horizontal and vertical components.

Solution We first make a drawing showing horizontal and vertical vectors \mathbf{u} and \mathbf{v} whose sum is \mathbf{w} .

From $\triangle ABC$, we find $|\mathbf{u}|$ and $|\mathbf{v}|$ using the definitions of the cosine function and the sine function:

$$\cos 40^\circ = \frac{|\mathbf{u}|}{130}, \quad \text{or} \quad |\mathbf{u}| = 130 \cos 40^\circ \approx 100,$$

$$\sin 40^\circ = \frac{|\mathbf{v}|}{130}, \quad \text{or} \quad |\mathbf{v}| = 130 \sin 40^\circ \approx 84.$$

Thus the horizontal component of \mathbf{w} is 100 right, and the vertical component of \mathbf{w} is 84 up.

 **Now Try Exercise 31.**

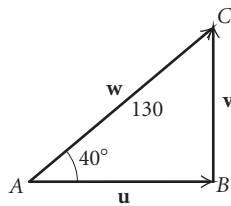

EXAMPLE 5 Shipping Crate. A wooden shipping crate that weighs 816 lb is placed on a loading ramp that makes an angle of 25° with the horizontal. To keep the crate from sliding, a chain is hooked to the crate and to a pole at the top of the ramp. Find the magnitude of the components of the crate's weight (disregarding friction) perpendicular and parallel to the incline.

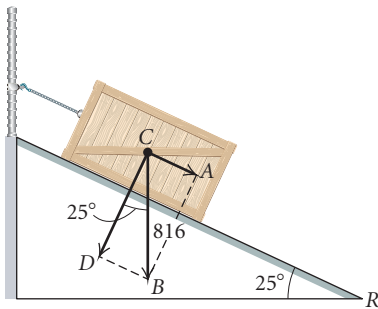

Solution We first make a drawing illustrating the forces with a rectangle. We let

$$|\overrightarrow{CB}| = \text{the weight of the crate} = 816 \text{ lb (force of gravity),}$$

$$|\overrightarrow{CD}| = \text{the magnitude of the component of the crate's weight perpendicular to the incline (force against the ramp), and}$$

$$|\overrightarrow{CA}| = \text{the magnitude of the component of the crate's weight parallel to the incline (force that pulls the crate down the ramp).}$$

The angle at R is given to be 25° and $\angle BCD = \angle R = 25^\circ$ because the sides of these angles are, respectively, perpendicular. Using the cosine function and the sine function, we find that

$$\cos 25^\circ = \frac{|\overrightarrow{CD}|}{816}, \quad \text{or} \quad |\overrightarrow{CD}| = 816 \cos 25^\circ \approx 740 \text{ lb, and}$$

$$\sin 25^\circ = \frac{|\overrightarrow{DB}|}{816} = \frac{|\overrightarrow{CA}|}{816}, \quad \text{or} \quad |\overrightarrow{CA}| = 816 \sin 25^\circ \approx 345 \text{ lb.}$$

Now Try Exercise 35.

8.5

Exercise Set

Sketch the pair of vectors and determine whether they are equivalent. Use the following ordered pairs for the initial and terminal points.

$$A(-2, 2) \quad E(-4, 1) \quad I(-6, -3)$$

$$B(3, 4) \quad F(2, 1) \quad J(3, 1)$$

$$C(-2, 5) \quad G(-4, 4) \quad K(-3, -3)$$

$$D(-1, -1) \quad H(1, 2) \quad O(0, 0)$$

1. $\overrightarrow{GE}, \overrightarrow{BJ}$

2. $\overrightarrow{DJ}, \overrightarrow{OF}$

3. $\overrightarrow{DJ}, \overrightarrow{AB}$

4. $\overrightarrow{CG}, \overrightarrow{FO}$

5. $\overrightarrow{DK}, \overrightarrow{BH}$

6. $\overrightarrow{BA}, \overrightarrow{DI}$

7. $\overrightarrow{EG}, \overrightarrow{BJ}$

8. $\overrightarrow{GC}, \overrightarrow{FO}$

9. $\overrightarrow{GA}, \overrightarrow{BH}$

10. $\overrightarrow{JD}, \overrightarrow{CG}$

11. $\overrightarrow{AB}, \overrightarrow{ID}$

12. $\overrightarrow{OF}, \overrightarrow{HB}$

13. Two forces of 32 N (newtons) and 45 N act on an object at right angles. Find the magnitude of the resultant and the angle that it makes with the smaller force.

14. Two forces of 50 N and 60 N act on an object at right angles. Find the magnitude of the resultant and the angle that it makes with the larger force.

15. Two forces of 410 N and 600 N act on an object. The angle between the forces is 47° . Find the magnitude of the resultant and the angle that it makes with the larger force.

16. Two forces of 255 N and 325 N act on an object. The angle between the forces is 64° . Find the magnitude of the resultant and the angle that it makes with the smaller force.

In Exercises 17–24, magnitudes of vectors \mathbf{u} and \mathbf{v} and the angle θ between the vectors are given. Find the sum of $\mathbf{u} + \mathbf{v}$. Give the magnitude to the nearest tenth and give the direction by specifying to the nearest degree the angle that the resultant makes with \mathbf{u} .

17. $|\mathbf{u}| = 45, |\mathbf{v}| = 35, \theta = 90^\circ$

18. $|\mathbf{u}| = 54, |\mathbf{v}| = 43, \theta = 150^\circ$

19. $|\mathbf{u}| = 10, |\mathbf{v}| = 12, \theta = 67^\circ$

20. $|\mathbf{u}| = 25, |\mathbf{v}| = 30, \theta = 75^\circ$

21. $|\mathbf{u}| = 20, |\mathbf{v}| = 20, \theta = 117^\circ$

22. $|\mathbf{u}| = 30, |\mathbf{v}| = 30, \theta = 123^\circ$

23. $|\mathbf{u}| = 23, |\mathbf{v}| = 47, \theta = 27^\circ$

24. $|\mathbf{u}| = 32, |\mathbf{v}| = 74, \theta = 72^\circ$

25. **Hot-Air Balloon.** A hot-air balloon is rising vertically 10 ft/sec while the wind is blowing horizontally 5 ft/sec. Find the speed \mathbf{v} of the balloon and the angle θ that it makes with the horizontal.

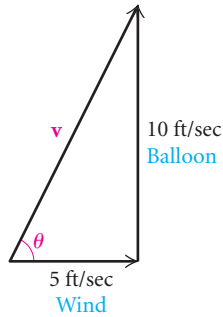

26. **Ship.** A ship sails first $N80^\circ E$ for 120 nautical mi, and then $S20^\circ W$ for 200 nautical mi. How far is the ship, then, from the starting point, and in what direction?
27. **Boat.** A boat heads 35° , propelled by a force of 750 lb. A wind from 320° exerts a force of 150 lb on the boat. How large is the resultant force \mathbf{F} , and in what direction is the boat moving?

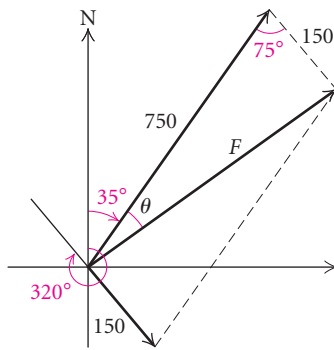

28. **Airplane.** An airplane flies 32° for 210 km, and then 280° for 170 km. How far is the airplane, then, from the starting point, and in what direction?
29. **Airplane.** An airplane has an airspeed of 150 km/h. It is to make a flight in a direction of 70° while there is a 25-km/h wind from 340° . What will the airplane's actual heading be?
30. **Wind.** A wind has an easterly component (from the east) of 10 km/h and a southerly component (from the south) of 16 km/h. Find the magnitude and the direction of the wind.
31. A vector \mathbf{w} has magnitude 100 and points southeast. Resolve the vector into easterly and southerly components.
32. A vector \mathbf{u} with a magnitude of 150 lb is inclined to the right and upward 52° from the horizontal. Resolve the vector into components.

33. **Airplane.** An airplane takes off at a speed S of 225 mph at an angle of 17° with the horizontal. Resolve the vector \mathbf{S} into components.
34. **Wheelbarrow.** A wheelbarrow is pushed by applying a 97-lb force \mathbf{F} that makes a 38° angle with the horizontal. Resolve \mathbf{F} into its horizontal and vertical components. (The horizontal component is the effective force in the direction of motion and the vertical component adds weight to the wheelbarrow.)

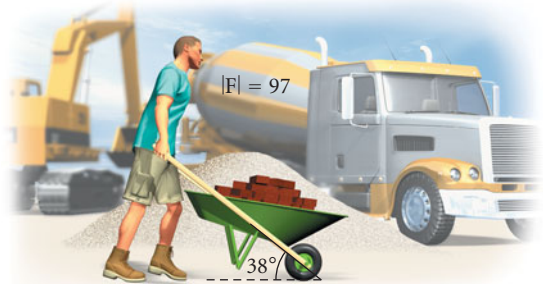

35. **Luggage Wagon.** A luggage wagon is being pulled with vector force \mathbf{V} , which has a magnitude of 780 lb at an angle of elevation of 60° . Resolve the vector \mathbf{V} into components.

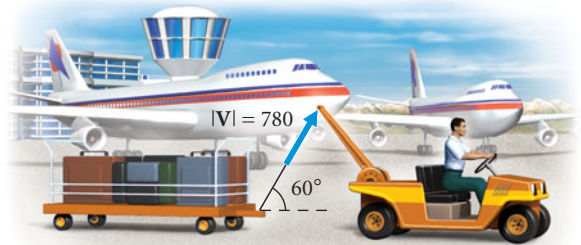

36. **Hot-Air Balloon.** A hot-air balloon exerts a 1200-lb pull on a tether line at a 45° angle with the horizontal. Resolve the vector \mathbf{B} into components.

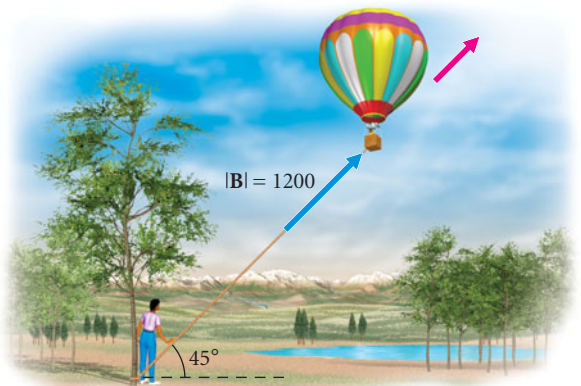

37. **Airplane.** An airplane is flying at 200 km/h in a direction of 305° . Find the westerly and northerly components of its velocity.
38. **Baseball.** A baseball player throws a baseball with a speed S of 72 mph at an angle of 45° with the horizontal. Resolve the vector S into components.
39. A block weighing 100 lb rests on a 25° incline. Find the magnitude of the components of the block's weight perpendicular and parallel to the incline.

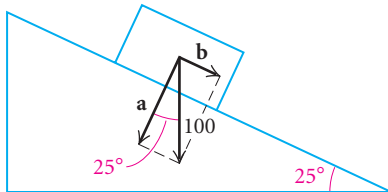

40. A shipping crate that weighs 450 kg is placed on a loading ramp that makes an angle of 30° with the horizontal. Find the magnitude of the components of the crate's weight perpendicular and parallel to the incline.
41. An 80-lb block of ice rests on a 37° incline. What force parallel to the incline is necessary in order to keep the ice from sliding down?
42. What force is necessary to pull a 3500-lb truck up a 9° incline?

Skill Maintenance

In each of Exercises 43–52, fill in the blank with the correct term. Some of the given choices will not be used.

angular speed	cosine
linear speed	common
acute	natural
obtuse	horizontal line
secant of θ	vertical line
cotangent of θ	double-angle
identity	half-angle
inverse	coterminal
absolute value	reference angle
sines	

43. Logarithms, base e , are called _____ logarithms.
44. _____ identities give trigonometric function values of $x/2$ in terms of function values of x .
45. _____ is distance traveled per unit of time.
46. The sine of an angle is also the _____ of the angle's complement.
47. A(n) _____ is an equation that is true for all possible replacements of the variables.
48. The _____ is the length of the side adjacent to θ divided by the length of the side opposite θ .
49. If two or more angles have the same terminal side, the angles are said to be _____.
50. In any triangle, the sides are proportional to the _____ of the opposite angles.
51. If it is possible for a(n) _____ to intersect the graph of a function more than once, then the function is not one-to-one and its _____ is not a function.
52. The _____ for an angle is the _____ angle formed by the terminal side of the angle and the x -axis.

Synthesis

53. **Eagle's Flight.** An eagle flies from its nest 7 mi in the direction northeast, where it stops to rest on a cliff. It then flies 8 mi in the direction $S30^\circ W$ to land on top of a tree. Place an xy -coordinate system so that the origin is the bird's nest, the x -axis points east, and the y -axis points north.
- At what point is the cliff located?
 - At what point is the tree located?

Vector Operations

8.6

- ▶ Perform calculations with vectors in component form.
- ▶ Express a vector as a linear combination of unit vectors.
- ▶ Express a vector in terms of its magnitude and its direction.
- ▶ Find the angle between two vectors using the dot product.
- ▶ Solve applied problems involving forces in equilibrium.

▶ Position Vectors

Let's consider a vector \mathbf{v} whose initial point is the *origin* in an xy -coordinate system and whose terminal point is (a, b) . We say that the vector is in **standard position** and refer to it as a position vector. Note that the ordered pair (a, b) defines the vector uniquely. Thus we can use (a, b) to denote the vector. To emphasize that we are thinking of a vector and to avoid the confusion of notation with ordered-pair and interval notation, we generally write

$$\mathbf{v} = \langle a, b \rangle.$$

The coordinate a is the *scalar horizontal component* of the vector, and the coordinate b is the *scalar vertical component* of the vector. By **scalar**, we mean a *numerical* quantity rather than a *vector* quantity. Thus, $\langle a, b \rangle$ is considered to be the *component form* of \mathbf{v} . Note that a and b are *not* vectors and should not be confused with the vector component definition given in Section 8.5.

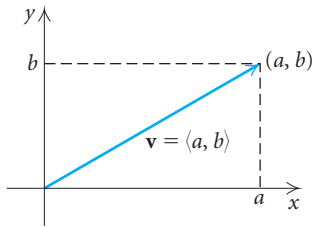

Now consider \overrightarrow{AC} with $A = (x_1, y_1)$ and $C = (x_2, y_2)$. Let's see how to find the position vector equivalent to \overrightarrow{AC} . As you can see in the figure below, the initial point A is relocated to the origin $(0, 0)$. The coordinates of P are found by subtracting the coordinates of A from the coordinates of C . Thus, $P = (x_2 - x_1, y_2 - y_1)$ and the position vector is \overrightarrow{OP} .

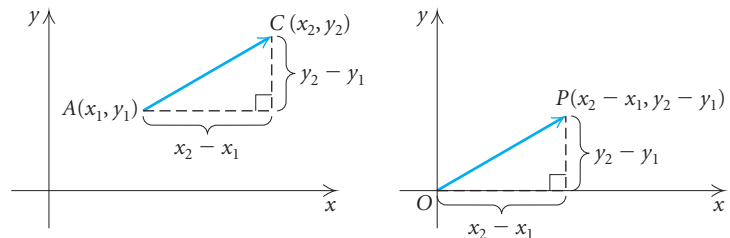

It can be shown that \overrightarrow{OP} and \overrightarrow{AC} have the same magnitude and direction and are therefore equivalent. Thus, $\overrightarrow{AC} = \overrightarrow{OP} = \langle x_2 - x_1, y_2 - y_1 \rangle$.

Component Form of a Vector

The **component form** of \overrightarrow{AC} with $A = (x_1, y_1)$ and $C = (x_2, y_2)$ is

$$\overrightarrow{AC} = \langle x_2 - x_1, y_2 - y_1 \rangle.$$

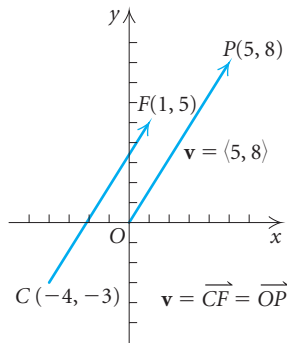

EXAMPLE 1 Find the component form of \overrightarrow{CF} if $C = (-4, -3)$ and $F = (1, 5)$.

Solution We have

$$\overrightarrow{CF} = \langle 1 - (-4), 5 - (-3) \rangle = \langle 5, 8 \rangle.$$

Note that vector \overrightarrow{CF} is equivalent to *position vector* \overrightarrow{OP} with $P = (5, 8)$ as shown in the figure at left.

Now that we know how to write vectors in component form, let's restate some definitions that we first considered in Section 8.5.

The length of a vector \mathbf{v} is easy to determine when the components of the vector are known. For $\mathbf{v} = \langle v_1, v_2 \rangle$, we have

$$|\mathbf{v}|^2 = v_1^2 + v_2^2 \quad \text{Using the Pythagorean equation}$$

$$|\mathbf{v}| = \sqrt{v_1^2 + v_2^2}.$$

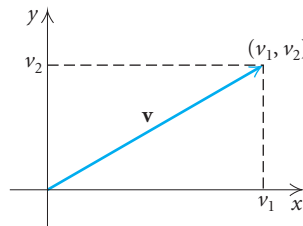

Length of a Vector

The **length**, or **magnitude**, of a vector $\mathbf{v} = \langle v_1, v_2 \rangle$ is given by

$$|\mathbf{v}| = \sqrt{v_1^2 + v_2^2}.$$

EXAMPLE 2 Find the length, or magnitude, of vector $\mathbf{v} = \langle 5, 8 \rangle$, illustrated in Example 1.

Solution

$$\begin{aligned} |\mathbf{v}| &= \sqrt{v_1^2 + v_2^2} \\ &= \sqrt{5^2 + 8^2} \\ &= \sqrt{25 + 64} \\ &= \sqrt{89} \end{aligned}$$

Length of vector $\mathbf{v} = \langle v_1, v_2 \rangle$

Substituting 5 for v_1 and 8 for v_2

Now Try Exercises 1 and 7.

Two vectors are **equivalent** if they have the *same* magnitude and the *same* direction.

Equivalent Vectors

Let $\mathbf{u} = \langle u_1, u_2 \rangle$ and $\mathbf{v} = \langle v_1, v_2 \rangle$. Then

$$\langle u_1, u_2 \rangle = \langle v_1, v_2 \rangle \text{ if and only if } u_1 = v_1 \text{ and } u_2 = v_2.$$

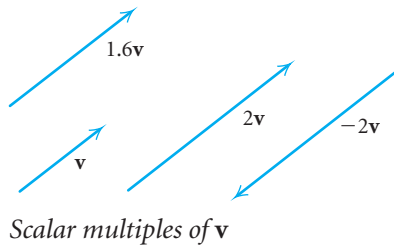

► Operations on Vectors

To multiply a vector \mathbf{v} by a positive real number, we multiply its length by the number. Its direction stays the same. When a vector \mathbf{v} is multiplied by 2, for instance, its length is doubled and its direction is not changed. When a vector is multiplied by 1.6, its length is increased by 60% and its direction stays the same. To multiply a vector \mathbf{v} by a negative real number, we multiply its length by the number and reverse its direction. When a vector is multiplied by -2 , its length is doubled and its direction is reversed. Since real numbers work like scaling factors in vector multiplication, we call them **scalars** and the products $k\mathbf{v}$ are called **scalar multiples** of \mathbf{v} .

Scalar Multiplication

For a real number k and a vector $\mathbf{v} = \langle v_1, v_2 \rangle$, the **scalar product** of k and \mathbf{v} is

$$k\mathbf{v} = k\langle v_1, v_2 \rangle = \langle kv_1, kv_2 \rangle.$$

The vector $k\mathbf{v}$ is a **scalar multiple** of the vector \mathbf{v} .

EXAMPLE 3 Let $\mathbf{u} = \langle -5, 4 \rangle$ and $\mathbf{w} = \langle 1, -1 \rangle$. Find $-7\mathbf{w}$, $3\mathbf{u}$, and $-1\mathbf{w}$.

Solution

$$-7\mathbf{w} = -7\langle 1, -1 \rangle = \langle -7, 7 \rangle,$$

$$3\mathbf{u} = 3\langle -5, 4 \rangle = \langle -15, 12 \rangle,$$

$$-1\mathbf{w} = -1\langle 1, -1 \rangle = \langle -1, 1 \rangle$$



In Section 8.5, we used the parallelogram law to add two vectors, but now we can add two vectors using components. To add two vectors given in component form, we add the corresponding components. Let $\mathbf{u} = \langle u_1, u_2 \rangle$ and $\mathbf{v} = \langle v_1, v_2 \rangle$. Then

$$\mathbf{u} + \mathbf{v} = \langle u_1 + v_1, u_2 + v_2 \rangle.$$

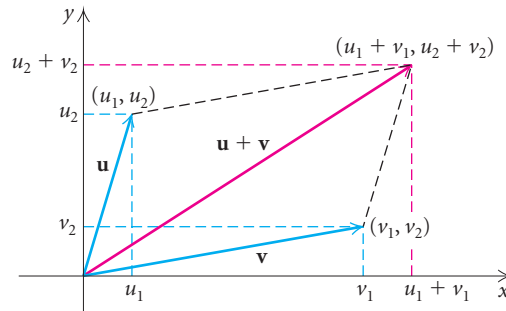

For example, if $\mathbf{v} = \langle -3, 2 \rangle$ and $\mathbf{w} = \langle 5, -9 \rangle$, then

$$\mathbf{v} + \mathbf{w} = \langle -3 + 5, 2 + (-9) \rangle = \langle 2, -7 \rangle.$$

Vector Addition

If $\mathbf{u} = \langle u_1, u_2 \rangle$ and $\mathbf{v} = \langle v_1, v_2 \rangle$, then

$$\mathbf{u} + \mathbf{v} = \langle u_1 + v_1, u_2 + v_2 \rangle.$$

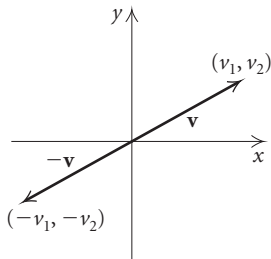

Before we define vector subtraction, we need to define $-\mathbf{v}$. The opposite of $\mathbf{v} = \langle v_1, v_2 \rangle$, shown at left, is

$$-\mathbf{v} = (-1)\mathbf{v} = (-1)\langle v_1, v_2 \rangle = \langle -v_1, -v_2 \rangle.$$

Vector subtraction such as $\mathbf{u} - \mathbf{v}$ involves subtracting corresponding components. We show this by rewriting $\mathbf{u} - \mathbf{v}$ as $\mathbf{u} + (-\mathbf{v})$. If $\mathbf{u} = \langle u_1, u_2 \rangle$ and $\mathbf{v} = \langle v_1, v_2 \rangle$, then

$$\begin{aligned} \mathbf{u} - \mathbf{v} &= \mathbf{u} + (-\mathbf{v}) = \langle u_1, u_2 \rangle + \langle -v_1, -v_2 \rangle \\ &= \langle u_1 + (-v_1), u_2 + (-v_2) \rangle \\ &= \langle u_1 - v_1, u_2 - v_2 \rangle. \end{aligned}$$

We can illustrate vector subtraction with parallelograms, just as we did vector addition.

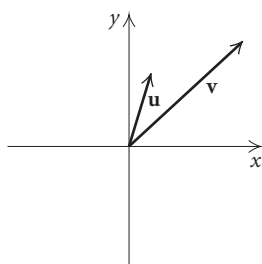
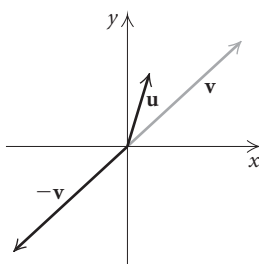
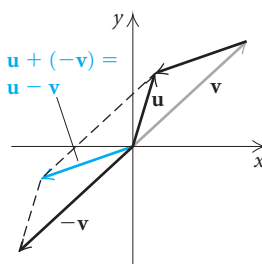
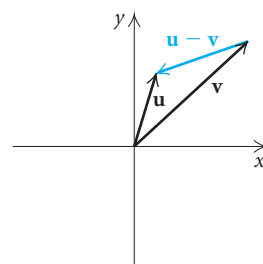
Sketch \mathbf{u} and \mathbf{v} .Sketch $-\mathbf{v}$.Sketch $\mathbf{u} + (-\mathbf{v})$, or $\mathbf{u} - \mathbf{v}$, using the parallelogram law. $\mathbf{u} - \mathbf{v}$ is the vector from the terminal point of \mathbf{v} to the terminal point of \mathbf{u} .

Vector Subtraction

If $\mathbf{u} = \langle u_1, u_2 \rangle$ and $\mathbf{v} = \langle v_1, v_2 \rangle$, then

$$\mathbf{u} - \mathbf{v} = \langle u_1 - v_1, u_2 - v_2 \rangle.$$

It is interesting to compare the sum of two vectors with the difference of the same two vectors in the same parallelogram. The vectors $\mathbf{u} + \mathbf{v}$ and $\mathbf{u} - \mathbf{v}$ are the diagonals of the parallelogram.

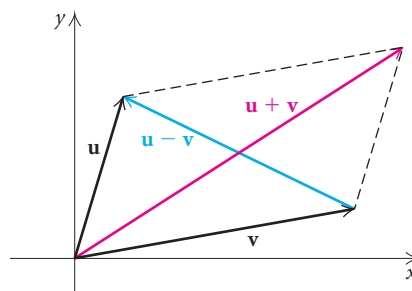

EXAMPLE 4 Do the following calculations, where $\mathbf{u} = \langle 7, 2 \rangle$ and $\mathbf{v} = \langle -3, 5 \rangle$.

- a) $\mathbf{u} + \mathbf{v}$
c) $3\mathbf{u} + 4\mathbf{v}$

- b) $\mathbf{u} - 6\mathbf{v}$
d) $|5\mathbf{v} - 2\mathbf{u}|$

Solution

- a) $\mathbf{u} + \mathbf{v} = \langle 7, 2 \rangle + \langle -3, 5 \rangle = \langle 7 + (-3), 2 + 5 \rangle = \langle 4, 7 \rangle$
 b) $\mathbf{u} - 6\mathbf{v} = \langle 7, 2 \rangle - 6\langle -3, 5 \rangle = \langle 7, 2 \rangle - \langle -18, 30 \rangle = \langle 25, -28 \rangle$
 c) $3\mathbf{u} + 4\mathbf{v} = 3\langle 7, 2 \rangle + 4\langle -3, 5 \rangle = \langle 21, 6 \rangle + \langle -12, 20 \rangle = \langle 9, 26 \rangle$
 d) $|5\mathbf{v} - 2\mathbf{u}| = |5\langle -3, 5 \rangle - 2\langle 7, 2 \rangle| = | \langle -15, 25 \rangle - \langle 14, 4 \rangle |$
 $= | \langle -29, 21 \rangle |$
 $= \sqrt{(-29)^2 + 21^2}$
 $= \sqrt{1282}$
 ≈ 35.8

 **Now Try Exercises 9 and 11.**

Before we state the properties of vector addition and scalar multiplication, we need to define another special vector—the zero vector. The vector whose initial and terminal points are both $(0, 0)$ is the **zero vector**, denoted by \mathbf{O} , or $\langle 0, 0 \rangle$. Its magnitude is 0. In vector addition, the zero vector is the additive identity vector:

$$\mathbf{v} + \mathbf{O} = \mathbf{v}. \quad \langle v_1, v_2 \rangle + \langle 0, 0 \rangle = \langle v_1, v_2 \rangle$$

Operations on vectors share many of the same properties as operations on real numbers.

Properties of Vector Addition and Scalar Multiplication

For all vectors \mathbf{u} , \mathbf{v} , and \mathbf{w} , and for all scalars b and c :

- $\mathbf{u} + \mathbf{v} = \mathbf{v} + \mathbf{u}$.
- $\mathbf{u} + (\mathbf{v} + \mathbf{w}) = (\mathbf{u} + \mathbf{v}) + \mathbf{w}$.
- $\mathbf{v} + \mathbf{O} = \mathbf{v}$.
- $1\mathbf{v} = \mathbf{v}$; $0\mathbf{v} = \mathbf{O}$.
- $\mathbf{v} + (-\mathbf{v}) = \mathbf{O}$.
- $b(c\mathbf{v}) = (bc)\mathbf{v}$.
- $(b + c)\mathbf{v} = b\mathbf{v} + c\mathbf{v}$.
- $b(\mathbf{u} + \mathbf{v}) = b\mathbf{u} + b\mathbf{v}$.

► Unit Vectors

A vector of magnitude, or length, 1 is called a **unit vector**. The vector $\mathbf{v} = \langle -\frac{3}{5}, \frac{4}{5} \rangle$ is a unit vector because

$$\begin{aligned} |\mathbf{v}| &= | \langle -\frac{3}{5}, \frac{4}{5} \rangle | = \sqrt{\left(-\frac{3}{5}\right)^2 + \left(\frac{4}{5}\right)^2} \\ &= \sqrt{\frac{9}{25} + \frac{16}{25}} \\ &= \sqrt{\frac{25}{25}} \\ &= \sqrt{1} = 1. \end{aligned}$$

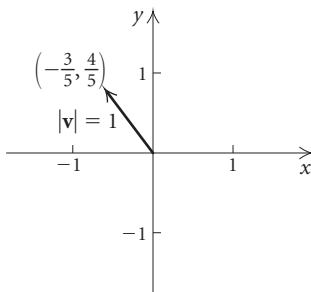

EXAMPLE 5 Find a unit vector that has the same direction as the vector $\mathbf{w} = \langle -3, 5 \rangle$.

Solution We first find the length of \mathbf{w} :

$$|\mathbf{w}| = \sqrt{(-3)^2 + 5^2} = \sqrt{34}.$$

Thus we want a vector whose length is $1/\sqrt{34}$ of \mathbf{w} and whose direction is the same as vector \mathbf{w} . That vector is

$$\mathbf{u} = \frac{1}{\sqrt{34}} \mathbf{w} = \frac{1}{\sqrt{34}} \langle -3, 5 \rangle = \left\langle \frac{-3}{\sqrt{34}}, \frac{5}{\sqrt{34}} \right\rangle.$$

The vector \mathbf{u} is a *unit vector* because

$$\begin{aligned} |\mathbf{u}| &= \left| \frac{1}{\sqrt{34}} \mathbf{w} \right| = \sqrt{\left(\frac{-3}{\sqrt{34}} \right)^2 + \left(\frac{5}{\sqrt{34}} \right)^2} = \sqrt{\frac{9}{34} + \frac{25}{34}} \\ &= \sqrt{\frac{34}{34}} = \sqrt{1} = 1. \end{aligned}$$

➔ Now Try Exercise 33.

Unit Vector

If \mathbf{v} is a vector and $\mathbf{v} \neq \mathbf{0}$, then

$$\frac{1}{|\mathbf{v}|} \cdot \mathbf{v}, \quad \text{or} \quad \frac{\mathbf{v}}{|\mathbf{v}|},$$

is a **unit vector** in the direction of \mathbf{v} .

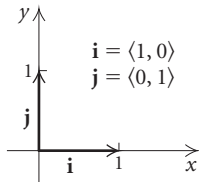

Although unit vectors can have any direction, the unit vectors parallel to the x - and y -axes are particularly useful. They are defined as

$$\mathbf{i} = \langle 1, 0 \rangle \quad \text{and} \quad \mathbf{j} = \langle 0, 1 \rangle.$$

Any vector can be expressed as a **linear combination** of unit vectors \mathbf{i} and \mathbf{j} . For example, let $\mathbf{v} = \langle v_1, v_2 \rangle$. Then

$$\begin{aligned} \mathbf{v} = \langle v_1, v_2 \rangle &= \langle v_1, 0 \rangle + \langle 0, v_2 \rangle \\ &= v_1 \langle 1, 0 \rangle + v_2 \langle 0, 1 \rangle = v_1 \mathbf{i} + v_2 \mathbf{j}. \end{aligned}$$

EXAMPLE 6 Express the vector $\mathbf{r} = \langle 2, -6 \rangle$ as a linear combination of \mathbf{i} and \mathbf{j} .

Solution We have

$$\mathbf{r} = \langle 2, -6 \rangle = 2\mathbf{i} + (-6)\mathbf{j} = 2\mathbf{i} - 6\mathbf{j}.$$

➔ Now Try Exercise 39.

EXAMPLE 7 Write the vector $\mathbf{q} = -\mathbf{i} + 7\mathbf{j}$ in component form.

Solution We have

$$\mathbf{q} = -\mathbf{i} + 7\mathbf{j} = -1\mathbf{i} + 7\mathbf{j} = \langle -1, 7 \rangle. \quad \leftarrow$$

Vector operations can also be performed when vectors are written as linear combinations of \mathbf{i} and \mathbf{j} .

EXAMPLE 8 If $\mathbf{a} = 5\mathbf{i} - 2\mathbf{j}$ and $\mathbf{b} = -\mathbf{i} + 8\mathbf{j}$, find $3\mathbf{a} - \mathbf{b}$.

Solution We have

$$\begin{aligned} 3\mathbf{a} - \mathbf{b} &= 3(5\mathbf{i} - 2\mathbf{j}) - (-\mathbf{i} + 8\mathbf{j}) \\ &= 15\mathbf{i} - 6\mathbf{j} + \mathbf{i} - 8\mathbf{j} \\ &= 16\mathbf{i} - 14\mathbf{j}. \end{aligned}$$

➔ Now Try Exercise 45.

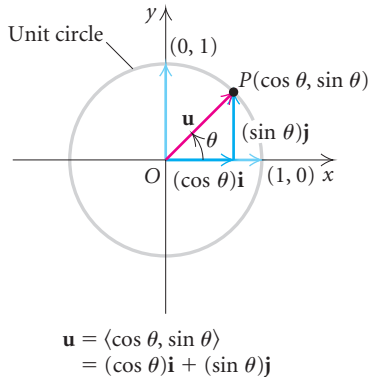

► Direction Angles

The terminal point P of a unit vector in standard position is a point on the unit circle denoted by $(\cos \theta, \sin \theta)$. Thus the unit vector can be expressed in component form,

$$\mathbf{u} = \langle \cos \theta, \sin \theta \rangle,$$

or as a linear combination of the unit vectors \mathbf{i} and \mathbf{j} ,

$$\mathbf{u} = (\cos \theta)\mathbf{i} + (\sin \theta)\mathbf{j},$$

where the components of \mathbf{u} are functions of the **direction angle** θ measured counterclockwise from the x -axis to the vector. As θ varies from 0 to 2π , the point P traces the circle $x^2 + y^2 = 1$. This takes in all possible directions for unit vectors so the equation $\mathbf{u} = (\cos \theta)\mathbf{i} + (\sin \theta)\mathbf{j}$ describes every possible unit vector in the plane.

EXAMPLE 9 Calculate and sketch the unit vector $\mathbf{u} = (\cos \theta)\mathbf{i} + (\sin \theta)\mathbf{j}$ for $\theta = 2\pi/3$. Include the unit circle in your sketch.

Solution We have

$$\begin{aligned} \mathbf{u} &= \left(\cos \frac{2\pi}{3} \right)\mathbf{i} + \left(\sin \frac{2\pi}{3} \right)\mathbf{j} \\ &= \left(-\frac{1}{2} \right)\mathbf{i} + \left(\frac{\sqrt{3}}{2} \right)\mathbf{j}. \end{aligned}$$

➔ Now Try Exercise 49.

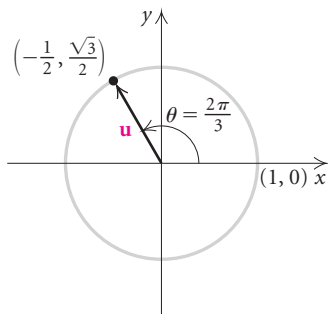

Let $\mathbf{v} = \langle v_1, v_2 \rangle$ with direction angle θ . Using the definition of the tangent function, we can determine the direction angle from the components of \mathbf{v} :

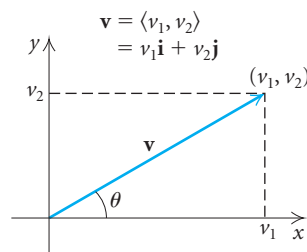

$$\begin{aligned} \tan \theta &= \frac{v_2}{v_1} \\ \theta &= \tan^{-1} \frac{v_2}{v_1}. \end{aligned}$$

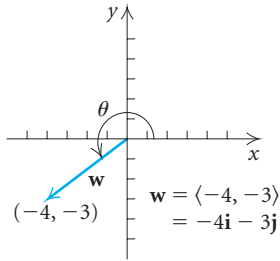

EXAMPLE 10 Determine the direction angle θ of the vector $\mathbf{w} = -4\mathbf{i} - 3\mathbf{j}$.

Solution We know that

$$\mathbf{w} = -4\mathbf{i} - 3\mathbf{j} = \langle -4, -3 \rangle.$$

Thus we have

$$\tan \theta = \frac{-3}{-4} = \frac{3}{4} \quad \text{and} \quad \theta = \tan^{-1} \frac{3}{4}.$$

Since \mathbf{w} is in the third quadrant, we know that θ is a third-quadrant angle. The reference angle is

$$\tan^{-1} \frac{3}{4} \approx 37^\circ, \quad \text{and} \quad \theta \approx 180^\circ + 37^\circ, \text{ or } 217^\circ.$$

Now Try Exercise 55.

It is convenient for work with applied problems and in subsequent courses, such as calculus, to have a way to express a vector so that both its magnitude and its direction can be determined, or read, easily. Let \mathbf{v} be a vector. Then $\mathbf{v}/|\mathbf{v}|$ is a unit vector in the same direction as \mathbf{v} . Thus we have

$$\frac{\mathbf{v}}{|\mathbf{v}|} = (\cos \theta)\mathbf{i} + (\sin \theta)\mathbf{j}$$

$$\mathbf{v} = |\mathbf{v}|[(\cos \theta)\mathbf{i} + (\sin \theta)\mathbf{j}] \quad \text{Multiplying by } |\mathbf{v}|$$

$$\mathbf{v} = |\mathbf{v}|(\cos \theta)\mathbf{i} + |\mathbf{v}|(\sin \theta)\mathbf{j}.$$

Let's revisit the applied problem in Example 3 of Section 8.5 and use this new notation.

EXAMPLE 11 Airplane Speed and Direction. An airplane travels on a bearing of 100° at an airspeed of 190 km/h while a wind is blowing 48 km/h from 220° . Find the ground speed of the airplane and the direction of its track, or course, over the ground.

Solution We first make a drawing. The wind is represented by \overrightarrow{OC} and the velocity vector of the airplane by \overrightarrow{OA} . The resultant velocity vector is \mathbf{v} , the sum of the two vectors:

$$\mathbf{v} = \overrightarrow{OC} + \overrightarrow{OA}.$$

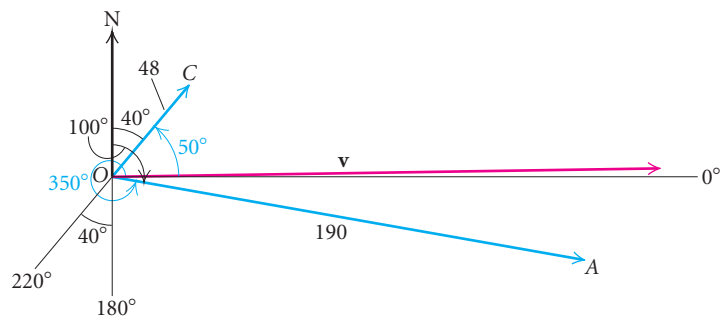

The bearing (measured from north) of the airspeed vector \overrightarrow{OA} is 100° . Its *direction angle* (measured counterclockwise from the positive x -axis) is 350° . The bearing (measured from north) of the wind vector \overrightarrow{OC} is 40° . Its direction angle (measured counterclockwise from the positive x -axis) is 50° . The magnitudes of \overrightarrow{OA} and \overrightarrow{OC} are 190 and 48, respectively. We have

$$\begin{aligned}\overrightarrow{OA} &= 190(\cos 350^\circ)\mathbf{i} + 190(\sin 350^\circ)\mathbf{j}, \quad \text{and} \\ \overrightarrow{OC} &= 48(\cos 50^\circ)\mathbf{i} + 48(\sin 50^\circ)\mathbf{j}.\end{aligned}$$

Thus,

$$\begin{aligned}\mathbf{v} &= \overrightarrow{OA} + \overrightarrow{OC} \\ &= [190(\cos 350^\circ)\mathbf{i} + 190(\sin 350^\circ)\mathbf{j}] + [48(\cos 50^\circ)\mathbf{i} + 48(\sin 50^\circ)\mathbf{j}] \\ &= [190(\cos 350^\circ) + 48(\cos 50^\circ)]\mathbf{i} + [190(\sin 350^\circ) + 48(\sin 50^\circ)]\mathbf{j} \\ &\approx 217.97\mathbf{i} + 3.78\mathbf{j}.\end{aligned}$$

From this form, we can determine the ground speed and the course:

$$\begin{aligned}\text{Ground speed} &\approx \sqrt{(217.97)^2 + (3.78)^2} \\ &\approx 218 \text{ km/h}.\end{aligned}$$

We let α be the direction angle of \mathbf{v} . Then

$$\begin{aligned}\tan \alpha &= \frac{3.78}{217.97} \\ \alpha &= \tan^{-1} \frac{3.78}{217.97} \approx 1^\circ.\end{aligned}$$

Thus the course of the airplane (the direction from north) is $90^\circ - 1^\circ$, or 89° . 

► Angle Between Vectors

When a vector is multiplied by a scalar, the result is a vector. When two vectors are added, the result is also a vector. Thus we might expect the product of two vectors to be a vector as well, but it is not. The *dot product* of two vectors is a real number, or scalar. This product is useful in finding the angle between two vectors and in determining whether two vectors are perpendicular.

Dot Product

The **dot product** of two vectors $\mathbf{u} = \langle u_1, u_2 \rangle$ and $\mathbf{v} = \langle v_1, v_2 \rangle$ is

$$\mathbf{u} \cdot \mathbf{v} = u_1v_1 + u_2v_2.$$

(Note that $u_1v_1 + u_2v_2$ is a *scalar*, not a vector.)

EXAMPLE 12 Find the indicated dot product when

$$\mathbf{u} = \langle 2, -5 \rangle, \quad \mathbf{v} = \langle 0, 4 \rangle, \quad \text{and} \quad \mathbf{w} = \langle -3, 1 \rangle.$$

a) $\mathbf{u} \cdot \mathbf{w}$

b) $\mathbf{w} \cdot \mathbf{v}$

Solution

$$\text{a) } \mathbf{u} \cdot \mathbf{w} = 2(-3) + (-5)1 = -6 - 5 = -11$$

$$\text{b) } \mathbf{w} \cdot \mathbf{v} = -3(0) + 1(4) = 0 + 4 = 4$$



The dot product can be used to find the angle between two vectors. The angle *between* two vectors is the smallest positive angle formed by the two directed line segments. Thus the angle θ between \mathbf{u} and \mathbf{v} is the same angle as that between \mathbf{v} and \mathbf{u} , and $0 \leq \theta \leq \pi$.

Angle Between Two Vectors

If θ is the angle between two *nonzero* vectors \mathbf{u} and \mathbf{v} , then

$$\cos \theta = \frac{\mathbf{u} \cdot \mathbf{v}}{|\mathbf{u}||\mathbf{v}|}.$$

EXAMPLE 13 Find the angle between $\mathbf{u} = \langle 3, 7 \rangle$ and $\mathbf{v} = \langle -4, 2 \rangle$.

Solution We begin by finding $\mathbf{u} \cdot \mathbf{v}$, $|\mathbf{u}|$, and $|\mathbf{v}|$:

$$\mathbf{u} \cdot \mathbf{v} = 3(-4) + 7(2) = 2,$$

$$|\mathbf{u}| = \sqrt{3^2 + 7^2} = \sqrt{58}, \quad \text{and}$$

$$|\mathbf{v}| = \sqrt{(-4)^2 + 2^2} = \sqrt{20}.$$

Then

$$\cos \alpha = \frac{\mathbf{u} \cdot \mathbf{v}}{|\mathbf{u}||\mathbf{v}|} = \frac{2}{\sqrt{58}\sqrt{20}}$$

$$\alpha = \cos^{-1} \frac{2}{\sqrt{58}\sqrt{20}}$$

$$\alpha \approx 86.6^\circ.$$

Now Try Exercise 63.

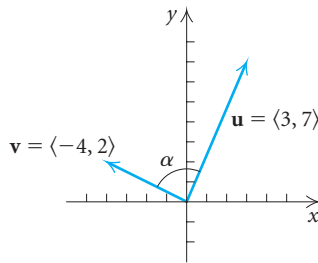
**► Forces in Equilibrium**

When several forces act through the same point on an object, their vector sum must be \mathbf{O} in order for a balance to occur. When a balance occurs, then the object is either stationary or moving in a straight line without acceleration. The fact that the vector sum must be \mathbf{O} for a balance, and vice versa, allows us to solve many applied problems involving forces.

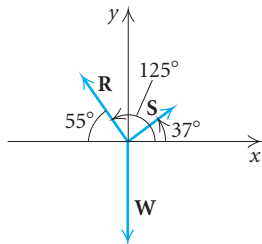
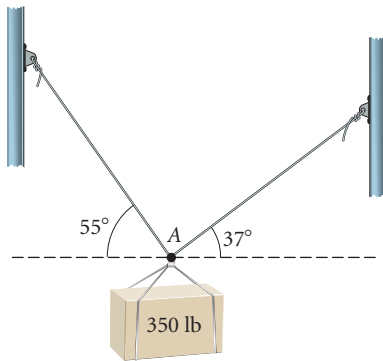

EXAMPLE 14 *Suspended Block.* A 350-lb block is suspended by two cables, as shown at left. At point A, there are three forces acting: \mathbf{W} , the block pulling down, and \mathbf{R} and \mathbf{S} , the two cables pulling upward and outward. Find the tension in each cable.

Solution We draw a force diagram with the initial points of each vector at the origin. For there to be a balance, the vector sum must be the vector \mathbf{O} :

$$\mathbf{R} + \mathbf{S} + \mathbf{W} = \mathbf{O}.$$

We can express each vector in terms of its magnitude and its direction angle:

$$\mathbf{R} = |\mathbf{R}|[(\cos 125^\circ)\mathbf{i} + (\sin 125^\circ)\mathbf{j}],$$

$$\mathbf{S} = |\mathbf{S}|[(\cos 37^\circ)\mathbf{i} + (\sin 37^\circ)\mathbf{j}], \text{ and}$$

$$\mathbf{W} = |\mathbf{W}|[(\cos 270^\circ)\mathbf{i} + (\sin 270^\circ)\mathbf{j}]$$

$$= 350(\cos 270^\circ)\mathbf{i} + 350(\sin 270^\circ)\mathbf{j}$$

$$= -350\mathbf{j}. \quad \cos 270^\circ = 0; \sin 270^\circ = -1$$

Substituting for \mathbf{R} , \mathbf{S} , and \mathbf{W} in $\mathbf{R} + \mathbf{S} + \mathbf{W} = \mathbf{O}$, we have

$$[|\mathbf{R}|(\cos 125^\circ) + |\mathbf{S}|(\cos 37^\circ)]\mathbf{i} + [|\mathbf{R}|(\sin 125^\circ) + |\mathbf{S}|(\sin 37^\circ) - 350]\mathbf{j} = 0\mathbf{i} + 0\mathbf{j}.$$

This gives us two equations:

$$|\mathbf{R}|(\cos 125^\circ) + |\mathbf{S}|(\cos 37^\circ) = 0 \quad \text{and} \quad (1)$$

$$|\mathbf{R}|(\sin 125^\circ) + |\mathbf{S}|(\sin 37^\circ) - 350 = 0. \quad (2)$$

Solving equation (1) for $|\mathbf{R}|$, we get

$$|\mathbf{R}| = -\frac{|\mathbf{S}|(\cos 37^\circ)}{\cos 125^\circ}. \quad (3)$$

Substituting this expression for $|\mathbf{R}|$ in equation (2) gives us

$$-\frac{|\mathbf{S}|(\cos 37^\circ)}{\cos 125^\circ}(\sin 125^\circ) + |\mathbf{S}|(\sin 37^\circ) - 350 = 0.$$

Then solving this equation for $|\mathbf{S}|$, we get $|\mathbf{S}| \approx 201$, and substituting 201 for $|\mathbf{S}|$ in equation (3), we get $|\mathbf{R}| \approx 280$. The tensions in the cables are 280 lb and 201 lb.

Now Try Exercise 83.

8.6

Exercise Set

Find the component form of the vector given the initial point and the terminal point. Then find the length of the vector.

- \overrightarrow{MN} ; $M(6, -7)$, $N(-3, -2)$
- \overrightarrow{CD} ; $C(1, 5)$, $D(5, 7)$
- \overrightarrow{FE} ; $E(8, 4)$, $F(11, -2)$

4. \overrightarrow{BA} ; $A(9, 0)$, $B(9, 7)$

5. \overrightarrow{KL} ; $K(4, -3)$, $L(8, -3)$

6. \overrightarrow{GH} ; $G(-6, 10)$, $H(-3, 2)$

7. Find the magnitude of vector \mathbf{u} if $\mathbf{u} = \langle -1, 6 \rangle$.

8. Find the magnitude of vector \overrightarrow{ST} if $\overrightarrow{ST} = \langle -12, 5 \rangle$.

Do the indicated calculations in Exercises 9–26 for the vectors

$$\mathbf{u} = \langle 5, -2 \rangle, \quad \mathbf{v} = \langle -4, 7 \rangle, \quad \text{and} \quad \mathbf{w} = \langle -1, -3 \rangle.$$

- | | |
|---|---|
| 9. $\mathbf{u} + \mathbf{w}$ | 10. $\mathbf{w} + \mathbf{u}$ |
| 11. $ 3\mathbf{w} - \mathbf{v} $ | 12. $6\mathbf{v} + 5\mathbf{u}$ |
| 13. $\mathbf{v} - \mathbf{u}$ | 14. $ 2\mathbf{w} $ |
| 15. $5\mathbf{u} - 4\mathbf{v}$ | 16. $-5\mathbf{v}$ |
| 17. $ 3\mathbf{u} - \mathbf{v} $ | 18. $ \mathbf{v} + \mathbf{u} $ |
| 19. $\mathbf{v} + \mathbf{u} + 2\mathbf{w}$ | 20. $\mathbf{w} - (\mathbf{u} + 4\mathbf{v})$ |
| 21. $2\mathbf{v} + \mathbf{O}$ | 22. $10 7\mathbf{w} - 3\mathbf{u} $ |
| 23. $\mathbf{u} \cdot \mathbf{w}$ | 24. $\mathbf{w} \cdot \mathbf{u}$ |
| 25. $\mathbf{u} \cdot \mathbf{v}$ | 26. $\mathbf{v} \cdot \mathbf{w}$ |

The vectors \mathbf{u} , \mathbf{v} , and \mathbf{w} are drawn below. Copy them on a sheet of paper. Then sketch each of the vectors in Exercises 27–30.

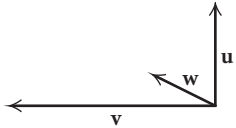

27. $\mathbf{u} + \mathbf{v}$ 28. $\mathbf{u} - 2\mathbf{v}$
29. $\mathbf{u} + \mathbf{v} + \mathbf{w}$ 30. $\frac{1}{2}\mathbf{u} - \mathbf{w}$
31. Vectors \mathbf{u} , \mathbf{v} , and \mathbf{w} are determined by the sides of $\triangle ABC$ below.

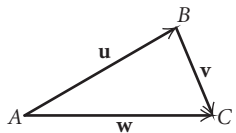

- a) Find an expression for \mathbf{w} in terms of \mathbf{u} and \mathbf{v} .
 b) Find an expression for \mathbf{v} in terms of \mathbf{u} and \mathbf{w} .
32. In $\triangle ABC$, vectors \mathbf{u} and \mathbf{w} are determined by the sides shown, where P is the midpoint of side BC . Find an expression for \mathbf{v} in terms of \mathbf{u} and \mathbf{w} .

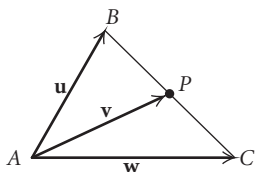

Find a unit vector that has the same direction as the given vector.

- | | |
|---|---|
| 33. $\mathbf{v} = \langle -5, 12 \rangle$ | 34. $\mathbf{u} = \langle 3, 4 \rangle$ |
| 35. $\mathbf{w} = \langle 1, -10 \rangle$ | 36. $\mathbf{a} = \langle 6, -7 \rangle$ |
| 37. $\mathbf{r} = \langle -2, -8 \rangle$ | 38. $\mathbf{t} = \langle -3, -3 \rangle$ |

Express the vector as a linear combination of the unit vectors \mathbf{i} and \mathbf{j} .

- | | |
|--|---|
| 39. $\mathbf{w} = \langle -4, 6 \rangle$ | 40. $\mathbf{r} = \langle -15, 9 \rangle$ |
| 41. $\mathbf{s} = \langle 2, 5 \rangle$ | 42. $\mathbf{u} = \langle 2, -1 \rangle$ |

Express the vector as a linear combination of \mathbf{i} and \mathbf{j} .

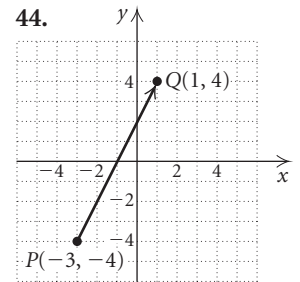
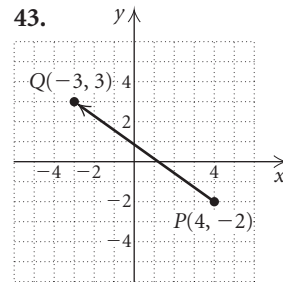

For Exercises 45–48, use the vectors

$$\mathbf{u} = 2\mathbf{i} + \mathbf{j}, \quad \mathbf{v} = -3\mathbf{i} - 10\mathbf{j}, \quad \text{and} \quad \mathbf{w} = \mathbf{i} - 5\mathbf{j}.$$

Perform the indicated vector operations and state the answer in two forms: (a) as a linear combination of \mathbf{i} and \mathbf{j} and (b) in component form.

- | | |
|--|--|
| 45. $4\mathbf{u} - 5\mathbf{w}$ | 46. $\mathbf{v} + 3\mathbf{w}$ |
| 47. $\mathbf{u} - (\mathbf{v} + \mathbf{w})$ | 48. $(\mathbf{u} - \mathbf{v}) + \mathbf{w}$ |

Sketch (include the unit circle) and calculate the unit vector $\mathbf{u} = (\cos \theta)\mathbf{i} + (\sin \theta)\mathbf{j}$ for the given direction angle.

- | | |
|-------------------------------|-------------------------------|
| 49. $\theta = \frac{\pi}{2}$ | 50. $\theta = \frac{\pi}{3}$ |
| 51. $\theta = \frac{4\pi}{3}$ | 52. $\theta = \frac{3\pi}{2}$ |

Determine the direction angle θ of the vector, to the nearest degree.

- | | |
|---|---|
| 53. $\mathbf{u} = \langle -2, -5 \rangle$ | 54. $\mathbf{w} = \langle 4, -3 \rangle$ |
| 55. $\mathbf{q} = \mathbf{i} + 2\mathbf{j}$ | 56. $\mathbf{w} = 5\mathbf{i} - \mathbf{j}$ |
| 57. $\mathbf{t} = \langle 5, 6 \rangle$ | 58. $\mathbf{b} = \langle -8, -4 \rangle$ |

Find the magnitude and the direction angle θ of the vector.

59. $\mathbf{u} = 3[(\cos 45^\circ)\mathbf{i} + (\sin 45^\circ)\mathbf{j}]$

60. $\mathbf{w} = 6[(\cos 150^\circ)\mathbf{i} + (\sin 150^\circ)\mathbf{j}]$

61. $\mathbf{v} = \left\langle -\frac{1}{2}, \frac{\sqrt{3}}{2} \right\rangle$

62. $\mathbf{u} = -\mathbf{i} - \mathbf{j}$

Find the angle between the given vectors, to the nearest tenth of a degree.

63. $\mathbf{u} = \langle 2, -5 \rangle$, $\mathbf{v} = \langle 1, 4 \rangle$

64. $\mathbf{a} = \langle -3, -3 \rangle$, $\mathbf{b} = \langle -5, 2 \rangle$

65. $\mathbf{w} = \langle 3, 5 \rangle$, $\mathbf{r} = \langle 5, 5 \rangle$

66. $\mathbf{v} = \langle -4, 2 \rangle$, $\mathbf{t} = \langle 1, -4 \rangle$

67. $\mathbf{a} = \mathbf{i} + \mathbf{j}$, $\mathbf{b} = 2\mathbf{i} - 3\mathbf{j}$

68. $\mathbf{u} = 3\mathbf{i} + 2\mathbf{j}$, $\mathbf{v} = -\mathbf{i} + 4\mathbf{j}$

Express each vector in Exercises 69–72 in the form $a\mathbf{i} + b\mathbf{j}$ and sketch each in the coordinate plane.

69. The unit vectors $\mathbf{u} = (\cos \theta)\mathbf{i} + (\sin \theta)\mathbf{j}$ for $\theta = \pi/6$ and $\theta = 3\pi/4$. Include the unit circle $x^2 + y^2 = 1$ in your sketch.

70. The unit vectors $\mathbf{u} = (\cos \theta)\mathbf{i} + (\sin \theta)\mathbf{j}$ for $\theta = -\pi/4$ and $\theta = -3\pi/4$. Include the unit circle $x^2 + y^2 = 1$ in your sketch.

71. The unit vector obtained by rotating \mathbf{j} counterclockwise $3\pi/4$ radians about the origin

72. The unit vector obtained by rotating \mathbf{j} clockwise $2\pi/3$ radians about the origin

For the vectors in Exercises 73 and 74, find the unit vectors $\mathbf{u} = (\cos \theta)\mathbf{i} + (\sin \theta)\mathbf{j}$ in the same direction.

73. $-\mathbf{i} + 3\mathbf{j}$

74. $6\mathbf{i} - 8\mathbf{j}$

For the vectors in Exercises 75 and 76, express each vector in terms of its magnitude and its direction.

75. $2\mathbf{i} - 3\mathbf{j}$

76. $5\mathbf{i} + 12\mathbf{j}$

77. Use a sketch to show that

$$\mathbf{v} = 3\mathbf{i} - 6\mathbf{j} \quad \text{and} \quad \mathbf{u} = -\mathbf{i} + 2\mathbf{j}$$

have opposite directions.

78. Use a sketch to show that

$$\mathbf{v} = 3\mathbf{i} - 6\mathbf{j} \quad \text{and} \quad \mathbf{u} = \frac{1}{2}\mathbf{i} - \mathbf{j}$$

have the same direction.

Exercises 79–82 appeared first in Exercise Set 8.5, where we used the law of cosines and the law of sines to solve the applied problems. For this exercise set, solve the problem using the vector form

$$\mathbf{v} = |\mathbf{v}|[(\cos \theta)\mathbf{i} + (\sin \theta)\mathbf{j}].$$

79. **Ship.** A ship sails first N80°E for 120 nautical mi, and then S20°W for 200 nautical mi. How far is the ship, then, from the starting point, and in what direction is the ship moving?

80. **Boat.** A boat heads 35°, propelled by a force of 750 lb. A wind from 320° exerts a force of 150 lb on the boat. How large is the resultant force, and in what direction is the boat moving?

81. **Airplane.** An airplane has an airspeed of 150 km/h. It is to make a flight in a direction of 070° while there is a 25-km/h wind from 340°. What will the airplane's actual heading be?

82. **Airplane.** An airplane flies 032° for 210 mi, and then 280° for 170 mi. How far is the airplane, then, from the starting point, and in what direction is the plane moving?

83. Two cables support a 1000-lb weight, as shown. Find the tension in each cable.

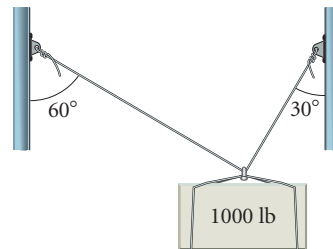

84. A 2500-kg block is suspended by two ropes, as shown. Find the tension in each rope.

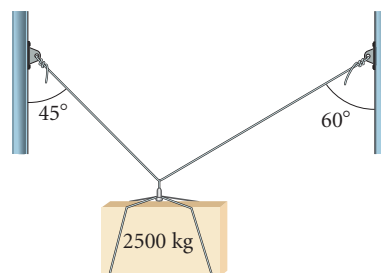

85. A 150-lb sign is hanging from the end of a hinged boom, supported by a cable inclined 42° with the horizontal. Find the tension in the cable and the compression in the boom.

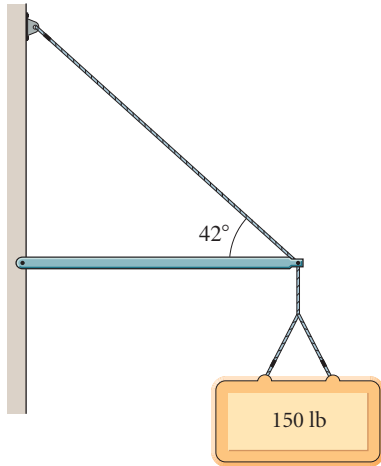

86. A weight of 200 lb is supported by a frame made of two rods and hinged at points A , B , and C . Find the forces exerted by the two rods.

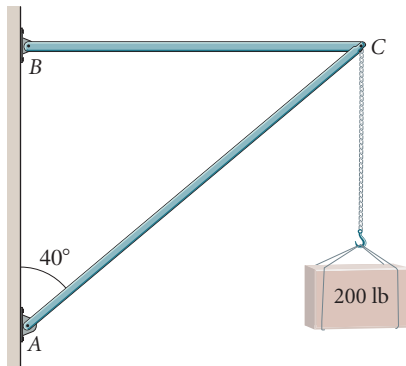

Let $\mathbf{u} = \langle u_1, u_2 \rangle$ and $\mathbf{v} = \langle v_1, v_2 \rangle$. Prove each of the following properties.

87. $\mathbf{u} + \mathbf{v} = \mathbf{v} + \mathbf{u}$

88. $\mathbf{u} \cdot \mathbf{v} = \mathbf{v} \cdot \mathbf{u}$

Skill Maintenance

Find the slope and the y -intercept of the line with the given equation.

89. $-\frac{1}{5}x - y = 15$

90. $y = 7$

Find the zeros of the function.

91. $x^3 - 4x^2 = 0$

92. $6x^2 + 7x = 55$

Synthesis

93. If the dot product of two nonzero vectors \mathbf{u} and \mathbf{v} is 0, then the vectors are perpendicular (**orthogonal**). Let $\mathbf{u} = \langle u_1, u_2 \rangle$ and $\mathbf{v} = \langle v_1, v_2 \rangle$.
- Prove that if $\mathbf{u} \cdot \mathbf{v} = 0$, then \mathbf{u} and \mathbf{v} are perpendicular.
 - Give an example of two perpendicular vectors and show that their dot product is 0.
94. If \overrightarrow{PQ} is any vector, what is $\overrightarrow{PQ} + \overrightarrow{QP}$?
95. Find all the unit vectors that are parallel to the vector $\langle 3, -4 \rangle$.
96. Find a vector of length 2 whose direction is the opposite of the direction of the vector $\mathbf{v} = -\mathbf{i} + 2\mathbf{j}$. How many such vectors are there?
97. Given the vector $\overrightarrow{AB} = 3\mathbf{i} - \mathbf{j}$ and A is the point $(2, 9)$, find the point B .
98. Find vector \mathbf{v} from point A to the origin, where $\overrightarrow{AB} = 4\mathbf{i} - 2\mathbf{j}$ and B is the point $(-2, 5)$.

Chapter 8 Summary and Review

STUDY GUIDE

KEY TERMS AND CONCEPTS

SECTION 8.1: THE LAW OF SINES

Solving a Triangle

To **solve a triangle** means to find the lengths of all its sides and the measures of all its angles.

Any triangle, right or oblique, can be solved *if at least one side and any other two measures are known*. We cannot solve a triangle when only the three angle measures are given.

The Law of Sines

In any $\triangle ABC$,

$$\frac{a}{\sin A} = \frac{b}{\sin B} = \frac{c}{\sin C}.$$

The law of sines is used to solve triangles given a side and two angles (AAS and ASA) or given two sides and an angle opposite one of them (SSA). In the SSA situation, there are three possibilities: *no solution*, *one solution*, or *two solutions*.

EXAMPLES

Solve $\triangle RST$, if $r = 47.6$, $S = 123.5^\circ$, and $T = 31.4^\circ$.

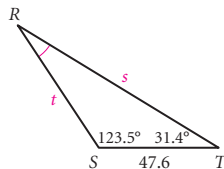

$$\begin{aligned} R &= ?, & r &= 47.6, \\ S &= 123.5^\circ, & s &= ?, \\ T &= 31.4^\circ, & t &= ? \end{aligned}$$

We have the ASA situation. We first find R :

$$R = 180^\circ - (123.5^\circ + 31.4^\circ) = 25.1^\circ.$$

We then find the other two sides using the law of sines. We have

$$\frac{47.6}{\sin 25.1^\circ} = \frac{s}{\sin 123.5^\circ}. \quad \text{Using } \frac{r}{\sin R} = \frac{s}{\sin S}$$

Solving for s , we get $s \approx 93.6$. We have

$$\frac{47.6}{\sin 25.1^\circ} = \frac{t}{\sin 31.4^\circ}. \quad \text{Using } \frac{r}{\sin R} = \frac{t}{\sin T}$$

Solving for t , we get $t \approx 58.5$.

We have solved the triangle:

$$\begin{aligned} R &= 25.1^\circ, & r &= 47.6, \\ S &= 123.5^\circ, & s &\approx 93.6, \\ T &= 31.4^\circ, & t &\approx 58.5. \end{aligned}$$

Solve $\triangle DEF$, if $d = 35.6$, $f = 48.1$, and $D = 32.2^\circ$.

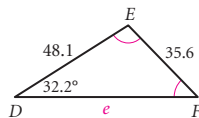

$$\begin{aligned} D &= 32.2^\circ, & d &= 35.6, \\ E &= ?, & e &= ?, \\ F &= ?, & f &= 48.1 \end{aligned}$$

We have the SSA situation. We first find F :

$$\begin{aligned} \frac{48.1}{\sin F} &= \frac{35.6}{\sin 32.2^\circ} & \text{Using } \frac{f}{\sin F} &= \frac{d}{\sin D} \\ \sin F &= \frac{48.1 \sin 32.2^\circ}{35.6} \approx 0.7200. \end{aligned}$$

There are two angles less than 180° with a sine of 0.7200. They are 46.1° and 133.9° . This gives us two possible solutions.

(Continued)

Possible solution I:

If $F \approx 46.1^\circ$, then $E = 180^\circ - (32.2^\circ + 46.1^\circ) = 101.7^\circ$. Then we find e using the law of sines:

$$\frac{e}{\sin 101.7^\circ} = \frac{35.6}{\sin 32.2^\circ} \quad \text{Using } \frac{e}{\sin E} = \frac{d}{\sin D}$$

Solving for e , we get $e \approx 65.4$. The solution is

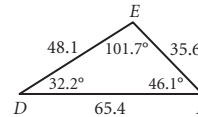

Possible solution II:

If $F \approx 133.9^\circ$, then $E = 180^\circ - (32.2^\circ + 133.9^\circ) = 13.9^\circ$. Then we find e using the law of sines:

$$\frac{e}{\sin 13.9^\circ} = \frac{35.6}{\sin 32.2^\circ} \quad \text{Using } \frac{e}{\sin E} = \frac{d}{\sin D}$$

Solving for e , we get $e \approx 16.0$. The solution is

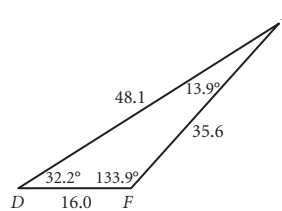

The Area of a Triangle

The area K of any $\triangle ABC$ is one-half of the product of the lengths of two sides and the sine of the included angle:

$$K = \frac{1}{2}bc \sin A = \frac{1}{2}ab \sin C = \frac{1}{2}ac \sin B.$$

Find the area of $\triangle ABC$ if $C = 115^\circ$, $a = 10$ m, and $b = 13$ m.

$$K = \frac{1}{2}ab \sin C$$

$$K = \frac{1}{2} \cdot 10 \text{ m} \cdot 13 \text{ m} \cdot \sin 115^\circ$$

$$K \approx 59 \text{ m}^2$$

SECTION 8.2: THE LAW OF COSINES

The Law of Cosines

In any $\triangle ABC$,

$$a^2 = b^2 + c^2 - 2bc \cos A,$$

$$b^2 = a^2 + c^2 - 2ac \cos B,$$

$$c^2 = a^2 + b^2 - 2ab \cos C.$$

The law of cosines is used to solve triangles given two sides and the included angle (SAS) or given three sides (SSS).

Solve $\triangle PQR$, if $p = 27$, $r = 39$, and $Q = 110.8^\circ$.

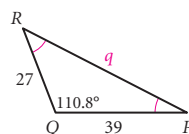

$$\begin{aligned} P &= ?, & p &= 27, \\ Q &= 110.8^\circ, & q &= ?, \\ R &= ?, & r &= 39 \end{aligned}$$

We can find the third side using the law of cosines:

$$q^2 = p^2 + r^2 - 2pr \cos Q$$

$$q^2 = 27^2 + 39^2 - 2 \cdot 27 \cdot 39 \cdot \cos 110.8^\circ$$

$$q^2 \approx 2997.9$$

$$q \approx 55.$$

(Continued)

We then find angle R using the law of cosines:

$$\begin{aligned} r^2 &= p^2 + q^2 - 2pq \cos R \\ 39^2 &= 27^2 + 55^2 - 2 \cdot 27 \cdot 55 \cdot \cos R \\ \cos R &= \frac{27^2 + 55^2 - 39^2}{2 \cdot 27 \cdot 55} \approx 0.7519. \end{aligned}$$

Since $\cos R$ is positive, R is acute:

$$R \approx 41.2^\circ.$$

Thus angle $P \approx 180^\circ - (41.2^\circ + 110.8^\circ) \approx 28.0^\circ$. We have solved the triangle:

$$\begin{aligned} P &\approx 28.0^\circ, & p &= 27, \\ Q &= 110.8^\circ, & q &\approx 55, \\ R &\approx 41.2^\circ, & r &= 39. \end{aligned}$$

SECTION 8.3: COMPLEX NUMBERS: TRIGONOMETRIC FORM

Complex numbers can be graphed on a plane. We graph $a + bi$ in the same way that we graph an ordered pair of numbers (a, b) .

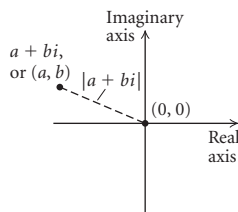

Absolute Value of a Complex Number

$$|a + bi| = \sqrt{a^2 + b^2}$$

Trigonometric Notation for Complex Numbers

$$a + bi = r(\cos \theta + i \sin \theta)$$

To find trigonometric notation for a complex number given in *standard notation*, $a + bi$, we find r and determine the angle θ for which $\sin \theta = b/r$ and $\cos \theta = a/r$.

Graph the complex numbers $2 - 4i$ and $\frac{7}{3}i$ and find the absolute value of each.

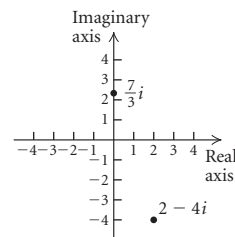

$$|2 - 4i| = \sqrt{2^2 + (-4)^2} = \sqrt{4 + 16} = \sqrt{20} = 2\sqrt{5};$$

$$\left| \frac{7}{3}i \right| = \sqrt{0^2 + \left(\frac{7}{3}\right)^2} = \sqrt{\left(\frac{7}{3}\right)^2} = \frac{7}{3}$$

Find trigonometric notation for $-1 + i$.

We have

$$a = -1 \text{ and } b = 1,$$

$$r = \sqrt{a^2 + b^2} = \sqrt{(-1)^2 + 1^2} = \sqrt{1 + 1} = \sqrt{2},$$

$$\sin \theta = \frac{b}{r} = \frac{1}{\sqrt{2}} = \frac{\sqrt{2}}{2} \quad \text{and} \quad \cos \theta = \frac{a}{r} = \frac{-1}{\sqrt{2}} = -\frac{\sqrt{2}}{2}.$$

Since θ is in quadrant II, $\theta = \frac{3\pi}{4}$, or 135° , and we have

$$-1 + i = \sqrt{2} \left(\cos \frac{3\pi}{4} + i \sin \frac{3\pi}{4} \right), \quad \text{or}$$

$$-1 + i = \sqrt{2}(\cos 135^\circ + i \sin 135^\circ).$$

Find standard notation, $a + bi$, for $2(\cos 210^\circ + i \sin 210^\circ)$.

We have

$$2(\cos 210^\circ + i \sin 210^\circ) = 2 \cos 210^\circ + (2 \sin 210^\circ)i.$$

Thus,

$$a = 2 \cos 210^\circ = 2 \cdot \left(-\frac{\sqrt{3}}{2}\right) = -\sqrt{3}, \quad \text{and}$$

$$b = 2 \sin 210^\circ = 2 \cdot \left(-\frac{1}{2}\right) = -1, \quad \text{so}$$

$$2(\cos 210^\circ + i \sin 210^\circ) = -\sqrt{3} - i.$$

Multiplication of Complex Numbers

$$\begin{aligned} r_1(\cos \theta_1 + i \sin \theta_1) \cdot r_2(\cos \theta_2 + i \sin \theta_2) \\ = r_1 r_2 [\cos(\theta_1 + \theta_2) + i \sin(\theta_1 + \theta_2)] \end{aligned}$$

Multiply $5(\cos \pi + i \sin \pi)$ and $2\left(\cos \frac{\pi}{6} + i \sin \frac{\pi}{6}\right)$ and express the answer in standard notation.

$$\begin{aligned} 5(\cos \pi + i \sin \pi) \cdot 2\left(\cos \frac{\pi}{6} + i \sin \frac{\pi}{6}\right) \\ = 5 \cdot 2 \left[\cos\left(\pi + \frac{\pi}{6}\right) + i \sin\left(\pi + \frac{\pi}{6}\right) \right] \\ = 10 \left(\cos \frac{7\pi}{6} + i \sin \frac{7\pi}{6} \right) \\ = 10 \left(-\frac{\sqrt{3}}{2} - \frac{1}{2}i \right) = -5\sqrt{3} - 5i \end{aligned}$$

Division of Complex Numbers

$$\begin{aligned} \frac{r_1(\cos \theta_1 + i \sin \theta_1)}{r_2(\cos \theta_2 + i \sin \theta_2)} \\ = \frac{r_1}{r_2} [\cos(\theta_1 - \theta_2) + i \sin(\theta_1 - \theta_2)], \quad r_2 \neq 0 \end{aligned}$$

Divide $3(\cos 315^\circ + i \sin 315^\circ)$ by $6(\cos 135^\circ + i \sin 135^\circ)$ and express the answer in standard notation.

$$\begin{aligned} \frac{3(\cos 315^\circ + i \sin 315^\circ)}{6(\cos 135^\circ + i \sin 135^\circ)} \\ = \frac{1}{2} [\cos(315^\circ - 135^\circ) + i \sin(315^\circ - 135^\circ)] \\ = \frac{1}{2} (\cos 180^\circ + i \sin 180^\circ) \\ = \frac{1}{2} (-1 + i \cdot 0) = -\frac{1}{2} \end{aligned}$$

DeMoivre's Theorem

$$[r(\cos \theta + i \sin \theta)]^n = r^n(\cos n\theta + i \sin n\theta)$$

Find $(-\sqrt{3} - i)^5$.

We first find trigonometric notation:

$$-\sqrt{3} - i = 2(\cos 210^\circ + i \sin 210^\circ).$$

Then

$$\begin{aligned} (-\sqrt{3} - i)^5 &= [2(\cos 210^\circ + i \sin 210^\circ)]^5 \\ &= 2^5(\cos 1050^\circ + i \sin 1050^\circ) \\ &= 32(\cos 330^\circ + i \sin 330^\circ) \\ &= 32 \left[\frac{\sqrt{3}}{2} - \frac{1}{2}i \right] \\ &= 16\sqrt{3} - 16i. \end{aligned}$$

Roots of Complex Numbers

The n th roots of $r(\cos \theta + i \sin \theta)$ are

$$r^{1/n} \left[\cos \left(\frac{\theta}{n} + k \cdot \frac{360^\circ}{n} \right) + i \sin \left(\frac{\theta}{n} + k \cdot \frac{360^\circ}{n} \right) \right],$$

$r \neq 0, k = 0, 1, 2, \dots, n - 1.$

Find the cube roots of -8 . Then locate them on a graph.

We first find trigonometric notation:

$$-8 = 8(\cos 180^\circ + i \sin 180^\circ).$$

Then $n = 3, 1/n = 1/3$, and $k = 0, 1, 2$; and

$$\begin{aligned} & [8(\cos 180^\circ + i \sin 180^\circ)]^{1/3} \\ &= 8^{1/3} \left[\cos \left(\frac{180^\circ}{3} + k \cdot \frac{360^\circ}{3} \right) + i \sin \left(\frac{180^\circ}{3} + k \cdot \frac{360^\circ}{3} \right) \right], \end{aligned}$$

$k = 0, 1, 2.$

The roots are

$$2(\cos 60^\circ + i \sin 60^\circ),$$

$$2(\cos 180^\circ + i \sin 180^\circ), \text{ and}$$

$$2(\cos 300^\circ + i \sin 300^\circ), \text{ or}$$

$$1 + \sqrt{3}i, \quad -2, \quad \text{and} \quad 1 - \sqrt{3}i.$$

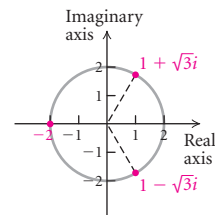
**SECTION 8.4: POLAR COORDINATES AND GRAPHS****Plotting Points on a Polar Graph**

Any point P has rectangular coordinates (x, y) and polar coordinates (r, θ) . To plot points on a polar graph:

1. Locate the direction angle θ .
2. Move a directed distance r from the pole. If $r > 0$, move along ray OP . If $r < 0$, move in the opposite direction of ray OP .

Graph each of the following points:

$$A(4, 240^\circ), \quad B\left(-2, \frac{2\pi}{3}\right), \quad C(3, -45^\circ), \quad D(0, \pi), \quad E\left(-5, \frac{3\pi}{2}\right).$$

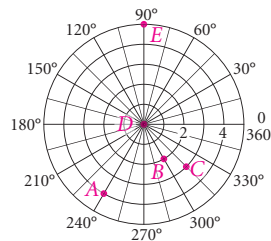

To convert from rectangular coordinates to polar coordinates and from polar coordinates to rectangular coordinates, recall the following relationships:

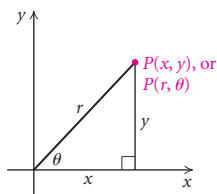

$$r = \sqrt{x^2 + y^2},$$

$$\cos \theta = \frac{x}{r}, \quad \text{or} \quad x = r \cos \theta,$$

$$\sin \theta = \frac{y}{r}, \quad \text{or} \quad y = r \sin \theta,$$

$$\tan \theta = \frac{y}{x}.$$

Convert $(-5, 5\sqrt{3})$ to polar coordinates.

We first find r :

$$r = \sqrt{(-5)^2 + (5\sqrt{3})^2} = \sqrt{25 + 75} = \sqrt{100} = 10.$$

Then we determine θ :

$$\tan \theta = \frac{5\sqrt{3}}{-5} = -\sqrt{3}; \quad \text{therefore, } \theta = 120^\circ, \quad \text{or} \quad \frac{2\pi}{3}.$$

Thus, $(r, \theta) = (10, 120^\circ)$, or $(10, 2\pi/3)$.

Other possibilities for polar coordinates for this point include $(10, -4\pi/3)$ and $(-10, 300^\circ)$.

Convert $(4, 210^\circ)$ to rectangular coordinates.

The ordered pair $(4, 210^\circ)$ gives us $r = 4$ and $\theta = 210^\circ$. We now find x and y :

$$x = r \cos \theta = 4 \cos 210^\circ = 4 \cdot \left(-\frac{\sqrt{3}}{2}\right) = -2\sqrt{3};$$

$$y = r \sin \theta = 4 \sin 210^\circ = 4\left(-\frac{1}{2}\right) = -2.$$

Thus, $(x, y) = (-2\sqrt{3}, -2)$.

Some curves have simpler equations in polar coordinates than in rectangular coordinates. For others, the reverse is true.

Convert each of the following rectangular equations to a polar equation.

a) $x^2 + y^2 = 100$ b) $y - 3x = 11$

a) $x^2 + y^2 = 100$

$$(r \cos \theta)^2 + (r \sin \theta)^2 = 100$$

$$r^2 \cos^2 \theta + r^2 \sin^2 \theta = 100$$

$$r^2(\cos^2 \theta + \sin^2 \theta) = 100$$

$$r^2 = 100$$

$$\cos^2 \theta + \sin^2 \theta = 1$$

$$r = 10$$

b) $y - 3x = 11$

$$(r \sin \theta) - 3(r \cos \theta) = 11$$

$$r(\sin \theta - 3 \cos \theta) = 11$$

Convert each of the following polar equations to a rectangular equation.

a) $r = 7$ b) $r = 3 \sin \theta - 5 \cos \theta$

a) $r = 7$

$$\sqrt{x^2 + y^2} = 7$$

$$x^2 + y^2 = 49$$

b) $r = 3 \sin \theta - 5 \cos \theta$

$$r^2 = 3r \sin \theta - 5r \cos \theta$$

Multiplying by r on both sides

$$x^2 + y^2 = 3y - 5x$$

To graph a polar equation:

1. Make a table of values, choosing values of θ and calculating corresponding values of r . As θ increases sufficiently, points may begin to repeat.
2. Plot the points and complete the graph.

Graph: $r = 2 - 3 \cos \theta$.

θ	r
0°	-1
15°	-0.8978
30°	-0.5981
45°	-0.1213
60°	0.5
75°	1.2235
90°	2
105°	2.7765
120°	3.5
135°	4.1213
150°	4.5981
165°	4.8978
180°	5

θ	r
195°	4.8978
210°	4.5981
225°	4.1213
240°	3.5
255°	2.7765
270°	2
285°	1.2235
300°	0.5
315°	-0.1213
330°	-0.5981
345°	-0.8978
360°	-1

(Continued)

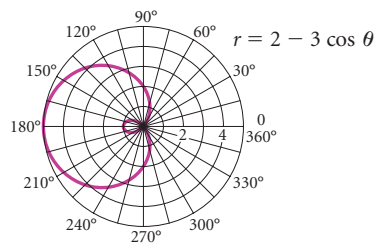

SECTION 8.5: VECTORS AND APPLICATIONS

Vector

A vector in the plane is a directed line segment. Two vectors are equivalent if they have the same *magnitude* and the same *direction*.

The vectors \mathbf{v} and \overrightarrow{AB} are shown in the figure below. Show that \mathbf{v} and \overrightarrow{AB} are equivalent.

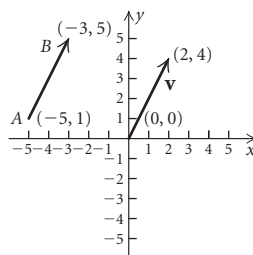

We first find the length:

$$\begin{aligned} |\mathbf{v}| &= \sqrt{(2 - 0)^2 + (4 - 0)^2} \\ &= \sqrt{2^2 + 4^2} \\ &= \sqrt{20}; \end{aligned}$$

$$\begin{aligned} |\overrightarrow{AB}| &= \sqrt{[-3 - (-5)]^2 + (5 - 1)^2} \\ &= \sqrt{2^2 + 4^2} \\ &= \sqrt{20}. \end{aligned}$$

Thus, $|\mathbf{v}| = |\overrightarrow{AB}|$.

The slopes of the lines that the vectors are on are

$$\begin{aligned} \text{Slope of } \mathbf{v} &= \frac{4 - 0}{2 - 0} \\ &= \frac{4}{2} = 2, \end{aligned}$$

$$\begin{aligned} \text{Slope of } \overrightarrow{AB} &= \frac{5 - 1}{-3 - (-5)} \\ &= \frac{4}{2} = 2. \end{aligned}$$

Since the slopes are the same, vectors \mathbf{v} and \overrightarrow{AB} have the same direction.

Since \mathbf{v} and \overrightarrow{AB} have the same magnitude and the same direction, $\mathbf{v} = \overrightarrow{AB}$.

If two forces F_1 and F_2 act on an object, the combined effect is the sum, or resultant, $F_1 + F_2$ of the separate forces.

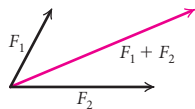

Two forces of 85 N and 120 N act on an object. The angle between the forces is 62° . Find the magnitude of the resultant and the angle that it makes with the larger force.

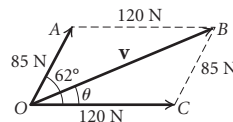

We have

$$\angle A = 180^\circ - 62^\circ = 118^\circ.$$

We use the law of cosines to find the magnitude of the resultant \mathbf{v} :

$$\begin{aligned} |\mathbf{v}|^2 &= 120^2 + 85^2 - 2 \cdot 120 \cdot 85 \cdot \cos 118^\circ \\ |\mathbf{v}| &\approx \sqrt{31,202} \\ &\approx 177 \text{ N.} \end{aligned}$$

We use the law of sines to find θ :

$$\begin{aligned} \frac{177}{\sin 118^\circ} &= \frac{85}{\sin \theta} \\ \sin \theta &= \frac{85 \sin 118^\circ}{177} \approx 0.4240 \\ \theta &\approx 25^\circ. \end{aligned}$$

The magnitude of \mathbf{v} is approximately 177 N, and it makes a 25° angle with the larger force, 120 N.

Horizontal and Vertical Components of a Vector

The components of vector \mathbf{w} are vectors \mathbf{u} and \mathbf{v} such that $\mathbf{w} = \mathbf{u} + \mathbf{v}$. We generally look for perpendicular components, with one component parallel to the x -axis (horizontal component) and the other parallel to the y -axis (vertical component).

A vector \mathbf{w} has a magnitude of 200 and is inclined 52° with the horizontal. Resolve the vector into horizontal and vertical components.

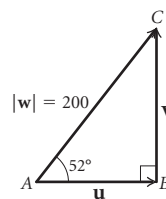

From $\triangle ABC$, we first find $|\mathbf{u}|$ and $|\mathbf{v}|$:

$$\begin{aligned} \cos 52^\circ &= \frac{|\mathbf{u}|}{200}, \quad \text{or} \quad |\mathbf{u}| = 200 \cos 52^\circ \approx 123; \\ \sin 52^\circ &= \frac{|\mathbf{v}|}{200}, \quad \text{or} \quad |\mathbf{v}| = 200 \sin 52^\circ \approx 158. \end{aligned}$$

Thus the horizontal component of \mathbf{w} is 123 right, and the vertical component of \mathbf{w} is 158 up.

Given $|\mathbf{u}| = 16$ and $|\mathbf{v}| = 19$, and that the angle between the vectors is 130° , find the sum of $\mathbf{u} + \mathbf{v}$. Give the magnitude to the nearest tenth and give the direction by specifying to the nearest degree the angle that the resultant makes with \mathbf{u} .

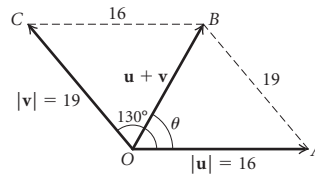

We first find A :

$$A = 180^\circ - 130^\circ = 50^\circ.$$

We use the law of cosines to find $|\mathbf{u} + \mathbf{v}|$:

$$\begin{aligned} |\mathbf{u} + \mathbf{v}|^2 &= 19^2 + 16^2 - 2 \cdot 19 \cdot 16 \cos 50^\circ \\ |\mathbf{u} + \mathbf{v}| &\approx \sqrt{226.19} \approx 15.0. \end{aligned}$$

Next, we use the law of cosines to find θ :

$$\begin{aligned} 19^2 &\approx 15^2 + 16^2 - 2 \cdot 15 \cdot 16 \cos \theta \\ \cos \theta &\approx 0.25 \\ \theta &\approx 76^\circ. \end{aligned}$$

The magnitude of $\mathbf{u} + \mathbf{v} \approx 15$, and the angle that $\mathbf{u} + \mathbf{v}$ makes with \mathbf{u} is about 76° .

SECTION 8.6: VECTOR OPERATIONS

Component Form of a Vector

$$\mathbf{v} = \langle a, b \rangle$$

The coordinate a is the scalar **horizontal component** of the vector, and the coordinate b is the scalar **vertical component**.

The **component form** of \overrightarrow{AC} with $A = (x_1, y_1)$ and $C = (x_2, y_2)$ is

$$\overrightarrow{AC} = \langle x_2 - x_1, y_2 - y_1 \rangle.$$

Vectors

If $\mathbf{u} = \langle u_1, u_2 \rangle$ and $\mathbf{v} = \langle v_1, v_2 \rangle$ and k is a scalar, then:

Length: $|\mathbf{v}| = \sqrt{v_1^2 + v_2^2};$

Addition: $\mathbf{u} + \mathbf{v} = \langle u_1 + v_1, u_2 + v_2 \rangle;$

Subtraction: $\mathbf{u} - \mathbf{v} = \langle u_1 - v_1, u_2 - v_2 \rangle;$

Scalar

Multiplication: $k\mathbf{v} = \langle kv_1, kv_2 \rangle;$

Dot Product: $\mathbf{u} \cdot \mathbf{v} = u_1v_1 + u_2v_2.$

Equivalent Vectors

Let $\mathbf{u} = \langle u_1, u_2 \rangle$ and $\mathbf{v} = \langle v_1, v_2 \rangle$. Then $\langle u_1, u_2 \rangle = \langle v_1, v_2 \rangle$ if and only if $u_1 = v_1$ and $u_2 = v_2$.

Find the component form of \overrightarrow{QR} given $Q(3, -9)$ and $R(-5, 4)$.

Then find the length, or magnitude, of \overrightarrow{QR} .

$$\begin{aligned} \overrightarrow{QR} &= \langle -5 - 3, 4 - (-9) \rangle = \langle -8, 13 \rangle \\ |\overrightarrow{QR}| &= \sqrt{(-8)^2 + 13^2} = \sqrt{64 + 169} = \sqrt{233} \approx 15.3 \end{aligned}$$

Do the indicated calculations, where $\mathbf{u} = \langle -6, 2 \rangle$ and $\mathbf{v} = \langle 8, 3 \rangle$.

a) $\mathbf{v} - 2\mathbf{u}$ b) $5\mathbf{u} + 3\mathbf{v}$
c) $|\mathbf{u} - \mathbf{v}|$ d) $\mathbf{u} \cdot \mathbf{v}$

a) $\mathbf{v} - 2\mathbf{u} = \langle 8, 3 \rangle - 2\langle -6, 2 \rangle$
 $= \langle 8, 3 \rangle - \langle -12, 4 \rangle$
 $= \langle 20, -1 \rangle$

b) $5\mathbf{u} + 3\mathbf{v} = 5\langle -6, 2 \rangle + 3\langle 8, 3 \rangle$
 $= \langle -30, 10 \rangle + \langle 24, 9 \rangle$
 $= \langle -6, 19 \rangle$

c) $|\mathbf{u} - \mathbf{v}| = |\langle -6, 2 \rangle - \langle 8, 3 \rangle|$
 $= | \langle -14, -1 \rangle |$
 $= \sqrt{(-14)^2 + (-1)^2}$
 $= \sqrt{197}$
 ≈ 14.0

d) $\mathbf{u} \cdot \mathbf{v} = -6 \cdot 8 + 2 \cdot 3$
 $= -42$

Zero Vector

The vector whose initial and terminal points are both $(0, 0)$ is the **zero vector**, denoted by \mathbf{O} , or $\langle 0, 0 \rangle$. Its magnitude is 0. In vector addition, the zero vector is the additive identity vector:

$$\mathbf{v} + \mathbf{O} = \mathbf{v}.$$

Unit Vector

A vector of magnitude, or length, 1 is called a **unit vector**.

If \mathbf{v} is a vector and $\mathbf{v} \neq \mathbf{O}$, then

$$\frac{1}{|\mathbf{v}|} \cdot \mathbf{v}, \text{ or } \frac{\mathbf{v}}{|\mathbf{v}|},$$

is a unit vector in the direction of \mathbf{v} .

Unit vectors parallel to the x - and y -axes are defined as

$$\mathbf{i} = \langle 1, 0 \rangle \text{ and } \mathbf{j} = \langle 0, 1 \rangle.$$

Any vector can be expressed as a linear combination of unit vectors \mathbf{i} and \mathbf{j} :

$$\mathbf{v} = \langle v_1, v_2 \rangle = v_1\mathbf{i} + v_2\mathbf{j}.$$

Direction Angles

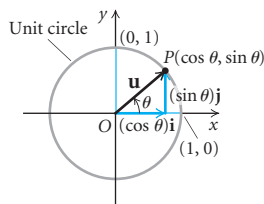

The unit vector can be expressed in component form,

$$\mathbf{u} = \langle \cos \theta, \sin \theta \rangle,$$

or

$$\mathbf{u} = (\cos \theta)\mathbf{i} + (\sin \theta)\mathbf{j},$$

where the components of \mathbf{u} are functions of the direction angle θ measured counterclockwise from the x -axis to the vector.

Find a unit vector that has the same direction as the vector $\mathbf{w} = \langle -9, 4 \rangle$.

We first find the length of \mathbf{w} :

$$|\mathbf{w}| = \sqrt{(-9)^2 + 4^2} = \sqrt{81 + 16} = \sqrt{97}.$$

We are looking for a vector whose length is $1/\sqrt{97}$ of \mathbf{w} and whose direction is the same as vector \mathbf{w} :

$$\mathbf{u} = \frac{1}{\sqrt{97}}\mathbf{w} = \frac{1}{\sqrt{97}}\langle -9, 4 \rangle = \left\langle -\frac{9}{\sqrt{97}}, \frac{4}{\sqrt{97}} \right\rangle.$$

Express the vector $\mathbf{q} = \langle 18, -7 \rangle$ as a linear combination of \mathbf{i} and \mathbf{j} .

$$\mathbf{q} = \langle 18, -7 \rangle = 18\mathbf{i} + (-7)\mathbf{j} = 18\mathbf{i} - 7\mathbf{j}$$

Write the vector $\mathbf{r} = -4\mathbf{i} + \mathbf{j}$ in component form.

$$\mathbf{r} = -4\mathbf{i} + \mathbf{j} = -4\mathbf{i} + 1\mathbf{j} = \langle -4, 1 \rangle$$

Calculate and sketch the unit vector

$$\mathbf{u} = (\cos \theta)\mathbf{i} + (\sin \theta)\mathbf{j} \text{ for } \theta = 5\pi/4.$$

$$\mathbf{u} = \left(\cos \frac{5\pi}{4} \right)\mathbf{i} + \left(\sin \frac{5\pi}{4} \right)\mathbf{j}$$

$$\mathbf{u} = \left(-\frac{\sqrt{2}}{2} \right)\mathbf{i} + \left(-\frac{\sqrt{2}}{2} \right)\mathbf{j}$$

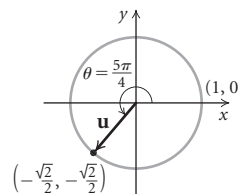

Determine the direction angle θ of the vector to the nearest degree.

a) $\mathbf{t} = \langle -2, 9 \rangle$ b) $\mathbf{b} = 5\mathbf{i} + 3\mathbf{j}$

a) $\mathbf{t} = \langle -2, 9 \rangle$

$$\tan \theta = \frac{9}{-2} = -\frac{9}{2} \text{ and } \theta = \tan^{-1} \left(-\frac{9}{2} \right) \approx -77^\circ$$

Since \mathbf{t} is in quadrant II, we know that θ is a second-quadrant angle. The reference angle is 77° . Thus,

$$\theta \approx 180^\circ - 77^\circ, \text{ or } 103^\circ.$$

(Continued)

Angle Between Two Vectors

$$\cos \theta = \frac{\mathbf{u} \cdot \mathbf{v}}{|\mathbf{u}| |\mathbf{v}|}$$

Forces in Equilibrium

When several forces act through the same point on an object, their vector sum must be \mathbf{O} in order for a balance to occur.

$$\mathbf{b} = 5\mathbf{i} + 3\mathbf{j} = \langle 5, 3 \rangle$$

$$\tan \theta = \frac{3}{5} \quad \text{and} \quad \theta = \tan^{-1} \frac{3}{5} \approx 31^\circ$$

Since \mathbf{b} is in quadrant I, $\theta \approx 31^\circ$.

Find the angle between $\mathbf{u} = \langle -2, 1 \rangle$ and $\mathbf{v} = \langle 3, -4 \rangle$.

We first find $\mathbf{u} \cdot \mathbf{v}$, $|\mathbf{u}|$, and $|\mathbf{v}|$:

$$\mathbf{u} \cdot \mathbf{v} = (-2) \cdot 3 + 1 \cdot (-4) = -10,$$

$$|\mathbf{u}| = \sqrt{(-2)^2 + 1^2} = \sqrt{5}, \quad \text{and}$$

$$|\mathbf{v}| = \sqrt{3^2 + (-4)^2} = \sqrt{25} = 5.$$

Then

$$\cos \theta = \frac{\mathbf{u} \cdot \mathbf{v}}{|\mathbf{u}| |\mathbf{v}|} = \frac{-10}{\sqrt{5} \cdot 5}$$

$$\theta = \cos^{-1} \left(\frac{-10}{\sqrt{5} \cdot 5} \right) \approx 153.4^\circ.$$

A 600-lb block is suspended by two cables as shown. At point B , there are three forces acting: \mathbf{R} , \mathbf{S} , and \mathbf{W} . Find the tension in each cable.

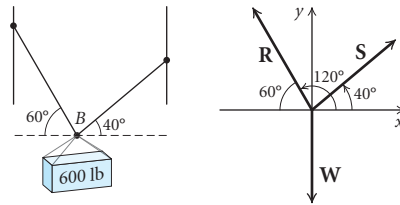

We have

$$\mathbf{R} = |\mathbf{R}|[(\cos 120^\circ)\mathbf{i} + (\sin 120^\circ)\mathbf{j}],$$

$$\mathbf{S} = |\mathbf{S}|[(\cos 40^\circ)\mathbf{i} + (\sin 40^\circ)\mathbf{j}], \quad \text{and}$$

$$\mathbf{W} = 600[(\cos 270^\circ)\mathbf{i} + (\sin 270^\circ)\mathbf{j}] = -600\mathbf{j}.$$

For a balance, the vector sum must be the vector \mathbf{O} :

$$\mathbf{R} + \mathbf{S} + \mathbf{W} = \mathbf{O}.$$

$$|\mathbf{R}|[(\cos 120^\circ)\mathbf{i} + (\sin 120^\circ)\mathbf{j}] + |\mathbf{S}|[(\cos 40^\circ)\mathbf{i} + (\sin 40^\circ)\mathbf{j}] - 600\mathbf{j} = 0\mathbf{i} + 0\mathbf{j}$$

This gives us two equations:

$$|\mathbf{R}|(\cos 120^\circ) + |\mathbf{S}|(\cos 40^\circ) = 0,$$

$$|\mathbf{R}|(\sin 120^\circ) + |\mathbf{S}|(\sin 40^\circ) - 600 = 0.$$

Solving this system of equations for $|\mathbf{R}|$ and $|\mathbf{S}|$, we get $|\mathbf{R}| \approx 467$ and $|\mathbf{S}| \approx 305$. The tensions in the cables are 467 lb and 305 lb.

Raise the number to the given power and write standard notation for the answer. [8.3]

$$35. (1 + i)^6 \qquad 36. \left(\frac{1}{2} + \frac{\sqrt{3}}{2}i\right)^{10}$$

37. Find the square roots of $-1 + i$. [8.3]

38. Find the cube roots of $3\sqrt{3} - 3i$. [8.3]

39. Find and graph the fourth roots of 81. [8.3]

40. Find and graph the fifth roots of 1. [8.3]

Find all the complex solutions of the equation. [8.3]

$$41. x^4 - i = 0 \qquad 42. x^3 + 1 = 0$$

43. Find the polar coordinates of each of these points. Give three answers for each point. [8.4]

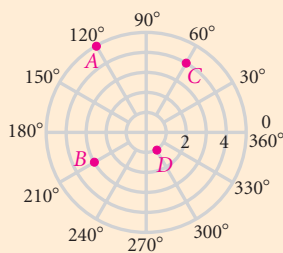

Find the polar coordinates of the point. Express the answer in degrees and then in radians. [8.4]

$$44. (-4\sqrt{2}, 4\sqrt{2}) \qquad 45. (0, -5)$$

Convert from rectangular coordinates to polar coordinates. Express the answer in degrees and then in radians. [8.4]

$$46. (-2, 5) \qquad 47. (-4.2, \sqrt{7})$$

Find the rectangular coordinates of the point. [8.4]

$$48. \left(3, \frac{\pi}{4}\right) \qquad 49. (-6, -120^\circ)$$

Convert from polar coordinates to rectangular coordinates. Round the coordinates to the nearest hundredth. [8.4]

$$50. (2, -15^\circ) \qquad 51. \left(-2.3, \frac{\pi}{5}\right)$$

Convert to a polar equation. [8.4]

$$52. 5x - 2y = 6 \qquad 53. y = 3$$

$$54. x^2 + y^2 = 9 \qquad 55. y^2 - 4x - 16 = 0$$

Convert to a rectangular equation. [8.4]

$$56. r = 6 \qquad 57. r + r \sin \theta = 1$$

$$58. r = \frac{3}{1 - \cos \theta} \qquad 59. r - 2 \cos \theta = 3 \sin \theta$$

In Exercises 60–63, match the equation with one of figures (a)–(d), which follow. [8.4]

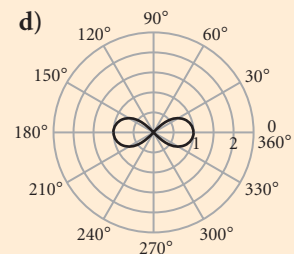
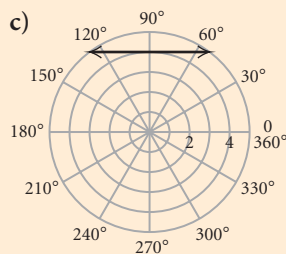
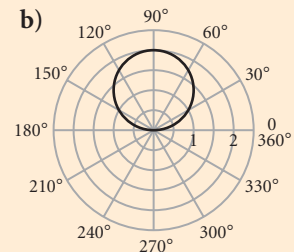
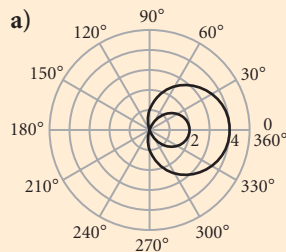

$$60. r = 2 \sin \theta$$

$$61. r^2 = \cos 2\theta$$

$$62. r = 1 + 3 \cos \theta$$

$$63. r \sin \theta = 4$$

Magnitudes of vectors \mathbf{u} and \mathbf{v} and the angle θ between the vectors are given. Find the magnitude of the sum, $\mathbf{u} + \mathbf{v}$, to the nearest tenth and give the direction by specifying to the nearest degree the angle that it makes with the vector \mathbf{u} . [8.5]

$$64. |\mathbf{u}| = 12, |\mathbf{v}| = 15, \theta = 120^\circ$$

$$65. |\mathbf{u}| = 41, |\mathbf{v}| = 60, \theta = 25^\circ$$

The vectors \mathbf{u} , \mathbf{v} , and \mathbf{w} are drawn below. Copy them on a sheet of paper. Then sketch each of the vectors in Exercises 66 and 67. [8.5]

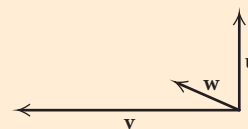

$$66. \mathbf{u} - \mathbf{v}$$

$$67. \mathbf{u} + \frac{1}{2}\mathbf{w}$$

68. Forces of 230 N and 500 N act on an object. The angle between the forces is 52° . Find the resultant, giving the angle that it makes with the smaller force. [8.5]
69. *Wind.* A wind has an easterly component of 15 km/h and a southerly component of 25 km/h. Find the magnitude and the direction of the wind. [8.5]
70. *Ship.* A ship sails $N75^\circ E$ for 90 nautical mi, and then $S10^\circ W$ for 100 nautical mi. How far is the ship, then, from the starting point, and in what direction? [8.5]

Find the component form of the vector given the initial and terminal points. [8.6]

71. \overrightarrow{AB} ; $A(2, -8)$, $B(-2, -5)$
72. \overrightarrow{TR} ; $R(0, 7)$, $T(-2, 13)$
73. Find the magnitude of vector \mathbf{u} if $\mathbf{u} = \langle 5, -6 \rangle$. [8.6]

Do the calculations in Exercises 74–77 for the vectors

$$\mathbf{u} = \langle 3, -4 \rangle, \quad \mathbf{v} = \langle -3, 9 \rangle, \quad \text{and} \quad \mathbf{w} = \langle -2, -5 \rangle. \quad [8.6]$$

74. $4\mathbf{u} + \mathbf{w}$
75. $2\mathbf{w} - 6\mathbf{v}$
76. $|\mathbf{u}| + |2\mathbf{w}|$
77. $\mathbf{u} \cdot \mathbf{w}$
78. Find a unit vector that has the same direction as $\mathbf{v} = \langle -6, -2 \rangle$. [8.6]
79. Express the vector $\mathbf{t} = \langle -9, 4 \rangle$ as a linear combination of the unit vectors \mathbf{i} and \mathbf{j} . [8.6]
80. Determine the direction angle θ of the vector $\mathbf{w} = \langle -4, -1 \rangle$ to the nearest degree. [8.6]
81. Find the magnitude and the direction angle θ of $\mathbf{u} = -5\mathbf{i} - 3\mathbf{j}$. [8.6]
82. Find the angle between $\mathbf{u} = \langle 3, -7 \rangle$ and $\mathbf{v} = \langle 2, 2 \rangle$ to the nearest tenth of a degree. [8.6]
83. *Airplane.* An airplane has an airspeed of 160 mph. It is to make a flight in a direction of 80° while there is a 20-mph wind from 310° . What will the airplane's actual heading be? [8.6]

Do the calculations in Exercises 84–87 for the vectors

$$\mathbf{u} = 2\mathbf{i} + 5\mathbf{j}, \quad \mathbf{v} = -3\mathbf{i} + 10\mathbf{j}, \quad \text{and} \quad \mathbf{w} = 4\mathbf{i} + 7\mathbf{j}. \quad [8.6]$$

84. $5\mathbf{u} - 8\mathbf{v}$

85. $\mathbf{u} - (\mathbf{v} + \mathbf{w})$

86. $|\mathbf{u} - \mathbf{v}|$

87. $3|\mathbf{w}| + |\mathbf{v}|$

88. Express the vector \overrightarrow{PQ} in the form $a\mathbf{i} + b\mathbf{j}$, if P is the point $(1, -3)$ and Q is the point $(-4, 2)$. [8.6]

Express each vector in Exercises 89 and 90 in the form $a\mathbf{i} + b\mathbf{j}$ and sketch each in the coordinate plane. [8.6]

89. The unit vectors $\mathbf{u} = (\cos \theta)\mathbf{i} + (\sin \theta)\mathbf{j}$ for $\theta = \pi/4$ and $\theta = 5\pi/4$. Include the unit circle $x^2 + y^2 = 1$ in your sketch.
90. The unit vector obtained by rotating \mathbf{j} counterclockwise $2\pi/3$ radians about the origin.
91. Express the vector $3\mathbf{i} - \mathbf{j}$ as a product of its magnitude and its direction.
92. Determine the trigonometric notation for $1 - i$. [8.3]
- A. $\sqrt{2} \left(\cos \frac{5\pi}{4} + i \sin \frac{5\pi}{4} \right)$
- B. $\sqrt{2} \left(\cos \frac{7\pi}{4} - i \sin \frac{7\pi}{4} \right)$
- C. $\cos \frac{7\pi}{4} + i \sin \frac{7\pi}{4}$
- D. $\sqrt{2} \left(\cos \frac{7\pi}{4} + i \sin \frac{7\pi}{4} \right)$
93. Convert the polar equation $r = 100$ to a rectangular equation. [8.4]
- A. $x^2 + y^2 = 10,000$
- B. $x^2 + y^2 = 100$
- C. $\sqrt{x^2 + y^2} = 10$
- D. $\sqrt{x^2 + y^2} = 1000$

94. The graph of $r = 1 - 2 \cos \theta$ is which of the following? [8.4]

A.

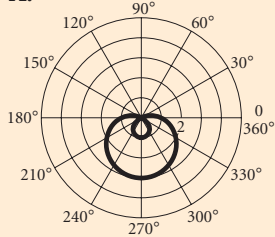

B.

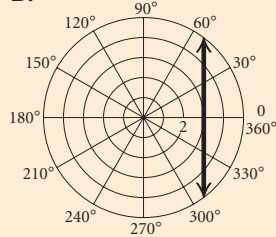

C.

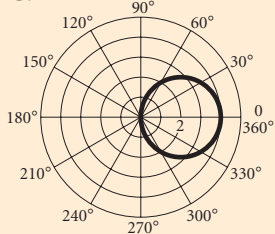

D.

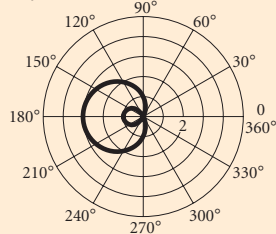

Collaborative Discussion and Writing

97. Summarize how you can tell algebraically when solving triangles whether there is no solution, one solution, or two solutions. [8.1], [8.2]
98. Give an example of an equation that is easier to graph in polar notation than in rectangular notation and explain why. [8.4]
99. Explain why the rectangular coordinates of a point are unique and the polar coordinates of a point are not unique. [8.4]
100. Explain why vectors \overrightarrow{QR} and \overrightarrow{RQ} are not equivalent. [8.5]
101. Explain how unit vectors are related to the unit circle. [8.6]
102. Write a vector sum problem for a classmate for which the answer is $\mathbf{v} = 5\mathbf{i} - 8\mathbf{j}$. [8.6]

Synthesis

95. Let $\mathbf{u} = 12\mathbf{i} + 5\mathbf{j}$. Find a vector that has the same direction as \mathbf{u} but has length 3. [8.6]
96. A parallelogram has sides of lengths 3.42 and 6.97. Its area is 18.4. Find the sizes of its angles. [8.1]

Chapter 8 Test

Solve $\triangle ABC$, if possible.

- $a = 18$ ft, $B = 54^\circ$, $C = 43^\circ$
- $b = 8$ m, $c = 5$ m, $C = 36^\circ$
- $a = 16.1$ in., $b = 9.8$ in., $c = 11.2$ in.
- Find the area of $\triangle ABC$ if $C = 106.4^\circ$, $a = 7$ cm, and $b = 13$ cm.
- Distance Across a Lake.** Points A and B are on opposite sides of a lake. Point C is 52 m from A . The measure of $\angle BAC$ is determined to be 108° , and the measure of $\angle ACB$ is determined to be 44° . What is the distance from A to B ?
- Location of Airplanes.** Two airplanes leave an airport at the same time. The first flies 210 km/h in a direction of 290° . The second flies 180 km/h in a direction of 185° . After 3 hr, how far apart are the planes?
- Graph: $-4 + i$.
- Find the absolute value of $2 - 3i$.
- Find trigonometric notation for $3 - 3i$.
- Divide and express the result in standard notation $a + bi$:

$$\frac{2 \left(\cos \frac{2\pi}{3} + i \sin \frac{2\pi}{3} \right)}{8 \left(\cos \frac{\pi}{6} + i \sin \frac{\pi}{6} \right)}$$
- Find $(1 - i)^8$ and write standard notation for the answer.
- Find the polar coordinates of $(-1, \sqrt{3})$. Express the angle in degrees using the smallest possible positive angle.
- Convert $\left(-1, \frac{2\pi}{3}\right)$ to rectangular coordinates.

14. Convert to a polar equation: $x^2 + y^2 = 10$.

15. Graph: $r = 1 - \cos \theta$.

16. For vectors \mathbf{u} and \mathbf{v} , $|\mathbf{u}| = 8$, $|\mathbf{v}| = 5$, and the angle between the vectors is 63° . Find $\mathbf{u} + \mathbf{v}$. Give the magnitude to the nearest tenth, and give the direction by specifying the angle that the resultant makes with \mathbf{u} , to the nearest degree.

17. For $\mathbf{u} = 2\mathbf{i} - 7\mathbf{j}$ and $\mathbf{v} = 5\mathbf{i} + \mathbf{j}$, find $2\mathbf{u} - 3\mathbf{v}$.

18. Find a unit vector in the same direction as $-4\mathbf{i} + 3\mathbf{j}$.

19. Which of the following is the graph of $r = 3 \cos \theta$?

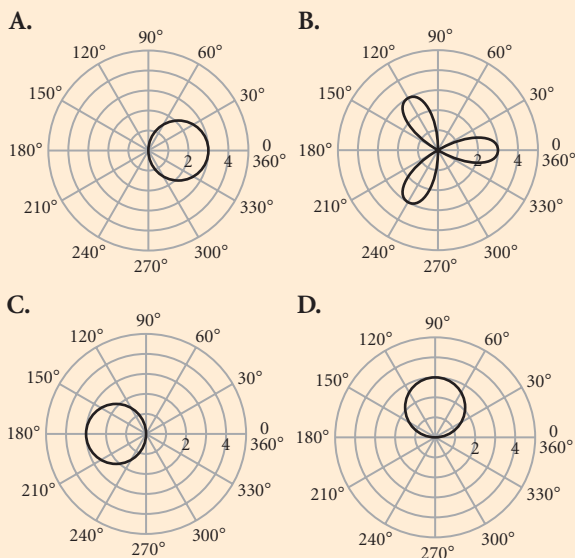

Synthesis

20. A parallelogram has sides of length 15.4 and 9.8. Its area is 72.9. Find the measures of the angles.

This page intentionally left blank

Systems of Equations and Matrices

CHAPTER

9

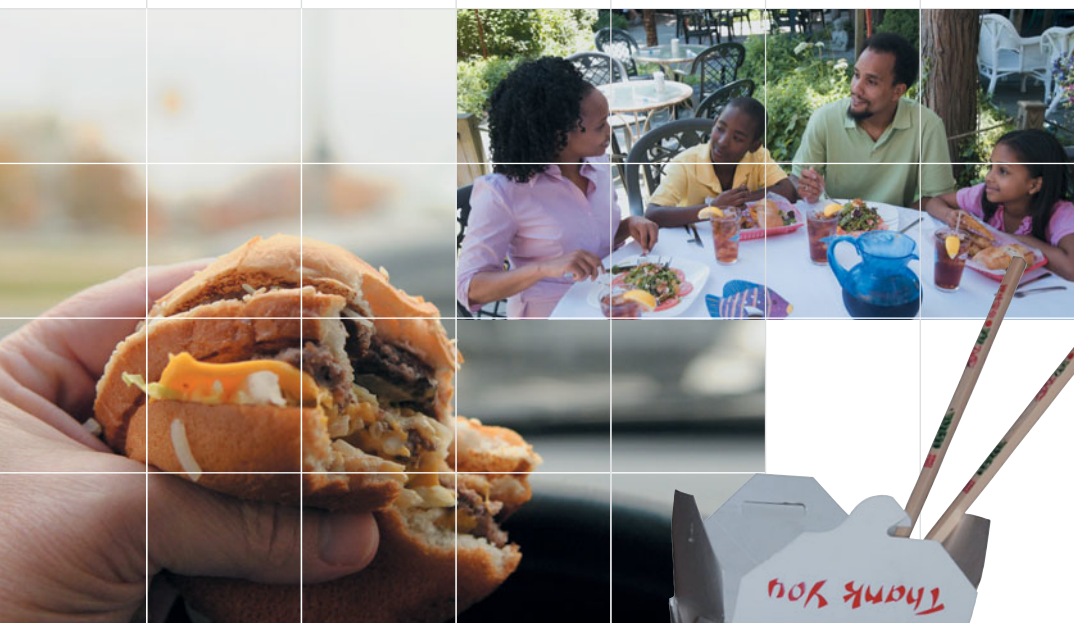

Application

The total number of restaurant-purchased meals that the average person will eat in a restaurant, in a car, or at home in a year is 170. The total number of these meals eaten in a car or at home exceeds the number eaten in a restaurant by 14. Twenty more restaurant-purchased meals will be eaten in a restaurant than at home. (Source: The NPD Group) Find the number of restaurant-purchased meals eaten in a restaurant, the number eaten in a car, and the number eaten at home.

This problem appears as Exercise 19 in Section 9.2.

9.1 Systems of Equations in Two Variables

Visualizing the Graph

9.2 Systems of Equations in Three Variables

9.3 Matrices and Systems of Equations

9.4 Matrix Operations

Mid-Chapter Mixed Review

9.5 Inverses of Matrices

9.6 Determinants and Cramer's Rule

9.7 Systems of Inequalities and Linear Programming

9.8 Partial Fractions

Study Guide

Review Exercises

Chapter Test

Systems of Equations in Two Variables

9.1

- ▶ Solve a system of two linear equations in two variables by graphing.
- ▶ Solve a system of two linear equations in two variables using the substitution method and the elimination method.
- ▶ Use systems of two linear equations to solve applied problems.

A **system of equations** is composed of two or more equations considered simultaneously. For example,

$$\begin{aligned}x - y &= 5, \\2x + y &= 1\end{aligned}$$

is a **system of two linear equations in two variables**. The solution set of this system consists of all ordered pairs that make *both* equations true. The ordered pair $(2, -3)$ is a solution of the system of equations above. We can verify this by substituting 2 for x and -3 for y in *each* equation.

$$\begin{array}{r|l} x - y = 5 & \\ \hline 2 - (-3) & ? \quad 5 \\ 2 + 3 & | \\ 5 & 5 \quad \text{TRUE} \end{array} \qquad \begin{array}{r|l} 2x + y = 1 & \\ \hline 2 \cdot 2 + (-3) & ? \quad 1 \\ 4 - 3 & | \\ 1 & 1 \quad \text{TRUE} \end{array}$$

▶ Solving Systems of Equations Graphically

Recall that the graph of a linear equation is a line that contains all the ordered pairs in the solution set of the equation. When we graph a system of linear equations, each point at which the graphs intersect is a solution of *both* equations and therefore a **solution of the system of equations**.

EXAMPLE 1 Solve the following system of equations graphically.

$$\begin{aligned}x - y &= 5, \\2x + y &= 1\end{aligned}$$

Solution We graph the equations on the same set of axes, as shown below.

TECHNOLOGY CONNECTION

To use a graphing calculator to solve this system of equations, it might be necessary to write each equation in “ $Y = \dots$ ” form. If so, we would graph $y_1 = x - 5$ and $y_2 = -2x + 1$ and then use the INTERSECT feature. We see that the solution is $(2, -3)$.

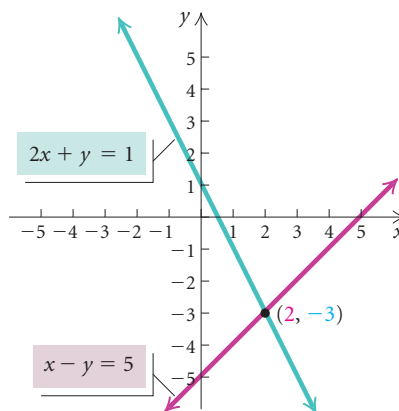
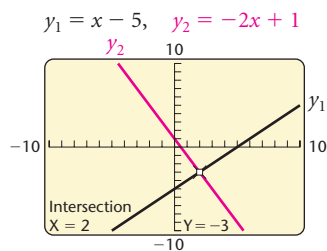

We see that the graphs intersect at a single point, $(2, -3)$, so $(2, -3)$ is the solution of the system of equations. To check this solution, we substitute 2 for x and -3 for y in both equations as we did above.

➔ **Now Try Exercise 7.**

The graphs of most of the systems of equations that we use to model applications intersect at a single point, like the system above. However, it is possible that the graphs will have no points in common or infinitely many points in common. Each of these possibilities is illustrated below.

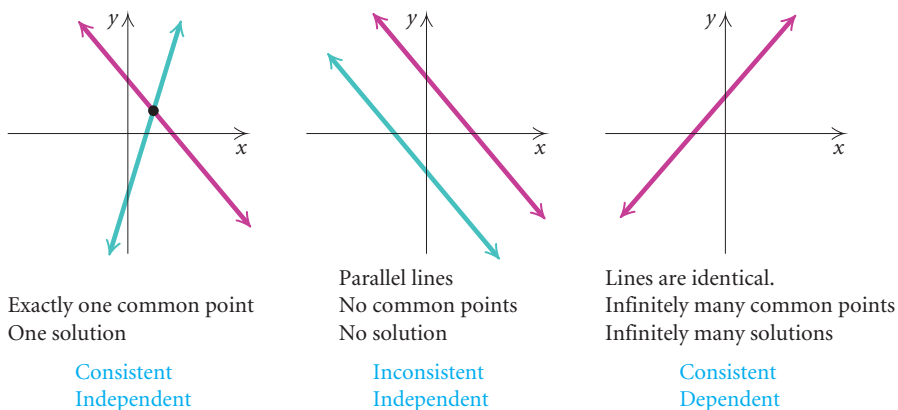

If a system of equations has at least one solution, it is **consistent**. If the system has no solutions, it is **inconsistent**. In addition, for a system of two linear equations in two variables, if one equation can be obtained by multiplying both sides of the other equation by a constant, the equations are **dependent**. Otherwise, they are **independent**. A system of two dependent linear equations in two variables has an infinite number of solutions.

► The Substitution Method

Solving a system of equations graphically is not always accurate when the solutions are not integers. A solution like $(\frac{43}{27}, -\frac{19}{27})$, for instance, will be difficult to determine from a hand-drawn graph.

Algebraic methods for solving systems of equations, when used correctly, always give accurate results. One such technique is the **substitution method**. It is used most often when a variable is alone on one side of an equation or when it is easy to solve for a variable. To apply the substitution method, we begin by using one of the equations to express one variable in terms of the other; then we substitute that expression in the other equation of the system.

EXAMPLE 2 Use the substitution method to solve the system

$$x - y = 5, \quad (1)$$

$$2x + y = 1. \quad (2)$$

Solution First, we solve equation (1) for x . (We could have solved for y instead.) We have

$$x - y = 5, \quad (1)$$

$$x = y + 5. \quad \text{Solving for } x$$

Then we substitute $y + 5$ for x in equation (2). This gives an equation in one variable, which we know how to solve:

$$2x + y = 1 \quad (2)$$

$$2(y + 5) + y = 1 \quad \text{The parentheses are necessary.}$$

$$2y + 10 + y = 1 \quad \text{Removing parentheses}$$

$$3y + 10 = 1 \quad \text{Collecting like terms on the left}$$

$$3y = -9 \quad \text{Subtracting 10 on both sides}$$

$$y = -3. \quad \text{Dividing by 3 on both sides}$$

Now we substitute -3 for y in either of the original equations (this is called **back-substitution**) and solve for x . We choose equation (1):

$$x - y = 5, \quad (1)$$

$$x - (-3) = 5 \quad \text{Substituting } -3 \text{ for } y$$

$$x + 3 = 5$$

$$x = 2. \quad \text{Subtracting 3 on both sides}$$

We have previously checked the pair $(2, -3)$ in both equations. The solution of the system of equations is $(2, -3)$.  **Now Try Exercise 17.**

► The Elimination Method

Another algebraic technique for solving systems of equations is the **elimination method**. With this method, we eliminate a variable by adding two equations. If the coefficients of a particular variable are opposites, we can eliminate that variable simply by adding the original equations. For example, if the x -coefficient is -3 in one equation and is 3 in the other equation, then the sum of the x -terms will be 0 and thus the variable x will be eliminated when we add the equations.

EXAMPLE 3 Use the elimination method to solve the system of equations

$$2x + y = 2, \quad (1)$$

$$x - y = 7. \quad (2)$$

Algebraic Solution

Since the y -coefficients, 1 and -1 , are opposites, we can eliminate y by adding the equations:

$$2x + y = 2 \quad (1)$$

$$\underline{x - y = 7} \quad (2)$$

$$3x = 9 \quad \text{Adding}$$

$$x = 3.$$

We then back-substitute 3 for x in either equation and solve for y .

We choose equation (1):

$$2x + y = 2 \quad (1)$$

$$2 \cdot 3 + y = 2 \quad \text{Substituting 3 for } x$$

$$6 + y = 2$$

$$y = -4.$$

We check the solution by substituting the pair $(3, -4)$ in both equations.

$$\begin{array}{r|l} 2x + y = 2 & \\ \hline 2 \cdot 3 + (-4) & ? 2 \\ 6 - 4 & \\ \hline 2 & 2 \quad \text{TRUE} \end{array}$$

$$\begin{array}{r|l} x - y = 7 & \\ \hline 3 - (-4) & ? 7 \\ 3 + 4 & \\ \hline 7 & 7 \quad \text{TRUE} \end{array}$$

The solution is $(3, -4)$. Since there is exactly one solution, the system of equations is consistent, and the equations are independent.

Visualizing the Solution

We graph $2x + y = 2$ and $x - y = 7$.

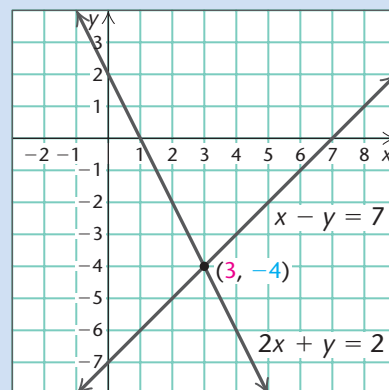

The graphs intersect at the point $(3, -4)$, so the solution of the system of equations is $(3, -4)$.

Now Try Exercise 31.

Before we add, it might be necessary to multiply one or both equations by suitable constants in order to find two equations in which the coefficients of a variable are opposites.

EXAMPLE 4 Use the elimination method to solve the system of equations

$$4x + 3y = 11, \quad (1)$$

$$-5x + 2y = 15. \quad (2)$$

Algebraic Solution

We can obtain x -coefficients that are opposites by multiplying the first equation by 5 and the second equation by 4:

$$\begin{array}{rcl} 20x + 15y = 55 & \text{Multiplying equation (1) by 5} \\ -20x + 8y = 60 & \text{Multiplying equation (2) by 4} \\ \hline 23y = 115 & \text{Adding} \\ y = 5. & \end{array}$$

We then back-substitute 5 for y in either equation (1) or (2) and solve for x . We choose equation (1):

$$\begin{array}{rcl} 4x + 3y = 11 & (1) \\ 4x + 3 \cdot 5 = 11 & \text{Substituting 5 for } y \\ 4x + 15 = 11 \\ 4x = -4 \\ x = -1. \end{array}$$

We can check the pair $(-1, 5)$ by substituting in both equations. The solution is $(-1, 5)$. The system of equations is consistent, and the equations are independent.

Visualizing the Solution

We graph $4x + 3y = 11$ and $-5x + 2y = 15$.

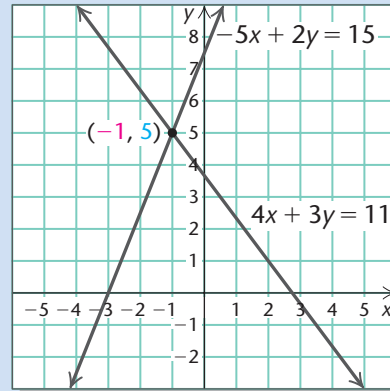

The graphs intersect at the point $(-1, 5)$, so the solution of the system of equations is $(-1, 5)$.

 Now Try Exercise 33.

In Example 4, the two systems

$$\begin{array}{l} 4x + 3y = 11, \quad 20x + 15y = 55, \\ -5x + 2y = 15 \quad \text{and} \quad -20x + 8y = 60 \end{array}$$

are **equivalent** because they have exactly the same solutions. When we use the elimination method, we often multiply one or both equations by constants to find equivalent equations that allow us to eliminate a variable by adding.

EXAMPLE 5 Solve each of the following systems using the elimination method.

$$\begin{array}{ll} \text{a)} & x - 3y = 1, \quad (1) \\ & -2x + 6y = 5 \quad (2) \end{array} \qquad \begin{array}{ll} \text{b)} & 2x + 3y = 6, \quad (1) \\ & 4x + 6y = 12 \quad (2) \end{array}$$

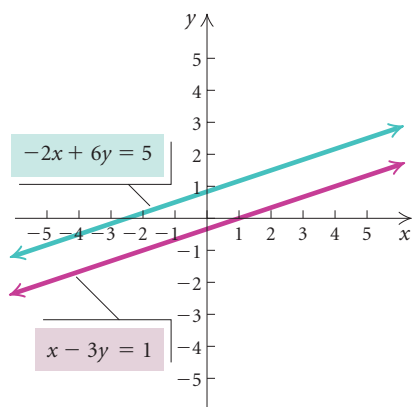

Figure 1

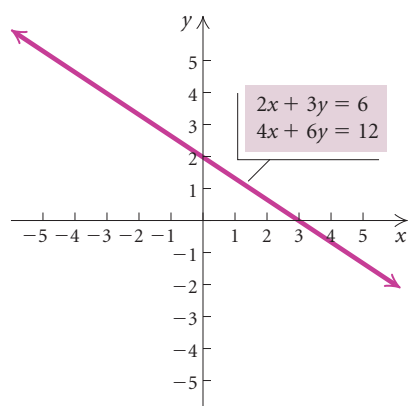

Figure 2

x	$-\frac{2}{3}x + 2$
$-\frac{3}{2}y + 3$	y
-3	4
0	2
6	-2

Solution

- a) We multiply equation (1) by 2 and add:

$$\begin{array}{r} 2x - 6y = 2 \quad \text{Multiplying equation (1) by 2} \\ -2x + 6y = 5 \quad (2) \\ \hline 0 = 7. \quad \text{Adding} \end{array}$$

There are no values of x and y for which $0 = 7$ is true, so the system has *no solution*. The solution set is \emptyset . The system of equations is inconsistent and the equations are independent. The graphs of the equations are parallel lines, as shown in Fig. 1.

- b) We multiply equation (1) by -2 and add:

$$\begin{array}{r} -4x - 6y = -12 \quad \text{Multiplying equation (1) by } -2 \\ 4x + 6y = 12 \quad (2) \\ \hline 0 = 0. \quad \text{Adding} \end{array}$$

We obtain the equation $0 = 0$, which is true for all values of x and y . This tells us that the equations are dependent, so there are *infinitely many solutions*. That is, any solution of one equation of the system is also a solution of the other. The system of equations is consistent. The graphs of the equations are identical, as shown in Fig. 2.

Solving either equation for y , we have $y = -\frac{2}{3}x + 2$, so we can write the solutions of the system as ordered pairs (x, y) , where y is expressed as $-\frac{2}{3}x + 2$. Thus the solutions can be written in the form $(x, -\frac{2}{3}x + 2)$. Any real value that we choose for x then gives us a value for y and thus an ordered pair in the solution set. For example,

$$\begin{array}{ll} \text{if } x = -3, & \text{then } -\frac{2}{3}x + 2 = -\frac{2}{3}(-3) + 2 = 4, \\ \text{if } x = 0, & \text{then } -\frac{2}{3}x + 2 = -\frac{2}{3} \cdot 0 + 2 = 2, \quad \text{and} \\ \text{if } x = 6, & \text{then } -\frac{2}{3}x + 2 = -\frac{2}{3} \cdot 6 + 2 = -2. \end{array}$$

Thus some of the solutions are $(-3, 4)$, $(0, 2)$, and $(6, -2)$.

Similarly, solving either equation for x , we have $x = -\frac{3}{2}y + 3$, so the solutions (x, y) can also be written, expressing x as $-\frac{3}{2}y + 3$, in the form $(-\frac{3}{2}y + 3, y)$.

Since the two forms of the solutions are equivalent, they yield the same solution set, as illustrated in the table at left. Note, for example, that when $y = 4$, we have the solution $(-3, 4)$; when $y = 2$, we have $(0, 2)$; and when $y = -2$, we have $(6, -2)$.

 Now Try Exercises 35 and 37.

► Applications

Frequently the most challenging and time-consuming step in the problem-solving process is translating a situation to mathematical language. However, in many cases, this task is made easier if we translate to more than one equation in more than one variable.



EXAMPLE 6 *Snack Mixtures.* At Max's Munchies, caramel corn worth \$2.50 per pound is mixed with honey roasted mixed nuts worth \$7.50 per pound in order to get 20 lb of a mixture worth \$4.50 per pound. How much of each snack is used?

Solution We use the five-step problem-solving process.

1. Familiarize. Let's begin by making a guess. Suppose 16 lb of caramel corn and 4 lb of nuts are used. Then the total weight of the mixture would be $16 \text{ lb} + 4 \text{ lb}$, or 20 lb, the desired weight. The total values of these amounts of ingredients are found by multiplying the price per pound by the number of pounds used:

$$\begin{array}{rcl} \text{Caramel corn:} & \$2.50(16) & = \$40 \\ \text{Nuts:} & \$7.50(4) & = \underline{\$30} \\ \text{Total value:} & & \$70. \end{array}$$

The desired value of the mixture is \$4.50 per pound, so the value of 20 lb would be $\$4.50(20)$, or \$90. Thus we see that our guess, which led to a total of \$70, is incorrect. Nevertheless, these calculations will help us to translate.

2. Translate. We organize the information in a table. We let x = the number of pounds of caramel corn in the mixture and y = the number of pounds of nuts.

	Caramel Corn	Nuts	Mixture
Price per Pound	\$2.50	\$7.50	\$4.50
Number of Pounds	x	y	20
Value of Mixture	$2.50x$	$7.50y$	$4.50(20)$, or 90

$$\rightarrow x + y = 20$$

$$\rightarrow 2.50x + 7.50y = 90$$

From the second row of the table, we get one equation:

$$x + y = 20.$$

The last row of the table yields a second equation:

$$2.50x + 7.50y = 90, \text{ or } 2.5x + 7.5y = 90.$$

We can multiply by 10 on both sides of the second equation to clear the decimals. This gives us the following system of equations:

$$x + y = 20, \quad (1)$$

$$25x + 75y = 900. \quad (2)$$

3. Carry out. We carry out the solution as follows.

Algebraic Solution

Using the elimination method, we multiply equation (1) by -25 and add it to equation (2):

$$\begin{array}{r} -25x - 25y = -500 \\ 25x + 75y = 900 \\ \hline 50y = 400 \\ y = 8. \end{array}$$

Then we back-substitute to find x :

$$\begin{array}{r} x + y = 20 \quad (1) \\ x + 8 = 20 \quad \text{Substituting 8 for } y \\ x = 12. \end{array}$$

The solution is $(12, 8)$.

Visualizing the Solution

The solution of the system of equations is the point of intersection of the graphs of the equations.

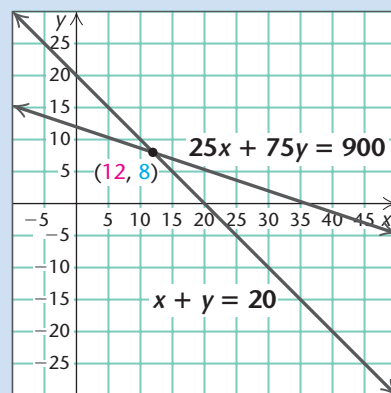

The graphs intersect at the point $(12, 8)$, so the solution of the system of equations is $(12, 8)$.

- 4. Check.** If 12 lb of caramel corn and 8 lb of nuts are used, the mixture weighs $12 + 8$, or 20 lb. The value of the mixture is $\$2.50(12) + \$7.50(8)$, or $\$30 + \60 , or $\$90$. Since the possible solution yields the desired weight and value of the mixture, our result checks.
- 5. State.** The mixture should consist of 12 lb of caramel corn and 8 lb of honey roasted mixed nuts.

Now Try Exercise 61.

EXAMPLE 7 Airplane Travel. An airplane flies the 3000-mi distance from Los Angeles to New York, with a tailwind, in 5 hr. The return trip, against the wind, takes 6 hr. Find the speed of the airplane and the speed of the wind.

Solution

1. **Familiarize.** We first make a drawing, letting p = the speed of the plane, in miles per hour, and w = the speed of the wind, also in miles per hour. When the plane is traveling with a tailwind, the wind increases the speed of the plane, so the speed with the tailwind is $p + w$. On the other hand, the headwind slows the plane down, so the speed with the headwind is $p - w$.

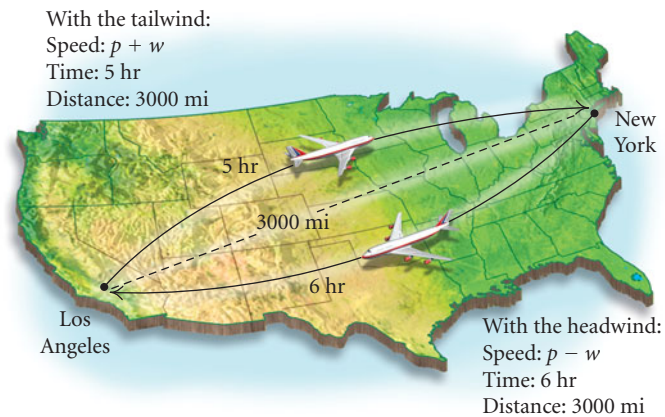

2. **Translate.** We organize the information in a table. Using the formula $Distance = Rate \text{ (or Speed)} \cdot Time$, we find that each row of the table yields an equation.

	Distance	Rate	Time	
With Tailwind	3000	$p + w$	5	$\rightarrow 3000 = (p + w)5$
With Headwind	3000	$p - w$	6	$\rightarrow 3000 = (p - w)6$

We now have a system of equations:

$$3000 = (p + w)5, \quad \text{or} \quad 600 = p + w, \quad (1) \quad \text{Dividing by 5}$$

$$3000 = (p - w)6, \quad \text{or} \quad 500 = p - w. \quad (2) \quad \text{Dividing by 6}$$

3. **Carry out.** We use the elimination method:

$$600 = p + w \quad (1)$$

$$\underline{500 = p - w} \quad (2)$$

$$1100 = 2p \quad \text{Adding}$$

$$550 = p. \quad \text{Dividing by 2 on both sides}$$

Now we substitute in one of the equations to find w :

$$600 = p + w \quad (1)$$

$$600 = 550 + w \quad \text{Substituting 550 for } p$$

$$50 = w. \quad \text{Subtracting 550 on both sides}$$

4. **Check.** If $p = 550$ and $w = 50$, then the speed of the plane with the tailwind is $550 + 50$, or 600 mph, and the speed with the headwind is $550 - 50$, or 500 mph. At 600 mph, the time it takes to travel 3000 mi is $3000/600$, or 5 hr. At 500 mph, the time it takes to travel 3000 mi is $3000/500$, or 6 hr. The times check, so the answer is correct.
5. **State.** The speed of the plane is 550 mph, and the speed of the wind is 50 mph.  **Now Try Exercise 65.**

STUDY TIP

Make an effort to do your homework as soon as possible after each class. Make this part of your routine, choosing a time and a place where you can focus with a minimum of interruptions.

EXAMPLE 8 Supply and Demand. Suppose that the price and the supply of the Star Station satellite radio are related by the equation

$$y = 90 + 30x,$$

where y is the price, in dollars, at which the seller is willing to supply x thousand units. Also suppose that the price and the demand for the same model of satellite radio are related by the equation

$$y = 200 - 25x,$$

where y is the price, in dollars, at which the consumer is willing to buy x thousand units.

The **equilibrium point** for this radio is the pair (x, y) that is a solution of both equations. The **equilibrium price** is the price at which the amount of the product that the seller is willing to supply is the same as the amount demanded by the consumer. Find the equilibrium point for this radio.

Solution

1., 2. Familiarize and Translate. We are given a system of equations in the statement of the problem, so no further translation is necessary.

$$y = 90 + 30x, \quad (1)$$

$$y = 200 - 25x \quad (2)$$

We substitute some values for x in each equation to get an idea of the corresponding prices. When $x = 1$,

$$y = 90 + 30 \cdot 1 = 120, \quad \text{Substituting in equation (1)}$$

$$y = 200 - 25 \cdot 1 = 175. \quad \text{Substituting in equation (2)}$$

This indicates that the price when 1 thousand units are supplied is lower than the price when 1 thousand units are demanded.

When $x = 4$,

$$y = 90 + 30 \cdot 4 = 210, \quad \text{Substituting in equation (1)}$$

$$y = 200 - 25 \cdot 4 = 100. \quad \text{Substituting in equation (2)}$$

In this case, the price related to supply is higher than the price related to demand. It would appear that the x -value we are looking for is between 1 and 4.

3. Carry out. We use the substitution method:

$$y = 90 + 30x \quad \text{Equation (1)}$$

$$200 - 25x = 90 + 30x \quad \text{Substituting } 200 - 25x \text{ for } y$$

$$110 = 55x \quad \text{Adding } 25x \text{ and subtracting } 90 \text{ on both sides}$$

$$2 = x. \quad \text{Dividing by } 55 \text{ on both sides}$$

We now back-substitute 2 for x in either equation and find y :

$$y = 200 - 25x \quad (2)$$

$$y = 200 - 25 \cdot 2 \quad \text{Substituting } 2 \text{ for } x$$

$$y = 200 - 50$$

$$y = 150.$$

We can visualize the solution as the coordinates of the point of intersection of the graphs of the equations $y = 90 + 30x$ and $y = 200 - 25x$.

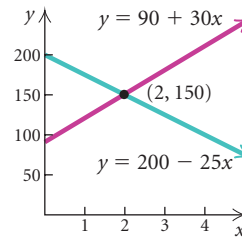

- 4. Check.** We can check by substituting 2 for x and 150 for y in both equations. Also note that 2 is between 1 and 4, as expected from the *Familiarize* and *Translate* steps.
- 5. State.** The equilibrium point is $(2, \$150)$. That is, the equilibrium quantity is 2 thousand units and the equilibrium price is \$150.

 **Now Try Exercise 69.**

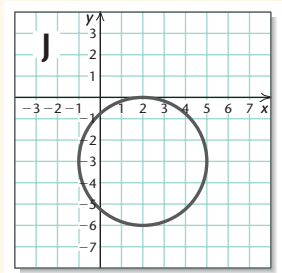
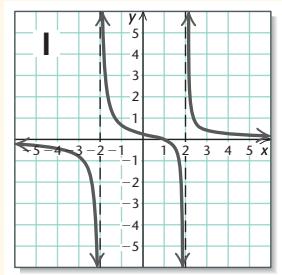
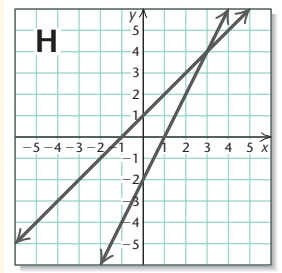
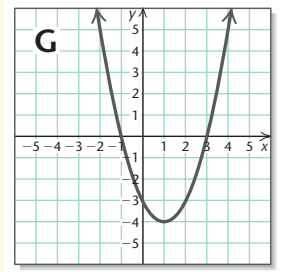
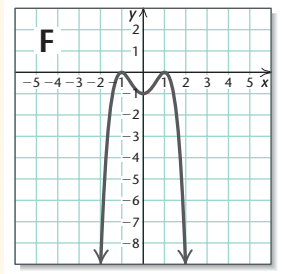
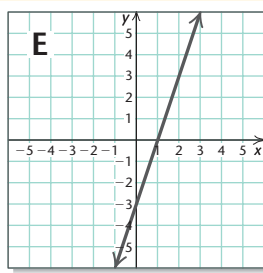
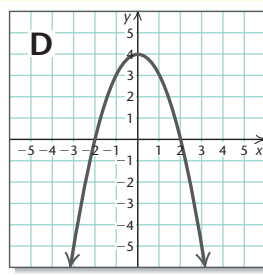
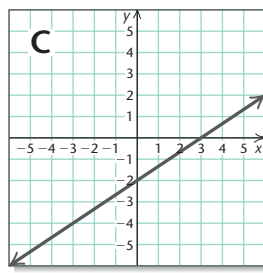
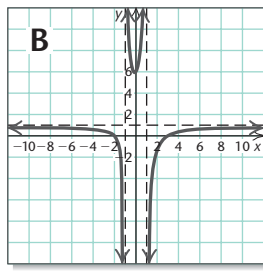
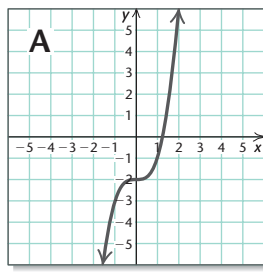

Visualizing the Graph

Match the equation or system of equations with its graph.

- $2x - 3y = 6$
- $f(x) = x^2 - 2x - 3$
- $f(x) = -x^2 + 4$
- $(x - 2)^2 + (y + 3)^2 = 9$
- $f(x) = x^3 - 2$
- $f(x) = -(x - 1)^2(x + 1)^2$
- $f(x) = \frac{x - 1}{x^2 - 4}$
- $f(x) = \frac{x^2 - x - 6}{x^2 - 1}$
- $x - y = -1,$
 $2x - y = 2$
- $3x - y = 3,$
 $2y = 6x - 6$

Answers on page A-56

9.1

Exercise Set

In Exercises 1–6, match the system of equations with one of the graphs (a)–(f), which follow.

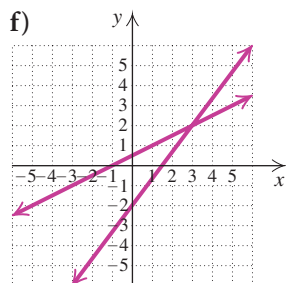
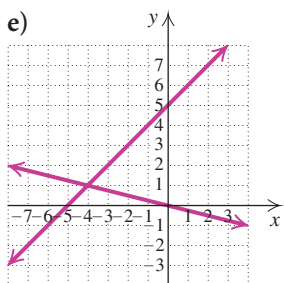
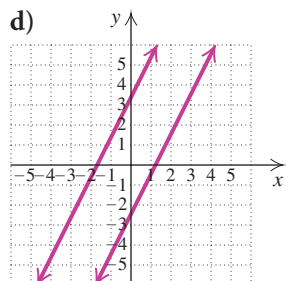
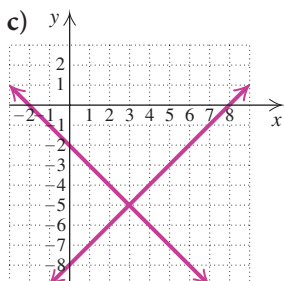
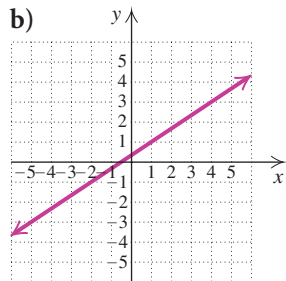
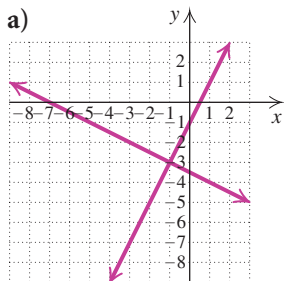

1. $x + y = -2$,
 $y = x - 8$

3. $x - 2y = -1$,
 $4x - 3y = 6$

5. $2x - 3y = -1$,
 $-4x + 6y = 2$

Solve graphically.

7. $x + y = 2$,
 $3x + y = 0$

9. $x + 2y = 1$,
 $x + 4y = 3$

11. $y + 1 = 2x$,
 $y - 1 = 2x$

2. $x - y = -5$,
 $x = -4y$

4. $2x - y = 1$,
 $x + 2y = -7$

6. $4x - 2y = 5$,
 $6x - 3y = -10$

8. $x + y = 1$,
 $3x + y = 7$

10. $3x + 4y = 5$,
 $x - 2y = 5$

12. $2x - y = 1$,
 $3y = 6x - 3$

13. $x - y = -6$,
 $y = -2x$

15. $2y = x - 1$,
 $3x = 6y + 3$

Solve using the substitution method.

17. $x + y = 9$,
 $2x - 3y = -2$

19. $x - 2y = 7$,
 $x = y + 4$

21. $y = 2x - 6$,
 $5x - 3y = 16$

23. $x + y = 3$,
 $y = 4 - x$

25. $x - 5y = 4$,
 $y = 7 - 2x$

27. $x + 2y = 2$,
 $4x + 4y = 5$

29. $3x - y = 5$,
 $3y = 9x - 15$

14. $2x + y = 5$,
 $x = -3y$

16. $y = 3x + 2$,
 $3x - y = -3$

18. $3x - y = 5$,
 $x + y = \frac{1}{2}$

20. $x + 4y = 6$,
 $x = -3y + 3$

22. $3x + 5y = 2$,
 $2x - y = -3$

24. $x - 2y = 3$,
 $2x = 4y + 6$

26. $5x + 3y = -1$,
 $x + y = 1$

28. $2x - y = 2$,
 $4x + y = 3$

30. $2x - y = 7$,
 $y = 2x - 5$

Solve using the elimination method. Also determine whether each system is consistent or inconsistent and whether the equations are dependent or independent.

31. $x + 2y = 7$,
 $x - 2y = -5$

32. $3x + 4y = -2$,
 $-3x - 5y = 1$

33. $x - 3y = 2$,
 $6x + 5y = -34$

34. $x + 3y = 0$,
 $20x - 15y = 75$

35. $3x - 12y = 6$,
 $2x - 8y = 4$

36. $2x + 6y = 7$,
 $3x + 9y = 10$

37. $4x - 2y = 3$,
 $2x - y = 4$

38. $6x + 9y = 12$,
 $4x + 6y = 8$

39. $2x = 5 - 3y$,
 $4x = 11 - 7y$

40. $7(x - y) = 14$,
 $2x = y + 5$

41. $0.3x - 0.2y = -0.9$,
 $0.2x - 0.3y = -0.6$

(Hint: Since each coefficient has one decimal place, first multiply each equation by 10 to clear the decimals.)

42. $0.2x - 0.3y = 0.3$,
 $0.4x + 0.6y = -0.2$
 (Hint: Since each coefficient has one decimal place, first multiply each equation by 10 to clear the decimals.)

43. $\frac{1}{5}x + \frac{1}{2}y = 6$,
 $\frac{3}{5}x - \frac{1}{2}y = 2$
 (Hint: First multiply by the least common denominator to clear fractions.)

44. $\frac{2}{3}x + \frac{3}{5}y = -17$,
 $\frac{1}{2}x - \frac{1}{3}y = -1$
 (Hint: First multiply by the least common denominator to clear fractions.)

In Exercises 45–50, determine whether the statement is true or false.

45. If the graph of a system of equations is a pair of parallel lines, the system of equations is inconsistent.

46. If we obtain the equation $0 = 0$ when using the elimination method to solve a system of equations, the system has no solution.

47. If a system of two linear equations in two variables is consistent, it has exactly one solution.

48. If a system of two linear equations in two variables is dependent, it has infinitely many solutions.

49. It is possible for a system of two linear equations in two variables to be consistent and dependent.

50. It is possible for a system of two linear equations in two variables to be inconsistent and dependent.

51. **Consumer Complaints.** The Better Business Bureau received the most complaints from consumers about cell-phone providers and cable/satellite TV providers in 2009. These two industries accounted for a total of 70,093 complaints, with cable/satellite TV providers receiving 4861 fewer complaints than cell-phone providers (Source: Better Business Bureau). How many complaints did each industry receive?

52. **Health-Care Costs.** It is projected that in 2018, the average total of medical bills for an obese adult will be \$2460 higher than the average for an adult with a healthy weight. Together, the average amount of medical bills for an obese adult and an adult with a healthy weight are projected to total \$14,170. (Source: Kenneth Thorpe, Emory University) Find the projected average amount of medical bills for an obese adult and for an adult with a healthy weight.

53. **Joint-Replacement Surgery.** It is estimated that in 2030, there will be a total of 4.072 million knee replacement and hip replacement surgeries, with knee replacements outnumbering hip replacements by 2.928 million (Source: *Indianapolis Star* research). Find the estimated number of each type of joint replacement.

54. **Street Names.** The two most common names for streets in the United States are Second Street and Main Street, with 15,684 streets bearing one of these names. There are 260 more streets named Second Street than Main Street. (Source: 2006 Tele Atlas digital map data) How many streets bear each name?

55. **Winter Sports Injuries.** Skiers and snowboarders suffer about 288,400 injuries each winter, with skiing accounting for about 400 more injuries than snowboarding (Source: U.S. Consumer Product Safety Commission). How many injuries occur in each winter sport?



56. **Added Sugar in Soft Drinks.** Together, a 20-fl oz Coca-Cola and a 20-fl oz Pepsi contain 34 tsp of added sugar. The Coca-Cola contains 1 tsp less of added sugar than the Pepsi. (Source: *Nutrition Action HealthLetter*, January/February, 2010) Find the amount of added sugar in each type of soft drink.



57. **Mail-Order Business.** A mail-order lacrosse equipment business shipped 120 packages one day. Customers are charged \$3.50 for each standard-delivery package and \$7.50 for each express-delivery package. Total shipping charges for the day were \$596. How many of each kind of package were shipped?
58. **Concert Ticket Prices.** One evening 1500 concert tickets were sold for the Fairmont Summer Jazz Festival. Tickets cost \$25 for a covered pavilion seat and \$15 for a lawn seat. Total receipts were \$28,500. How many of each type of ticket were sold?
59. **Investment.** Bernadette inherited \$15,000 and invested it in two municipal bonds, which pay 4% and 5% simple interest. The annual interest is \$690. Find the amount invested at each rate.
60. **Tee Shirt Sales.** Mack's Tee Shirt Shack sold 36 shirts one day. All short-sleeved tee shirts cost \$12 each and all long-sleeved tee shirts cost \$18 each. Total receipts for the day were \$522. How many of each kind of shirt were sold?
61. **Coffee Mixtures.** The owner of The Daily Grind coffee shop mixes French roast coffee worth \$9.00 per pound with Kenyan coffee worth \$7.50 per pound in order to get 10 lb of a mixture worth \$8.40 per pound. How much of each type of coffee was used?
62. **Commissions.** Jackson Manufacturing offers its sales representatives a choice between being paid a commission of 8% of sales or being paid a monthly salary of \$1500 plus a commission of 1% of sales. For what monthly sales do the two plans pay the same amount?
63. **Nutrition.** A one-cup serving of spaghetti with meatballs contains 260 Cal (calories) and 32 g of carbohydrates. A one-cup serving of chopped iceberg lettuce contains 5 Cal and 1 g of carbohydrates. (Source: *Home and Garden Bulletin No. 72*, U.S. Government Printing Office, Washington, D.C. 20402) How many servings of each would be required to obtain 400 Cal and 50 g of carbohydrates?
64. **Nutrition.** One serving of tomato soup contains 100 Cal and 18 g of carbohydrates. One slice of whole wheat bread contains 70 Cal and 13 g of carbohydrates. (Source: *Home and Garden Bulletin No. 72*, U.S. Government Printing Office, Washington, D.C. 20402) How many servings of

each would be required to obtain 230 Cal and 42 g of carbohydrates?

65. **Motion.** A Leisure Time Cruises riverboat travels 46 km downstream in 2 hr. It travels 51 km upstream in 3 hr. Find the speed of the boat and the speed of the stream.
66. **Motion.** A DC10 airplane travels 3000 km with a tailwind in 3 hr. It travels 3000 km with a headwind in 4 hr. Find the speed of the plane and the speed of the wind.
67. **Motion.** Two private airplanes travel toward each other from cities that are 780 km apart at speeds of 190 km/h and 200 km/h. They left at the same time. In how many hours will they meet?
68. **Motion.** Christopher's boat travels 45 mi downstream in 3 hr. The return trip upstream takes 5 hr. Find the speed of the boat in still water and the speed of the current.
69. **Supply and Demand.** The supply and demand for a video-game system are related to price by the equations

$$y = 70 + 2x,$$

$$y = 175 - 5x,$$

respectively, where y is the price, in dollars, and x is the number of units, in thousands. Find the equilibrium point for this product.

70. **Supply and Demand.** The supply and demand for a particular model of treadmill are related to price by the equations

$$y = 240 + 40x,$$

$$y = 500 - 25x,$$

respectively, where y is the price, in dollars, and x is the number of units, in thousands. Find the equilibrium point for this product.



The point at which a company's costs equal its revenues is the **break-even point**. In Exercises 71–74, C represents the production cost, in dollars, of x units of a product and R represents the revenue, in dollars, from the sale of x units. Find the number of units that must be produced and sold in order to break even. That is, find the value of x for which $C = R$.

71. $C = 14x + 350,$ 72. $C = 8.5x + 75,$
 $R = 16.5x$ $R = 10x$
73. $C = 15x + 12,000,$ 74. $C = 3x + 400,$
 $R = 18x - 6000$ $R = 7x - 600$

Skill Maintenance

75. **Decline in Air Travel.** The number of people flying to, from, and within the United States in 2009 was at its lowest level since 2004. In 2009, the number of air travelers totaled 769.6 million, a decrease of 8.2% from 2004 (Source: Bureau of Transportation Statistics, Department of Transportation). Find the number of air travelers in 2004.
76. **Internet Retail Sales.** Online retail sales totaled \$133.6 billion in 2008. This was about three times the total in 2002. (Source: U.S. Census Bureau) Find the online sales total in 2002.

Consider the function

$$f(x) = x^2 - 4x + 3$$

in Exercises 77–80.

77. What are the inputs if the output is 15?
78. Given an output of 8, find the corresponding inputs.
79. What is the output if the input is -2 ?
80. Find the zeros of the function.

Synthesis

81. **Motion.** Nancy jogs and walks to campus each day. She averages 4 km/h walking and 8 km/h jogging. The distance from home to the campus is 6 km and she makes the trip in 1 hr. How far does she jog on each trip?
82. **e-Commerce.** Shirts.com advertises a limited-time sale, offering 1 turtleneck for \$15 and 2 turtlenecks for \$25. A total of 1250 turtlenecks are sold and \$16,750 is taken in. How many customers ordered 2 turtlenecks?

83. **Motion.** A train leaves Union Station for Central Station, 216 km away, at 9 A.M. One hour later, a train leaves Central Station for Union Station. They meet at noon. If the second train had started at 9 A.M. and the first train at 10:30 A.M., they would still have met at noon. Find the speed of each train.
84. **Antifreeze Mixtures.** An automobile radiator contains 16 L of antifreeze and water. This mixture is 30% antifreeze. How much of this mixture should be drained and replaced with pure antifreeze so that the final mixture will be 50% antifreeze?
85. Two solutions of the equation $Ax + By = 1$ are $(3, -1)$ and $(-4, -2)$. Find A and B .
86. **Ticket Line.** You are in line at a ticket window. There are 2 more people ahead of you in line than there are behind you. In the entire line, there are three times as many people as there are behind you. How many people are ahead of you?
87. **Gas Mileage.** The Honda Civic Hybrid vehicle, powered by gasoline–electric technology, gets 49 miles per gallon (mpg) in city driving and 51 mpg in highway driving (Source: Honda.com). The car is driven 447 mi on 9 gal of gasoline. How many miles were driven in the city and how many were driven on the highway?
88. **Motion.** Heather is standing on a railroad bridge, as shown in the figure below. A train is approaching from the direction shown by the yellow arrow. If Heather runs at a speed of 10 mph toward the train, she will reach point P on the bridge at the same moment that the train does. If she runs to point Q at the other end of the bridge at a speed of 10 mph, she will reach point Q also at the same moment that the train does. How fast, in miles per hour, is the train traveling?

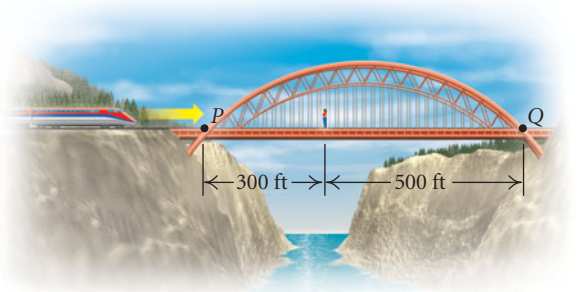

Systems of Equations in Three Variables

9.2

- ▶ Solve systems of linear equations in three variables.
- ▶ Use systems of three equations to solve applied problems.
- ▶ Model a situation using a quadratic function.

A **linear equation in three variables** is an equation equivalent to one of the form $Ax + By + Cz = D$, where A , B , C , and D are real numbers and none of A , B , and C is 0. A **solution of a system of three equations in three variables** is an ordered triple that makes all three equations true. For example, the triple $(2, -1, 0)$ is a solution of the system of equations

$$\begin{aligned}4x + 2y + 5z &= 6, \\2x - y + z &= 5, \\3x + 2y - z &= 4.\end{aligned}$$

We can verify this by substituting 2 for x , -1 for y , and 0 for z in each equation.

▶ Solving Systems of Equations in Three Variables

We will solve systems of equations in three variables using an algebraic method called **Gaussian elimination**, named for the German mathematician Karl Friedrich Gauss (1777–1855). Our goal is to transform the original system to an equivalent system (one with the same solution set) of the form

$$\begin{aligned}Ax + By + Cz &= D, \\Ey + Fz &= G, \\Hz &= K.\end{aligned}$$

Then we solve the third equation for z and back-substitute to find y and then x .

Each of the following operations can be used to transform the original system to an equivalent system in the desired form.

1. Interchange any two equations.
2. Multiply both sides of one of the equations by a nonzero constant.
3. Add a nonzero multiple of one equation to another equation.

EXAMPLE 1 Solve the following system:

$$x - 2y + 3z = 11, \quad (1)$$

$$4x + 2y - 3z = 4, \quad (2)$$

$$3x + 3y - z = 4. \quad (3)$$

Solution First, we choose one of the variables to eliminate using two different pairs of equations. Let's eliminate x from equations (2) and (3). We multiply equation (1) by -4 and add it to equation (2). We also multiply equation (1) by -3 and add it to equation (3).

$$\begin{array}{r} -4x + 8y - 12z = -44 \quad \text{Multiplying (1) by } -4 \\ \underline{4x + 2y - 3z = 4} \quad (2) \\ 10y - 15z = -40; \quad (4) \end{array}$$

$$\begin{array}{r} -3x + 6y - 9z = -33 \quad \text{Multiplying (1) by } -3 \\ \underline{3x + 3y - z = 4} \quad (3) \\ 9y - 10z = -29. \quad (5) \end{array}$$

Now we have

$$x - 2y + 3z = 11, \quad (1)$$

$$10y - 15z = -40, \quad (4)$$

$$9y - 10z = -29. \quad (5)$$

Next, we multiply equation (5) by 10 to make the y -coefficient a multiple of the y -coefficient in the equation above it:

$$x - 2y + 3z = 11, \quad (1)$$

$$10y - 15z = -40, \quad (4)$$

$$90y - 100z = -290. \quad (6)$$

Next, we multiply equation (4) by -9 and add it to equation (6):

$$-90y + 135z = 360 \quad \text{Multiplying (4) by } -9$$

$$\underline{90y - 100z = -290} \quad (6)$$

$$35z = 70. \quad (7)$$

We now have the system of equations

$$x - 2y + 3z = 11, \quad (1)$$

$$10y - 15z = -40, \quad (4)$$

$$35z = 70. \quad (7)$$

Now we solve equation (7) for z :

$$35z = 70$$

$$z = 2.$$

Then we back-substitute 2 for z in equation (4) and solve for y :

$$10y - 15 \cdot 2 = -40$$

$$10y - 30 = -40$$

$$10y = -10$$

$$y = -1.$$

Finally, we back-substitute -1 for y and 2 for z in equation (1) and solve for x :

$$x - 2(-1) + 3 \cdot 2 = 11$$

$$x + 2 + 6 = 11$$

$$x = 3.$$

We can check the triple $(3, -1, 2)$ in each of the three original equations. Since it makes all three equations true, the solution is $(3, -1, 2)$.

EXAMPLE 2 Solve the following system:

$$x + y + z = 7, \quad (1)$$

$$3x - 2y + z = 3, \quad (2)$$

$$x + 6y + 3z = 25. \quad (3)$$

Solution We multiply equation (1) by -3 and add it to equation (2). We also multiply equation (1) by -1 and add it to equation (3).

$$x + y + z = 7, \quad (1)$$

$$-5y - 2z = -18, \quad (4)$$

$$5y + 2z = 18 \quad (5)$$

Next, we add equation (4) to equation (5):

$$x + y + z = 7, \quad (1)$$

$$-5y - 2z = -18, \quad (4)$$

$$0 = 0.$$

The equation $0 = 0$ tells us that equations (1), (2), and (3) are dependent. This means that the original system of three equations is equivalent to a system of two equations. One way to see this is to observe that four times equation (1) minus equation (2) is equation (3). Thus removing equation (3) from the system does not affect the solution of the system. We can say that the original system is equivalent to

$$x + y + z = 7, \quad (1)$$

$$3x - 2y + z = 3. \quad (2)$$

In this particular case, the original system has infinitely many solutions. (In some cases, a system containing dependent equations is inconsistent.) To find an expression for these solutions, we first solve equation (4) for either y or z . We choose to solve for y :

$$-5y - 2z = -18 \quad (4)$$

$$-5y = 2z - 18$$

$$y = -\frac{2}{5}z + \frac{18}{5}.$$

Then we back-substitute in equation (1) to find an expression for x in terms of z :

$$x - \frac{2}{5}z + \frac{18}{5} + z = 7 \quad \text{Substituting } -\frac{2}{5}z + \frac{18}{5} \text{ for } y$$

$$x + \frac{3}{5}z + \frac{18}{5} = 7$$

$$x + \frac{3}{5}z = \frac{17}{5}$$

$$x = -\frac{3}{5}z + \frac{17}{5}.$$

The solutions of the system of equations are ordered triples of the form $(-\frac{3}{5}z + \frac{17}{5}, -\frac{2}{5}z + \frac{18}{5}, z)$, where z can be any real number. Any real number that we use for z then gives us values for x and y and thus an ordered triple in the solution set. For example, if we choose $z = 0$, we have the solution $(\frac{17}{5}, \frac{18}{5}, 0)$. If we choose $z = -1$, we have $(4, 4, -1)$.

 **Now Try Exercise 9.**

If we get a false equation, such as $0 = -5$, at some stage of the elimination process, we conclude that the original system is *inconsistent*; that is, it has no solutions.

Although systems of three linear equations in three variables do not lend themselves well to graphical solutions, it is of interest to picture some possible solutions. The graph of a linear equation in three variables is a plane. Thus the solution set of such a system is the intersection of three planes. Some possibilities are shown below.

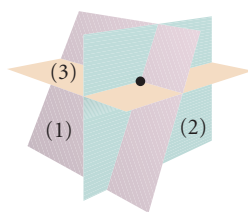

One solution: planes intersect in exactly one point.

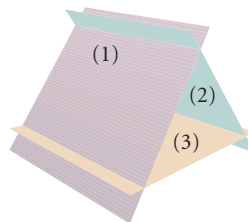

No solution: three planes; each intersects another; at no point do all intersect.

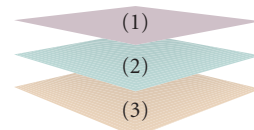

No solution: parallel planes.

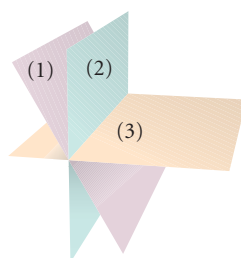

Infinitely many solutions: planes intersect in a line.

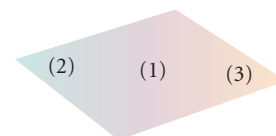

Infinitely many solutions: planes are identical.

► Applications

Systems of equations in three or more variables allow us to solve many problems in fields such as business, the social and natural sciences, and engineering.

EXAMPLE 3 Investment. Luis inherited \$15,000 and invested part of it in a money market account, part in municipal bonds, and part in a mutual fund. After 1 yr, he received a total of \$730 in simple interest from the three investments. The money market account paid 4% annually, the bonds paid 5% annually, and the mutual fund paid 6% annually. There was \$2000 more invested in the mutual fund than in bonds. Find the amount that Luis invested in each category.

Solution

- Familiarize.** We let x , y , and z represent the amounts invested in the money market account, the bonds, and the mutual fund, respectively. Then the amounts of income produced annually by each investment are given by $4\%x$, $5\%y$, and $6\%z$, or $0.04x$, $0.05y$, and $0.06z$.
- Translate.** The fact that a total of \$15,000 is invested gives us one equation:

$$x + y + z = 15,000.$$

Since the total interest is \$730, we have a second equation:

$$0.04x + 0.05y + 0.06z = 730.$$

Another statement in the problem gives us a third equation.

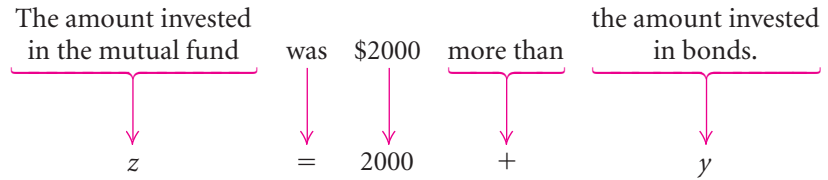

We now have a system of three equations:

$$\begin{aligned} x + y + z &= 15,000, & x + y + z &= 15,000, \\ 0.04x + 0.05y + 0.06z &= 730, & \text{or } 4x + 5y + 6z &= 73,000, \\ z &= 2000 + y; & -y + z &= 2000. \end{aligned}$$

- 3. Carry out.** Solving the system of equations, we get (7000, 3000, 5000).
- 4. Check.** The sum of the numbers is 15,000. The income produced is $0.04(7000) + 0.05(3000) + 0.06(5000) = 280 + 150 + 300$, or \$730. Also the amount invested in the mutual fund, \$5000, is \$2000 more than the amount invested in bonds, \$3000. Our solution checks in the original problem.
- 5. State.** Luis invested \$7000 in a money market account, \$3000 in municipal bonds, and \$5000 in a mutual fund. ➔ Now Try Exercise 29.

► Mathematical Models and Applications

Recall that when we model a situation using a linear function $f(x) = mx + b$, we need to know two data points in order to determine m and b . For a quadratic model, $f(x) = ax^2 + bx + c$, we need three data points in order to determine a , b , and c .

EXAMPLE 4 Snow-Sports Sales. The table below lists sales of winter sports equipment, apparel, and accessories in November in three recent years. Use the data to find a quadratic function that gives the snow-sports sales as a function of the number of years after 2006. Then use the function to estimate snow-sports sales in 2009.

YEAR, x	SNOW-SPORTS SALES (in millions)
2006, 0	\$296
2007, 1	423
2008, 2	402



Source: SIA Retail Audit

TECHNOLOGY CONNECTION

The function in Example 4 can also be found using the QUADRATIC REGRESSION feature on a graphing calculator. Note that the method of Example 4 works when we have exactly three data points, whereas the QUADRATIC REGRESSION feature on a graphing calculator can be used for *three or more* points.

```
QuadReg
y=ax^2+bx+c
a=-74
b=201
c=296
R^2=1
```

```
Y1(3)                233
```

Solution We let $x =$ the number of years after 2006 and $s(x) =$ snow-sports sales. Then $x = 0$ corresponds to 2006, $x = 1$ corresponds to 2007, and $x = 2$ corresponds to 2008. We use the three data points $(0, 296)$, $(1, 423)$, and $(2, 402)$ to find a , b , and c in the function $f(x) = ax^2 + bx + c$.

First, we substitute:

$$f(x) = ax^2 + bx + c$$

$$\text{For } (0, 296): 296 = a \cdot 0^2 + b \cdot 0 + c,$$

$$\text{For } (1, 423): 423 = a \cdot 1^2 + b \cdot 1 + c,$$

$$\text{For } (2, 402): 402 = a \cdot 2^2 + b \cdot 2 + c.$$

We now have a system of equations in the variables a , b , and c :

$$c = 296,$$

$$a + b + c = 423,$$

$$4a + 2b + c = 402.$$

Solving this system, we get $(-74, 201, 296)$.

Thus,

$$f(x) = -74x^2 + 201x + 296.$$

To estimate snow-sports sales in 2009, we find $f(3)$, since 2009 is 3 yr after 2006:

$$\begin{aligned} f(3) &= -74 \cdot 3^2 + 201 \cdot 3 + 296 \\ &= \$233 \text{ million.} \end{aligned}$$

 **Now Try Exercise 33.**

9.2

Exercise Set

Solve the system of equations.

$$\begin{aligned} 1. \quad &x + y + z = 2, \\ &6x - 4y + 5z = 31, \\ &5x + 2y + 2z = 13 \end{aligned}$$

$$\begin{aligned} 3. \quad &x - y + 2z = -3, \\ &x + 2y + 3z = 4, \\ &2x + y + z = -3 \end{aligned}$$

$$\begin{aligned} 5. \quad &x + 2y - z = 5, \\ &2x - 4y + z = 0, \\ &3x + 2y + 2z = 3 \end{aligned}$$

$$\begin{aligned} 7. \quad &x + 2y - z = -8, \\ &2x - y + z = 4, \\ &8x + y + z = 2 \end{aligned}$$

$$\begin{aligned} 9. \quad &2x + y - 3z = 1, \\ &x - 4y + z = 6, \\ &4x - 7y - z = 13 \end{aligned}$$

$$\begin{aligned} 2. \quad &x + 6y + 3z = 4, \\ &2x + y + 2z = 3, \\ &3x - 2y + z = 0 \end{aligned}$$

$$\begin{aligned} 4. \quad &x + y + z = 6, \\ &2x - y - z = -3, \\ &x - 2y + 3z = 6 \end{aligned}$$

$$\begin{aligned} 6. \quad &2x + 3y - z = 1, \\ &x + 2y + 5z = 4, \\ &3x - y - 8z = -7 \end{aligned}$$

$$\begin{aligned} 8. \quad &x + 2y - z = 4, \\ &4x - 3y + z = 8, \\ &5x - y = 12 \end{aligned}$$

$$\begin{aligned} 10. \quad &x + 3y + 4z = 1, \\ &3x + 4y + 5z = 3, \\ &x + 8y + 11z = 2 \end{aligned}$$

$$\begin{aligned} 11. \quad &4a + 9b = 8, \\ &8a + 6c = -1, \\ &6b + 6c = -1 \end{aligned}$$

$$\begin{aligned} 13. \quad &2x + z = 1, \\ &3y - 2z = 6, \\ &x - 2y = -9 \end{aligned}$$

$$\begin{aligned} 15. \quad &w + x + y + z = 2, \\ &w + 2x + 2y + 4z = 1, \\ &-w + x - y - z = -6, \\ &-w + 3x + y - z = -2 \end{aligned}$$

$$\begin{aligned} 16. \quad &w + x - y + z = 0, \\ &-w + 2x + 2y + z = 5, \\ &-w + 3x + y - z = -4, \\ &-2w + x + y - 3z = -7 \end{aligned}$$

17. **Winter Olympic Sites.** The Winter Olympics have been held a total of 21 times on the continents of North America, Europe, and Asia. The number of

$$\begin{aligned} 12. \quad &3p + 2r = 11, \\ &q - 7r = 4, \\ &p - 6q = 1 \end{aligned}$$

$$\begin{aligned} 14. \quad &3x + 4z = -11, \\ &x - 2y = 5, \\ &4y - z = -10 \end{aligned}$$

European sites is 5 more than the total number of sites in North America and Asia. There are 4 more sites in North America than in Asia. (Source: USA Today research) Find the number of Winter Olympic sites on each continent.



18. **Top Apple Growers.** The top three apple growers in the world—China, the United States, and Turkey—grew a total of about 74 billion lb of apples in a recent year. China produced 44 billion lb more than the combined production of the United States and Turkey. The United States produced twice as many pounds of apples as Turkey. (Source: U.S. Apple Association) Find the number of pounds of apples produced by each country.
19. **Restaurant Meals.** The total number of restaurant-purchased meals that the average person will eat in a restaurant, in a car, or at home in a year is 170. The total number of these meals eaten in a car or at home exceeds the number eaten in a restaurant by 14. Twenty more restaurant-purchased meals will be eaten in a restaurant than at home. (Source: The NPD Group) Find the number of restaurant-purchased meals eaten in a restaurant, the number eaten in a car, and the number eaten at home.



20. **Adopting Abroad.** The three foreign countries from which the largest number of children were adopted in 2009 were China, Ethiopia, and Russia. A total of 6864 children were adopted from these countries. The number of children adopted from China was 862 fewer than the total number adopted from Ethiopia and Russia. Twice the number adopted from Russia is 171 more than the number adopted from China. (Source: U.S. Department of State) Find the number of children adopted from each country.
21. **Jolts of Caffeine.** One 8-oz serving each of brewed coffee, Red Bull energy drink, and Mountain Dew soda contains 197 mg of caffeine. One serving of brewed coffee has 6 mg more caffeine than two servings of Mountain Dew. One serving of Red Bull contains 37 mg less caffeine than one serving each of brewed coffee and Mountain Dew. (Source: Australian Institute of Sport) Find the amount of caffeine in one serving of each beverage.
22. **Mother's Day Spending.** The top three Mother's Day gifts are flowers, jewelry, and gift certificates. The total of the average amounts spent on these gifts is \$53.42. The average amount spent on jewelry is \$4.40 more than the average amount spent on gift certificates. Together, the average amounts spent on flowers and gift certificates is \$15.58 more than the average amount spent on jewelry. (Source: BIGresearch) What is the average amount spent on each type of gift?
23. **Favorite Pets.** Americans own a total of about 355 million fish, cats, and dogs as pets. The number of fish owned is 11 million more than the total number of cats and dogs owned, and 16 million more cats are owned than dogs. (Source: American Pet Products Manufacturers Association) How many of each type of pet do Americans own?
24. **Mail-Order Business.** Natural Fibers Clothing charges \$4 for shipping orders of \$25 or less, \$8 for orders from \$25.01 to \$75, and \$10 for orders over \$75. One week shipping charges for 600 orders totaled \$4280. Eighty more orders for \$25 or less were shipped than orders for more than \$75. Find the number of orders shipped at each rate.

25. **Biggest Weekend at the Box Office.** At the time of this writing, the movies *The Dark Knight*, *Spider-Man 3*, and *The Twilight Saga: New Moon* hold the record for having the three highest-grossing weekends at the box office, with a total of \$452 million. Together, *Spider-Man 3* and *New Moon* earned \$136 million more than *The Dark Knight*. *New Moon* earned \$15 million less than *The Dark Knight*. (Source: the-numbers.com) Find the amount earned by each movie.
26. **Spring Cleaning.** In a group of 100 adults, 70 say they are most likely to do spring housecleaning in March, April, or May. Of these 70, the number who clean in April is 14 more than the total number who clean in March and May. The total number who clean in April and May is 2 more than three times the number who clean in March. (Source: Zoomerang online survey) Find the number who clean in each month.



27. **Nutrition.** A hospital dietician must plan a lunch menu that provides 485 Cal, 41.5 g of carbohydrates, and 35 mg of calcium. A 3-oz serving of broiled ground beef contains 245 Cal, 0 g of carbohydrates, and 9 mg of calcium. One baked potato contains 145 Cal, 34 g of carbohydrates, and 8 mg of calcium. A one-cup serving of strawberries contains 45 Cal, 10 g of carbohydrates, and 21 mg of calcium. (Source: *Home and Garden Bulletin No. 72*, U.S. Government Printing Office, Washington, D.C. 20402) How many servings of each are required to provide the desired nutritional values?

28. **Nutrition.** A diabetic patient wishes to prepare a meal consisting of roasted chicken breast, mashed potatoes, and peas. A 3-oz serving of roasted skinless chicken breast contains 140 Cal, 27 g of protein, and 64 mg of sodium. A one-cup serving of mashed potatoes contains 160 Cal, 4 g of protein, and 636 mg of sodium, and a one-cup serving of peas contains 125 Cal, 8 g of protein, and 139 mg of sodium. (Source: *Home and Garden Bulletin No. 72*, U.S. Government Printing Office, Washington, D.C. 20402) How many servings of each should be used if the meal is to contain 415 Cal, 50.5 g of protein, and 553 mg of sodium?



29. **Investment.** Jamal earns a year-end bonus of \$5000 and puts it in 3 one-year investments that pay \$243 in simple interest. Part is invested at 3%, part at 4%, and part at 6%. There is \$1500 more invested at 6% than at 3%. Find the amount invested at each rate.
30. **Investment.** Casey receives \$126 per year in simple interest from three investments. Part is invested at 2%, part at 3%, and part at 4%. There is \$500 more invested at 3% than at 2%. The amount invested at 4% is three times the amount invested at 3%. Find the amount invested at each rate.
31. **Price Increases.** Orange juice, a raisin bagel, and a cup of coffee from Kelly's Koffee Kart cost a total of \$5.35. Kelly posts a notice announcing that, effective the following week, the price of orange juice will increase 25% and the price of bagels will increase 20%. After the increase, the same purchase will cost a total of \$6.20, and orange juice will cost 50¢ more than coffee. Find the price of each item before the increase.

32. **Cost of Snack Food.** Martin and Eva pool their loose change to buy snacks on their coffee break. One day, they spent \$6.75 on 1 carton of milk, 2 donuts, and 1 cup of coffee. The next day, they spent \$8.50 on 3 donuts and 2 cups of coffee. The third day, they bought 1 carton of milk, 1 donut, and 2 cups of coffee and spent \$7.25. On the fourth day, they have a total of \$6.45 left. Is this enough to buy 2 cartons of milk and 2 donuts?

33. **Job Loss.** The table below lists the percent of American workers who responded that they were likely to be laid off from their jobs in the coming year, represented in terms of the number of years after 1990.

Year, x	Percent Who Say Lay-off Likely
1990, 0	16
1997, 7	9
2010, 20	21

Source: Gallup Poll

- Fit a quadratic function $f(x) = ax^2 + bx + c$ to the data.
- Use the function to estimate the percent of workers who responded that they were likely to be laid off in the coming year in 2003.

34. **Student Loans.** The table below lists the volume of nonfederal student loans, in billions of dollars, represented in terms of the number of years after 2004.

Year, x	Volume of Student Loans (in billions)
2004, 0	\$15.1
2006, 2	20.5
2008, 4	11.0

Source: Trends in Student Aid

- Fit a quadratic function $f(x) = ax^2 + bx + c$ to the data.
- Use the function to estimate the volume of non-federal student loans in 2007.

35. **Farm Acreage.** The table below lists the average size of U.S. farms, represented in terms of the number of years since 1997.

Year, x	Average Size of U.S. Farms (in number of acres)
1997, 0	431
2002, 5	441
2007, 10	418

Source: 2007 Census of Agriculture

- Fit a quadratic function $f(x) = ax^2 + bx + c$ to the data.
- Use the function to estimate the average size of U.S. farms in 2009.

36. **Book Shipments.** The table below lists the number of books shipped by publishers, in billions, represented in terms of the number of years after 2007.

Year, x	Books Shipped (in billions)
2007, 0	3.127
2008, 1	3.079
2009, 2	3.101

Source: Book Industry Study Group, Inc.

- Fit a quadratic function $f(x) = ax^2 + bx + c$ to the data.
- Use the function to estimate the number of books shipped in 2012.

Skill Maintenance

In each of Exercises 37–44, fill in the blank with the correct term. Some of the given choices will not be used.

Descartes' rule of signs
 the leading-term test
 the intermediate value theorem
 the fundamental theorem of algebra
 a polynomial function
 a rational function
 a one-to-one function
 a constant function
 a horizontal asymptote
 a vertical asymptote
 an oblique asymptote
 direct variation
 inverse variation
 a horizontal line
 a vertical line
 parallel
 perpendicular

37. Two lines with slopes m_1 and m_2 are _____ if and only if the product of their slopes is -1 .
38. We can use _____ to determine the behavior of the graph of a polynomial function as $x \rightarrow \infty$ or as $x \rightarrow -\infty$.
39. If it is possible for _____ to cross a graph more than once, then the graph is not the graph of a function.
40. A function is _____ if different inputs have different outputs.
41. _____ is a function that is a quotient of two polynomials.
42. If a situation gives rise to a function $f(x) = k/x$, or $y = k/x$, where k is a positive constant, we say that we have _____.
43. _____ of a rational function $p(x)/q(x)$, where $p(x)$ and $q(x)$ have no common factors other than constants, occurs at an x -value that makes the denominator 0.
44. When the numerator and the denominator of a rational function have the same degree, the graph of the function has _____.

Synthesis

In Exercises 45 and 46, let u represent $1/x$, v represent $1/y$, and w represent $1/z$. Solve first for u , v , and w . Then solve the system of equations.

$$45. \begin{cases} \frac{2}{x} - \frac{1}{y} - \frac{3}{z} = -1, \\ \frac{2}{x} - \frac{1}{y} + \frac{1}{z} = -9, \\ \frac{1}{x} + \frac{2}{y} - \frac{4}{z} = 17 \end{cases} \quad 46. \begin{cases} \frac{2}{x} + \frac{2}{y} - \frac{3}{z} = 3, \\ \frac{1}{x} - \frac{2}{y} - \frac{3}{z} = 9, \\ \frac{7}{x} - \frac{2}{y} + \frac{9}{z} = -39 \end{cases}$$

47. Find the sum of the angle measures at the tips of the star.

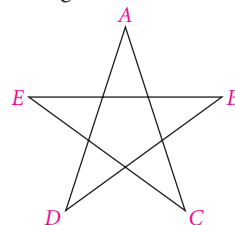

48. **Transcontinental Railroad.** Use the following facts to find the year in which the first U.S. transcontinental railroad was completed. The sum of the digits in the year is 24. The units digit is 1 more than the hundreds digit. Both the tens and the units digits are multiples of three.

In Exercises 49 and 50, three solutions of an equation are given. Use a system of three equations in three variables to find the constants and write the equation.

49. $Ax + By + Cz = 12$;
 $(1, \frac{3}{4}, 3)$, $(\frac{4}{3}, 1, 2)$, and $(2, 1, 1)$

50. $y = B - Mx - Nz$;
 $(1, 1, 2)$, $(3, 2, -6)$, and $(\frac{3}{2}, 1, 1)$

In Exercises 51 and 52, four solutions of the equation $y = ax^3 + bx^2 + cx + d$ are given. Use a system of four equations in four variables to find the constants a , b , c , and d and write the equation.

51. $(-2, 59)$, $(-1, 13)$, $(1, -1)$, and $(2, -17)$

52. $(-2, -39)$, $(-1, -12)$, $(1, -6)$, and $(3, 16)$

53. **Theater Attendance.** A performance at the Bingham Performing Arts Center was attended by 100 people. The audience consisted of adults, students, and children. The ticket prices were \$10 each for adults, \$3 each for students, and 50 cents each for children. The total amount of money taken in was \$100. How many adults, students, and children were in attendance? Does there seem to be some information missing? Do some careful reasoning.

Matrices and Systems of Equations

9.3

► Solve systems of equations using matrices.

► Matrices and Row-Equivalent Operations

In this section, we consider additional techniques for solving systems of equations. You have probably observed that when we solve a system of equations, we perform computations with the coefficients and the constants and continually rewrite the variables. We can streamline the solution process by omitting the variables until a solution is found. For example, the system

$$2x - 3y = 7,$$

$$x + 4y = -2$$

can be written more simply as

$$\left[\begin{array}{cc|c} 2 & -3 & 7 \\ 1 & 4 & -2 \end{array} \right].$$

The vertical line replaces the equals signs.

A rectangular array of numbers like the one above is called a **matrix** (pl., **matrices**). The matrix above is called an **augmented matrix** for the given system of equations, because it contains not only the coefficients but also the constant terms. The matrix

$$\begin{bmatrix} 2 & -3 \\ 1 & 4 \end{bmatrix}$$

is called the **coefficient matrix** of the system.

The **rows** of a matrix are horizontal, and the **columns** are vertical. The augmented matrix above has 2 rows and 3 columns, and the coefficient matrix has 2 rows and 2 columns. A matrix with m rows and n columns is said to be of **order** $m \times n$. Thus the order of the augmented matrix above is 2×3 , and the order of the coefficient matrix is 2×2 . When $m = n$, a matrix is said to be **square**. The coefficient matrix above is a square matrix. The numbers 2 and 4 lie on the **main diagonal** of the coefficient matrix. The numbers in a matrix are called **entries** or **elements**.

► Gaussian Elimination with Matrices

In Section 9.2, we described a series of operations that can be used to transform a system of equations to an equivalent system. Each of these operations corresponds to one that can be used to produce *row-equivalent matrices*.

Row-Equivalent Operations

1. Interchange any two rows.
2. Multiply each entry in a row by the same nonzero constant.
3. Add a nonzero multiple of one row to another row.

We can use these operations on the augmented matrix of a system of equations to solve the system.

EXAMPLE 1 Solve the following system:

$$2x - y + 4z = -3,$$

$$x - 2y - 10z = -6,$$

$$3x \quad + 4z = 7.$$

Solution First, we write the augmented matrix, writing 0 for the missing y -term in the last equation:

$$\left[\begin{array}{ccc|c} 2 & -1 & 4 & -3 \\ 1 & -2 & -10 & -6 \\ 3 & 0 & 4 & 7 \end{array} \right].$$

Our goal is to find a row-equivalent matrix of the form

$$\left[\begin{array}{ccc|c} 1 & a & b & c \\ 0 & 1 & d & e \\ 0 & 0 & 1 & f \end{array} \right].$$

The variables can then be reinserted to form equations from which we can complete the solution. This is done by working from the bottom equation to the top and using back-substitution.

The first step is to multiply and/or interchange rows so that each number in the first column below the first number is a multiple of that number. In this case, we interchange the first and second rows to obtain a 1 in the upper left-hand corner.

$$\left[\begin{array}{ccc|c} 1 & -2 & -10 & -6 \\ 2 & -1 & 4 & -3 \\ 3 & 0 & 4 & 7 \end{array} \right] \quad \begin{array}{l} \text{New row 1} = \text{row 2} \\ \text{New row 2} = \text{row 1} \end{array}$$

Next, we multiply the first row by -2 and add it to the second row. We also multiply the first row by -3 and add it to the third row.

$$\left[\begin{array}{ccc|c} 1 & -2 & -10 & -6 \\ 0 & 3 & 24 & 9 \\ 0 & 6 & 34 & 25 \end{array} \right] \quad \begin{array}{l} \text{Row 1 is unchanged.} \\ \text{New row 2} = -2(\text{row 1}) + \text{row 2} \\ \text{New row 3} = -3(\text{row 1}) + \text{row 3} \end{array}$$

TECHNOLOGY CONNECTION

Row-equivalent operations can be performed on a graphing calculator. For example, to interchange the first and second rows of the augmented matrix, as we did in the first step in Example 1, we enter the matrix as matrix **A** and select “rowSwap” from the MATRIX MATH menu. Some graphing calculators will not automatically store the matrix produced using a row-equivalent operation, so when several operations are to be performed in succession, it is helpful to store the result of each operation as it is produced. In the window below, we see both the matrix produced by the rowSwap operation and the indication that this matrix is stored as matrix **B**.

```
rowSwap([A],1,2)→[B]
[[1 -2 -10 -6]
 [2 -1 4 -3]
 [3 0 4 7 ]]
```

STUDY TIP

The online *Graphing Calculator Manual* that accompanies this text contains the keystrokes for performing all the row-equivalent operations in Example 1.

Now we multiply the second row by $\frac{1}{3}$ to get a 1 in the second row, second column.

$$\left[\begin{array}{ccc|c} 1 & -2 & -10 & -6 \\ 0 & 1 & 8 & 3 \\ 0 & 6 & 34 & 25 \end{array} \right] \quad \text{New row 2} = \frac{1}{3}(\text{row 2})$$

Then we multiply the second row by -6 and add it to the third row.

$$\left[\begin{array}{ccc|c} 1 & -2 & -10 & -6 \\ 0 & 1 & 8 & 3 \\ 0 & 0 & -14 & 7 \end{array} \right] \quad \text{New row 3} = -6(\text{row 2}) + \text{row 3}$$

Finally, we multiply the third row by $-\frac{1}{14}$ to get a 1 in the third row, third column.

$$\left[\begin{array}{ccc|c} 1 & -2 & -10 & -6 \\ 0 & 1 & 8 & 3 \\ 0 & 0 & 1 & -\frac{1}{2} \end{array} \right] \quad \text{New row 3} = -\frac{1}{14}(\text{row 3})$$

Now we can write the system of equations that corresponds to the last matrix above:

$$x - 2y - 10z = -6, \quad (1)$$

$$y + 8z = 3, \quad (2)$$

$$z = -\frac{1}{2}. \quad (3)$$

We back-substitute $-\frac{1}{2}$ for z in equation (2) and solve for y :

$$y + 8\left(-\frac{1}{2}\right) = 3$$

$$y - 4 = 3$$

$$y = 7.$$

Next, we back-substitute 7 for y and $-\frac{1}{2}$ for z in equation (1) and solve for x :

$$x - 2 \cdot 7 - 10\left(-\frac{1}{2}\right) = -6$$

$$x - 14 + 5 = -6$$

$$x - 9 = -6$$

$$x = 3.$$

The triple $\left(3, 7, -\frac{1}{2}\right)$ checks in the original system of equations, so it is the solution.

 Now Try Exercise 15.

The procedure followed in Example 1 is called **Gaussian elimination with matrices**. The last matrix in Example 1 is in **row-echelon form**. To be in this form, a matrix must have the following properties.

Row-Echelon Form

1. If a row does not consist entirely of 0's, then the first nonzero element in the row is a 1 (called a **leading 1**).
2. For any two successive nonzero rows, the leading 1 in the lower row is farther to the right than the leading 1 in the higher row.
3. All the rows consisting entirely of 0's are at the bottom of the matrix.

If a fourth property is also satisfied, a matrix is said to be in **reduced row-echelon form**:

4. Each column that contains a leading 1 has 0's everywhere else.

EXAMPLE 2 Which of the following matrices are in row-echelon form? Which, if any, are in reduced row-echelon form?

$$\text{a) } \left[\begin{array}{ccc|c} 1 & -3 & 5 & -2 \\ 0 & 1 & -4 & 3 \\ 0 & 0 & 1 & 10 \end{array} \right]$$

$$\text{b) } \left[\begin{array}{cc|c} 0 & -1 & 2 \\ 0 & 1 & 5 \end{array} \right]$$

$$\text{c) } \left[\begin{array}{cccc|c} 1 & -2 & -6 & 4 & 7 \\ 0 & 3 & 5 & -8 & -1 \\ 0 & 0 & 1 & 9 & 2 \end{array} \right]$$

$$\text{d) } \left[\begin{array}{ccc|c} 1 & 0 & 0 & -2.4 \\ 0 & 1 & 0 & 0.8 \\ 0 & 0 & 1 & 5.6 \end{array} \right]$$

$$\text{e) } \left[\begin{array}{cccc|c} 1 & 0 & 0 & 0 & \frac{2}{3} \\ 0 & 1 & 0 & 0 & -\frac{1}{4} \\ 0 & 0 & 1 & 0 & \frac{6}{7} \\ 0 & 0 & 0 & 0 & 0 \end{array} \right]$$

$$\text{f) } \left[\begin{array}{ccc|c} 1 & -4 & 2 & 5 \\ 0 & 0 & 0 & 0 \\ 0 & 1 & -3 & -8 \end{array} \right]$$

Solution The matrices in (a), (d), and (e) satisfy the row-echelon criteria and, thus, are in row-echelon form. In (b) and (c), the first nonzero elements of the first and second rows, respectively, are not 1. In (f), the row consisting entirely of 0's is not at the bottom of the matrix. Thus the matrices in (b), (c), and (f) are not in row-echelon form. In (d) and (e), not only are the row-echelon criteria met but each column that contains a leading 1 also has 0's elsewhere, so these matrices are in reduced row-echelon form. 

► Gauss–Jordan Elimination

We have seen that with Gaussian elimination we perform row-equivalent operations on a matrix to obtain a row-equivalent matrix in row-echelon form. When we continue to apply these operations until we have a matrix in *reduced* row-echelon form, we are using **Gauss–Jordan elimination**. This method is named for Karl Friedrich Gauss and Wilhelm Jordan (1842–1899).

EXAMPLE 3 Use Gauss–Jordan elimination to solve the system of equations in Example 1.

Solution Using Gaussian elimination in Example 1, we obtained the matrix

$$\left[\begin{array}{ccc|c} 1 & -2 & -10 & -6 \\ 0 & 1 & 8 & 3 \\ 0 & 0 & 1 & -\frac{1}{2} \end{array} \right].$$

We continue to perform row-equivalent operations until we have a matrix in reduced row-echelon form. We multiply the third row by 10 and add it to the first row. We also multiply the third row by -8 and add it to the second row.

$$\left[\begin{array}{ccc|c} 1 & -2 & 0 & -11 \\ 0 & 1 & 0 & 7 \\ 0 & 0 & 1 & -\frac{1}{2} \end{array} \right] \quad \begin{array}{l} \text{New row 1} = 10(\text{row 3}) + \text{row 1} \\ \text{New row 2} = -8(\text{row 3}) + \text{row 2} \end{array}$$

Next, we multiply the second row by 2 and add it to the first row.

$$\left[\begin{array}{ccc|c} 1 & 0 & 0 & 3 \\ 0 & 1 & 0 & 7 \\ 0 & 0 & 1 & -\frac{1}{2} \end{array} \right] \quad \text{New row 1} = 2(\text{row 2}) + \text{row 1}$$

Writing the system of equations that corresponds to this matrix, we have

$$\begin{array}{rcl} x & = & 3, \\ y & = & 7, \\ z & = & -\frac{1}{2}. \end{array}$$

We can actually read the solution, $(3, 7, -\frac{1}{2})$, directly from the last column of the reduced row-echelon matrix.

 **Now Try Exercise 27.**

TECHNOLOGY CONNECTION

After an augmented matrix is entered in a graphing calculator, reduced row-echelon form can be found directly using the “rref” operation from the MATRIX MATH menu.

```
rref([A]) ► Frac
[[ 1 0 0 3 ]
 [ 0 1 0 7 ]
 [ 0 0 1 -1/2 ]]
```

The application PolySmlt from the APPS menu can also be used to solve a system of equations.

EXAMPLE 4 Solve the following system:

$$\begin{array}{rcl} 3x - 4y - z & = & 6, \\ 2x - y + z & = & -1, \\ 4x - 7y - 3z & = & 13. \end{array}$$

Solution First, we write the augmented matrix and use Gauss–Jordan elimination.

$$\left[\begin{array}{ccc|c} 3 & -4 & -1 & 6 \\ 2 & -1 & 1 & -1 \\ 4 & -7 & -3 & 13 \end{array} \right]$$

We then multiply the second and third rows by 3 so that each number in the first column below the first number, 3, is a multiple of that number.

$$\left[\begin{array}{ccc|c} 3 & -4 & -1 & 6 \\ 6 & -3 & 3 & -3 \\ 12 & -21 & -9 & 39 \end{array} \right] \quad \begin{array}{l} \text{New row 2} = 3(\text{row 1}) \\ \text{New row 3} = 3(\text{row 1}) \end{array}$$

Next, we multiply the first row by -2 and add it to the second row. We also multiply the first row by -4 and add it to the third row.

$$\left[\begin{array}{ccc|c} 3 & -4 & -1 & 6 \\ 0 & 5 & 5 & -15 \\ 0 & -5 & -5 & 15 \end{array} \right] \quad \begin{array}{l} \text{New row 2} = -2(\text{row 1}) + \text{row 2} \\ \text{New row 3} = -4(\text{row 1}) + \text{row 3} \end{array}$$

Now we add the second row to the third row.

$$\left[\begin{array}{ccc|c} 3 & -4 & -1 & 6 \\ 0 & 5 & 5 & -15 \\ 0 & 0 & 0 & 0 \end{array} \right] \quad \text{New row 3} = \text{row 2} + \text{row 3}$$

We can stop at this stage because we have a row consisting entirely of 0's. The last row of the matrix corresponds to the equation $0 = 0$, which is true for all values of x , y , and z . Consequently, the equations are dependent and the system is equivalent to

$$\begin{aligned} 3x - 4y - z &= 6, \\ 5y + 5z &= -15. \end{aligned}$$

This particular system has infinitely many solutions. (A system containing dependent equations could be inconsistent.)

Solving the second equation for y gives us

$$y = -z - 3.$$

Substituting $-z - 3$ for y in the first equation and solving for x , we get

$$\begin{aligned} 3x - 4(-z - 3) - z &= 6 \\ 3x + 4z + 12 - z &= 6 \\ 3x + 3z + 12 &= 6 \\ 3x &= -3z - 6 \\ x &= -z - 2. \end{aligned}$$

Then the solutions of this system are of the form

$$(-z - 2, -z - 3, z),$$

where z can be any real number.



Similarly, if we obtain a row whose only nonzero entry occurs in the last column, we have an inconsistent system of equations. For example, in the matrix

$$\left[\begin{array}{ccc|c} 1 & 0 & 3 & -2 \\ 0 & 1 & 5 & 4 \\ 0 & 0 & 0 & 6 \end{array} \right],$$

the last row corresponds to the false equation $0 = 6$, so we know the original system of equations has no solution.

9.3 Exercise Set

Determine the order of the matrix.

1. $\begin{bmatrix} 1 & -6 \\ -3 & 2 \\ 0 & 5 \end{bmatrix}$

2. $\begin{bmatrix} 7 \\ -5 \\ -1 \\ 3 \end{bmatrix}$

3. $[2 \quad -4 \quad 0 \quad 9]$

4. $[-8]$

5. $\begin{bmatrix} 1 & -5 & -8 \\ 6 & 4 & -2 \\ -3 & 0 & 7 \end{bmatrix}$

6. $\begin{bmatrix} 13 & 2 & -6 & 4 \\ -1 & 18 & 5 & -12 \end{bmatrix}$

Write the augmented matrix for the system of equations.

7. $\begin{cases} 2x - y = 7, \\ x + 4y = -5 \end{cases}$

8. $\begin{cases} 3x + 2y = 8, \\ 2x - 3y = 15 \end{cases}$

9. $\begin{cases} x - 2y + 3z = 12, \\ 2x - 4z = 8, \\ 3y + z = 7 \end{cases}$

10. $\begin{cases} x + y - z = 7, \\ 3y + 2z = 1, \\ -2x - 5y = 6 \end{cases}$

Write the system of equations that corresponds to the augmented matrix.

11. $\left[\begin{array}{cc|c} 3 & -5 & 1 \\ 1 & 4 & -2 \end{array} \right]$

12. $\left[\begin{array}{cc|c} 1 & 2 & -6 \\ 4 & 1 & -3 \end{array} \right]$

13. $\left[\begin{array}{ccc|c} 2 & 1 & -4 & 12 \\ 3 & 0 & 5 & -1 \\ 1 & -1 & 1 & 2 \end{array} \right]$

14. $\left[\begin{array}{ccc|c} -1 & -2 & 3 & 6 \\ 0 & 4 & 1 & 2 \\ 2 & -1 & 0 & 9 \end{array} \right]$

Solve the system of equations using Gaussian elimination or Gauss–Jordan elimination.

15. $\begin{cases} 4x + 2y = 11, \\ 3x - y = 2 \end{cases}$

16. $\begin{cases} 2x + y = 1, \\ 3x + 2y = -2 \end{cases}$

17. $\begin{cases} 5x - 2y = -3, \\ 2x + 5y = -24 \end{cases}$

18. $\begin{cases} 2x + y = 1, \\ 3x - 6y = 4 \end{cases}$

19. $\begin{cases} 3x + 4y = 7, \\ -5x + 2y = 10 \end{cases}$

21. $\begin{cases} 3x + 2y = 6, \\ 2x - 3y = -9 \end{cases}$

23. $\begin{cases} x - 3y = 8, \\ -2x + 6y = 3 \end{cases}$

25. $\begin{cases} -2x + 6y = 4, \\ 3x - 9y = -6 \end{cases}$

27. $\begin{cases} x + 2y - 3z = 9, \\ 2x - y + 2z = -8, \\ 3x - y - 4z = 3 \end{cases}$

29. $\begin{cases} 4x - y - 3z = 1, \\ 8x + y - z = 5, \\ 2x + y + 2z = 5 \end{cases}$

31. $\begin{cases} x - 2y + 3z = -4, \\ 3x + y - z = 0, \\ 2x + 3y - 5z = 1 \end{cases}$

33. $\begin{cases} 2x - 4y - 3z = 3, \\ x + 3y + z = -1, \\ 5x + y - 2z = 2 \end{cases}$

35. $\begin{cases} p + q + r = 1, \\ p + 2q + 3r = 4, \\ 4p + 5q + 6r = 7 \end{cases}$

37. $\begin{cases} a + b - c = 7, \\ a - b + c = 5, \\ 3a + b - c = -1 \end{cases}$

39. $\begin{cases} -2w + 2x + 2y - 2z = -10, \\ w + x + y + z = -5, \\ 3w + x - y + 4z = -2, \\ w + 3x - 2y + 2z = -6 \end{cases}$

40. $\begin{cases} -w + 2x - 3y + z = -8, \\ -w + x + y - z = -4, \\ w + x + y + z = 22, \\ -w + x - y - z = -14 \end{cases}$

20. $\begin{cases} 5x - 3y = -2, \\ 4x + 2y = 5 \end{cases}$

22. $\begin{cases} x - 4y = 9, \\ 2x + 5y = 5 \end{cases}$

24. $\begin{cases} 4x - 8y = 12, \\ -x + 2y = -3 \end{cases}$

26. $\begin{cases} 6x + 2y = -10, \\ -3x - y = 6 \end{cases}$

28. $\begin{cases} x - y + 2z = 0, \\ x - 2y + 3z = -1, \\ 2x - 2y + z = -3 \end{cases}$

30. $\begin{cases} 3x + 2y + 2z = 3, \\ x + 2y - z = 5, \\ 2x - 4y + z = 0 \end{cases}$

32. $\begin{cases} 2x - 3y + 2z = 2, \\ x + 4y - z = 9, \\ -3x + y - 5z = 5 \end{cases}$

34. $\begin{cases} x + y - 3z = 4, \\ 4x + 5y + z = 1, \\ 2x + 3y + 7z = -7 \end{cases}$

36. $\begin{cases} m + n + t = 9, \\ m - n - t = -15, \\ 3m + n + t = 2 \end{cases}$

38. $\begin{cases} a - b + c = 3, \\ 2a + b - 3c = 5, \\ 4a + b - c = 11 \end{cases}$

Use Gaussian elimination or Gauss–Jordan elimination in Exercises 41–44.

41. **Borrowing.** Ishikawa Manufacturing borrowed \$30,000 to buy a new piece of equipment. Part of the money was borrowed at 8%, part at 10%, and part at 12%. The annual interest was \$3040, and the total amount borrowed at 8% and 10% was twice the

amount borrowed at 12%. How much was borrowed at each rate?

42. **Stamp Purchase.** Ricardo spent \$22.35 on 44¢ and 17¢ stamps. He bought a total of 60 stamps. How many of each type did he buy?



43. **Time of Return.** The Houlihans pay their babysitter \$5 per hour before 11 P.M. and \$7.50 per hour after 11 P.M. One evening they went out for 5 hr and paid the sitter \$30. What time did they come home?
44. **Advertising Expense.** eAuction.com spent a total of \$11 million on advertising in fiscal years 2010, 2011, and 2012. The amount spent in 2012 was three times the amount spent in 2010. The amount spent in 2011 was \$3 million less than the amount spent in 2012. How much was spent on advertising each year?

Skill Maintenance

In Exercises 45–52, classify the function as linear, quadratic, cubic, quartic, rational, exponential, or logarithmic.

45. $f(x) = 3^{x-1}$
46. $f(x) = 3x - 1$
47. $f(x) = \frac{3x - 1}{x^2 + 4}$
48. $f(x) = -\frac{3}{4}x^4 + \frac{9}{2}x^3 + 2x^2 - 4$
49. $f(x) = \ln(3x - 1)$
50. $f(x) = \frac{3}{4}x^3 - x$
51. $f(x) = 3$
52. $f(x) = 2 - x - x^2$

Synthesis

In Exercises 53 and 54, three solutions of the equation $y = ax^2 + bx + c$ are given. Use a system of three equations in three variables and Gaussian elimination or Gauss–Jordan elimination to find the constants a , b , and c and write the equation.

53. $(-3, 12)$, $(-1, -7)$, and $(1, -2)$
54. $(-1, 0)$, $(1, -3)$, and $(3, -22)$
55. Find two different row-echelon forms of

$$\begin{bmatrix} 1 & 5 \\ 3 & 2 \end{bmatrix}.$$

56. Consider the system of equations

$$x - y + 3z = -8,$$

$$2x + 3y - z = 5,$$

$$3x + 2y + 2kz = -3k.$$

For what value(s) of k , if any, will the system have:

- a) no solution?
 b) exactly one solution?
 c) infinitely many solutions?

Solve using matrices.

57. $y = x + z$,
 $3y + 5z = 4$,
 $x + 4 = y + 3z$
58. $x + y = 2z$,
 $2x - 5z = 4$,
 $x - z = y + 8$
59. $x - 4y + 2z = 7$,
 $3x + y + 3z = -5$
60. $x - y - 3z = 3$,
 $-x + 3y + z = -7$
61. $4x + 5y = 3$,
 $-2x + y = 9$,
 $3x - 2y = -15$
62. $2x - 3y = -1$,
 $-x + 2y = -2$,
 $3x - 5y = 1$

Matrix Operations

9.4

- ▶ Add, subtract, and multiply matrices when possible.
- ▶ Write a matrix equation equivalent to a system of equations.

In Section 9.3, we used matrices to solve systems of equations. Matrices are useful in many other types of applications as well. In this section, we study matrices and some of their properties.

A capital letter is generally used to name a matrix, and lower-case letters with double subscripts generally denote its entries. For example, a_{47} , read “ a sub four seven,” indicates the entry in the fourth row and the seventh column. A general term is represented by a_{ij} . The notation a_{ij} indicates the entry in row i and column j . In general, we can write a matrix as

$$\mathbf{A} = [a_{ij}] = \begin{bmatrix} a_{11} & a_{12} & a_{13} & \cdots & a_{1n} \\ a_{21} & a_{22} & a_{23} & \cdots & a_{2n} \\ a_{31} & a_{32} & a_{33} & \cdots & a_{3n} \\ \vdots & \vdots & \vdots & \cdots & \vdots \\ a_{m1} & a_{m2} & a_{m3} & \cdots & a_{mn} \end{bmatrix}$$

The matrix above has m rows and n columns; that is, its order is $m \times n$.

Two matrices are **equal** if they have the same order and corresponding entries are equal.

▶ Matrix Addition and Subtraction

To add or subtract matrices, we add or subtract their corresponding entries. The matrices must have the same order for this to be possible.

Addition and Subtraction of Matrices

Given two $m \times n$ matrices $\mathbf{A} = [a_{ij}]$ and $\mathbf{B} = [b_{ij}]$, their sum is

$$\mathbf{A} + \mathbf{B} = [a_{ij} + b_{ij}]$$

and their difference is

$$\mathbf{A} - \mathbf{B} = [a_{ij} - b_{ij}].$$

Addition of matrices is both commutative and associative.

TECHNOLOGY CONNECTION

We can use a graphing calculator to add matrices. In Example 1(a), we enter \mathbf{A} and \mathbf{B} and then find $\mathbf{A} + \mathbf{B}$.

$$\begin{array}{|l} \mathbf{[A]+[B]} \\ \hline \left[\begin{array}{cc} 1 & -3 \\ 6 & 3.5 \end{array} \right] \end{array}$$

We can do the same for the matrices in Example 1(b).

$$\begin{array}{|l} \mathbf{[A]+[B]} \\ \hline \left[\begin{array}{cc} 0 & 1 \\ 0 & 3 \\ 3 & 1 \end{array} \right] \end{array}$$

EXAMPLE 1 Find $\mathbf{A} + \mathbf{B}$ for each of the following.

$$\text{a) } \mathbf{A} = \begin{bmatrix} -5 & 0 \\ 4 & \frac{1}{2} \end{bmatrix}, \quad \mathbf{B} = \begin{bmatrix} 6 & -3 \\ 2 & 3 \end{bmatrix}$$

$$\text{b) } \mathbf{A} = \begin{bmatrix} 1 & 3 \\ -1 & 5 \\ 6 & 0 \end{bmatrix}, \quad \mathbf{B} = \begin{bmatrix} -1 & -2 \\ 1 & -2 \\ -3 & 1 \end{bmatrix}$$

Solution We have a pair of 2×2 matrices in part (a) and a pair of 3×2 matrices in part (b). Since each pair of matrices has the same order, we can add the corresponding entries.

$$\begin{aligned} \text{a) } \mathbf{A} + \mathbf{B} &= \begin{bmatrix} -5 & 0 \\ 4 & \frac{1}{2} \end{bmatrix} + \begin{bmatrix} 6 & -3 \\ 2 & 3 \end{bmatrix} \\ &= \begin{bmatrix} -5 + 6 & 0 + (-3) \\ 4 + 2 & \frac{1}{2} + 3 \end{bmatrix} = \begin{bmatrix} 1 & -3 \\ 6 & 3\frac{1}{2} \end{bmatrix} \end{aligned}$$

$$\begin{aligned} \text{b) } \mathbf{A} + \mathbf{B} &= \begin{bmatrix} 1 & 3 \\ -1 & 5 \\ 6 & 0 \end{bmatrix} + \begin{bmatrix} -1 & -2 \\ 1 & -2 \\ -3 & 1 \end{bmatrix} \\ &= \begin{bmatrix} 1 + (-1) & 3 + (-2) \\ -1 + 1 & 5 + (-2) \\ 6 + (-3) & 0 + 1 \end{bmatrix} = \begin{bmatrix} 0 & 1 \\ 0 & 3 \\ 3 & 1 \end{bmatrix} \end{aligned}$$

 **Now Try Exercise 5.**

EXAMPLE 2 Find $\mathbf{C} - \mathbf{D}$ for each of the following.

$$\text{a) } \mathbf{C} = \begin{bmatrix} 1 & 2 \\ -2 & 0 \\ -3 & -1 \end{bmatrix}, \quad \mathbf{D} = \begin{bmatrix} 1 & -1 \\ 1 & 3 \\ 2 & 3 \end{bmatrix}$$

$$\text{b) } \mathbf{C} = \begin{bmatrix} 5 & -6 \\ -3 & 4 \end{bmatrix}, \quad \mathbf{D} = \begin{bmatrix} -4 \\ 1 \end{bmatrix}$$

Solution

a) Since the order of each matrix is 3×2 , we can subtract corresponding entries:

$$\begin{aligned} \mathbf{C} - \mathbf{D} &= \begin{bmatrix} 1 & 2 \\ -2 & 0 \\ -3 & -1 \end{bmatrix} - \begin{bmatrix} 1 & -1 \\ 1 & 3 \\ 2 & 3 \end{bmatrix} \\ &= \begin{bmatrix} 1 - 1 & 2 - (-1) \\ -2 - 1 & 0 - 3 \\ -3 - 2 & -1 - 3 \end{bmatrix} = \begin{bmatrix} 0 & 3 \\ -3 & -3 \\ -5 & -4 \end{bmatrix}. \end{aligned}$$

TECHNOLOGY CONNECTION

We can use a graphing calculator to subtract matrices. In Example 2(a), we enter \mathbf{C} and \mathbf{D} and then find $\mathbf{C} - \mathbf{D}$.

$$\begin{array}{|l} \mathbf{[C]-[D]} \\ \hline \left[\begin{array}{cc} 0 & 3 \\ -3 & -3 \\ -5 & -4 \end{array} \right] \end{array}$$

- b) \mathbf{C} is a 2×2 matrix and \mathbf{D} is a 2×1 matrix. Since the matrices do not have the same order, we cannot subtract.  **Now Try Exercise 13.**

The **opposite**, or **additive inverse**, of a matrix is obtained by replacing each entry with its opposite.

EXAMPLE 3 Find $-\mathbf{A}$ and $\mathbf{A} + (-\mathbf{A})$ for

$$\mathbf{A} = \begin{bmatrix} 1 & 0 & 2 \\ 3 & -1 & 5 \end{bmatrix}.$$

Solution To find $-\mathbf{A}$, we replace each entry of \mathbf{A} with its opposite.

$$-\mathbf{A} = \begin{bmatrix} -1 & 0 & -2 \\ -3 & 1 & -5 \end{bmatrix},$$

$$\begin{aligned} \mathbf{A} + (-\mathbf{A}) &= \begin{bmatrix} 1 & 0 & 2 \\ 3 & -1 & 5 \end{bmatrix} + \begin{bmatrix} -1 & 0 & -2 \\ -3 & 1 & -5 \end{bmatrix} \\ &= \begin{bmatrix} 0 & 0 & 0 \\ 0 & 0 & 0 \end{bmatrix} \end{aligned}$$



A matrix having 0's for all its entries is called a **zero matrix**. When a zero matrix is added to a second matrix of the same order, the second matrix is unchanged. Thus a zero matrix is an **additive identity**. For example,

$$\begin{bmatrix} 2 & 3 & -4 \\ 0 & 6 & 5 \end{bmatrix} + \begin{bmatrix} 0 & 0 & 0 \\ 0 & 0 & 0 \end{bmatrix} = \begin{bmatrix} 2 & 3 & -4 \\ 0 & 6 & 5 \end{bmatrix}.$$

The matrix

$$\begin{bmatrix} 0 & 0 & 0 \\ 0 & 0 & 0 \end{bmatrix}$$

is the additive identity for any 2×3 matrix.

► Scalar Multiplication

When we find the product of a number and a matrix, we obtain a **scalar product**.

Scalar Product

The **scalar product** of a number k and a matrix \mathbf{A} is the matrix denoted $k\mathbf{A}$, obtained by multiplying each entry of \mathbf{A} by the number k . The number k is called a **scalar**.

TECHNOLOGY CONNECTION

Scalar products, like those in Example 4, can be found using a graphing calculator.

$3[A]$	$\begin{bmatrix} -9 & 0 \\ 12 & 15 \end{bmatrix}$
$(-1)[A]$	$\begin{bmatrix} 3 & 0 \\ -4 & -5 \end{bmatrix}$

EXAMPLE 4 Find $3A$ and $(-1)A$ for

$$A = \begin{bmatrix} -3 & 0 \\ 4 & 5 \end{bmatrix}.$$

Solution We have

$$3A = 3 \begin{bmatrix} -3 & 0 \\ 4 & 5 \end{bmatrix} = \begin{bmatrix} 3(-3) & 3 \cdot 0 \\ 3 \cdot 4 & 3 \cdot 5 \end{bmatrix} = \begin{bmatrix} -9 & 0 \\ 12 & 15 \end{bmatrix},$$

$$(-1)A = -1 \begin{bmatrix} -3 & 0 \\ 4 & 5 \end{bmatrix} = \begin{bmatrix} -1(-3) & -1 \cdot 0 \\ -1 \cdot 4 & -1 \cdot 5 \end{bmatrix} = \begin{bmatrix} 3 & 0 \\ -4 & -5 \end{bmatrix}.$$

 **Now Try Exercise 9.**

The properties of matrix addition and scalar multiplication are similar to the properties of addition and multiplication of real numbers.

Properties of Matrix Addition and Scalar Multiplication

For any $m \times n$ matrices A, B , and C and any scalars k and l :

$$A + B = B + A.$$

Commutative property of addition

$$A + (B + C) = (A + B) + C.$$

Associative property of addition

$$(kl)A = k(lA).$$

Associative property of scalar multiplication

$$k(A + B) = kA + kB.$$

Distributive property

$$(k + l)A = kA + lA.$$

Distributive property

There exists a unique matrix $\mathbf{0}$ such that:

$$A + \mathbf{0} = \mathbf{0} + A = A.$$

Additive identity property

There exists a unique matrix $-A$ such that:

$$A + (-A) = -A + A = \mathbf{0}.$$

Additive inverse property

EXAMPLE 5 Production. Waterworks, Inc., manufactures three types of kayaks in its two plants. The table below lists the number of each style produced at each plant in April.

	Whitewater Kayak	Ocean Kayak	Crossover Kayak
Madison Plant	150	120	100
Greensburg Plant	180	90	130

- Write a 2×3 matrix \mathbf{A} that represents the information in the table.
- The manufacturer increased production by 20% in May. Find a matrix \mathbf{M} that represents the increased production figures.
- Find the matrix $\mathbf{A} + \mathbf{M}$ and tell what it represents.

Solution

- a) Write the entries in the table in a 2×3 matrix \mathbf{A} .

$$\mathbf{A} = \begin{bmatrix} 150 & 120 & 100 \\ 180 & 90 & 130 \end{bmatrix}$$

- b) The production in May will be represented by $\mathbf{A} + 20\%\mathbf{A}$, or $\mathbf{A} + 0.2\mathbf{A}$, or $1.2\mathbf{A}$. Thus,

$$\mathbf{M} = (1.2) \begin{bmatrix} 150 & 120 & 100 \\ 180 & 90 & 130 \end{bmatrix} = \begin{bmatrix} 180 & 144 & 120 \\ 216 & 108 & 156 \end{bmatrix}.$$

$$\begin{aligned} \text{c) } \mathbf{A} + \mathbf{M} &= \begin{bmatrix} 150 & 120 & 100 \\ 180 & 90 & 130 \end{bmatrix} + \begin{bmatrix} 180 & 144 & 120 \\ 216 & 108 & 156 \end{bmatrix} \\ &= \begin{bmatrix} 330 & 264 & 220 \\ 396 & 198 & 286 \end{bmatrix} \end{aligned}$$

The matrix $\mathbf{A} + \mathbf{M}$ represents the total production of each of the three types of kayaks at each plant in April and in May.

 **Now Try Exercise 29.**

► Products of Matrices

Matrix multiplication is defined in such a way that it can be used in solving systems of equations and in many applications.

Matrix Multiplication

For an $m \times n$ matrix $\mathbf{A} = [a_{ij}]$ and an $n \times p$ matrix $\mathbf{B} = [b_{ij}]$, the **product** $\mathbf{AB} = [c_{ij}]$ is an $m \times p$ matrix, where

$$c_{ij} = a_{i1} \cdot b_{1j} + a_{i2} \cdot b_{2j} + a_{i3} \cdot b_{3j} + \cdots + a_{in} \cdot b_{nj}.$$

In other words, the entry c_{ij} in \mathbf{AB} is obtained by multiplying the entries in row i of \mathbf{A} by the corresponding entries in column j of \mathbf{B} and adding the results.

Note that we can multiply two matrices only when the number of columns in the first matrix is equal to the number of rows in the second matrix.

TECHNOLOGY CONNECTION

When the product AC in Example 6(d) is entered on a graphing calculator, an ERROR message is returned, indicating that the dimensions of the matrices are mismatched.

[A][C]

ERR: DIM MISMATCH

1 Quit
2: Goto

- d) The product AC is not defined because the number of columns of A , 3, is not equal to the number of rows of C , 2.

➔ Now Try Exercises 23 and 25.

EXAMPLE 7 Bakery Profit. Two of the items sold at Sweet Treats Bakery are gluten-free bagels and gluten-free doughnuts. The table below lists the number of dozens of each product that are sold at the bakery's three stores one week.

	Main Street Store	Avon Road Store	Dalton Avenue Store
Bagels (in dozens)	25	30	20
Doughnuts (in dozens)	40	35	15



The bakery's profit on one dozen bagels is \$5, and its profit on one dozen doughnuts is \$6. Use matrices to find the total profit on these items at each store for the given week.

Solution We can write the table showing the sales of the products as a 2×3 matrix:

$$S = \begin{bmatrix} 25 & 30 & 20 \\ 40 & 35 & 15 \end{bmatrix}.$$

The profit per dozen for each product can also be written as a matrix:

$$P = [5 \quad 6].$$

Then the total profit at each store is given by the matrix product PS :

$$\begin{aligned} PS &= [5 \quad 6] \begin{bmatrix} 25 & 30 & 20 \\ 40 & 35 & 15 \end{bmatrix} \\ &= [5 \cdot 25 + 6 \cdot 40 \quad 5 \cdot 30 + 6 \cdot 35 \quad 5 \cdot 20 + 6 \cdot 15] \\ &= [365 \quad 360 \quad 190]. \end{aligned}$$

The total profit on gluten-free bagels and gluten-free doughnuts for the given week was \$365 at the Main Street store, \$360 at the Avon Road store, and \$190 at the Dalton Avenue store.

➔ Now Try Exercise 33.

A matrix that consists of a single row, like \mathbf{P} in Example 7, is called a **row matrix**. Similarly, a matrix that consists of a single column, like

$$\begin{bmatrix} 8 \\ -3 \\ 5 \end{bmatrix},$$

is called a **column matrix**.

We have already seen that matrix multiplication is generally not commutative. Nevertheless, matrix multiplication does have some properties that are similar to those for multiplication of real numbers.

Properties of Matrix Multiplication

For matrices \mathbf{A} , \mathbf{B} , and \mathbf{C} , assuming that the indicated operations are possible:

$$\mathbf{A}(\mathbf{BC}) = (\mathbf{AB})\mathbf{C}. \quad \text{Associative property of multiplication}$$

$$\mathbf{A}(\mathbf{B} + \mathbf{C}) = \mathbf{AB} + \mathbf{AC}. \quad \text{Distributive property}$$

$$(\mathbf{B} + \mathbf{C})\mathbf{A} = \mathbf{BA} + \mathbf{CA}. \quad \text{Distributive property}$$

► Matrix Equations

We can write a matrix equation equivalent to a system of equations.

EXAMPLE 8 Write a matrix equation equivalent to the following system of equations:

$$4x + 2y - z = 3,$$

$$9x \quad \quad + z = 5,$$

$$4x + 5y - 2z = 1.$$

Solution We write the coefficients on the left in a matrix. We then write the product of that matrix and the column matrix containing the variables and set the result equal to the column matrix containing the constants on the right:

$$\begin{bmatrix} 4 & 2 & -1 \\ 9 & 0 & 1 \\ 4 & 5 & -2 \end{bmatrix} \begin{bmatrix} x \\ y \\ z \end{bmatrix} = \begin{bmatrix} 3 \\ 5 \\ 1 \end{bmatrix}.$$

If we let

$$\mathbf{A} = \begin{bmatrix} 4 & 2 & -1 \\ 9 & 0 & 1 \\ 4 & 5 & -2 \end{bmatrix}, \quad \mathbf{X} = \begin{bmatrix} x \\ y \\ z \end{bmatrix}, \quad \text{and} \quad \mathbf{B} = \begin{bmatrix} 3 \\ 5 \\ 1 \end{bmatrix},$$

we can write this matrix equation as $\mathbf{AX} = \mathbf{B}$.



In the next section, we will solve systems of equations using a matrix equation like the one in Example 8.

9.4 Exercise Set

Find x and y .

1. $[5 \ x] = [y \ -3]$

2. $\begin{bmatrix} 6x \\ 25 \end{bmatrix} = \begin{bmatrix} -9 \\ 5y \end{bmatrix}$

3. $\begin{bmatrix} 3 & 2x \\ y & -8 \end{bmatrix} = \begin{bmatrix} 3 & -2 \\ 1 & -8 \end{bmatrix}$

4. $\begin{bmatrix} x-1 & 4 \\ y+3 & -7 \end{bmatrix} = \begin{bmatrix} 0 & 4 \\ -2 & -7 \end{bmatrix}$

For Exercises 5–20, let

$$\mathbf{A} = \begin{bmatrix} 1 & 2 \\ 4 & 3 \end{bmatrix},$$

$$\mathbf{B} = \begin{bmatrix} -3 & 5 \\ 2 & -1 \end{bmatrix},$$

$$\mathbf{C} = \begin{bmatrix} 1 & -1 \\ -1 & 1 \end{bmatrix},$$

$$\mathbf{D} = \begin{bmatrix} 1 & 1 \\ 1 & 1 \end{bmatrix},$$

$$\mathbf{E} = \begin{bmatrix} 1 & 3 \\ 2 & 6 \end{bmatrix},$$

$$\mathbf{F} = \begin{bmatrix} 3 & 3 \\ -1 & -1 \end{bmatrix},$$

$$\mathbf{0} = \begin{bmatrix} 0 & 0 \\ 0 & 0 \end{bmatrix},$$

$$\mathbf{I} = \begin{bmatrix} 1 & 0 \\ 0 & 1 \end{bmatrix}.$$

Find each of the following.

5. $\mathbf{A} + \mathbf{B}$

6. $\mathbf{B} + \mathbf{A}$

7. $\mathbf{E} + \mathbf{0}$

8. $2\mathbf{A}$

9. $3\mathbf{F}$

10. $(-1)\mathbf{D}$

11. $3\mathbf{F} + 2\mathbf{A}$

12. $\mathbf{A} - \mathbf{B}$

13. $\mathbf{B} - \mathbf{A}$

14. \mathbf{AB}

15. \mathbf{BA}

16. $\mathbf{0F}$

17. \mathbf{CD}

18. \mathbf{EF}

19. \mathbf{AI}

20. \mathbf{IA}

Find the product, if possible.

21. $\begin{bmatrix} -1 & 0 & 7 \\ 3 & -5 & 2 \end{bmatrix} \begin{bmatrix} 6 \\ -4 \\ 1 \end{bmatrix}$

22. $[6 \ -1 \ 2] \begin{bmatrix} 1 & 4 \\ -2 & 0 \\ 5 & -3 \end{bmatrix}$

23. $\begin{bmatrix} -2 & 4 \\ 5 & 1 \\ -1 & -3 \end{bmatrix} \begin{bmatrix} 3 & -6 \\ -1 & 4 \end{bmatrix}$

24. $\begin{bmatrix} 2 & -1 & 0 \\ 0 & 5 & 4 \end{bmatrix} \begin{bmatrix} -3 & 1 & 0 \\ 0 & 2 & -1 \\ 5 & 0 & 4 \end{bmatrix}$

25. $\begin{bmatrix} 1 \\ -5 \\ 3 \end{bmatrix} \begin{bmatrix} -6 & 5 & 8 \\ 0 & 4 & -1 \end{bmatrix}$

26. $\begin{bmatrix} 2 & 0 & 0 \\ 0 & -1 & 0 \\ 0 & 0 & 3 \end{bmatrix} \begin{bmatrix} 0 & -4 & 3 \\ 2 & 1 & 0 \\ -1 & 0 & 6 \end{bmatrix}$

27. $\begin{bmatrix} 1 & -4 & 3 \\ 0 & 8 & 0 \\ -2 & -1 & 5 \end{bmatrix} \begin{bmatrix} 3 & 0 & 0 \\ 0 & -4 & 0 \\ 0 & 0 & 1 \end{bmatrix}$

28. $\begin{bmatrix} 4 \\ -5 \end{bmatrix} \begin{bmatrix} 2 & 0 \\ 6 & -7 \\ 0 & -3 \end{bmatrix}$

29. **Budget.** For the month of June, Nelia budgets \$300 for food, \$80 for clothes, and \$40 for entertainment.

- Write a 1×3 matrix \mathbf{B} that represents the amounts budgeted for these items.
- After receiving a raise, Nelia increases the amount budgeted for each item in July by 5%. Find a matrix \mathbf{R} that represents the new amounts.
- Find $\mathbf{B} + \mathbf{R}$ and tell what the entries represent.

30. **Produce.** The produce manager at Dugan's Market orders 40 lb of tomatoes, 20 lb of zucchini, and 30 lb of onions from a local farmer one week.

- Write a 1×3 matrix \mathbf{A} that represents the amount of each item ordered.
- The following week the produce manager increases her order by 10%. Find a matrix \mathbf{B} that represents this order.
- Find $\mathbf{A} + \mathbf{B}$ and tell what the entries represent.

31. **Nutrition.** A 3-oz serving of roasted, skinless chicken breast contains 140 Cal, 27 g of protein, 3 g of fat, 13 mg of calcium, and 64 mg of sodium. One-half cup of potato salad contains 180 Cal, 4 g of protein, 11 g of fat, 24 mg of calcium, and 662 mg of sodium. One broccoli spear contains 50 Cal, 5 g of protein, 1 g of fat, 82 mg of calcium, and 20 mg of sodium. (Source: *Home and Garden Bulletin No. 72*, U.S. Government Printing Office, Washington, D.C. 20402)

- Write 1×5 matrices **C**, **P**, and **B** that represent the nutritional values of each food.
- Find $\mathbf{C} + 2\mathbf{P} + 3\mathbf{B}$ and tell what the entries represent.

32. **Nutrition.** One slice of cheese pizza contains 290 Cal, 15 g of protein, 9 g of fat, and 39 g of carbohydrates. One-half cup of gelatin dessert contains 70 Cal, 2 g of protein, 0 g of fat, and 17 g of carbohydrates. One cup of whole milk contains 150 Cal, 8 g of protein, 8 g of fat, and 11 g of carbohydrates. (Source: *Home and Garden Bulletin No. 72*, U.S. Government Printing Office, Washington, D.C. 20402)

- Write 1×4 matrices **P**, **G**, and **M** that represent the nutritional values of each food.
- Find $3\mathbf{P} + 2\mathbf{G} + 2\mathbf{M}$ and tell what the entries represent.

33. **Food Service Management.** The food service manager at a large hospital is concerned about maintaining reasonable food costs. The table below lists the cost per serving, in dollars, for items on four menus.

Menu	Meat	Potato	Vegetable	Salad	Dessert
1	1.50	0.15	0.26	0.23	0.64
2	1.55	0.14	0.24	0.21	0.75
3	1.62	0.22	0.31	0.28	0.53
4	1.70	0.20	0.29	0.33	0.68

On a particular day, a dietician orders 65 meals from menu 1, 48 from menu 2, 93 from menu 3, and 57 from menu 4.

- Write the information in the table as a 4×5 matrix **M**.
- Write a row matrix **N** that represents the number of each menu ordered.
- Find the product **NM**.
- State what the entries of **NM** represent.

34. **Food Service Management.** A college food service manager uses a table like the one below to list the number of units of ingredients, by weight, required for various menu items.

	White Cake	Bread	Coffee Cake	Sugar Cookies
Flour	1	2.5	0.75	0.5
Milk	0	0.5	0.25	0
Eggs	0.75	0.25	0.5	0.5
Butter	0.5	0	0.5	1

The cost per unit of each ingredient is 25 cents for flour, 34 cents for milk, 54 cents for eggs, and 83 cents for butter.

- Write the information in the table as a 4×4 matrix **M**.
 - Write a row matrix **C** that represents the cost per unit of each ingredient.
 - Find the product **CM**.
 - State what the entries of **CM** represent.
35. **Production Cost.** Karin supplies two small campus coffee shops with homemade chocolate chip cookies, oatmeal cookies, and peanut butter cookies. The table below shows the number of each type of cookie, in dozens, that Karin sold in one week.

	Mugsy's Coffee Shop	The Coffee Club
Chocolate Chip	8	15
Oatmeal	6	10
Peanut Butter	4	3

Karin spends \$4 for the ingredients for one dozen chocolate chip cookies, \$2.50 for the ingredients for one dozen oatmeal cookies, and \$3 for the ingredients for one dozen peanut butter cookies.

- Write the information in the table as a 3×2 matrix **S**.
- Write a row matrix **C** that represents the cost, per dozen, of the ingredients for each type of cookie.
- Find the product **CS**.
- State what the entries of **CS** represent.

36. **Profit.** A manufacturer produces exterior plywood, interior plywood, and fiberboard, which are shipped to two distributors. The table below shows the number of units of each type of product that are shipped to each warehouse.

	Distributor 1	Distributor 2
Exterior Plywood	900	500
Interior Plywood	450	1000
Fiberboard	600	700

The profits from each unit of exterior plywood, interior plywood, and fiberboard are \$5, \$8, and \$4, respectively.

- Write the information in the table as a 3×2 matrix \mathbf{M} .
 - Write a row matrix \mathbf{P} that represents the profit, per unit, of each type of product.
 - Find the product \mathbf{PM} .
 - State what the entries of \mathbf{PM} represent.
37. **Profit.** In Exercise 35, suppose that Karin's profits on one dozen chocolate chip, oatmeal, and peanut butter cookies are \$6, \$4.50, and \$5.20, respectively.
- Write a row matrix \mathbf{P} that represents this information.
 - Use the matrices \mathbf{S} and \mathbf{P} to find Karin's total profit from each coffee shop.
38. **Production Cost.** In Exercise 36, suppose that the manufacturer's production costs for each unit of exterior plywood, interior plywood, and fiberboard are \$20, \$25, and \$15, respectively.
- Write a row matrix \mathbf{C} that represents this information.
 - Use the matrices \mathbf{M} and \mathbf{C} to find the total production cost for the products shipped to each distributor.

Write a matrix equation equivalent to the system of equations.

39. $2x - 3y = 7,$
 $x + 5y = -6$

40. $-x + y = 3,$
 $5x - 4y = 16$

41. $x + y - 2z = 6,$
 $3x - y + z = 7,$
 $2x + 5y - 3z = 8$

42. $3x - y + z = 1,$
 $x + 2y - z = 3,$
 $4x + 3y - 2z = 11$

43. $3x - 2y + 4z = 17,$
 $2x + y - 5z = 13$

44. $3x + 2y + 5z = 9,$
 $4x - 3y + 2z = 10$

45. $-4w + x - y + 2z = 12,$
 $w + 2x - y - z = 0,$
 $-w + x + 4y - 3z = 1,$
 $2w + 3x + 5y - 7z = 9$

46. $12w + 2x + 4y - 5z = 2,$
 $-w + 4x - y + 12z = 5,$
 $2w - x + 4y = 13,$
 $2x + 10y + z = 5$

Skill Maintenance

In Exercises 47–50:

- Find the vertex.
- Find the axis of symmetry.
- Determine whether there is a maximum or minimum value and find that value.
- Graph the function.

47. $f(x) = x^2 - x - 6$

48. $f(x) = 2x^2 - 5x - 3$

49. $f(x) = -x^2 - 3x + 2$

50. $f(x) = -3x^2 + 4x + 4$

Synthesis

For Exercises 51–54, let

$$\mathbf{A} = \begin{bmatrix} -1 & 0 \\ 2 & 1 \end{bmatrix} \quad \text{and} \quad \mathbf{B} = \begin{bmatrix} 1 & -1 \\ 0 & 2 \end{bmatrix}.$$

51. Show that

$$(\mathbf{A} + \mathbf{B})(\mathbf{A} - \mathbf{B}) \neq \mathbf{A}^2 - \mathbf{B}^2,$$

where

$$\mathbf{A}^2 = \mathbf{AA} \quad \text{and} \quad \mathbf{B}^2 = \mathbf{BB}.$$

52. Show that

$$(\mathbf{A} + \mathbf{B})(\mathbf{A} + \mathbf{B}) \neq \mathbf{A}^2 + 2\mathbf{AB} + \mathbf{B}^2.$$

53. Show that

$$(\mathbf{A} + \mathbf{B})(\mathbf{A} - \mathbf{B}) = \mathbf{A}^2 + \mathbf{BA} - \mathbf{AB} - \mathbf{B}^2.$$

54. Show that

$$(\mathbf{A} + \mathbf{B})(\mathbf{A} + \mathbf{B}) = \mathbf{A}^2 + \mathbf{BA} + \mathbf{AB} + \mathbf{B}^2.$$

In Exercises 55–59, let

$$\mathbf{A} = \begin{bmatrix} a_{11} & a_{12} & a_{13} & \cdots & a_{1n} \\ a_{21} & a_{22} & a_{23} & \cdots & a_{2n} \\ a_{31} & a_{32} & a_{33} & \cdots & a_{3n} \\ \vdots & \vdots & \vdots & & \vdots \\ a_{m1} & a_{m2} & a_{m3} & \cdots & a_{mn} \end{bmatrix},$$

$$\mathbf{B} = \begin{bmatrix} b_{11} & b_{12} & b_{13} & \cdots & b_{1n} \\ b_{21} & b_{22} & b_{23} & \cdots & b_{2n} \\ b_{31} & b_{32} & b_{33} & \cdots & b_{3n} \\ \vdots & \vdots & \vdots & & \vdots \\ b_{m1} & b_{m2} & b_{m3} & \cdots & b_{mn} \end{bmatrix},$$

$$\text{and } \mathbf{C} = \begin{bmatrix} c_{11} & c_{12} & c_{13} & \cdots & c_{1n} \\ c_{21} & c_{22} & c_{23} & \cdots & c_{2n} \\ c_{31} & c_{32} & c_{33} & \cdots & c_{3n} \\ \vdots & \vdots & \vdots & & \vdots \\ c_{m1} & c_{m2} & c_{m3} & \cdots & c_{mn} \end{bmatrix},$$

and let k and l be any scalars.

55. Prove that $\mathbf{A} + \mathbf{B} = \mathbf{B} + \mathbf{A}$.

56. Prove that $\mathbf{A} + (\mathbf{B} + \mathbf{C}) = (\mathbf{A} + \mathbf{B}) + \mathbf{C}$.

57. Prove that $(kl)\mathbf{A} = k(l\mathbf{A})$.

58. Prove that $k(\mathbf{A} + \mathbf{B}) = k\mathbf{A} + k\mathbf{B}$.

59. Prove that $(k + l)\mathbf{A} = k\mathbf{A} + l\mathbf{A}$.

Mid-Chapter Mixed Review

Determine whether the statement is true or false.

1. For a system of two linear equations in two variables, if the graphs of the equations are parallel lines, then the system of equations has infinitely many solutions. [9.1]
2. One of the properties of a matrix written in row-echelon form is that all the rows consisting entirely of 0's are at the bottom of the matrix. [9.3]
3. We can multiply two matrices only when the number of columns in the first matrix is equal to the number of rows in the second matrix. [9.4]
4. Addition of matrices is not commutative. [9.4]

Solve. [9.1], [9.2]

$$\begin{aligned} 5. \quad & 2x + y = -4, \\ & x = y - 5 \end{aligned}$$

$$\begin{aligned} 7. \quad & 2x - 3y = 8, \\ & 3x + 2y = -1 \end{aligned}$$

$$\begin{aligned} 9. \quad & x + 2y + 3z = 4, \\ & x - 2y + z = 2, \\ & 2x - 6y + 4z = 7 \end{aligned}$$

$$\begin{aligned} 6. \quad & x + y = 4, \\ & y = 2 - x \end{aligned}$$

$$\begin{aligned} 8. \quad & x - 3y = 1, \\ & 6y = 2x - 2 \end{aligned}$$

10. **e-Commerce.** computerwarehouse.com charges \$3 for shipping orders up to 10 lb, \$5 for orders from 10 lb up to 15 lb, and \$7.50 for orders of 15 lb or more. One day shipping charges for 150 orders totaled \$680. The number of orders under 10 lb was three times the number of orders weighing 15 lb or more. Find the number of packages shipped at each rate. [9.2]

Solve the system of equations using Gaussian elimination or Gauss–Jordan elimination. [9.3]

$$\begin{aligned} 11. \quad & 2x + y = 5, \\ & 3x + 2y = 6 \end{aligned}$$

$$\begin{aligned} 12. \quad & 3x + 2y - 3z = -2, \\ & 2x + 3y + 2z = -2, \\ & x + 4y + 4z = 1 \end{aligned}$$

For Exercises 13–20, let

$$\mathbf{A} = \begin{bmatrix} 3 & -1 \\ 5 & 4 \end{bmatrix}, \quad \mathbf{B} = \begin{bmatrix} -2 & 6 \\ 1 & -3 \end{bmatrix}, \quad \mathbf{C} = \begin{bmatrix} -4 & 1 & -1 \\ 2 & 3 & -2 \end{bmatrix}, \quad \text{and} \quad \mathbf{D} = \begin{bmatrix} -2 & 3 & 0 \\ 1 & -1 & 2 \\ -3 & 4 & 1 \end{bmatrix}.$$

Find each of the following. [9.4]

13. $\mathbf{A} + \mathbf{B}$

14. $\mathbf{B} - \mathbf{A}$

15. $4\mathbf{D}$

16. $2\mathbf{A} + 3\mathbf{B}$

17. \mathbf{AB}

18. \mathbf{BA}

19. \mathbf{BC}

20. \mathbf{DC}

21. Write a matrix equation equivalent to the following system of equations: [9.4]

$$\begin{aligned} 2x - y + 3z &= 7, \\ x + 2y - z &= 3, \\ 3x - 4y + 2z &= 5. \end{aligned}$$

Collaborative Discussion and Writing

22. Explain in your own words when the elimination method for solving a system of equations is preferable to the substitution method. [9.1]

23. Given two linear equations in three variables, $Ax + By + Cz = D$ and $Ex + Fy + Gz = H$, explain how you could find a third equation such that the system contains dependent equations. [9.2]

24. Explain in your own words why the augmented matrix below represents a system of dependent equations. [9.3]

25. Is it true that if $\mathbf{AB} = \mathbf{0}$, for matrices \mathbf{A} and \mathbf{B} , then $\mathbf{A} = \mathbf{0}$ or $\mathbf{B} = \mathbf{0}$? Why or why not? [9.4]

$$\left[\begin{array}{ccc|c} 1 & -3 & 2 & -5 \\ 0 & 1 & -4 & 8 \\ 0 & 0 & 0 & 0 \end{array} \right]$$

Inverses of Matrices

9.5

- ▶ Find the inverse of a square matrix, if it exists.
- ▶ Use inverses of matrices to solve systems of equations.

In this section, we continue our study of matrix algebra, finding the **multiplicative inverse**, or simply **inverse**, of a square matrix, if it exists. Then we use such inverses to solve systems of equations.

▶ The Identity Matrix

Recall that, for real numbers, $a \cdot 1 = 1 \cdot a = a$; 1 is the multiplicative identity. A multiplicative identity matrix is very similar to the number 1.

Identity Matrix

For any positive integer n , the $n \times n$ **identity matrix** is an $n \times n$ matrix with 1's on the main diagonal and 0's elsewhere and is denoted by

$$\mathbf{I} = \begin{bmatrix} 1 & 0 & 0 & \cdots & 0 \\ 0 & 1 & 0 & \cdots & 0 \\ 0 & 0 & 1 & \cdots & 0 \\ \vdots & \vdots & \vdots & \ddots & \vdots \\ 0 & 0 & 0 & \cdots & 1 \end{bmatrix}.$$

Then $\mathbf{AI} = \mathbf{IA} = \mathbf{A}$, for any $n \times n$ matrix \mathbf{A} .

EXAMPLE 1 For

$$\mathbf{A} = \begin{bmatrix} 4 & -7 \\ -3 & 2 \end{bmatrix} \quad \text{and} \quad \mathbf{I} = \begin{bmatrix} 1 & 0 \\ 0 & 1 \end{bmatrix},$$

find each of the following.

a) \mathbf{AI}

b) \mathbf{IA}

Solution

$$\begin{aligned} \text{a) } \mathbf{AI} &= \begin{bmatrix} 4 & -7 \\ -3 & 2 \end{bmatrix} \begin{bmatrix} 1 & 0 \\ 0 & 1 \end{bmatrix} \\ &= \begin{bmatrix} 4 \cdot 1 - 7 \cdot 0 & 4 \cdot 0 - 7 \cdot 1 \\ -3 \cdot 1 + 2 \cdot 0 & -3 \cdot 0 + 2 \cdot 1 \end{bmatrix} = \begin{bmatrix} 4 & -7 \\ -3 & 2 \end{bmatrix} = \mathbf{A} \end{aligned}$$

$$\begin{aligned}
 \text{b) } \mathbf{IA} &= \begin{bmatrix} 1 & 0 \\ 0 & 1 \end{bmatrix} \begin{bmatrix} 4 & -7 \\ -3 & 2 \end{bmatrix} \\
 &= \begin{bmatrix} 1 \cdot 4 + 0(-3) & 1(-7) + 0 \cdot 2 \\ 0 \cdot 4 + 1(-3) & 0(-7) + 1 \cdot 2 \end{bmatrix} \\
 &= \begin{bmatrix} 4 & -7 \\ -3 & 2 \end{bmatrix} = \mathbf{A}
 \end{aligned}$$



► The Inverse of a Matrix

Recall that for every nonzero real number a , there is a multiplicative inverse $1/a$, or a^{-1} , such that $a \cdot a^{-1} = a^{-1} \cdot a = 1$. The multiplicative inverse of a matrix behaves in a similar manner.

Inverse of a Matrix

For an $n \times n$ matrix \mathbf{A} , if there is a matrix \mathbf{A}^{-1} for which $\mathbf{A}^{-1} \cdot \mathbf{A} = \mathbf{I} = \mathbf{A} \cdot \mathbf{A}^{-1}$, then \mathbf{A}^{-1} is the **inverse** of \mathbf{A} .

We read \mathbf{A}^{-1} as “ \mathbf{A} inverse.” Note that not every matrix has an inverse.

EXAMPLE 2 Verify that

$$\mathbf{B} = \begin{bmatrix} 4 & -3 \\ 3 & -2 \end{bmatrix} \text{ is the inverse of } \mathbf{A} = \begin{bmatrix} -2 & 3 \\ -3 & 4 \end{bmatrix}.$$

Solution We show that $\mathbf{BA} = \mathbf{I} = \mathbf{AB}$.

$$\mathbf{BA} = \begin{bmatrix} 4 & -3 \\ 3 & -2 \end{bmatrix} \begin{bmatrix} -2 & 3 \\ -3 & 4 \end{bmatrix} = \begin{bmatrix} 1 & 0 \\ 0 & 1 \end{bmatrix}$$

$$\mathbf{AB} = \begin{bmatrix} -2 & 3 \\ -3 & 4 \end{bmatrix} \begin{bmatrix} 4 & -3 \\ 3 & -2 \end{bmatrix} = \begin{bmatrix} 1 & 0 \\ 0 & 1 \end{bmatrix}$$

Now Try Exercise 1.

We can find the inverse of a square matrix, if it exists, by using row-equivalent operations as in the Gauss–Jordan elimination method. For example, consider the matrix

$$\mathbf{A} = \begin{bmatrix} -2 & 3 \\ -3 & 4 \end{bmatrix}.$$

To find its inverse, we first form an **augmented matrix** consisting of \mathbf{A} on the left side and the 2×2 identity matrix on the right side:

$$\left[\begin{array}{cc|cc} -2 & 3 & 1 & 0 \\ -3 & 4 & 0 & 1 \end{array} \right] \quad \text{Augmented matrix}$$

\uparrow \uparrow
The 2×2 matrix A **The 2×2 identity matrix**

Then we attempt to transform the augmented matrix to one of the form

$$\left[\begin{array}{cc|cc} 1 & 0 & a & b \\ 0 & 1 & c & d \end{array} \right]$$

\uparrow \uparrow
The 2×2 identity matrix **The matrix A^{-1}**

If we can do this, the matrix on the right, $\begin{bmatrix} a & b \\ c & d \end{bmatrix}$, is A^{-1} .

EXAMPLE 3 Find A^{-1} , where

$$A = \begin{bmatrix} -2 & 3 \\ -3 & 4 \end{bmatrix}.$$

Solution First, we write the augmented matrix. Then we transform it to the desired form.

$$\left[\begin{array}{cc|cc} -2 & 3 & 1 & 0 \\ -3 & 4 & 0 & 1 \end{array} \right]$$

$$\left[\begin{array}{cc|cc} 1 & -\frac{3}{2} & -\frac{1}{2} & 0 \\ -3 & 4 & 0 & 1 \end{array} \right] \quad \text{New row 1} = -\frac{1}{2}(\text{row 1})$$

$$\left[\begin{array}{cc|cc} 1 & -\frac{3}{2} & -\frac{1}{2} & 0 \\ 0 & -\frac{1}{2} & -\frac{3}{2} & 1 \end{array} \right] \quad \text{New row 2} = 3(\text{row 1}) + \text{row 2}$$

$$\left[\begin{array}{cc|cc} 1 & -\frac{3}{2} & -\frac{1}{2} & 0 \\ 0 & 1 & 3 & -2 \end{array} \right] \quad \text{New row 2} = -2(\text{row 2})$$

$$\left[\begin{array}{cc|cc} 1 & 0 & 4 & -3 \\ 0 & 1 & 3 & -2 \end{array} \right] \quad \text{New row 1} = \frac{3}{2}(\text{row 2}) + \text{row 1}$$

Thus,

$$A^{-1} = \begin{bmatrix} 4 & -3 \\ 3 & -2 \end{bmatrix},$$

which we verified in Example 2.

TECHNOLOGY CONNECTION

The x^{-1} key on a graphing calculator can also be used to find the inverse of a matrix like the one in Example 3.

$$[A]^{-1} \quad \begin{bmatrix} 4 & -3 \\ 3 & -2 \end{bmatrix}$$

Now Try Exercise 5.

EXAMPLE 4 Find \mathbf{A}^{-1} , where

$$\mathbf{A} = \begin{bmatrix} 1 & 2 & -1 \\ 3 & 5 & 3 \\ 2 & 4 & 3 \end{bmatrix}.$$

Solution First, we write the augmented matrix. Then we transform it to the desired form.

$$\left[\begin{array}{ccc|ccc} 1 & 2 & -1 & 1 & 0 & 0 \\ 3 & 5 & 3 & 0 & 1 & 0 \\ 2 & 4 & 3 & 0 & 0 & 1 \end{array} \right]$$

$$\left[\begin{array}{ccc|ccc} 1 & 2 & -1 & 1 & 0 & 0 \\ 0 & -1 & 6 & -3 & 1 & 0 \\ 0 & 0 & 5 & -2 & 0 & 1 \end{array} \right]$$

New row 2 = $-3(\text{row } 1) + \text{row } 2$

New row 3 = $-2(\text{row } 1) + \text{row } 3$

$$\left[\begin{array}{ccc|ccc} 1 & 2 & -1 & 1 & 0 & 0 \\ 0 & -1 & 6 & -3 & 1 & 0 \\ 0 & 0 & 1 & -\frac{2}{5} & 0 & \frac{1}{5} \end{array} \right]$$

New row 3 = $\frac{1}{5}(\text{row } 3)$

$$\left[\begin{array}{ccc|ccc} 1 & 2 & 0 & \frac{3}{5} & 0 & \frac{1}{5} \\ 0 & -1 & 0 & -\frac{3}{5} & 1 & -\frac{6}{5} \\ 0 & 0 & 1 & -\frac{2}{5} & 0 & \frac{1}{5} \end{array} \right]$$

New row 1 = $\text{row } 3 + \text{row } 1$

New row 2 = $-6(\text{row } 3) + \text{row } 2$

$$\left[\begin{array}{ccc|ccc} 1 & 0 & 0 & -\frac{3}{5} & 2 & -\frac{11}{5} \\ 0 & -1 & 0 & -\frac{3}{5} & 1 & -\frac{6}{5} \\ 0 & 0 & 1 & -\frac{2}{5} & 0 & \frac{1}{5} \end{array} \right]$$

New row 1 = $2(\text{row } 2) + \text{row } 1$

$$\left[\begin{array}{ccc|ccc} 1 & 0 & 0 & -\frac{3}{5} & 2 & -\frac{11}{5} \\ 0 & 1 & 0 & \frac{3}{5} & -1 & \frac{6}{5} \\ 0 & 0 & 1 & -\frac{2}{5} & 0 & \frac{1}{5} \end{array} \right]$$

New row 2 = $-1(\text{row } 2)$

Thus,

$$\mathbf{A}^{-1} = \begin{bmatrix} -\frac{3}{5} & 2 & -\frac{11}{5} \\ \frac{3}{5} & -1 & \frac{6}{5} \\ -\frac{2}{5} & 0 & \frac{1}{5} \end{bmatrix}.$$

 Now Try Exercise 11.

TECHNOLOGY CONNECTION

When we try to find the inverse of a noninvertible, or singular, matrix using a graphing calculator, the calculator returns an error message similar to ERR: SINGULAR MATRIX.

If a matrix has an inverse, we say that it is **invertible**, or **nonsingular**. When we cannot obtain the identity matrix on the left using the Gauss–Jordan method, then no inverse exists. This occurs when we obtain a row consisting entirely of 0's in either of the two matrices in the augmented matrix. In this case, we say that \mathbf{A} is a **singular matrix**.

MATRIX EQUATIONS

REVIEW SECTION 9.4

► Solving Systems of Equations

We can write a system of n linear equations in n variables as a matrix equation $\mathbf{AX} = \mathbf{B}$. If \mathbf{A} has an inverse, then the system of equations has a unique solution that can be found by solving for \mathbf{X} , as follows:

$$\begin{aligned} \mathbf{AX} &= \mathbf{B} \\ \mathbf{A}^{-1}(\mathbf{AX}) &= \mathbf{A}^{-1}\mathbf{B} && \text{Multiplying by } \mathbf{A}^{-1} \text{ on the left on both sides} \\ (\mathbf{A}^{-1}\mathbf{A})\mathbf{X} &= \mathbf{A}^{-1}\mathbf{B} && \text{Using the associative property} \\ &&& \text{of matrix multiplication} \\ \mathbf{IX} &= \mathbf{A}^{-1}\mathbf{B} && \mathbf{A}^{-1}\mathbf{A} = \mathbf{I} \\ \mathbf{X} &= \mathbf{A}^{-1}\mathbf{B}. && \mathbf{IX} = \mathbf{X} \end{aligned}$$

Matrix Solutions of Systems of Equations

For a system of n linear equations in n variables, $\mathbf{AX} = \mathbf{B}$, if \mathbf{A} is an invertible matrix, then the unique solution of the system is given by

$$\mathbf{X} = \mathbf{A}^{-1}\mathbf{B}.$$

Since matrix multiplication is not commutative in general, care must be taken to multiply *on the left* by \mathbf{A}^{-1} .

EXAMPLE 5 Use an inverse matrix to solve the following system of equations:

$$\begin{aligned} -2x + 3y &= 4, \\ -3x + 4y &= 5. \end{aligned}$$

Solution We write an equivalent matrix equation, $\mathbf{AX} = \mathbf{B}$:

$$\begin{bmatrix} -2 & 3 \\ -3 & 4 \end{bmatrix} \cdot \begin{bmatrix} x \\ y \end{bmatrix} = \begin{bmatrix} 4 \\ 5 \end{bmatrix}$$

$$\mathbf{A} \cdot \mathbf{X} = \mathbf{B}$$

In Example 3, we found that

$$\mathbf{A}^{-1} = \begin{bmatrix} 4 & -3 \\ 3 & -2 \end{bmatrix}.$$

We also verified this in Example 2. Now we have

$$\mathbf{X} = \mathbf{A}^{-1}\mathbf{B}$$

$$\begin{bmatrix} x \\ y \end{bmatrix} = \begin{bmatrix} 4 & -3 \\ 3 & -2 \end{bmatrix} \begin{bmatrix} 4 \\ 5 \end{bmatrix} = \begin{bmatrix} 1 \\ 2 \end{bmatrix}.$$

The solution of the system of equations is $(1, 2)$.

TECHNOLOGY CONNECTION

To use a graphing calculator to solve the system of equations in Example 5, we enter \mathbf{A} and \mathbf{B} and then enter the notation $\mathbf{A}^{-1}\mathbf{B}$ on the home screen.

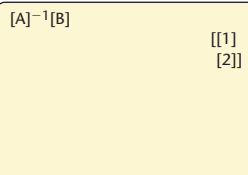

9.5

Exercise Set

Determine whether \mathbf{B} is the inverse of \mathbf{A} .

$$1. \mathbf{A} = \begin{bmatrix} 1 & -3 \\ -2 & 7 \end{bmatrix}, \mathbf{B} = \begin{bmatrix} 7 & 3 \\ 2 & 1 \end{bmatrix}$$

$$2. \mathbf{A} = \begin{bmatrix} 3 & 2 \\ 4 & 3 \end{bmatrix}, \mathbf{B} = \begin{bmatrix} 3 & -2 \\ -4 & 3 \end{bmatrix}$$

$$3. \mathbf{A} = \begin{bmatrix} -1 & -1 & 6 \\ 1 & 0 & -2 \\ 1 & 0 & -3 \end{bmatrix}, \mathbf{B} = \begin{bmatrix} 2 & 3 & 2 \\ 3 & 3 & 4 \\ 1 & 1 & 1 \end{bmatrix}$$

$$4. \mathbf{A} = \begin{bmatrix} -2 & 0 & -3 \\ 5 & 1 & 7 \\ -3 & 0 & 4 \end{bmatrix}, \mathbf{B} = \begin{bmatrix} 4 & 0 & -3 \\ 1 & 1 & 1 \\ -3 & 0 & 2 \end{bmatrix}$$

Use the Gauss–Jordan method to find \mathbf{A}^{-1} , if it exists. Check your answers by finding $\mathbf{A}^{-1}\mathbf{A}$ and $\mathbf{A}\mathbf{A}^{-1}$.

$$5. \mathbf{A} = \begin{bmatrix} 3 & 2 \\ 5 & 3 \end{bmatrix}$$

$$6. \mathbf{A} = \begin{bmatrix} 3 & 5 \\ 1 & 2 \end{bmatrix}$$

$$7. \mathbf{A} = \begin{bmatrix} 6 & 9 \\ 4 & 6 \end{bmatrix}$$

$$8. \mathbf{A} = \begin{bmatrix} -4 & -6 \\ 2 & 3 \end{bmatrix}$$

$$9. \mathbf{A} = \begin{bmatrix} 4 & -3 \\ 1 & -2 \end{bmatrix}$$

$$10. \mathbf{A} = \begin{bmatrix} 0 & -1 \\ 1 & 0 \end{bmatrix}$$

$$11. \mathbf{A} = \begin{bmatrix} 3 & 1 & 0 \\ 1 & 1 & 1 \\ 1 & -1 & 2 \end{bmatrix}$$

$$12. \mathbf{A} = \begin{bmatrix} 1 & 0 & 1 \\ 2 & 1 & 0 \\ 1 & -1 & 1 \end{bmatrix}$$

$$13. \mathbf{A} = \begin{bmatrix} 1 & -4 & 8 \\ 1 & -3 & 2 \\ 2 & -7 & 10 \end{bmatrix}$$

$$14. \mathbf{A} = \begin{bmatrix} -2 & 5 & 3 \\ 4 & -1 & 3 \\ 7 & -2 & 5 \end{bmatrix}$$

$$15. \mathbf{A} = \begin{bmatrix} 2 & 3 & 2 \\ 3 & 3 & 4 \\ -1 & -1 & -1 \end{bmatrix}$$

$$16. \mathbf{A} = \begin{bmatrix} 1 & 2 & 3 \\ 2 & -1 & -2 \\ -1 & 3 & 3 \end{bmatrix}$$

$$17. \mathbf{A} = \begin{bmatrix} 1 & 2 & -1 \\ -2 & 0 & 1 \\ 1 & -1 & 0 \end{bmatrix}$$

$$18. \mathbf{A} = \begin{bmatrix} 7 & -1 & -9 \\ 2 & 0 & -4 \\ -4 & 0 & 6 \end{bmatrix}$$

$$19. \mathbf{A} = \begin{bmatrix} 1 & 3 & -1 \\ 0 & 2 & -1 \\ 1 & 1 & 0 \end{bmatrix}$$

$$20. \mathbf{A} = \begin{bmatrix} -1 & 0 & -1 \\ -1 & 1 & 0 \\ 0 & 1 & 1 \end{bmatrix}$$

$$21. \mathbf{A} = \begin{bmatrix} 1 & 2 & 3 & 4 \\ 0 & 1 & 3 & -5 \\ 0 & 0 & 1 & -2 \\ 0 & 0 & 0 & -1 \end{bmatrix}$$

$$22. \mathbf{A} = \begin{bmatrix} -2 & -3 & 4 & 1 \\ 0 & 1 & 1 & 0 \\ 0 & 4 & -6 & 1 \\ -2 & -2 & 5 & 1 \end{bmatrix}$$

$$23. \mathbf{A} = \begin{bmatrix} 1 & -14 & 7 & 38 \\ -1 & 2 & 1 & -2 \\ 1 & 2 & -1 & -6 \\ 1 & -2 & 3 & 6 \end{bmatrix}$$

$$24. \mathbf{A} = \begin{bmatrix} 10 & 20 & -30 & 15 \\ 3 & -7 & 14 & -8 \\ -7 & -2 & -1 & 2 \\ 4 & 4 & -3 & 1 \end{bmatrix}$$

In Exercises 25–28, a system of equations is given, together with the inverse of the coefficient matrix. Use the inverse of the coefficient matrix to solve the system of equations.

$$25. \begin{cases} 11x + 3y = -4, \\ 7x + 2y = 5; \end{cases} \mathbf{A}^{-1} = \begin{bmatrix} 2 & -3 \\ -7 & 11 \end{bmatrix}$$

$$26. \begin{cases} 8x + 5y = -6, \\ 5x + 3y = 2; \end{cases} \mathbf{A}^{-1} = \begin{bmatrix} -3 & 5 \\ 5 & -8 \end{bmatrix}$$

$$27. \begin{cases} 3x + y = 2, \\ 2x - y + 2z = -5, \\ x + y + z = 5; \end{cases} \mathbf{A}^{-1} = \frac{1}{9} \begin{bmatrix} 3 & 1 & -2 \\ 0 & -3 & 6 \\ -3 & 2 & 5 \end{bmatrix}$$

$$28. \begin{cases} y - z = -4, \\ 4x + y = -3, \\ 3x - y + 3z = 1; \end{cases} \mathbf{A}^{-1} = \frac{1}{5} \begin{bmatrix} -3 & 2 & -1 \\ 12 & -3 & 4 \\ 7 & -3 & 4 \end{bmatrix}$$

Solve the system of equations using the inverse of the coefficient matrix of the equivalent matrix equation.

$$29. \begin{cases} 4x + 3y = 2, \\ x - 2y = 6 \end{cases}$$

$$30. \begin{cases} 2x - 3y = 7, \\ 4x + y = -7 \end{cases}$$

$$31. \begin{cases} 5x + y = 2, \\ 3x - 2y = -4 \end{cases}$$

$$32. \begin{cases} x - 6y = 5, \\ -x + 4y = -5 \end{cases}$$

$$33. \begin{cases} x + z = 1, \\ 2x + y = 3, \\ x - y + z = 4 \end{cases}$$

$$34. \begin{cases} x + 2y + 3z = -1, \\ 2x - 3y + 4z = 2, \\ -3x + 5y - 6z = 4 \end{cases}$$

$$35. \begin{cases} 2x + 3y + 4z = 2, \\ x - 4y + 3z = 2, \\ 5x + y + z = -4 \end{cases}$$

$$36. \begin{cases} x + y = 2, \\ 3x + 2z = 5, \\ 2x + 3y - 3z = 9 \end{cases}$$

$$37. \begin{cases} 2w - 3x + 4y - 5z = 0, \\ 3w - 2x + 7y - 3z = 2, \\ w + x - y + z = 1, \\ -w - 3x - 6y + 4z = 6 \end{cases}$$

$$38. \begin{cases} 5w - 4x + 3y - 2z = -6, \\ w + 4x - 2y + 3z = -5, \\ 2w - 3x + 6y - 9z = 14, \\ 3w - 5x + 2y - 4z = -3 \end{cases}$$

39. **Sales.** Kayla sold a total of 145 Italian sausages and hot dogs from her curbside pushcart and collected \$242.05. She sold 45 more hot dogs than sausages. How many of each did she sell?

40. **Price of School Supplies.** Rubio bought 4 lab record books and 3 highlighters for \$17.83. Marcus bought

3 lab record books and 2 highlighters for \$13.05. Find the price of each item.

41. **Cost.** Green-Up Landscaping bought 4 tons of topsoil, 3 tons of mulch, and 6 tons of pea gravel for \$2825. The next week the firm bought 5 tons of topsoil, 2 tons of mulch, and 5 tons of pea gravel for \$2663. Pea gravel costs \$17 less per ton than topsoil. Find the price per ton for each item.

42. **Investment.** Donna receives \$230 per year in simple interest from three investments totaling \$8500. Part is invested at 2.2%, part at 2.65%, and the rest at 3.05%. There is \$1500 more invested at 3.05% than at 2.2%. Find the amount invested at each rate.

Skill Maintenance

Use synthetic division to find the function values.

$$43. f(x) = x^3 - 6x^2 + 4x - 8; \text{ find } f(-2)$$

$$44. f(x) = 2x^4 - x^3 + 5x^2 + 6x - 4; \text{ find } f(3)$$

Solve.

$$45. 2x^2 + x = 7$$

$$46. \frac{1}{x+1} - \frac{6}{x-1} = 1$$

$$47. \sqrt{2x+1} - 1 = \sqrt{2x-4}$$

$$48. x - \sqrt{x} - 6 = 0$$

Factor the polynomial $f(x)$.

$$49. f(x) = x^3 - 3x^2 - 6x + 8$$

$$50. f(x) = x^4 + 2x^3 - 16x^2 - 2x + 15$$

Synthesis

State the conditions under which \mathbf{A}^{-1} exists. Then find a formula for \mathbf{A}^{-1} .

$$51. \mathbf{A} = [x] \qquad 52. \mathbf{A} = \begin{bmatrix} x & 0 \\ 0 & y \end{bmatrix}$$

$$53. \mathbf{A} = \begin{bmatrix} 0 & 0 & x \\ 0 & y & 0 \\ z & 0 & 0 \end{bmatrix} \qquad 54. \mathbf{A} = \begin{bmatrix} x & 1 & 1 & 1 \\ 0 & y & 0 & 0 \\ 0 & 0 & z & 0 \\ 0 & 0 & 0 & w \end{bmatrix}$$

Determinants and Cramer's Rule

9.6

- ▶ Evaluate determinants of square matrices.
- ▶ Use Cramer's rule to solve systems of equations.

▶ Determinants of Square Matrices

With every square matrix, we associate a number called its *determinant*.

Determinant of a 2×2 Matrix

The **determinant** of the matrix $\begin{bmatrix} a & c \\ b & d \end{bmatrix}$ is denoted $\begin{vmatrix} a & c \\ b & d \end{vmatrix}$ and is defined as

$$\begin{vmatrix} a & c \\ b & d \end{vmatrix} = ad - bc.$$

EXAMPLE 1 Evaluate: $\begin{vmatrix} \sqrt{2} & -3 \\ -4 & -\sqrt{2} \end{vmatrix}$.

Solution

$$\begin{aligned} & \begin{vmatrix} \sqrt{2} & -3 \\ -4 & -\sqrt{2} \end{vmatrix} && \text{The arrows indicate the products involved.} \\ & = \sqrt{2}(-\sqrt{2}) - (-4)(-3) \\ & = -2 - 12 \\ & = -14 \end{aligned}$$

➔ Now Try Exercise 1.

We now consider a way to evaluate determinants of square matrices of order 3×3 or higher.

▶ Evaluating Determinants Using Cofactors

Often we first find minors and cofactors of matrices in order to evaluate determinants.

Minor

For a square matrix $\mathbf{A} = [a_{ij}]$, the **minor** M_{ij} of an entry a_{ij} is the determinant of the matrix formed by deleting the i th row and the j th column of \mathbf{A} .

EXAMPLE 2 For the matrix

$$\mathbf{A} = [a_{ij}] = \begin{bmatrix} -8 & 0 & 6 \\ 4 & -6 & 7 \\ -1 & -3 & 5 \end{bmatrix},$$

find each of the following.

a) M_{11}

b) M_{23}

Solution

a) For M_{11} , we delete the first row and the first column and find the determinant of the 2×2 matrix formed by the remaining entries.

$$\begin{bmatrix} \cancel{-8} & \cancel{0} & \cancel{6} \\ 4 & -6 & 7 \\ -1 & -3 & 5 \end{bmatrix} \quad M_{11} = \begin{vmatrix} -6 & 7 \\ -3 & 5 \end{vmatrix} \\ = (-6) \cdot 5 - (-3) \cdot 7 \\ = -30 - (-21) \\ = -30 + 21 \\ = -9$$

b) For M_{23} , we delete the second row and the third column and find the determinant of the 2×2 matrix formed by the remaining entries.

$$\begin{bmatrix} -8 & 0 & \cancel{6} \\ \cancel{4} & \cancel{-6} & \cancel{7} \\ -1 & -3 & 5 \end{bmatrix} \quad M_{23} = \begin{vmatrix} -8 & 0 \\ -1 & -3 \end{vmatrix} \\ = -8(-3) - (-1)0 \\ = 24$$

 **Now Try Exercise 9.**

Cofactor

For a square matrix $\mathbf{A} = [a_{ij}]$, the **cofactor** A_{ij} of an entry a_{ij} is given by

$$A_{ij} = (-1)^{i+j} M_{ij},$$

where M_{ij} is the minor of a_{ij} .

EXAMPLE 3 For the matrix given in Example 2, find each of the following.

a) A_{11}

b) A_{23}

Solution

a) In Example 2, we found that $M_{11} = -9$. Then

$$A_{11} = (-1)^{1+1}(-9) = (1)(-9) = -9.$$

b) In Example 2, we found that $M_{23} = 24$. Then

$$A_{23} = (-1)^{2+3}(24) = (-1)(24) = -24.$$

 **Now Try Exercise 11.**

Note that minors and cofactors are *numbers*. They are *not matrices*.

Consider the matrix \mathbf{A} given by

$$\mathbf{A} = \begin{bmatrix} a_{11} & a_{12} & a_{13} \\ a_{21} & a_{22} & a_{23} \\ a_{31} & a_{32} & a_{33} \end{bmatrix}.$$

The determinant of the matrix, denoted $|\mathbf{A}|$, can be found by multiplying each element of the first column by its cofactor and adding:

$$|\mathbf{A}| = a_{11}A_{11} + a_{21}A_{21} + a_{31}A_{31}.$$

Because

$$A_{11} = (-1)^{1+1}M_{11} = M_{11},$$

$$A_{21} = (-1)^{2+1}M_{21} = -M_{21},$$

and $A_{31} = (-1)^{3+1}M_{31} = M_{31},$

we can write

$$|\mathbf{A}| = a_{11} \cdot \begin{vmatrix} a_{22} & a_{23} \\ a_{32} & a_{33} \end{vmatrix} - a_{21} \cdot \begin{vmatrix} a_{12} & a_{13} \\ a_{32} & a_{33} \end{vmatrix} + a_{31} \cdot \begin{vmatrix} a_{12} & a_{13} \\ a_{22} & a_{23} \end{vmatrix}.$$

It can be shown that we can determine $|\mathbf{A}|$ by choosing *any* row or column, multiplying each element in that row or column by its cofactor, and adding. This is called *expanding* across a row or down a column. We just expanded down the first column. We now define the determinant of a square matrix of any order.

Determinant of Any Square Matrix

For any square matrix \mathbf{A} of order $n \times n$ ($n > 1$), we define the **determinant** of \mathbf{A} , denoted $|\mathbf{A}|$, as follows. Choose any row or column. Multiply each element in that row or column by its cofactor and add the results. The determinant of a 1×1 matrix is simply the element of the matrix. The value of a determinant will be the same no matter which row or column is chosen.

EXAMPLE 4 Evaluate $|\mathbf{A}|$ by expanding across the third row.

$$\mathbf{A} = \begin{bmatrix} -8 & 0 & 6 \\ 4 & -6 & 7 \\ -1 & -3 & 5 \end{bmatrix}$$

TECHNOLOGY CONNECTION

Determinants can be evaluated on a graphing calculator. After entering a matrix, we select the determinant operation from the MATRIX MATH menu and enter the name of the matrix. The calculator will return the value of the determinant of the matrix. For example, for

$$\mathbf{A} = \begin{bmatrix} 1 & 6 & -1 \\ -3 & -5 & 3 \\ 0 & 4 & 2 \end{bmatrix},$$

we have

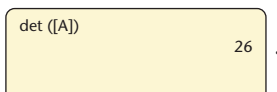

det ([A]) 26

Solution We have

$$\begin{aligned} |\mathbf{A}| &= (-1)A_{31} + (-3)A_{32} + 5A_{33} \\ &= (-1)(-1)^{3+1} \cdot \begin{vmatrix} 0 & 6 \\ -6 & 7 \end{vmatrix} + (-3)(-1)^{3+2} \cdot \begin{vmatrix} -8 & 6 \\ 4 & 7 \end{vmatrix} \\ &\quad + 5(-1)^{3+3} \cdot \begin{vmatrix} -8 & 0 \\ 4 & -6 \end{vmatrix} \\ &= (-1) \cdot 1 \cdot [0 \cdot 7 - (-6)6] + (-3)(-1)[-8 \cdot 7 - 4 \cdot 6] \\ &\quad + 5 \cdot 1 \cdot [-8(-6) - 4 \cdot 0] \\ &= -[36] + 3[-80] + 5[48] \\ &= -36 - 240 + 240 = -36. \end{aligned}$$

The value of this determinant is -36 no matter which row or column we expand on.

 **Now Try Exercise 13.**

► Cramer's Rule

Determinants can be used to solve systems of linear equations. Consider a system of two linear equations:

$$a_1x + b_1y = c_1,$$

$$a_2x + b_2y = c_2.$$

Solving this system using the elimination method, we obtain

$$x = \frac{c_1b_2 - c_2b_1}{a_1b_2 - a_2b_1} \quad \text{and} \quad y = \frac{a_1c_2 - a_2c_1}{a_1b_2 - a_2b_1}.$$

The numerators and the denominators of these expressions can be written as determinants:

$$x = \frac{\begin{vmatrix} c_1 & b_1 \\ c_2 & b_2 \end{vmatrix}}{\begin{vmatrix} a_1 & b_1 \\ a_2 & b_2 \end{vmatrix}} \quad \text{and} \quad y = \frac{\begin{vmatrix} a_1 & c_1 \\ a_2 & c_2 \end{vmatrix}}{\begin{vmatrix} a_1 & b_1 \\ a_2 & b_2 \end{vmatrix}}.$$

If we let

$$D = \begin{vmatrix} a_1 & b_1 \\ a_2 & b_2 \end{vmatrix}, \quad D_x = \begin{vmatrix} c_1 & b_1 \\ c_2 & b_2 \end{vmatrix}, \quad \text{and} \quad D_y = \begin{vmatrix} a_1 & c_1 \\ a_2 & c_2 \end{vmatrix},$$

we have

$$x = \frac{D_x}{D} \quad \text{and} \quad y = \frac{D_y}{D}.$$

This procedure for solving systems of equations is known as *Cramer's rule*.

TECHNOLOGY CONNECTION

To use Cramer's rule to solve the system of equations in Example 5 on a graphing calculator, we first enter the matrices corresponding to D , D_x , and D_y . We enter

$$\mathbf{A} = \begin{bmatrix} 2 & 5 \\ 5 & -2 \end{bmatrix},$$

$$\mathbf{B} = \begin{bmatrix} 7 & 5 \\ -3 & -2 \end{bmatrix},$$

and

$$\mathbf{C} = \begin{bmatrix} 2 & 7 \\ 5 & -3 \end{bmatrix}.$$

Then

$$x = \frac{\det(\mathbf{B})}{\det(\mathbf{A})}$$

and

$$y = \frac{\det(\mathbf{C})}{\det(\mathbf{A})}.$$

```
det ([B])/det([A])
)▶Frac          -1/29
det ([C])/det([A])
)▶Frac          41/29
```

Cramer's Rule for 2×2 Systems

The solution of the system of equations

$$a_1x + b_1y = c_1,$$

$$a_2x + b_2y = c_2$$

is given by

$$x = \frac{D_x}{D}, \quad y = \frac{D_y}{D},$$

where

$$D = \begin{vmatrix} a_1 & b_1 \\ a_2 & b_2 \end{vmatrix}, \quad D_x = \begin{vmatrix} c_1 & b_1 \\ c_2 & b_2 \end{vmatrix},$$

$$D_y = \begin{vmatrix} a_1 & c_1 \\ a_2 & c_2 \end{vmatrix}, \quad \text{and } D \neq 0.$$

Note that the denominator D contains the coefficients of x and y , in the same position as in the original equations. For x , the numerator is obtained by replacing the x -coefficients in D (the a 's) with the c 's. For y , the numerator is obtained by replacing the y -coefficients in D (the b 's) with the c 's.

EXAMPLE 5 Solve using Cramer's rule:

$$2x + 5y = 7,$$

$$5x - 2y = -3.$$

Solution We have

$$x = \frac{\begin{vmatrix} 7 & 5 \\ -3 & -2 \end{vmatrix}}{\begin{vmatrix} 2 & 5 \\ 5 & -2 \end{vmatrix}} = \frac{7(-2) - (-3)5}{2(-2) - 5 \cdot 5} = \frac{1}{-29} = -\frac{1}{29},$$

$$y = \frac{\begin{vmatrix} 2 & 7 \\ 5 & -3 \end{vmatrix}}{\begin{vmatrix} 2 & 5 \\ 5 & -2 \end{vmatrix}} = \frac{2(-3) - 5 \cdot 7}{-29} = \frac{-41}{-29} = \frac{41}{29}.$$

The solution is $\left(-\frac{1}{29}, \frac{41}{29}\right)$.

 **Now Try Exercise 29.**

Cramer's rule works only when a system of equations has a unique solution. This occurs when $D \neq 0$. If $D = 0$ and D_x and D_y are also 0, then the equations are dependent. If $D = 0$ and D_x and/or D_y is not 0, then the system is inconsistent.

Cramer's rule can be extended to a system of n linear equations in n variables. We consider a 3×3 system.

Cramer's Rule for 3×3 Systems

The solution of the system of equations

$$a_1x + b_1y + c_1z = d_1,$$

$$a_2x + b_2y + c_2z = d_2,$$

$$a_3x + b_3y + c_3z = d_3$$

is given by

$$x = \frac{D_x}{D}, \quad y = \frac{D_y}{D}, \quad z = \frac{D_z}{D},$$

where

$$D = \begin{vmatrix} a_1 & b_1 & c_1 \\ a_2 & b_2 & c_2 \\ a_3 & b_3 & c_3 \end{vmatrix}, \quad D_x = \begin{vmatrix} d_1 & b_1 & c_1 \\ d_2 & b_2 & c_2 \\ d_3 & b_3 & c_3 \end{vmatrix},$$

$$D_y = \begin{vmatrix} a_1 & d_1 & c_1 \\ a_2 & d_2 & c_2 \\ a_3 & d_3 & c_3 \end{vmatrix}, \quad D_z = \begin{vmatrix} a_1 & b_1 & d_1 \\ a_2 & b_2 & d_2 \\ a_3 & b_3 & d_3 \end{vmatrix}, \quad \text{and } D \neq 0.$$

Note that the determinant D_x is obtained from D by replacing the x -coefficients with d_1 , d_2 , and d_3 . D_y and D_z are obtained in a similar manner. As with a system of two equations, Cramer's rule cannot be used if $D = 0$. If $D = 0$ and D_x , D_y , and D_z are 0, the equations are dependent. If $D = 0$ and one of D_x , D_y , or D_z is not 0, then the system is inconsistent.

EXAMPLE 6 Solve using Cramer's rule:

$$x - 3y + 7z = 13,$$

$$x + y + z = 1,$$

$$x - 2y + 3z = 4.$$

Solution We have

$$D = \begin{vmatrix} 1 & -3 & 7 \\ 1 & 1 & 1 \\ 1 & -2 & 3 \end{vmatrix} = -10, \quad D_x = \begin{vmatrix} 13 & -3 & 7 \\ 1 & 1 & 1 \\ 4 & -2 & 3 \end{vmatrix} = 20,$$

$$D_y = \begin{vmatrix} 1 & 13 & 7 \\ 1 & 1 & 1 \\ 1 & 4 & 3 \end{vmatrix} = -6, \quad D_z = \begin{vmatrix} 1 & -3 & 13 \\ 1 & 1 & 1 \\ 1 & -2 & 4 \end{vmatrix} = -24.$$

Then

$$x = \frac{D_x}{D} = \frac{20}{-10} = -2, \quad y = \frac{D_y}{D} = \frac{-6}{-10} = \frac{3}{5}, \quad z = \frac{D_z}{D} = \frac{-24}{-10} = \frac{12}{5}.$$

The solution is $\left(-2, \frac{3}{5}, \frac{12}{5}\right)$.

In practice, it is not necessary to evaluate D_z . When we have found values for x and y , we can substitute them into one of the equations to find z .

 **Now Try Exercise 37.**

9.6 Exercise Set

Evaluate the determinant.

1. $\begin{vmatrix} 5 & 3 \\ -2 & -4 \end{vmatrix}$

2. $\begin{vmatrix} -8 & 6 \\ -1 & 2 \end{vmatrix}$

3. $\begin{vmatrix} 4 & -7 \\ -2 & 3 \end{vmatrix}$

4. $\begin{vmatrix} -9 & -6 \\ 5 & 4 \end{vmatrix}$

5. $\begin{vmatrix} -2 & -\sqrt{5} \\ -\sqrt{5} & 3 \end{vmatrix}$

6. $\begin{vmatrix} \sqrt{5} & -3 \\ 4 & 2 \end{vmatrix}$

7. $\begin{vmatrix} x & 4 \\ x & x^2 \end{vmatrix}$

8. $\begin{vmatrix} y^2 & -2 \\ y & 3 \end{vmatrix}$

Use the following matrix for Exercises 9–16:

$$\mathbf{A} = \begin{bmatrix} 7 & -4 & -6 \\ 2 & 0 & -3 \\ 1 & 2 & -5 \end{bmatrix}.$$

9. Find M_{11} , M_{32} , and M_{22} .

10. Find M_{13} , M_{31} , and M_{23} .

11. Find A_{11} , A_{32} , and A_{22} .

12. Find A_{13} , A_{31} , and A_{23} .

13. Evaluate $|\mathbf{A}|$ by expanding across the second row.

14. Evaluate $|\mathbf{A}|$ by expanding down the second column.

15. Evaluate $|\mathbf{A}|$ by expanding down the third column.

16. Evaluate $|\mathbf{A}|$ by expanding across the first row.

Use the following matrix for Exercises 17–22:

$$\mathbf{A} = \begin{bmatrix} 1 & 0 & 0 & -2 \\ 4 & 1 & 0 & 0 \\ 5 & 6 & 7 & 8 \\ -2 & -3 & -1 & 0 \end{bmatrix}.$$

17. Find M_{12} and M_{44} .

18. Find M_{41} and M_{33} .

19. Find A_{22} and A_{34} .

20. Find A_{24} and A_{43} .

21. Evaluate $|\mathbf{A}|$ by expanding across the first row.

22. Evaluate $|\mathbf{A}|$ by expanding down the third column.

Evaluate the determinant.

23. $\begin{vmatrix} 3 & 1 & 2 \\ -2 & 3 & 1 \\ 3 & 4 & -6 \end{vmatrix}$

24. $\begin{vmatrix} 3 & -2 & 1 \\ 2 & 4 & 3 \\ -1 & 5 & 1 \end{vmatrix}$

25. $\begin{vmatrix} x & 0 & -1 \\ 2 & x & x^2 \\ -3 & x & 1 \end{vmatrix}$

26. $\begin{vmatrix} x & 1 & -1 \\ x^2 & x & x \\ 0 & x & 1 \end{vmatrix}$

Solve using Cramer's rule.

$$27. \begin{cases} -2x + 4y = 3, \\ 3x - 7y = 1 \end{cases}$$

$$29. \begin{cases} 2x - y = 5, \\ x - 2y = 1 \end{cases}$$

$$31. \begin{cases} 2x + 9y = -2, \\ 4x - 3y = 3 \end{cases}$$

$$33. \begin{cases} 2x + 5y = 7, \\ 3x - 2y = 1 \end{cases}$$

$$35. \begin{cases} 3x + 2y - z = 4, \\ 3x - 2y + z = 5, \\ 4x - 5y - z = -1 \end{cases}$$

$$36. \begin{cases} 3x - y + 2z = 1, \\ x - y + 2z = 3, \\ -2x + 3y + z = 1 \end{cases}$$

$$37. \begin{cases} 3x + 5y - z = -2, \\ x - 4y + 2z = 13, \\ 2x + 4y + 3z = 1 \end{cases}$$

$$38. \begin{cases} 3x + 2y + 2z = 1, \\ 5x - y - 6z = 3, \\ 2x + 3y + 3z = 4 \end{cases}$$

$$39. \begin{cases} x - 3y - 7z = 6, \\ 2x + 3y + z = 9, \\ 4x + y = 7 \end{cases}$$

$$40. \begin{cases} x - 2y - 3z = 4, \\ 3x - 2z = 8, \\ 2x + y + 4z = 13 \end{cases}$$

$$41. \begin{cases} 6y + 6z = -1, \\ 8x + 6z = -1, \\ 4x + 9y = 8 \end{cases}$$

$$42. \begin{cases} 3x + 5y = 2, \\ 2x - 3z = 7, \\ 4y + 2z = -1 \end{cases}$$

$$28. \begin{cases} 5x - 4y = -3, \\ 7x + 2y = 6 \end{cases}$$

$$30. \begin{cases} 3x + 4y = -2, \\ 5x - 7y = 1 \end{cases}$$

$$32. \begin{cases} 2x + 3y = -1, \\ 3x + 6y = -0.5 \end{cases}$$

$$34. \begin{cases} 3x + 2y = 7, \\ 2x + 3y = -2 \end{cases}$$

Simplify. Write answers in the form $a + bi$, where a and b are real numbers.

$$47. (3 - 4i) - (-2 - i)$$

$$48. (5 + 2i) + (1 - 4i)$$

$$49. (1 - 2i)(6 + 2i)$$

$$50. \frac{3 + i}{4 - 3i}$$

Synthesis

Solve.

$$51. \begin{vmatrix} x & 5 \\ -4 & x \end{vmatrix} = 24$$

$$52. \begin{vmatrix} y & 2 \\ 3 & y \end{vmatrix} = y$$

$$53. \begin{vmatrix} x & -3 \\ -1 & x \end{vmatrix} \geq 0$$

$$54. \begin{vmatrix} y & -5 \\ -2 & y \end{vmatrix} < 0$$

$$55. \begin{vmatrix} x + 3 & 4 \\ x - 3 & 5 \end{vmatrix} = -7$$

$$56. \begin{vmatrix} m + 2 & -3 \\ m + 5 & -4 \end{vmatrix} = 3m - 5$$

$$57. \begin{vmatrix} 2 & x & 1 \\ 1 & 2 & -1 \\ 3 & 4 & -2 \end{vmatrix} = -6$$

$$58. \begin{vmatrix} x & 2 & x \\ 3 & -1 & 1 \\ 1 & -2 & 2 \end{vmatrix} = -10$$

Rewrite the expression using a determinant. Answers may vary.

$$59. 2L + 2W$$

$$61. a^2 + b^2$$

$$63. 2\pi r^2 + 2\pi rh$$

$$60. \pi r + \pi h$$

$$62. \frac{1}{2}h(a + b)$$

$$64. x^2y^2 - Q^2$$

Skill Maintenance

Determine whether the function is one-to-one, and if it is, find a formula for $f^{-1}(x)$.

$$43. f(x) = 3x + 2$$

$$45. f(x) = |x| + 3$$

$$44. f(x) = x^2 - 4$$

$$46. f(x) = \sqrt[3]{x} + 1$$

Systems of Inequalities and Linear Programming

9.7

- ▶ Graph linear inequalities.
- ▶ Graph systems of linear inequalities.
- ▶ Solve linear programming problems.

A graph of an inequality is a drawing that represents its solutions. We have already seen that an inequality in one variable can be graphed on the number line. An inequality in two variables can be graphed on a coordinate plane.

▶ Graphs of Linear Inequalities

A statement like $5x - 4y < 20$ is a linear inequality in two variables.

Linear Inequality in Two Variables

A **linear inequality in two variables** is an inequality that can be written in the form

$$Ax + By < C,$$

where A , B , and C are real numbers and A and B are not both zero. The symbol $<$ may be replaced with \leq , $>$, or \geq .

A solution of a linear inequality in two variables is an ordered pair (x, y) for which the inequality is true. For example, $(1, 3)$ is a solution of $5x - 4y < 20$ because $5 \cdot 1 - 4 \cdot 3 < 20$, or $-7 < 20$, is true. On the other hand, $(2, -6)$ is not a solution of $5x - 4y < 20$ because $5 \cdot 2 - 4 \cdot (-6) \not< 20$, or $34 \not< 20$.

The **solution set** of an inequality is the set of all ordered pairs that make it true. The **graph of an inequality** represents its solution set.

EXAMPLE 1 Graph: $y < x + 3$.

Solution We begin by graphing the **related equation** $y = x + 3$. We use a dashed line because the inequality symbol is $<$. This indicates that the line itself is not in the solution set of the inequality.

Note that the line divides the coordinate plane into two regions called **half-planes**. One of these half-planes satisfies the inequality. Either *all* points in a half-plane are in the solution set of the inequality or *none* is.

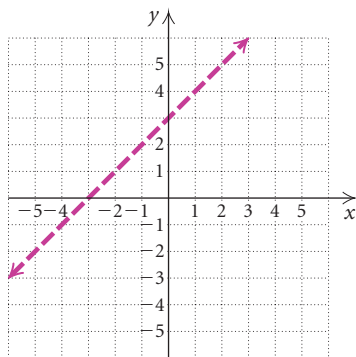

To determine which half-plane satisfies the inequality, we try a test point in either region. The point $(0, 0)$ is usually a convenient choice so long as it does not lie on the line.

$$\begin{array}{r} y < x + 3 \\ 0 \quad ? \quad 0 + 3 \\ 0 \quad | \quad 3 \quad \text{TRUE} \quad 0 < 3 \text{ is true.} \end{array}$$

Since $(0, 0)$ satisfies the inequality, so do all points in the half-plane that contains $(0, 0)$. We shade this region to show the solution set of the inequality.

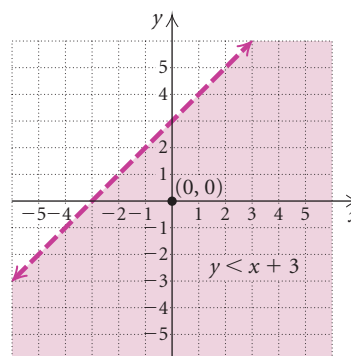

 Now Try Exercise 13.

TECHNOLOGY CONNECTION

One way to graph the inequality in Example 1 on a graphing calculator is to first enter the related equation, $y = x + 3$. Then select the “shade below” graph style. Note that we must keep in mind that the line $y = x + 3$ is not included in the solution set.

Some calculators have an application Inequalz on the APPS menu that can be used to graph an inequality. When this application is used, the inequality $y < x + 3$ is entered directly and the graph of the related equation appears as a dashed line.

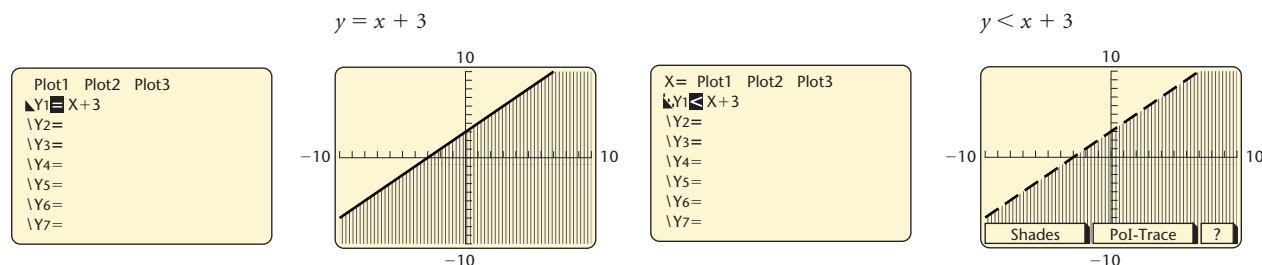

In general, we use the following procedure to graph linear inequalities in two variables by hand.

To graph a linear inequality in two variables:

1. Replace the inequality symbol with an equals sign and graph this related equation. If the inequality symbol is $<$ or $>$, draw the line dashed. If the inequality symbol is \leq or \geq , draw the line solid.
2. The graph consists of a half-plane on one side of the line and, if the line is solid, the line as well. To determine which half-plane to shade, test a point not on the line in the original inequality. If that point is a solution, shade the half-plane containing that point. If not, shade the opposite half-plane.

TECHNOLOGY CONNECTION

To graph the inequality in Example 2 on a graphing calculator, we first solve the related equation for y and enter it in the form $y = \frac{-3x + 12}{4}$. Then we select the “shade above” graph style.

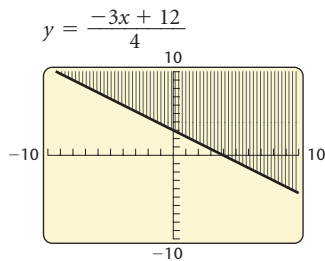

To use the Inequalz application on the APP menu, we solve the inequality for y and enter

$$y \geq \frac{-3x + 12}{4}.$$

EXAMPLE 2 Graph: $3x + 4y \geq 12$.

Solution

1. First, we graph the related equation $3x + 4y = 12$. We use a solid line because the inequality symbol is \geq . This indicates that the line is included in the solution set.
2. To determine which half-plane to shade, we test a point in either region. We choose $(0, 0)$.

$$\begin{array}{r} 3x + 4y \geq 12 \\ 3 \cdot 0 + 4 \cdot 0 \quad ? \quad 12 \\ 0 \quad | \quad 12 \quad \text{FALSE} \quad 0 \geq 12 \text{ is false.} \end{array}$$

Because $(0, 0)$ is *not* a solution, all the points in the half-plane that does *not* contain $(0, 0)$ are solutions. We shade that region, as shown in the figure below.

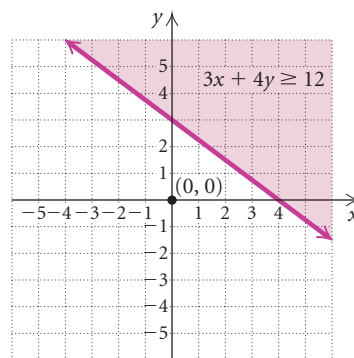

 Now Try Exercise 17.

EXAMPLE 3 Graph $x > -3$ on a plane.**Solution**

1. First, we graph the related equation $x = -3$. We use a dashed line because the inequality symbol is $>$. This indicates that the line is not included in the solution set.
2. The inequality tells us that all points (x, y) for which $x > -3$ are solutions. These are the points to the right of the line. We can also use a test point to determine the solutions. We choose $(5, 1)$.

$$\begin{array}{r} x > -3 \\ 5 \text{ ? } -3 \text{ TRUE} \end{array} \quad 5 > -3 \text{ is true.}$$

Because $(5, 1)$ is a solution, we shade the region containing that point—that is, the region to the right of the dashed line.

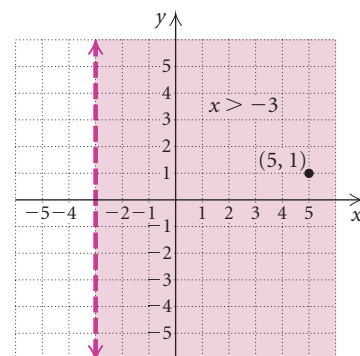

Now Try Exercise 23.

EXAMPLE 4 Graph $y \leq 4$ on a plane.**Solution**

1. First, we graph the related equation $y = 4$. We use a solid line because the inequality symbol is \leq .
2. The inequality tells us that all points (x, y) for which $y \leq 4$ are solutions of the inequality. These are the points on or below the line. We can also use a test point to determine the solutions. We choose $(-2, 5)$.

$$\begin{array}{r} y \leq 4 \\ 5 \text{ ? } 4 \text{ FALSE} \end{array} \quad 5 \leq 4 \text{ is false.}$$

Because $(-2, 5)$ is not a solution, we shade the half-plane that does not contain that point.

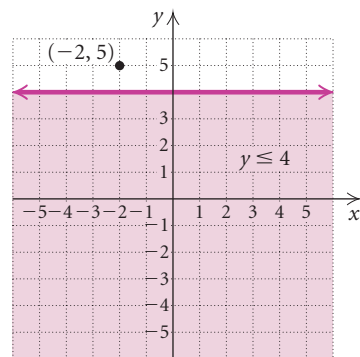

Now Try Exercise 25.

TECHNOLOGY CONNECTION

We can graph inequalities, such as the one in Example 3, on a calculator that has the Inequalz application on the APPS menu.

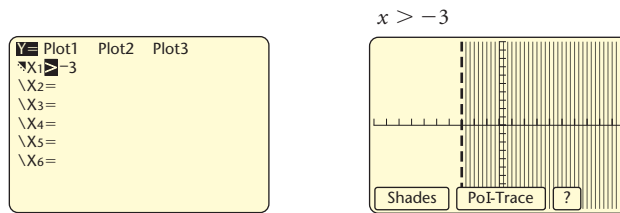

We can graph the inequality $y \leq 4$ in Example 4 using Inequalz or by first graphing $y = 4$ and then using the “shade below” graph style.

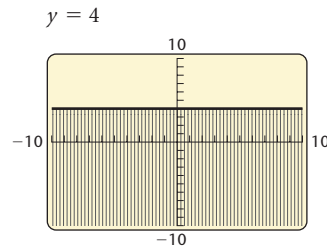

► Systems of Linear Inequalities

A system of inequalities consists of two or more inequalities considered simultaneously. For example,

$$\begin{aligned}x + y &\leq 4, \\x - y &\geq 2\end{aligned}$$

is a system of *two linear inequalities in two variables*.

A solution of a system of inequalities is an ordered pair that is a solution of each inequality in the system. To graph a system of linear inequalities, we graph each inequality and determine the region that is common to *all* the solution sets.

EXAMPLE 5 Graph the solution set of the system

$$\begin{aligned}x + y &\leq 4, \\x - y &\geq 2.\end{aligned}$$

TECHNOLOGY CONNECTION

We can use different shading patterns on a graphing calculator to graph the system of inequalities in Example 5. The solution set is the region shaded using both patterns.

$$y_1 = 4 - x, \quad y_2 = x - 2$$

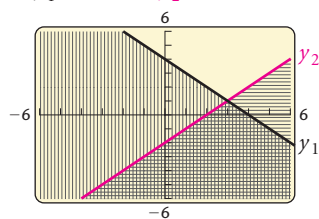

We can also use the Inequalz application to graph this system of inequalities. If we choose the Ineq Intersection option from the Shades menu, only the solution set is shaded, as shown in the figure below.

$$y_1 \leq 4 - x, \quad y_2 \leq x - 2$$

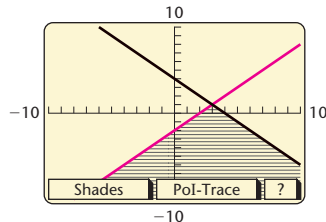

Solution We graph $x + y \leq 4$ by first graphing the equation $x + y = 4$ using a solid line. Next, we choose $(0, 0)$ as a test point and find that it is a solution of $x + y \leq 4$, so we shade the half-plane containing $(0, 0)$ using red. Next, we graph $x - y = 2$ using a solid line. We find that $(0, 0)$ is not a solution of $x - y \geq 2$, so we shade the half-plane that does not contain $(0, 0)$ using green. The arrows near the ends of each line help to indicate the half-plane that contains each solution set.

The solution set of the system of equations is the region shaded both red and green, or brown, including parts of the lines $x + y = 4$ and $x - y = 2$.

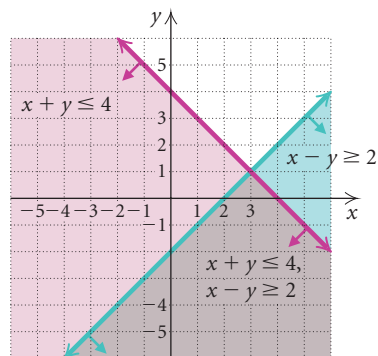

A system of inequalities may have a graph that consists of a polygon and its interior. As we will see later in this section, in many applications we will need to know the vertices of such a polygon.

EXAMPLE 6 Graph the following system of inequalities and find the coordinates of any vertices formed:

$$3x - y \leq 6, \quad (1)$$

$$y - 3 \leq 0, \quad (2)$$

$$x + y \geq 0. \quad (3)$$

Solution We graph the related equations $3x - y = 6$, $y - 3 = 0$, and $x + y = 0$ using solid lines. The half-plane containing the solution set for each inequality is indicated by the arrows near the ends of each line. We shade the region common to all three solution sets.

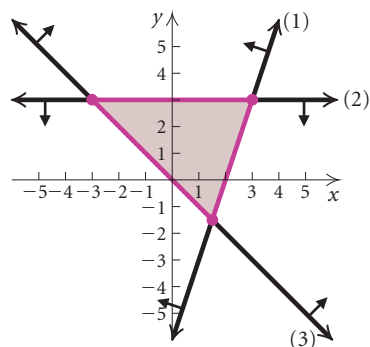

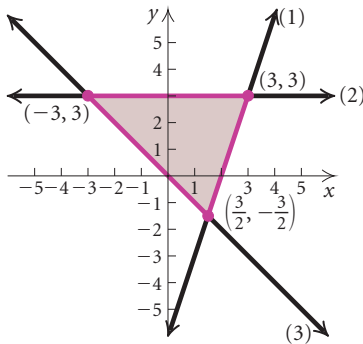

To find the vertices, we solve three systems of equations. The system of equations from inequalities (1) and (2) is

$$\begin{aligned} 3x - y &= 6, \\ y - 3 &= 0. \end{aligned}$$

Solving, we obtain the vertex $(3, 3)$.

The system of equations from inequalities (1) and (3) is

$$\begin{aligned} 3x - y &= 6, \\ x + y &= 0. \end{aligned}$$

Solving, we obtain the vertex $(\frac{3}{2}, -\frac{3}{2})$.

The system of equations from inequalities (2) and (3) is

$$\begin{aligned} y - 3 &= 0, \\ x + y &= 0. \end{aligned}$$

Solving, we obtain the vertex $(-3, 3)$.

 **Now Try Exercise 55.**

► Applications: Linear Programming

In many applications, we want to find a maximum value or a minimum value. In business, for example, we might want to maximize profit and minimize cost. **Linear programming** can tell us how to do this.

In our study of linear programming, we will consider linear functions of two variables that are to be maximized or minimized subject to several conditions, or **constraints**. These constraints are expressed as inequalities. The solution set of the system of inequalities made up of the constraints contains all the **feasible solutions** of a linear programming problem. The function that we want to maximize or minimize is called the **objective function**.

It can be shown that the maximum and minimum values of the objective function occur at a vertex of the region of feasible solutions. Thus we have the following procedure.

Linear Programming Procedure

To find the maximum or minimum value of a linear objective function subject to a set of constraints:

1. Graph the region of feasible solutions.
2. Determine the coordinates of the vertices of the region.
3. Evaluate the objective function at each vertex. The largest and smallest of those values are the maximum and minimum values of the function, respectively.



EXAMPLE 7 Maximizing Profit. Dovetail Carpentry Shop makes bookcases and desks. Each bookcase requires 5 hr of woodworking and 4 hr of finishing. Each desk requires 10 hr of woodworking and 3 hr of finishing. Each month the shop has 600 hr of labor available for woodworking and 240 hr for finishing. The profit on each bookcase is \$40 and on each desk is \$75. How many of each product should be made each month in order to maximize profit?

Solution We let x = the number of bookcases to be produced and y = the number of desks. Then the profit P is given by the function

$$P = 40x + 75y. \quad \text{To emphasize that } P \text{ is a function of two variables, we sometimes write } P(x, y) = 40x + 75y.$$

We know that x bookcases require $5x$ hr of woodworking and y desks require $10y$ hr of woodworking. Since there is no more than 600 hr of labor available for woodworking, we have one constraint:

$$5x + 10y \leq 600.$$

Similarly, the bookcases and the desks require $4x$ hr and $3y$ hr of finishing, respectively. There is no more than 240 hr of labor available for finishing, so we have a second constraint:

$$4x + 3y \leq 240.$$

We also know that $x \geq 0$ and $y \geq 0$ because the carpentry shop cannot make a negative number of either product.

Thus we want to maximize the objective function

$$P = 40x + 75y$$

subject to the constraints

$$5x + 10y \leq 600,$$

$$4x + 3y \leq 240,$$

$$x \geq 0,$$

$$y \geq 0.$$

We graph the system of inequalities and determine the vertices.

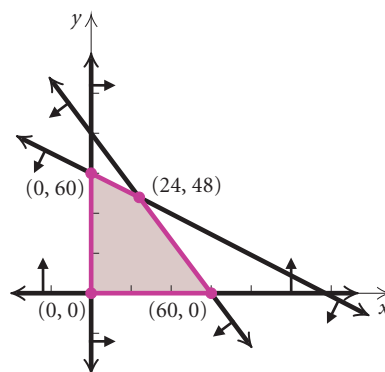

TECHNOLOGY CONNECTION

We can create a table in which an objective function is evaluated at each vertex of a system of inequalities if the system has been graphed using the Inequalz application in the APPS menu. Refer to the online *Graphing Calculator Manual* that accompanies the text for details.

Next, we evaluate the objective function P at each vertex.

Vertices (x, y)	Profit $P = 40x + 75y$
(0, 0)	$P = 40 \cdot 0 + 75 \cdot 0 = 0$
(60, 0)	$P = 40 \cdot 60 + 75 \cdot 0 = 2400$
(24, 48)	$P = 40 \cdot 24 + 75 \cdot 48 = 4560$
(0, 60)	$P = 40 \cdot 0 + 75 \cdot 60 = 4500$

← Maximum

The carpentry shop will make a maximum profit of \$4560 when 24 bookcases and 48 desks are produced and sold.

➔ Now Try Exercise 65.

9.7

Exercise Set

In Exercises 1–8, match the inequality with one of the graphs (a)–(h), which follow.

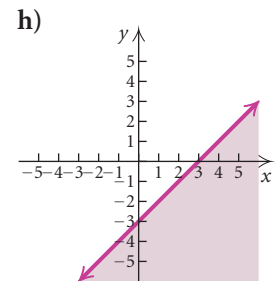
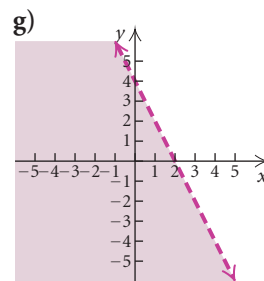
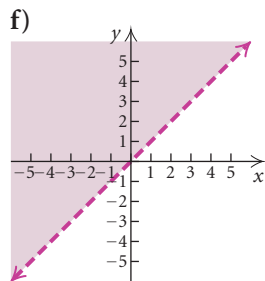
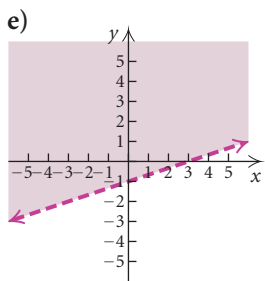
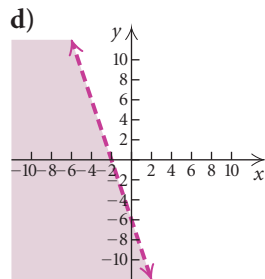
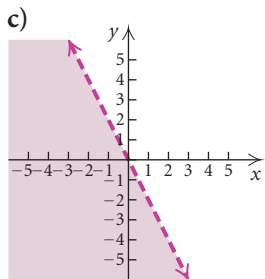
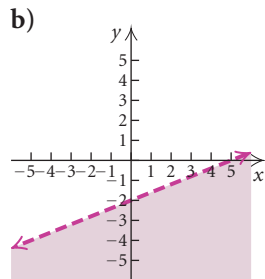
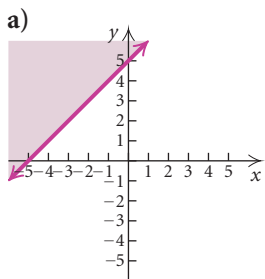

- $y > x$
- $y \leq x - 3$
- $2x + y < 4$
- $2x - 5y > 10$

Graph.

- $y > 2x$
- $y + x \geq 0$
- $y > x - 3$
- $x + y < 4$
- $3x - 2y \leq 6$
- $3y + 2x \geq 6$
- $3x - 2 \leq 5x + y$
- $x < -4$
- $y \geq 5$

- $y < -2x$
- $y \geq x + 5$
- $3x + y < -6$
- $3x - 9y < 9$
- $2y < x$
- $y - x < 0$
- $y \leq x + 4$
- $x - y \geq 5$
- $2x - 5y < 10$
- $2y + x \leq 4$
- $2x - 6y \geq 8 + 2y$
- $y > -3$
- $x \leq 5$

27. $-4 < y < -1$

(Hint: Think of this as $-4 < y$ and $y < -1$.)

28. $-3 \leq x \leq 3$

(Hint: Think of this as $-3 \leq x$ and $x \leq 3$.)

29. $y \geq |x|$

30. $y \leq |x + 2|$

In Exercises 31–36, match the system of inequalities with one of the graphs (a)–(f), which follow.

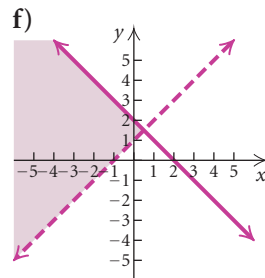
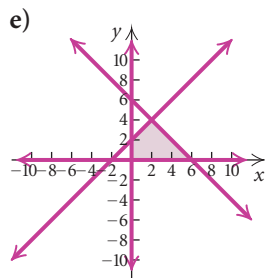
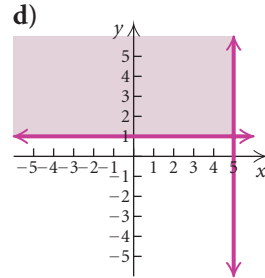
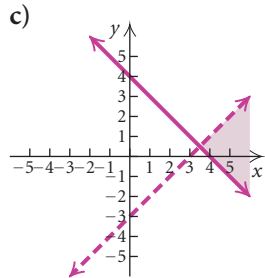
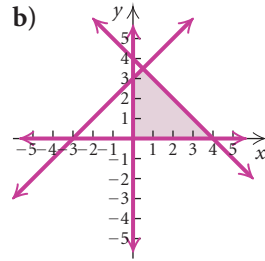
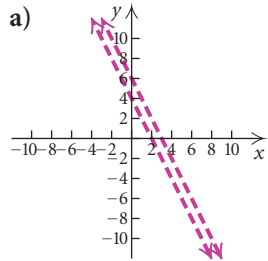

31. $y > x + 1,$
 $y \leq 2 - x$

33. $2x + y < 4,$
 $4x + 2y > 12$

35. $x + y \leq 4,$
 $x - y \geq -3,$
 $x \geq 0,$
 $y \geq 0$

32. $y < x - 3,$
 $y \geq 4 - x$

34. $x \leq 5,$
 $y \geq 1$

36. $x - y \geq -2,$
 $x + y \leq 6,$
 $x \geq 0,$
 $y \geq 0$

Find a system of inequalities with the given graph. Answers may vary.

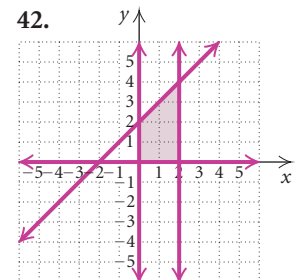
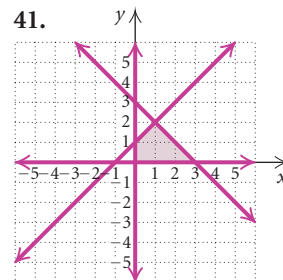
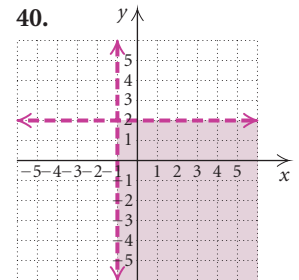
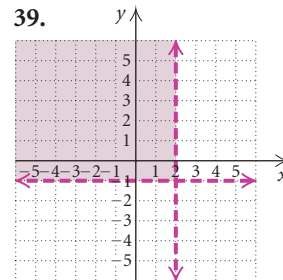
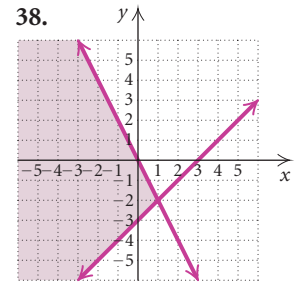
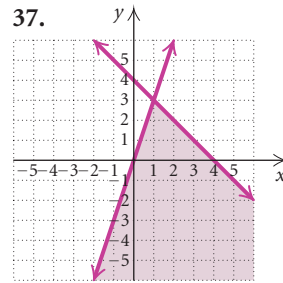

Graph the system of inequalities. Then find the coordinates of the vertices.

43. $y \leq x,$
 $y \geq 3 - x$

45. $y \geq x,$
 $y \leq 4 - x$

47. $y \geq -3,$
 $x \geq 1$

49. $x \leq 3,$
 $y \geq 2 - 3x$

51. $x + y \leq 1,$
 $x - y \leq 2$

44. $y \leq x,$
 $y \geq 5 - x$

46. $y \geq x,$
 $y \leq 2 - x$

48. $y \leq -2,$
 $x \geq 2$

50. $x \geq -2,$
 $y \leq 3 - 2x$

52. $y + 3x \geq 0,$
 $y + 3x \leq 2$

53. $2y - x \leq 2,$
 $y + 3x \geq -1$
54. $y \leq 2x + 1,$
 $y \geq -2x + 1,$
 $x - 2 \leq 0$
55. $x - y \leq 2,$
 $x + 2y \geq 8,$
 $y - 4 \leq 0$
56. $x + 2y \leq 12,$
 $2x + y \leq 12,$
 $x \geq 0,$
 $y \geq 0$
57. $4y - 3x \geq -12,$
 $4y + 3x \geq -36,$
 $y \leq 0,$
 $x \leq 0$
58. $8x + 5y \leq 40,$
 $x + 2y \leq 8,$
 $x \geq 0,$
 $y \geq 0$
59. $3x + 4y \geq 12,$
 $5x + 6y \leq 30,$
 $1 \leq x \leq 3$
60. $y - x \geq 1,$
 $y - x \leq 3,$
 $2 \leq x \leq 5$

Find the maximum value and the minimum value of the function and the values of x and y for which they occur.

61. $P = 17x - 3y + 60$, subject to
 $6x + 8y \leq 48,$
 $0 \leq y \leq 4,$
 $0 \leq x \leq 7.$
62. $Q = 28x - 4y + 72$, subject to
 $5x + 4y \geq 20,$
 $0 \leq y \leq 4,$
 $0 \leq x \leq 3.$
63. $F = 5x + 36y$, subject to
 $5x + 3y \leq 34,$
 $3x + 5y \leq 30,$
 $x \geq 0,$
 $y \geq 0.$
64. $G = 16x + 14y$, subject to
 $3x + 2y \leq 12,$
 $7x + 5y \leq 29,$
 $x \geq 0,$
 $y \geq 0.$
65. **Maximizing Income.** Golden Harvest Foods makes jumbo biscuits and regular biscuits. The oven can cook at most 200 biscuits per day. Each jumbo biscuit requires 2 oz of flour, each regular biscuit requires 1 oz of flour, and there are 300 oz of flour available. The income from each jumbo biscuit is \$0.10 and from each regular biscuit is \$0.08. How many of each size biscuit should be made in order to maximize income? What is the maximum income?
66. **Maximizing Mileage.** Omar owns a pickup truck and a moped. He can afford 12 gal of gasoline to be split between the truck and the moped. Omar's

truck gets 20 mpg and, with the fuel currently in the tank, can hold at most an additional 10 gal of gas. His moped gets 100 mpg and can hold at most 3 gal of gas. How many gallons of gasoline should each vehicle use if Omar wants to travel as far as possible on the 12 gal of gas? What is the maximum number of miles that he can travel?



67. **Maximizing Profit.** Norris Mill can convert logs into lumber and plywood. In a given week, the mill can turn out 400 units of production, of which 100 units of lumber and 150 units of plywood are required by regular customers. The profit is \$20 per unit of lumber and \$30 per unit of plywood. How many units of each should the mill produce in order to maximize the profit?
68. **Maximizing Profit.** Sunnysdale Farm includes 240 acres of cropland. The farm owner wishes to plant this acreage in corn and oats. The profit per acre in corn production is \$40 and in oats is \$30. A total of 320 hr of labor is available. Each acre of corn requires 2 hr of labor, whereas each acre of oats requires 1 hr of labor. How should the land be divided between corn and oats in order to yield the maximum profit? What is the maximum profit?
69. **Minimizing Cost.** An animal feed to be mixed from soybean meal and oats must contain at least 120 lb of protein, 24 lb of fat, and 10 lb of mineral ash. Each 100-lb sack of soybean meal costs \$15 and contains 50 lb of protein, 8 lb of fat, and 5 lb of mineral ash. Each 100-lb sack of oats costs \$5 and contains 15 lb of protein, 5 lb of fat, and 1 lb of mineral ash. How many sacks of each should be used to satisfy the minimum requirements at minimum cost?
70. **Minimizing Cost.** Suppose that in the preceding problem the oats were replaced by alfalfa, which costs \$8 per 100 lb and contains 20 lb of protein, 6 lb of fat, and 8 lb of mineral ash. How much of each is now required in order to minimize the cost?

71. **Maximizing Income.** Clayton is planning to invest up to \$40,000 in corporate and municipal bonds. The least he is allowed to invest in corporate bonds is \$6000, and he does not want to invest more than \$22,000 in corporate bonds. He also does not want to invest more than \$30,000 in municipal bonds. The interest is 8% on corporate bonds and $7\frac{1}{2}\%$ on municipal bonds. This is simple interest for one year. How much should he invest in each type of bond in order to maximize his income? What is the maximum income?

72. **Maximizing Income.** Margaret is planning to invest up to \$22,000 in certificates of deposit at City Bank and People's Bank. She wants to invest at least \$2000 but no more than \$14,000 at City Bank. People's Bank does not insure more than a \$15,000 investment, so she will invest no more than that in People's Bank. The interest is 6% at City Bank and $6\frac{1}{2}\%$ at People's Bank. This is simple interest for one year. How much should she invest in each bank in order to maximize her income? What is the maximum income?

73. **Minimizing Transportation Cost.** An airline with two types of airplanes, P_1 and P_2 , has contracted with a tour group to provide transportation for a minimum of 2000 first-class, 1500 tourist-class, and 2400 economy-class passengers. For a certain trip, airplane P_1 costs \$12 thousand to operate and can accommodate 40 first-class, 40 tourist-class, and 120 economy-class passengers, whereas airplane P_2 costs \$10 thousand to operate and can accommodate 80 first-class, 30 tourist-class, and 40 economy-class passengers. How many of each type of airplane should be used in order to minimize the operating cost?

74. **Minimizing Transportation Cost.** Suppose that in the preceding problem a new airplane P_3 becomes available, having an operating cost for the same trip of \$15 thousand and accommodating 40 first-class, 40 tourist-class, and 80 economy-class passengers. If airplane P_1 were replaced by airplane P_3 , how many of P_2 and P_3 should be used in order to minimize the operating cost?

75. **Maximizing Profit.** It takes Just Sew 2 hr of cutting and 4 hr of sewing to make a knit suit. It takes 4 hr of cutting and 2 hr of sewing to make a worsted suit. At most 20 hr per day are available for cutting and at most 16 hr per day are available for sewing. The profit is \$34 on a knit suit and \$31 on a worsted suit. How many of each kind of suit should be made each day in order to maximize profit? What is the maximum profit?



76. **Maximizing Profit.** Cambridge Metal Works manufactures two sizes of gears. The smaller gear requires 4 hr of machining and 1 hr of polishing and yields a profit of \$25. The larger gear requires 1 hr of machining and 1 hr of polishing and yields a profit of \$10. The firm has available at most 24 hr per day for machining and 9 hr per day for polishing. How many of each type of gear should be produced each day in order to maximize profit? What is the maximum profit?

77. **Minimizing Nutrition Cost.** Suppose that it takes 12 units of carbohydrates and 6 units of protein to satisfy Jacob's minimum weekly requirements. A particular type of meat contains 2 units of carbohydrates and 2 units of protein per pound. A particular cheese contains 3 units of carbohydrates and 1 unit of protein per pound. The meat costs \$3.50 per pound and the cheese costs \$4.60 per pound. How many pounds of each are needed in order to minimize the cost and still meet the minimum requirements?

78. **Minimizing Salary Cost.** The Spring Hill school board is analyzing education costs for Hill Top School. It wants to hire teachers and teacher's aides to make up a faculty that satisfies its needs at minimum cost. The average annual salary for a teacher is \$35,000 and for a teacher's aide is \$18,000. The school building can accommodate a faculty of no more than 50 but needs at least 20 faculty members to function properly. The school must have at least 12 aides, but the number of teachers must be at least twice the number of aides in order to accommodate the expectations of the community. How many teachers and teacher's aides should be hired in order to minimize salary costs?
79. **Maximizing Animal Support in a Forest.** A certain area of forest is populated by two species of animal, which scientists refer to as A and B for simplicity. The forest supplies two kinds of food, referred to as F_1 and F_2 . For one year, each member of species A requires 1 unit of F_1 and 0.5 unit of F_2 . Each member of species B requires 0.2 unit of F_1 and 1 unit of F_2 . The forest can normally supply at most 600 units of F_1 and 525 units of F_2 per year. What is the maximum total number of these animals that the forest can support?



80. **Maximizing Animal Support in a Forest.** Refer to Exercise 79. If there is a wet spring, then supplies of food increase to 1080 units of F_1 and 810 units of F_2 . In this case, what is the maximum total number of these animals that the forest can support?

Skill Maintenance

Solve.

81. $-5 \leq x + 2 < 4$ 82. $|x - 3| \geq 2$
83. $x^2 - 2x \leq 3$ 84. $\frac{x - 1}{x + 2} > 4$

Synthesis

Graph the system of inequalities.

85. $y \geq x^2 - 2,$
 $y \leq 2 - x^2$ 86. $y < x + 1,$
 $y \geq x^2$

Graph the inequality.

87. $|x + y| \leq 1$
88. $|x| + |y| \leq 1$
89. $|x| > |y|$
90. $|x - y| > 0$

91. **Allocation of Resources.** Significant Sounds manufactures two types of speaker assemblies. The less expensive assembly, which sells for \$350, consists of one midrange speaker and one tweeter. The more expensive speaker assembly, which sells for \$600, consists of one woofer, one midrange speaker, and two tweeters. The manufacturer has in stock 44 woofers, 60 midrange speakers, and 90 tweeters. How many of each type of speaker assembly should be made in order to maximize income? What is the maximum income?
92. **Allocation of Resources.** Sitting Pretty Furniture produces chairs and sofas. Each chair requires 20 ft of wood, 1 lb of foam rubber, and 2 yd² of fabric. Each sofa requires 100 ft of wood, 50 lb of foam rubber, and 20 yd² of fabric. The manufacturer has in stock 1900 ft of wood, 500 lb of foam rubber, and 240 yd² of fabric. The chairs can be sold for \$80 each and the sofas for \$300 each. How many of each should be produced in order to maximize income? What is the maximum income?

Partial Fractions

9.8

- Decompose rational expressions into partial fractions.

There are situations in calculus in which it is useful to write a rational expression as a sum of two or more simpler rational expressions. In the equation

$$\frac{4x - 13}{2x^2 + x - 6} = \frac{3}{x + 2} + \frac{-2}{2x - 3},$$

each fraction on the right side is called a **partial fraction**. The expression on the right side is the **partial fraction decomposition** of the rational expression on the left side. In this section, we learn how such decompositions are created.

► Partial Fraction Decompositions

The procedure for finding the partial fraction decomposition of a rational expression involves factoring its denominator into linear and quadratic factors.

Procedure for Decomposing a Rational Expression into Partial Fractions

Consider any rational expression $P(x)/Q(x)$ such that $P(x)$ and $Q(x)$ have no common factor other than 1 or -1 .

1. If the degree of $P(x)$ is greater than or equal to the degree of $Q(x)$, divide to express $P(x)/Q(x)$ as a quotient + remainder/ $Q(x)$ and follow steps (2)–(5) to decompose the resulting rational expression.
2. If the degree of $P(x)$ is less than the degree of $Q(x)$, factor $Q(x)$ into linear factors of the form $(px + q)^n$ and/or quadratic factors of the form $(ax^2 + bx + c)^m$. Any quadratic factor $ax^2 + bx + c$ must be *irreducible*, meaning that it cannot be factored into linear factors with rational coefficients.
3. Assign to each linear factor $(px + q)^n$ the sum of n partial fractions:

$$\frac{A_1}{px + q} + \frac{A_2}{(px + q)^2} + \cdots + \frac{A_n}{(px + q)^n}$$

4. Assign to each quadratic factor $(ax^2 + bx + c)^m$ the sum of m partial fractions:

$$\frac{B_1x + C_1}{ax^2 + bx + c} + \frac{B_2x + C_2}{(ax^2 + bx + c)^2} + \cdots + \frac{B_mx + C_m}{(ax^2 + bx + c)^m}$$

5. Apply algebraic methods, as illustrated in the following examples, to find the constants in the numerators of the partial fractions.

TECHNOLOGY CONNECTION

We can use the TABLE feature on a graphing calculator to check a partial fraction decomposition. To check the decomposition in Example 1, we compare values of

$$y_1 = \frac{4x - 13}{2x^2 + x - 6}$$

and

$$y_2 = \frac{3}{x + 2} - \frac{2}{2x - 3}$$

for the same values of x . Since $y_1 = y_2$ for the given values of x as we scroll through the table, the decomposition appears to be correct.

X	Y1	Y2
-1	3.4	3.4
0	2.1667	2.1667
1	3	3
2	-1.25	-1.25
3	-.0667	-.0667
4	.1	.1
5	.14286	.14286

X = -1

EXAMPLE 1 Decompose into partial fractions:

$$\frac{4x - 13}{2x^2 + x - 6}$$

Solution The degree of the numerator is less than the degree of the denominator. We begin by factoring the denominator: $(x + 2)(2x - 3)$. We find constants A and B such that

$$\frac{4x - 13}{(x + 2)(2x - 3)} = \frac{A}{x + 2} + \frac{B}{2x - 3}$$

To determine A and B , we add the expressions on the right:

$$\frac{4x - 13}{(x + 2)(2x - 3)} = \frac{A(2x - 3) + B(x + 2)}{(x + 2)(2x - 3)}$$

Next, we equate the numerators:

$$4x - 13 = A(2x - 3) + B(x + 2)$$

Since the last equation containing A and B is true for all x , we can substitute any value of x and still have a true equation. If we choose $x = \frac{3}{2}$, then $2x - 3 = 0$ and A will be eliminated when we make the substitution. This gives us

$$\begin{aligned} 4\left(\frac{3}{2}\right) - 13 &= A\left(2 \cdot \frac{3}{2} - 3\right) + B\left(\frac{3}{2} + 2\right) \\ -7 &= 0 + \frac{7}{2}B. \end{aligned}$$

Solving, we obtain $B = -2$.

If we choose $x = -2$, then $x + 2 = 0$ and B will be eliminated when we make the substitution. This gives us

$$\begin{aligned} 4(-2) - 13 &= A[2(-2) - 3] + B(-2 + 2) \\ -21 &= -7A + 0. \end{aligned}$$

Solving, we obtain $A = 3$.

The decomposition is as follows:

$$\frac{4x - 13}{2x^2 + x - 6} = \frac{3}{x + 2} + \frac{-2}{2x - 3}, \quad \text{or} \quad \frac{3}{x + 2} - \frac{2}{2x - 3}$$

To check, we can add to see if we get the expression on the left.

 **Now Try Exercise 3.**

EXAMPLE 2 Decompose into partial fractions:

$$\frac{7x^2 - 29x + 24}{(2x - 1)(x - 2)^2}$$

Solution The degree of the numerator is 2 and the degree of the denominator is 3, so the degree of the numerator is less than the degree of the denominator. The denominator is given in factored form. The decomposition has the following form:

$$\frac{7x^2 - 29x + 24}{(2x - 1)(x - 2)^2} = \frac{A}{2x - 1} + \frac{B}{x - 2} + \frac{C}{(x - 2)^2}$$

As in Example 1, we add the expressions on the right:

$$\frac{7x^2 - 29x + 24}{(2x - 1)(x - 2)^2} = \frac{A(x - 2)^2 + B(2x - 1)(x - 2) + C(2x - 1)}{(2x - 1)(x - 2)^2}.$$

Then we equate the numerators. This gives us

$$7x^2 - 29x + 24 = A(x - 2)^2 + B(2x - 1)(x - 2) + C(2x - 1).$$

Since the equation containing A , B , and C is true for all x , we can substitute any value of x and still have a true equation. In order to have $2x - 1 = 0$, we let $x = \frac{1}{2}$. This gives us

$$\begin{aligned} 7\left(\frac{1}{2}\right)^2 - 29 \cdot \frac{1}{2} + 24 &= A\left(\frac{1}{2} - 2\right)^2 + 0 + 0 \\ \frac{45}{4} &= \frac{9}{4}A. \end{aligned}$$

Solving, we obtain $A = 5$.

In order to have $x - 2 = 0$, we let $x = 2$. Substituting gives us

$$\begin{aligned} 7(2)^2 - 29(2) + 24 &= 0 + 0 + C(2 \cdot 2 - 1) \\ -6 &= 3C. \end{aligned}$$

Solving, we obtain $C = -2$.

To find B , we choose any value for x except $\frac{1}{2}$ or 2 and replace A with 5 and C with -2 . We let $x = 1$:

$$\begin{aligned} 7 \cdot 1^2 - 29 \cdot 1 + 24 &= 5(1 - 2)^2 + B(2 \cdot 1 - 1)(1 - 2) \\ &\quad + (-2)(2 \cdot 1 - 1) \\ 2 &= 5 - B - 2 \\ B &= 1. \end{aligned}$$

The decomposition is as follows:

$$\frac{7x^2 - 29x + 24}{(2x - 1)(x - 2)^2} = \frac{5}{2x - 1} + \frac{1}{x - 2} - \frac{2}{(x - 2)^2}.$$

 **Now Try Exercise 7.**

EXAMPLE 3 Decompose into partial fractions:

$$\frac{6x^3 + 5x^2 - 7}{3x^2 - 2x - 1}.$$

Solution The degree of the numerator is greater than that of the denominator. Thus we divide and find an equivalent expression:

$$\begin{array}{r} 2x + 3 \\ 3x^2 - 2x - 1 \overline{) 6x^3 + 5x^2 - 7} \\ \underline{6x^3 - 4x^2 - 2x} \\ 9x^2 + 2x - 7 \\ \underline{9x^2 - 6x - 3} \\ 8x - 4 \end{array}$$

The original expression is thus equivalent to

$$2x + 3 + \frac{8x - 4}{3x^2 - 2x - 1}.$$

We decompose the fraction to get

$$\frac{8x - 4}{(3x + 1)(x - 1)} = \frac{5}{3x + 1} + \frac{1}{x - 1}.$$

The final result is

$$2x + 3 + \frac{5}{3x + 1} + \frac{1}{x - 1}.$$

 **Now Try Exercise 17.**

Systems of equations can also be used to decompose rational expressions. Let's reconsider Example 2.

EXAMPLE 4 Decompose into partial fractions:

$$\frac{7x^2 - 29x + 24}{(2x - 1)(x - 2)^2}.$$

Solution The decomposition has the following form:

$$\frac{A}{2x - 1} + \frac{B}{x - 2} + \frac{C}{(x - 2)^2}.$$

We first add as in Example 2:

$$\begin{aligned} \frac{7x^2 - 29x + 24}{(2x - 1)(x - 2)^2} &= \frac{A}{2x - 1} + \frac{B}{x - 2} + \frac{C}{(x - 2)^2} \\ &= \frac{A(x - 2)^2 + B(2x - 1)(x - 2) + C(2x - 1)}{(2x - 1)(x - 2)^2}. \end{aligned}$$

Then we equate numerators:

$$\begin{aligned} 7x^2 - 29x + 24 &= A(x - 2)^2 + B(2x - 1)(x - 2) + C(2x - 1) \\ &= A(x^2 - 4x + 4) + B(2x^2 - 5x + 2) + C(2x - 1) \\ &= Ax^2 - 4Ax + 4A + 2Bx^2 - 5Bx + 2B + 2Cx - C, \end{aligned}$$

or, combining like terms,

$$\begin{aligned} 7x^2 - 29x + 24 &= (A + 2B)x^2 + (-4A - 5B + 2C)x + (4A + 2B - C). \end{aligned}$$

Next, we equate corresponding coefficients:

$$\begin{aligned} 7 &= A + 2B, & \text{The coefficients of the } x^2\text{-terms must} \\ & & \text{be the same.} \\ -29 &= -4A - 5B + 2C, & \text{The coefficients of the } x\text{-terms must} \\ & & \text{be the same.} \\ 24 &= 4A + 2B - C. & \text{The constant terms must be the same.} \end{aligned}$$

We now have a system of three equations. You should confirm that the solution of the system is

$$A = 5, \quad B = 1, \quad \text{and} \quad C = -2.$$

The decomposition is as follows:

$$\frac{7x^2 - 29x + 24}{(2x - 1)(x - 2)^2} = \frac{5}{2x - 1} + \frac{1}{x - 2} - \frac{2}{(x - 2)^2}.$$

 **Now Try Exercise 15.**

STUDY TIP

The review icons in the text margins provide references to earlier sections in which you can find content related to the concept at hand. Reviewing this earlier content will add to your understanding of the current concept.

SYSTEMS OF EQUATIONS
IN THREE VARIABLES

REVIEW SECTION 9.2, 9.5, OR 9.6

EXAMPLE 5 Decompose into partial fractions:

$$\frac{11x^2 - 8x - 7}{(2x^2 - 1)(x - 3)}.$$

Solution The decomposition has the following form:

$$\frac{11x^2 - 8x - 7}{(2x^2 - 1)(x - 3)} = \frac{Ax + B}{2x^2 - 1} + \frac{C}{x - 3}.$$

Adding and equating numerators, we get

$$\begin{aligned} 11x^2 - 8x - 7 &= (Ax + B)(x - 3) + C(2x^2 - 1) \\ &= Ax^2 - 3Ax + Bx - 3B + 2Cx^2 - C, \end{aligned}$$

$$\text{or } 11x^2 - 8x - 7 = (A + 2C)x^2 + (-3A + B)x + (-3B - C).$$

We then equate corresponding coefficients:

$$11 = A + 2C, \quad \text{The coefficients of the } x^2\text{-terms}$$

$$-8 = -3A + B, \quad \text{The coefficients of the } x\text{-terms}$$

$$-7 = -3B - C. \quad \text{The constant terms}$$

We solve this system of three equations and obtain

$$A = 3, \quad B = 1, \quad \text{and} \quad C = 4.$$

The decomposition is as follows:

$$\frac{11x^2 - 8x - 7}{(2x^2 - 1)(x - 3)} = \frac{3x + 1}{2x^2 - 1} + \frac{4}{x - 3}.$$

 **Now Try Exercise 13.**

9.8 Exercise Set

Decompose into partial fractions.

1. $\frac{x + 7}{(x - 3)(x + 2)}$

2. $\frac{2x}{(x + 1)(x - 1)}$

3. $\frac{7x - 1}{6x^2 - 5x + 1}$

4. $\frac{13x + 46}{12x^2 - 11x - 15}$

5. $\frac{3x^2 - 11x - 26}{(x^2 - 4)(x + 1)}$

6. $\frac{5x^2 + 9x - 56}{(x - 4)(x - 2)(x + 1)}$

7. $\frac{9}{(x + 2)^2(x - 1)}$

8. $\frac{x^2 - x - 4}{(x - 2)^3}$

9. $\frac{2x^2 + 3x + 1}{(x^2 - 1)(2x - 1)}$

10. $\frac{x^2 - 10x + 13}{(x^2 - 5x + 6)(x - 1)}$

11. $\frac{x^4 - 3x^3 - 3x^2 + 10}{(x + 1)^2(x - 3)}$

12. $\frac{10x^3 - 15x^2 - 35x}{x^2 - x - 6}$

13.
$$\frac{-x^2 + 2x - 13}{(x^2 + 2)(x - 1)}$$

14.
$$\frac{26x^2 + 208x}{(x^2 + 1)(x + 5)}$$

15.
$$\frac{6 + 26x - x^2}{(2x - 1)(x + 2)^2}$$

16.
$$\frac{5x^3 + 6x^2 + 5x}{(x^2 - 1)(x + 1)^3}$$

17.
$$\frac{6x^3 + 5x^2 + 6x - 2}{2x^2 + x - 1}$$

18.
$$\frac{2x^3 + 3x^2 - 11x - 10}{x^2 + 2x - 3}$$

19.
$$\frac{2x^2 - 11x + 5}{(x - 3)(x^2 + 2x - 5)}$$

20.
$$\frac{3x^2 - 3x - 8}{(x - 5)(x^2 + x - 4)}$$

21.
$$\frac{-4x^2 - 2x + 10}{(3x + 5)(x + 1)^2}$$

22.
$$\frac{26x^2 - 36x + 22}{(x - 4)(2x - 1)^2}$$

23.
$$\frac{36x + 1}{12x^2 - 7x - 10}$$

24.
$$\frac{-17x + 61}{6x^2 + 39x - 21}$$

25.
$$\frac{-4x^2 - 9x + 8}{(3x^2 + 1)(x - 2)}$$

26.
$$\frac{11x^2 - 39x + 16}{(x^2 + 4)(x - 8)}$$

Skill Maintenance

Find the zeros of the polynomial function.

27. $f(x) = x^3 + x^2 + 9x + 9$

28. $f(x) = x^3 - 3x^2 + x - 3$

29. $f(x) = x^3 + x^2 - 3x - 2$

30. $f(x) = x^4 - x^3 - 5x^2 - x - 6$

31. $f(x) = x^3 + 5x^2 + 5x - 3$

Synthesis

Decompose into partial fractions.

32.
$$\frac{9x^3 - 24x^2 + 48x}{(x - 2)^4(x + 1)}$$

[Hint: Let the expression equal

$$\frac{A}{x + 1} + \frac{P(x)}{(x - 2)^4}$$

and find $P(x)$].

33.
$$\frac{x}{x^4 - a^4}$$

34.
$$\frac{1}{e^{-x} + 3 + 2e^x}$$

35.
$$\frac{1 + \ln x^2}{(\ln x + 2)(\ln x - 3)^2}$$

Chapter 9 Summary and Review

STUDY GUIDE

KEY TERMS AND CONCEPTS

EXAMPLES

SECTION 9.1: SYSTEMS OF EQUATIONS IN TWO VARIABLES

A **system of two linear equations in two variables** is composed of two linear equations that are considered simultaneously.

The **solutions** of the system of equations are all ordered pairs that make *both* equations true.

A system of equations is **consistent** if it has at least one solution. A system of equations that has no solution is **inconsistent**.

The equations are **dependent** if one equation can be obtained by multiplying both sides of the other equation by a constant. Otherwise, the equations are **independent**.

Systems of two equations in two variables can be solved graphically.

$$\begin{aligned} \text{Solve: } x + y &= 2, \\ y &= x - 4. \end{aligned}$$

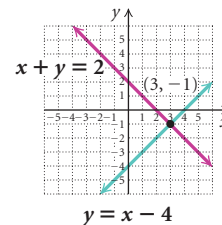

The solution is the point of intersection, $(3, -1)$. The system is consistent. The equations are independent.

$$\begin{aligned} \text{Solve: } x + y &= 2, \\ x + y &= -2. \end{aligned}$$

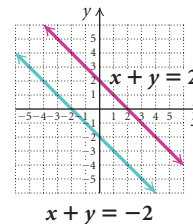

The graphs do not intersect, so there is no solution. The system is inconsistent. The equations are independent.

$$\begin{aligned} \text{Solve: } x + y &= 2, \\ 3x + 3y &= 6. \end{aligned}$$

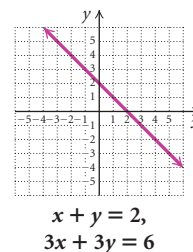

The graphs are the same. There are infinitely many common points, so there are infinitely many solutions. The solutions are of the form $(x, 2 - x)$ or $(2 - y, y)$. The system is consistent. The equations are dependent.

Systems of two equations in two variables can be solved using substitution.

$$\begin{aligned} \text{Solve: } x &= y - 5, \\ 2x + 3y &= 5. \end{aligned}$$

Substitute and solve for y: *Back-substitute and solve for x:*

$$\begin{aligned} 2(y - 5) + 3y &= 5 & x &= y - 5 \\ 2y - 10 + 3y &= 5 & x &= 3 - 5 \\ 5y - 10 &= 5 & x &= -2. \\ 5y &= 15 \\ y &= 3. \end{aligned}$$

The solution is $(-2, 3)$.

Systems of two equations in two variables can be solved using elimination.

$$\begin{aligned} \text{Solve: } 3x + y &= -1, \\ x - 3y &= 8. \end{aligned}$$

Eliminate y and solve for x: *Back-substitute and solve for y:*

$$\begin{aligned} 9x + 3y &= -3 & 3x + y &= -1 \\ x - 3y &= 8 & 3 \cdot \frac{1}{2} + y &= -1 \\ \hline 10x &= 5 & \frac{3}{2} + y &= -1 \\ x &= \frac{1}{2}. & y &= -\frac{5}{2}. \end{aligned}$$

The solution is $\left(\frac{1}{2}, -\frac{5}{2}\right)$.

Some applied problems can be solved by translating to a system of two equations in two variables.

See Examples 6–8 on pp. 744–748.

SECTION 9.2: SYSTEMS OF EQUATIONS IN THREE VARIABLES

A **solution** of a system of equations in three variables is an ordered triple that makes *all* three equations true.

We can use **Gaussian elimination** to solve a system of three equations in three variables by using the operations listed on p. 754 to transform the original system to one of the form

$$\begin{aligned} Ax + By + Cz &= D, \\ Ey + Fz &= G, \\ Hz &= K. \end{aligned}$$

Then we solve the third equation for z and back-substitute to find y and x .

As we see in Example 1 on p. 754, Gaussian elimination can be used to transform the system of equations

$$\begin{aligned} x - 2y + 3z &= 11, \\ 4x + 2y - 3z &= 4, \\ 3x + 3y - z &= 4 \end{aligned}$$

to the equivalent form

$$\begin{aligned} x - 2y + 3z &= 11, \\ 10y - 15z &= -40, \\ 35z &= 70. \end{aligned}$$

$$\begin{aligned} \text{Solve for } z: 35z &= 70 \\ z &= 2. \end{aligned}$$

Back-substitute to find y and x:

$$\begin{aligned} 10y - 15 \cdot 2 &= -40 & x - 2(-1) + 3 \cdot 2 &= 11 \\ 10y - 30 &= -40 & x + 2 + 6 &= 11 \\ 10y &= -10 & x + 8 &= 11 \\ y &= -1. & x &= 3. \end{aligned}$$

The solution is $(3, -1, 2)$.

Some applied problems can be solved by translating to a system of three equations in three variables.

We can use a system of three equations to model a situation with a quadratic function.

See Example 3 on p. 757.

Find a quadratic function that fits the data points $(0, -5)$, $(1, -4)$, and $(2, 1)$.

Substitute in the function $f(x) = ax^2 + bx + c$:

For $(0, -5)$: $-5 = a \cdot 0^2 + b \cdot 0 + c$,

For $(1, -4)$: $-4 = a \cdot 1^2 + b \cdot 1 + c$,

For $(2, 1)$: $1 = a \cdot 2^2 + b \cdot 2 + c$.

We have a system of equations:

$$c = -5,$$

$$a + b + c = -4,$$

$$4a + 2b + c = 1.$$

Solving this system of equations gives $(2, -1, -5)$. Thus,

$$f(x) = 2x^2 - x - 5.$$

SECTION 9.3: MATRICES AND SYSTEMS OF EQUATIONS

A **matrix** (pl., **matrices**) is a rectangular array of numbers called **entries** or **elements** of the matrix.

$$\begin{array}{l} \text{Row 1} \rightarrow \left[\begin{array}{ccc} 3 & -2 & 5 \end{array} \right] \\ \text{Row 2} \rightarrow \left[\begin{array}{ccc} -1 & 4 & -3 \end{array} \right] \\ \qquad \qquad \qquad \uparrow \qquad \uparrow \qquad \nwarrow \\ \qquad \qquad \qquad \text{Column 1 Column 2 Column 3} \end{array}$$

This matrix has 2 rows and 3 columns. Its **order** is 2×3 .

We can apply the **row-equivalent operations** on p. 765 to use **Gaussian elimination** with matrices to solve systems of equations.

Solve: $x - 2y = 8$,
 $2x + y = 1$.

Write the augmented matrix and transform it to **row-echelon form** or **reduced row-echelon form**:

$$\left[\begin{array}{cc|c} 1 & -2 & 8 \\ 2 & 1 & 1 \end{array} \right] \rightarrow \left[\begin{array}{cc|c} 1 & -2 & 8 \\ 0 & 5 & -15 \end{array} \right] \rightarrow \left[\begin{array}{cc|c} 1 & 0 & 2 \\ 0 & 1 & -3 \end{array} \right]$$

\uparrow
 \uparrow

Row-echelon form
Reduced row-echelon form

Then we have $x = 2, y = -3$. The solution is $(2, -3)$.

SECTION 9.4: MATRIX OPERATIONS

Matrices of the same order can be added or subtracted by adding or subtracting their corresponding entries.

$$\begin{aligned} \left[\begin{array}{cc} 3 & -4 \\ -1 & 2 \end{array} \right] + \left[\begin{array}{cc} -5 & -1 \\ 3 & 0 \end{array} \right] &= \left[\begin{array}{cc} 3 + (-5) & -4 + (-1) \\ -1 + 3 & 2 + 0 \end{array} \right] \\ &= \left[\begin{array}{cc} -2 & -5 \\ 2 & 2 \end{array} \right] \\ \left[\begin{array}{cc} 3 & -4 \\ -1 & 2 \end{array} \right] - \left[\begin{array}{cc} -5 & -1 \\ 3 & 0 \end{array} \right] &= \left[\begin{array}{cc} 3 - (-5) & -4 - (-1) \\ -1 - 3 & 2 - 0 \end{array} \right] \\ &= \left[\begin{array}{cc} 8 & -3 \\ -4 & 2 \end{array} \right] \end{aligned}$$

The **scalar product** of a number k and a matrix \mathbf{A} is the matrix $k\mathbf{A}$ obtained by multiplying each entry of \mathbf{A} by k . The number k is called a **scalar**.

The properties of matrix addition and scalar multiplication are given on p. 775.

For an $m \times n$ matrix $\mathbf{A} = [a_{ij}]$ and an $n \times p$ matrix $\mathbf{B} = [b_{ij}]$, the **product** $\mathbf{AB} = [c_{ij}]$ is an $m \times p$ matrix, where

$$c_{ij} = a_{i1} \cdot b_{1j} + a_{i2} \cdot b_{2j} + a_{i3} \cdot b_{3j} + \cdots + a_{in} \cdot b_{nj}.$$

The properties of matrix multiplication are given on p. 779.

We can write a matrix equation equivalent to a system of equations.

For $\mathbf{A} = \begin{bmatrix} 2 & 3 & -1 \\ -4 & -2 & 5 \end{bmatrix}$, find $2\mathbf{A}$.

$$\begin{aligned} 2\mathbf{A} &= 2 \begin{bmatrix} 2 & 3 & -1 \\ -4 & -2 & 5 \end{bmatrix} = \begin{bmatrix} 2 \cdot 2 & 2 \cdot 3 & 2 \cdot (-1) \\ 2 \cdot (-4) & 2 \cdot (-2) & 2 \cdot 5 \end{bmatrix} \\ &= \begin{bmatrix} 4 & 6 & -2 \\ -8 & -4 & 10 \end{bmatrix} \end{aligned}$$

For $\mathbf{A} = \begin{bmatrix} 4 & -1 & 3 \\ 0 & -2 & 1 \end{bmatrix}$ and $\mathbf{B} = \begin{bmatrix} -3 & 1 \\ 3 & 4 \\ 2 & -1 \end{bmatrix}$, find \mathbf{AB} .

$$\begin{aligned} \mathbf{AB} &= \begin{bmatrix} 4 & -1 & 3 \\ 0 & -2 & 1 \end{bmatrix} \begin{bmatrix} -3 & 1 \\ 3 & 4 \\ 2 & -1 \end{bmatrix} \\ &= \begin{bmatrix} 4 \cdot (-3) + (-1) \cdot 3 + 3 \cdot 2 & 4 \cdot 1 + (-1) \cdot 4 + 3 \cdot (-1) \\ 0 \cdot (-3) + (-2) \cdot 3 + 1 \cdot 2 & 0 \cdot 1 + (-2) \cdot 4 + 1 \cdot (-1) \end{bmatrix} \\ &= \begin{bmatrix} -9 & -3 \\ -4 & -9 \end{bmatrix} \end{aligned}$$

Write a matrix equation equivalent to the system of equations:

$$2x - 3y = 6,$$

$$x - 4y = 1.$$

This system of equations can be written as

$$\begin{bmatrix} 2 & -3 \\ 1 & -4 \end{bmatrix} \begin{bmatrix} x \\ y \end{bmatrix} = \begin{bmatrix} 6 \\ 1 \end{bmatrix}.$$

SECTION 9.5: INVERSES OF MATRICES

The $n \times n$ **identity matrix** \mathbf{I} is an $n \times n$ matrix with 1's on the main diagonal and 0's elsewhere.

For any $n \times n$ matrix \mathbf{A} ,

$$\mathbf{AI} = \mathbf{IA} = \mathbf{A}.$$

For an $n \times n$ matrix \mathbf{A} , if there is a matrix \mathbf{A}^{-1} for which $\mathbf{A}^{-1} \cdot \mathbf{A} = \mathbf{I} = \mathbf{A} \cdot \mathbf{A}^{-1}$, then \mathbf{A}^{-1} is the **inverse** of \mathbf{A} .

The inverse of an $n \times n$ matrix \mathbf{A} can be found by first writing an augmented matrix consisting of \mathbf{A} on the left side and the $n \times n$ identity matrix on the right side. Then row-equivalent operations are used to transform the augmented matrix to a matrix with the $n \times n$ identity matrix on the left side and the inverse on the right side.

See Examples 3 and 4 on pp. 787 and 788.

For a system of n linear equations in n variables, $\mathbf{AX} = \mathbf{B}$, if \mathbf{A} has an inverse, then the solution of the system of equations is given by

$$\mathbf{X} = \mathbf{A}^{-1}\mathbf{B}.$$

Since matrix multiplication is not commutative, in general, \mathbf{B} must be multiplied *on the left* by \mathbf{A}^{-1} .

Use an inverse matrix to solve the following system of equations:

$$\begin{aligned}x - y &= 1, \\x - 2y &= -1.\end{aligned}$$

First write an equivalent matrix equation:

$$\begin{bmatrix} 1 & -1 \\ 1 & -2 \end{bmatrix} \cdot \begin{bmatrix} x \\ y \end{bmatrix} = \begin{bmatrix} 1 \\ -1 \end{bmatrix}.$$

$$\mathbf{A} \cdot \mathbf{X} = \mathbf{B}$$

Then find \mathbf{A}^{-1} and multiply *on the left* by \mathbf{A}^{-1} :

$$\mathbf{X} = \mathbf{A}^{-1} \cdot \mathbf{B}$$

$$\begin{bmatrix} x \\ y \end{bmatrix} = \begin{bmatrix} 2 & -1 \\ 1 & -1 \end{bmatrix} \begin{bmatrix} 1 \\ -1 \end{bmatrix} = \begin{bmatrix} 3 \\ 2 \end{bmatrix}.$$

The solution is $(3, 2)$.

SECTION 9.6: DETERMINANTS AND CRAMER'S RULE

Determinant of a 2×2 Matrix

The determinant of the matrix $\begin{bmatrix} a & c \\ b & d \end{bmatrix}$ is

denoted by $\begin{vmatrix} a & c \\ b & d \end{vmatrix}$ and is defined as

$$\begin{vmatrix} a & c \\ b & d \end{vmatrix} = ad - bc.$$

The **determinant** of any **square matrix** can be found by *expanding across a row or down a column*. See p. 794.

We can use determinants to solve systems of linear equations.

Cramer's rule for a 2×2 system is given on p. 796. Cramer's rule for a 3×3 system is given on p. 797.

Evaluate: $\begin{vmatrix} 3 & -4 \\ 2 & 1 \end{vmatrix}$.

$$\begin{vmatrix} 3 & -4 \\ 2 & 1 \end{vmatrix} = 3 \cdot 1 - 2(-4) = 3 + 8 = 11$$

See Example 4 on p. 794.

Solve: $2x - 3y = 2$,

$$6x + 6y = 1.$$

$$x = \frac{\begin{vmatrix} 2 & -3 \\ 1 & 6 \end{vmatrix}}{\begin{vmatrix} 2 & -3 \\ 6 & 6 \end{vmatrix}}, \quad y = \frac{\begin{vmatrix} 2 & 2 \\ 6 & 1 \end{vmatrix}}{\begin{vmatrix} 2 & -3 \\ 6 & 6 \end{vmatrix}}$$

$$x = \frac{15}{30} = \frac{1}{2}, \quad y = \frac{-10}{30} = -\frac{1}{3}.$$

The solution is $\left(\frac{1}{2}, -\frac{1}{3}\right)$.

SECTION 9.7: SYSTEMS OF INEQUALITIES AND LINEAR PROGRAMMING

To graph a linear inequality in two variables:

1. Graph the related equation. Draw a dashed line if the inequality symbol is $<$ or $>$; draw a solid line if the inequality symbol is \leq or \geq .
2. Use a test point to determine which half-plane to shade.

Graph: $x + y > 2$.

1. Graph $x + y = 2$ using a dashed line.
2. Test a point not on the line. We use $(0, 0)$.

$$\begin{array}{r} x + y > 2 \\ 0 + 0 \quad ? \quad 2 \\ 0 \quad | \quad \text{FALSE} \end{array}$$

Since $0 > 2$ is false, shade the half-plane that does not contain $(0, 0)$.

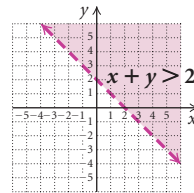

To graph a system of inequalities, graph each inequality and determine the region that is common to all the solution sets.

Graph the solution set of the system

$$\begin{array}{l} x - y \leq 3, \\ 2x + y \geq 4. \end{array}$$

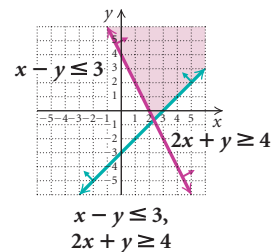

The maximum or minimum value of an **objective function** over a region of **feasible solutions** is the maximum or minimum value of the function at a vertex of that region.

Maximize $G = 8x - 5y$ subject to

$$\begin{array}{l} x + y \leq 3, \\ x \geq 0, \\ y \geq 1. \end{array}$$

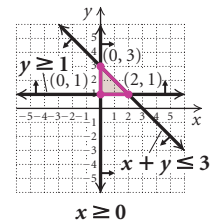

Vertex	$G = 8x - 5y$
$(0, 1)$	$G = 8 \cdot 0 - 5 \cdot 1 = -5$
$(0, 3)$	$G = 8 \cdot 0 - 5 \cdot 3 = -15$
$(2, 1)$	$G = 8 \cdot 2 - 5 \cdot 1 = 11$

← Maximum

SECTION 9.8: PARTIAL FRACTIONS

The procedure for **decomposing a rational expression into partial fractions** is given on p. 813.

See Examples 1–5 on pp. 814–817.

REVIEW EXERCISES

Determine whether the statement is true or false.

1. A system of equations with exactly one solution is consistent and has independent equations. [9.1]
2. A system of two linear equations in two variables can have exactly two solutions. [9.1]
3. For any $m \times n$ matrices A and B , $A + B = B + A$. [9.4]
4. In general, matrix multiplication is commutative. [9.4]

In Exercises 5–12, match the equations or inequalities with one of the graphs (a)–(h), which follow.

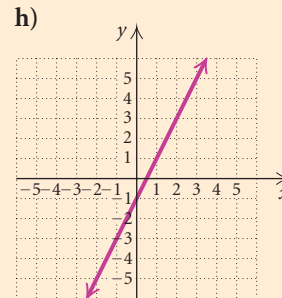
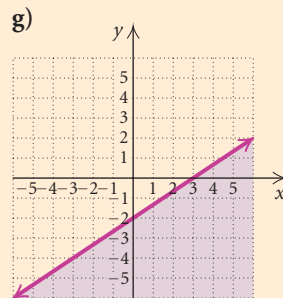
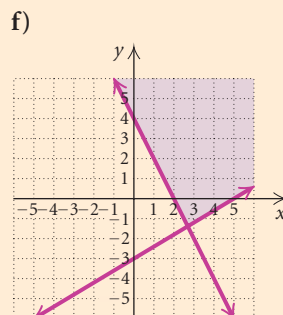
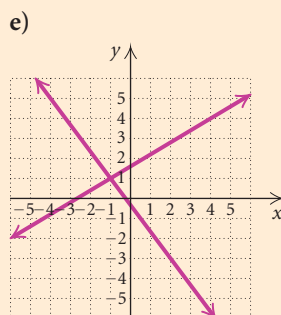
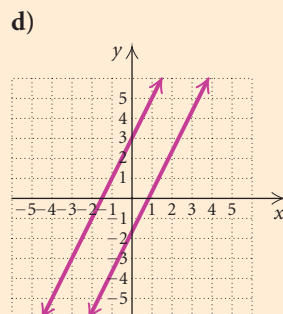
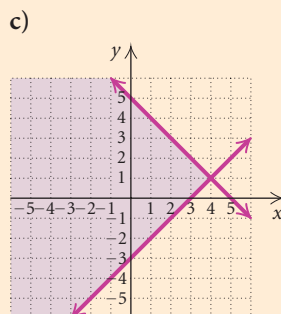
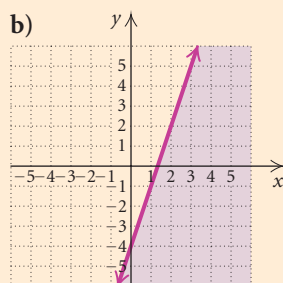
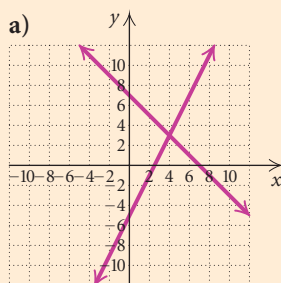

5. $x + y = 7$,
 $2x - y = 5$ [9.1]
6. $3x - 5y = -8$,
 $4x + 3y = -1$ [9.1]
7. $y = 2x - 1$,
 $4x - 2y = 2$ [9.1]
8. $6x - 3y = 5$,
 $y = 2x + 3$ [9.1]
9. $y \leq 3x - 4$ [9.7]
10. $2x - 3y \geq 6$ [9.7]
11. $x - y \leq 3$,
 $x + y \leq 5$ [9.7]
12. $2x + y \geq 4$,
 $3x - 5y \leq 15$ [9.7]

Solve.

13. $5x - 3y = -4$,
 $3x - y = -4$ [9.1]
14. $2x + 3y = 2$,
 $5x - y = -29$ [9.1]
15. $x + 5y = 12$,
 $5x + 25y = 12$ [9.1]
16. $x + y = -2$,
 $-3x - 3y = 6$ [9.1]
17. $x + 5y - 3z = 4$,
 $3x - 2y + 4z = 3$,
 $2x + 3y - z = 5$ [9.2]
18. $2x - 4y + 3z = -3$,
 $-5x + 2y - z = 7$,
 $3x + 2y - 2z = 4$ [9.2]
19. $x - y = 5$,
 $y - z = 6$,
 $z - w = 7$,
 $x + w = 8$ [9.2]
20. Classify each of the systems in Exercises 13–19 as consistent or inconsistent. [9.1], [9.2]
21. Classify each of the systems in Exercises 13–19 as having dependent equations or independent equations. [9.1], [9.2]

Find \mathbf{A}^{-1} , if it exists. [9.5]

40. $\mathbf{A} = \begin{bmatrix} -2 & 0 \\ 1 & 3 \end{bmatrix}$

41. $\mathbf{A} = \begin{bmatrix} 0 & 0 & 3 \\ 0 & -2 & 0 \\ 4 & 0 & 0 \end{bmatrix}$

42. $\mathbf{A} = \begin{bmatrix} 1 & 0 & 0 & 0 \\ 0 & 4 & -5 & 0 \\ 0 & 2 & 2 & 0 \\ 0 & 0 & 0 & 1 \end{bmatrix}$

43. Write a matrix equation equivalent to this system of equations:

$$3x - 2y + 4z = 13,$$

$$x + 5y - 3z = 7,$$

$$2x - 3y + 7z = -8. \quad [9.4]$$

Solve the system of equations using the inverse of the coefficient matrix of the equivalent matrix equation. [9.5]

44. $2x + 3y = 5,$
 $3x + 5y = 11$

45. $5x - y + 2z = 17,$
 $3x + 2y - 3z = -16,$
 $4x - 3y - z = 5$

46. $w - x - y + z = -1,$
 $2w + 3x - 2y - z = 2,$
 $-w + 5x + 4y - 2z = 3,$
 $3w - 2x + 5y + 3z = 4$

Evaluate the determinant. [9.6]

47. $\begin{vmatrix} 1 & -2 \\ 3 & 4 \end{vmatrix}$

48. $\begin{vmatrix} \sqrt{3} & -5 \\ -3 & -\sqrt{3} \end{vmatrix}$

49. $\begin{vmatrix} 2 & -1 & 1 \\ 1 & 2 & -1 \\ 3 & 4 & -3 \end{vmatrix}$

50. $\begin{vmatrix} 1 & -1 & 2 \\ -1 & 2 & 0 \\ -1 & 3 & 1 \end{vmatrix}$

Solve using Cramer's rule. [9.6]

51. $5x - 2y = 19,$
 $7x + 3y = 15$

52. $x + y = 4,$
 $4x + 3y = 11$

53. $3x - 2y + z = 5,$
 $4x - 5y - z = -1,$
 $3x + 2y - z = 4$

54. $2x - y - z = 2,$
 $3x + 2y + 2z = 10,$
 $x - 5y - 3z = -2$

Graph. [9.7]

55. $y \leq 3x + 6$

56. $4x - 3y \geq 12$

57. Graph this system of inequalities and find the coordinates of any vertices formed. [9.7]

$$2x + y \geq 9,$$

$$4x + 3y \geq 23,$$

$$x + 3y \geq 8,$$

$$x \geq 0,$$

$$y \geq 0$$

58. Find the maximum value and the minimum value of $T = 6x + 10y$ subject to

$$x + y \leq 10,$$

$$5x + 10y \geq 50,$$

$$x \geq 2,$$

$$y \geq 0. \quad [9.7]$$

59. **Maximizing a Test Score.** Marita is taking a test that contains questions in group A worth 7 points each and questions in group B worth 12 points each. The total number of questions answered must be at least 8. If Marita knows that group A questions take 8 min each and group B questions take 10 min each and the maximum time for the test is 80 min, how many questions from each group must she answer correctly in order to maximize her score? What is the maximum score? [9.7]

Decompose into partial fractions. [9.8]

60. $\frac{5}{(x+2)^2(x+1)}$

61. $\frac{-8x+23}{2x^2+5x-12}$

62. Solve: $2x + y = 7,$
 $x - 2y = 6. \quad [9.1]$

- A. x and y are both positive numbers.
- B. x and y are both negative numbers.
- C. x is positive and y is negative.
- D. x is negative and y is positive.

63. Which is *not* a row-equivalent operation on a matrix? [9.3]

- A. Interchange any two columns.
- B. Interchange any two rows.
- C. Add two rows.
- D. Multiply each entry in a row by -3 .

64. The graph of the given system of inequalities is which of the following? [9.7]

$$x + y \leq 3,$$

$$x - y \leq 4$$

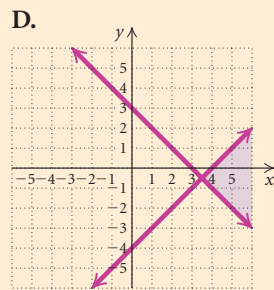
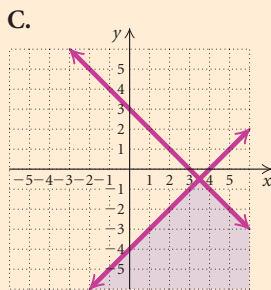
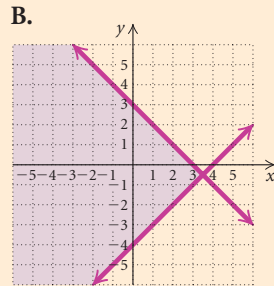
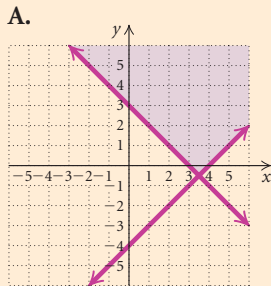

Synthesis

65. One year, Don invested a total of \$40,000, part at 4%, part at 5%, and the rest at $5\frac{1}{2}\%$. The total amount of interest received on the investments was \$1990. The interest received on the $5\frac{1}{2}\%$ investment was \$590 more than the interest received on the 4% investment. How much was invested at each rate? [9.2]

Solve.

66.
$$\frac{2}{3x} + \frac{4}{5y} = 8,$$

$$\frac{5}{4x} - \frac{3}{2y} = -6$$
 [9.1]

67.
$$\frac{3}{x} - \frac{4}{y} + \frac{1}{z} = -2,$$

$$\frac{5}{x} + \frac{1}{y} - \frac{2}{z} = 1,$$

$$\frac{7}{x} + \frac{3}{y} + \frac{2}{z} = 19$$
 [9.2]

Graph. [9.7]

68. $|x| - |y| \leq 1$

69. $|xy| > 1$

Collaborative Discussion and Writing

70. Cassidy solves the equation $2x + 5 = 3x - 7$ by finding the point of intersection of the graphs of $y_1 = 2x + 5$ and $y_2 = 3x - 7$. She finds the same point when she solves the system of equations

$$y = 2x + 5,$$

$$y = 3x - 7.$$

Explain the difference between the solution of the equation and the solution of the system of equations. [9.1]

71. For square matrices **A** and **B**, is it true, in general, that $(\mathbf{AB})^2 = \mathbf{A}^2\mathbf{B}^2$? Explain. [9.4]

72. Given the system of equations

$$a_1x + b_1y = c_1,$$

$$a_2x + b_2y = c_2,$$

explain why the equations are dependent or the system is inconsistent when

$$\begin{vmatrix} a_1 & b_1 \\ a_2 & b_2 \end{vmatrix} = 0. \text{ [9.6]}$$

73. If the lines $a_1x + b_1y = c_1$ and $a_2x + b_2y = c_2$ are parallel, what can you say about the values of

$$\begin{vmatrix} a_1 & b_1 \\ a_2 & b_2 \end{vmatrix}, \quad \begin{vmatrix} c_1 & b_1 \\ c_2 & b_2 \end{vmatrix}, \quad \text{and} \quad \begin{vmatrix} a_1 & c_1 \\ a_2 & c_2 \end{vmatrix}?$$
 [9.6]

74. Describe how the graph of a linear inequality differs from the graph of a linear equation. [9.7]

75. What would you say to a classmate who tells you that the partial fraction decomposition of

$$\frac{3x^2 - 8x + 9}{(x + 3)(x^2 - 5x + 6)}$$

is

$$\frac{2}{x + 3} + \frac{x - 1}{x^2 - 5x + 6}?$$

Explain. [9.8]

Chapter 9 Test

Solve. Use any method. Also determine whether the system is consistent or inconsistent and whether the equations are dependent or independent.

- $3x + 2y = 1,$
 $2x - y = -11$
- $2x - y = 3,$
 $2y = 4x - 6$
- $x - y = 4,$
 $3y = 3x - 8$
- $2x - 3y = 8,$
 $5x - 2y = 9$

Solve.

- $4x + 2y + z = 4,$
 $3x - y + 5z = 4,$
 $5x + 3y - 3z = -2$
- Ticket Sales.** One evening 750 tickets were sold for Shortridge Community College's spring musical. Tickets cost \$3 for students and \$5 for nonstudents. Total receipts were \$3066. How many of each type of ticket were sold?
- Tricia, Maria, and Antonio can process 352 telephone orders per day. Tricia and Maria together can process 224 orders per day while Tricia and Antonio together can process 248 orders per day. How many orders can each of them process alone?

For Exercises 8–13, let

$$\mathbf{A} = \begin{bmatrix} 1 & -1 & 3 \\ -2 & 5 & 2 \end{bmatrix}, \quad \mathbf{B} = \begin{bmatrix} -5 & 1 \\ -2 & 4 \end{bmatrix},$$

and

$$\mathbf{C} = \begin{bmatrix} 3 & -4 \\ -1 & 0 \end{bmatrix}.$$

Find each of the following, if possible.

- $\mathbf{B} + \mathbf{C}$
- $\mathbf{A} - \mathbf{C}$
- \mathbf{CB}
- \mathbf{AB}
- $2\mathbf{A}$
- \mathbf{C}^{-1}
- Food Service Management.** The table below lists the cost per serving, in dollars, for items on three lunch menus served at a senior citizens' center.

Menu	Main Dish	Side Dish	Dessert
1	0.95	0.40	0.39
2	1.10	0.35	0.41
3	1.05	0.39	0.36

On a particular day, 26 Menu 1 meals, 18 Menu 2 meals, and 23 Menu 3 meals are served.

- Write the information in the table as a 3×3 matrix \mathbf{M} .
 - Write a row matrix \mathbf{N} that represents the number of each menu served.
 - Find the product \mathbf{NM} .
 - State what the entries of \mathbf{NM} represent.
15. Write a matrix equation equivalent to the system of equations

$$\begin{aligned} 3x - 4y + 2z &= -8, \\ 2x + 3y + z &= 7, \\ x - 5y - 3z &= 3. \end{aligned}$$

16. Solve the system of equations using the inverse of the coefficient matrix of the equivalent matrix equation.

$$\begin{aligned} 3x + 2y + 6z &= 2, \\ x + y + 2z &= 1, \\ 2x + 2y + 5z &= 3 \end{aligned}$$

Evaluate the determinant.

$$17. \begin{vmatrix} 3 & -5 \\ 8 & 7 \end{vmatrix} \qquad 18. \begin{vmatrix} 2 & -1 & 4 \\ -3 & 1 & -2 \\ 5 & 3 & -1 \end{vmatrix}$$

19. Solve using Cramer's rule. Show your work.

$$\begin{aligned} 5x + 2y &= -1, \\ 7x + 6y &= 1 \end{aligned}$$

20. Graph: $3x + 4y \leq -12$.

21. Find the maximum value and the minimum value of $Q = 2x + 3y$ subject to

$$\begin{aligned}x + y &\leq 6, \\2x - 3y &\geq -3, \\x &\geq 1, \\y &\geq 0.\end{aligned}$$

22. **Maximizing Profit.** Casey's Cakes prepares pound cakes and carrot cakes. In a given week, at most 100 cakes can be prepared, of which 25 pound cakes and 15 carrot cakes are required by regular customers. The profit from each pound cake is \$3 and the profit from each carrot cake is \$4. How many of each type of cake should be prepared in order to maximize the profit? What is the maximum profit?

23. Decompose into partial fractions:

$$\frac{3x - 11}{x^2 + 2x - 3}$$

24. The graph of the given system of inequalities is which of the following?

$$\begin{aligned}x + 2y &\geq 4, \\x - y &\leq 2\end{aligned}$$

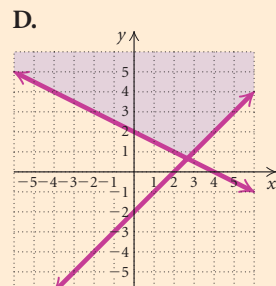
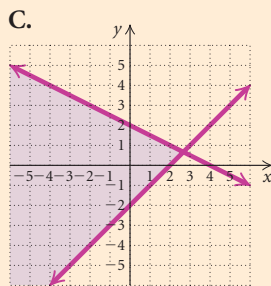
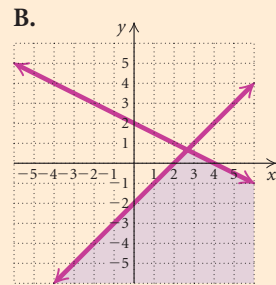
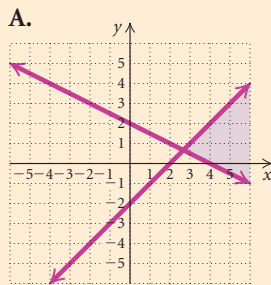

Synthesis

25. Three solutions of the equation $Ax - By = Cz - 8$ are $(2, -2, 2)$, $(-3, -1, 1)$, and $(4, 2, 9)$. Find A , B , and C .

Analytic Geometry Topics

CHAPTER

10



Application

Green Leaf Landscaping is planting a rectangular flower garden with a perimeter of 6 m and a diagonal of $\sqrt{5}$ m. Find the dimensions of the garden.

This problem appears as Exercise 62 in Section 10.4.

- 10.1 The Parabola
- 10.2 The Circle and the Ellipse
- 10.3 The Hyperbola
- 10.4 Nonlinear Systems of Equations and Inequalities
- Visualizing the Graph
- Mid-Chapter Mixed Review
- 10.5 Rotation of Axes
- 10.6 Polar Equations of Conics
- 10.7 Parametric Equations
- Study Guide
- Review Exercises
- Chapter Test

The Parabola

10.1

- Given an equation of a parabola, complete the square, if necessary, and then find the vertex, the focus, and the directrix and graph the parabola.

A **conic section** is formed when a right circular cone with two parts, called *nappes*, is intersected by a plane. One of four types of curves can be formed: a parabola, a circle, an ellipse, or a hyperbola.

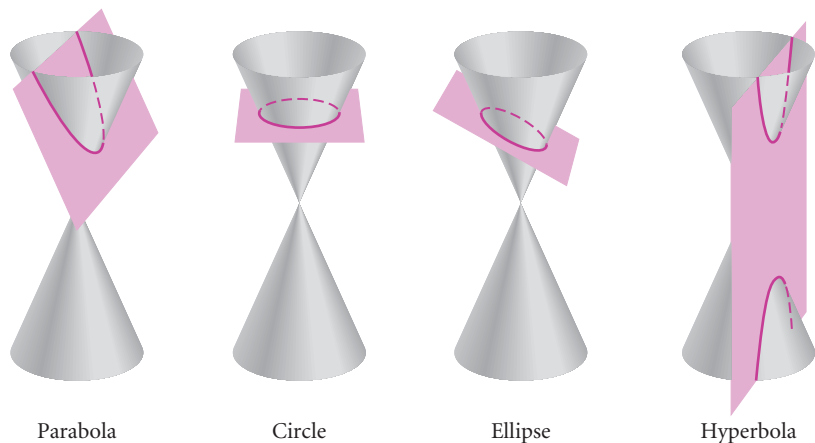

Parabola

Circle

Ellipse

Hyperbola

Conic Sections

Conic sections can be defined algebraically using second-degree equations of the form $Ax^2 + Bxy + Cy^2 + Dx + Ey + F = 0$. In addition, they can be defined geometrically as a set of points that satisfy certain conditions.

► Parabolas

In Section 3.3, we saw that the graph of the quadratic function $f(x) = ax^2 + bx + c$, $a \neq 0$, is a parabola. A parabola can be defined geometrically.

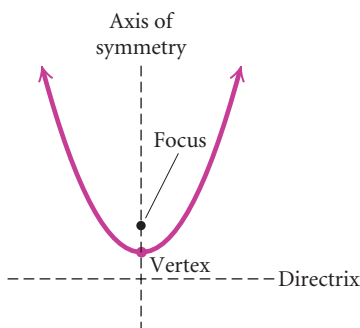

Parabola

A **parabola** is the set of all points in a plane equidistant from a fixed line (the **directrix**) and a fixed point not on the line (the **focus**).

The line that is perpendicular to the directrix and contains the focus is the **axis of symmetry**. The **vertex** is the midpoint of the segment between the focus and the directrix. (See the figure at left.)

Let's derive the standard equation of a parabola with vertex $(0, 0)$ and directrix $y = -p$, where $p > 0$. We place the coordinate axes as shown in Fig. 1. The y -axis is the axis of symmetry and contains the focus F . The distance from the focus to the vertex is the same as the distance from the vertex to the directrix. Thus the coordinates of F are $(0, p)$.

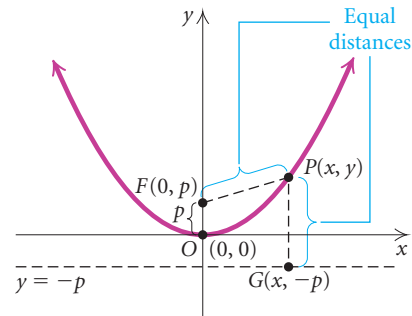

Figure 1

Let $P(x, y)$ be any point on the parabola and consider \overline{PG} perpendicular to the line $y = -p$. The coordinates of G are $(x, -p)$. By the definition of a parabola,

$$PF = PG. \quad \text{The distance from } P \text{ to the focus is the same as the distance from } P \text{ to the directrix.}$$

Then using the distance formula, we have

$$\begin{aligned} \sqrt{(x-0)^2 + (y-p)^2} &= \sqrt{(x-x)^2 + [y - (-p)]^2} \\ x^2 + y^2 - 2py + p^2 &= y^2 + 2py + p^2 && \text{Squaring both sides and} \\ &&& \text{squaring the binomials} \\ x^2 &= 4py. \end{aligned}$$

We have shown that if $P(x, y)$ is on the parabola shown in Fig. 1, then its coordinates satisfy this equation. The converse is also true, but we will not prove it here.

Note that if $p > 0$, as above, the graph opens up. If $p < 0$, the graph opens down.

The equation of a parabola with vertex $(0, 0)$ and directrix $x = -p$ is derived similarly. Such a parabola opens either to the right ($p > 0$), as shown in Fig. 2, or to the left ($p < 0$).

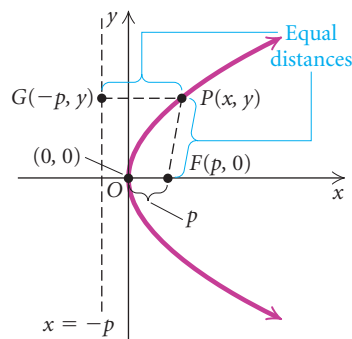

Figure 2

Standard Equation of a Parabola with Vertex at the Origin

The standard equation of a parabola with vertex $(0, 0)$ and directrix $y = -p$ is

$$x^2 = 4py.$$

The focus is $(0, p)$ and the y -axis is the axis of symmetry.

The standard equation of a parabola with vertex $(0, 0)$ and directrix $x = -p$ is

$$y^2 = 4px.$$

The focus is $(p, 0)$ and the x -axis is the axis of symmetry.

EXAMPLE 1 Find the vertex, the focus, and the directrix of the parabola $y = -\frac{1}{12}x^2$. Then graph the parabola.

Solution We write $y = -\frac{1}{12}x^2$ in the form $x^2 = 4py$:

$$\begin{aligned} -\frac{1}{12}x^2 &= y && \text{Given equation} \\ x^2 &= -12y && \text{Multiplying by } -12 \text{ on both sides} \\ x^2 &= 4(-3)y. && \text{Standard form} \end{aligned}$$

Since the equation can be written in the form $x^2 = 4py$, we know that the vertex is $(0, 0)$.

We have $p = -3$, so the focus is $(0, p)$, or $(0, -3)$. The directrix is $y = -p = -(-3) = 3$.

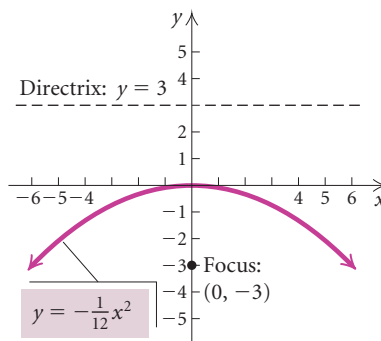

➔ Now Try Exercise 7.

TECHNOLOGY CONNECTION

We can use a graphing calculator to graph parabolas. Consider the parabola in Example 2. It might be necessary to solve the equation for y before entering it in the calculator:

$$\begin{aligned} y^2 &= 20x \\ y &= \pm\sqrt{20x}. \end{aligned}$$

We now graph $y_1 = \sqrt{20x}$ and $y_2 = -\sqrt{20x}$ or $y_1 = \sqrt{20x}$ and $y_2 = -y_1$ in a squared viewing window.

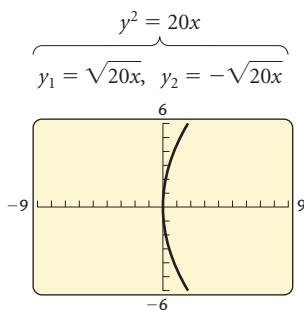

On some graphing calculators, the Conics application from the APPS menu can be used to graph parabolas. This method will be discussed following Example 4.

EXAMPLE 2 Find an equation of the parabola with vertex $(0, 0)$ and focus $(5, 0)$. Then graph the parabola.

Solution The focus is on the x -axis so the line of symmetry is the x -axis. Thus the equation is of the type

$$y^2 = 4px.$$

Since the focus $(5, 0)$ is 5 units to the right of the vertex, $p = 5$ and the equation is

$$y^2 = 4(5)x, \quad \text{or} \quad y^2 = 20x.$$

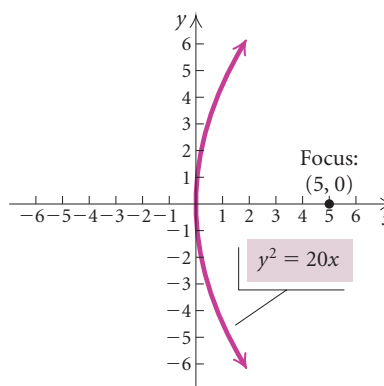

➔ Now Try Exercise 15.

► Finding Standard Form by Completing the Square

If a parabola with vertex at the origin is translated horizontally $|h|$ units and vertically $|k|$ units, it has an equation as follows.

Standard Equation of a Parabola with Vertex (h, k) and Vertical Axis of Symmetry

The standard equation of a parabola with vertex (h, k) and vertical axis of symmetry is

$$(x - h)^2 = 4p(y - k),$$

where the vertex is (h, k) , the focus is $(h, k + p)$, and the directrix is $y = k - p$.

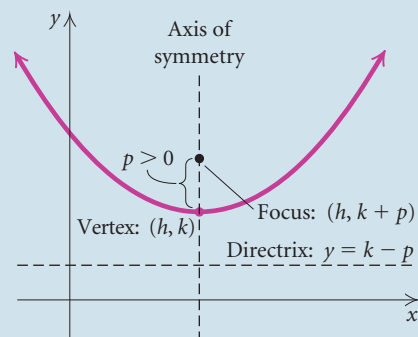

(When $p < 0$, the parabola opens down.)

Standard Equation of a Parabola with Vertex (h, k) and Horizontal Axis of Symmetry

The standard equation of a parabola with vertex (h, k) and horizontal axis of symmetry is

$$(y - k)^2 = 4p(x - h),$$

where the vertex is (h, k) , the focus is $(h + p, k)$, and the directrix is $x = h - p$.

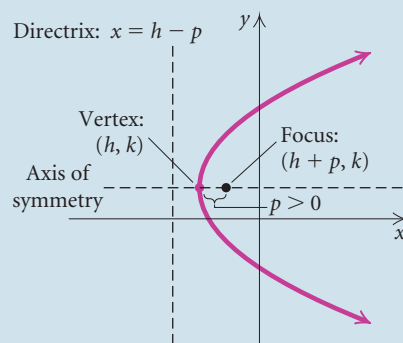

(When $p < 0$, the parabola opens to the left.)

COMPLETING THE SQUARE

REVIEW SECTION 3.2

We can complete the square on equations of the form
 $y = ax^2 + bx + c$ or $x = ay^2 + by + c$
 in order to write them in standard form.

EXAMPLE 3 For the parabola

$$x^2 + 6x + 4y + 5 = 0,$$

find the vertex, the focus, and the directrix. Then draw the graph.

TECHNOLOGY CONNECTION

We can check the graph in Example 3 on a graphing calculator using a squared viewing window. It might be necessary to solve for y first:

$$\begin{aligned}x^2 + 6x + 4y + 5 &= 0 \\4y &= -x^2 - 6x - 5 \\y &= \frac{1}{4}(-x^2 - 6x - 5).\end{aligned}$$

The graph at right appears to be correct.

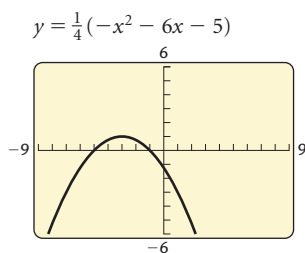

Solution We first complete the square:

$$\begin{aligned}x^2 + 6x + 4y + 5 &= 0 \\x^2 + 6x &= -4y - 5 \\x^2 + 6x + 9 &= -4y - 5 + 9 \\x^2 + 6x + 9 &= -4y + 4 \\(x + 3)^2 &= -4(y - 1) \\[x - (-3)]^2 &= 4(-1)(y - 1).\end{aligned}$$

Subtracting $4y$ and 5 on both sides
Adding 9 on both sides to complete the square on the left side

Factoring
Writing standard form:
 $(x - h)^2 = 4p(y - k)$

We see that $h = -3$, $k = 1$, and $p = -1$, so we have the following:

$$\begin{aligned}\text{Vertex } (h, k): & \quad (-3, 1); \\ \text{Focus } (h, k + p): & \quad (-3, 1 + (-1)), \text{ or } (-3, 0); \\ \text{Directrix } y = k - p: & \quad y = 1 - (-1), \text{ or } y = 2.\end{aligned}$$

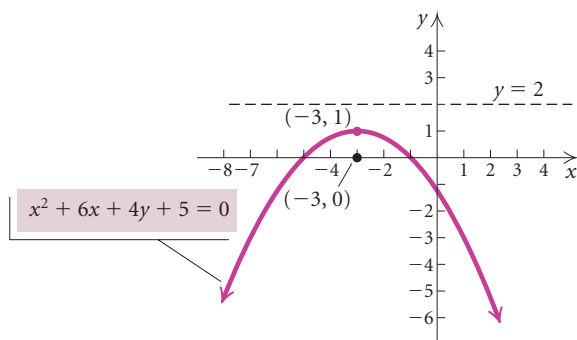

➔ Now Try Exercise 23.

EXAMPLE 4 For the parabola

$$y^2 - 2y - 8x - 31 = 0,$$

find the vertex, the focus, and the directrix. Then draw the graph.

Solution We first complete the square:

$$\begin{aligned}y^2 - 2y - 8x - 31 &= 0 \\y^2 - 2y &= 8x + 31 \\y^2 - 2y + 1 &= 8x + 31 + 1 \\y^2 - 2y + 1 &= 8x + 32 \\(y - 1)^2 &= 8(x + 4) \\(y - 1)^2 &= 4(2)[x - (-4)].\end{aligned}$$

Adding $8x$ and 31 on both sides
Adding 1 on both sides to complete the square on the left side

Factoring
Writing standard form:
 $(y - k)^2 = 4p(x - h)$

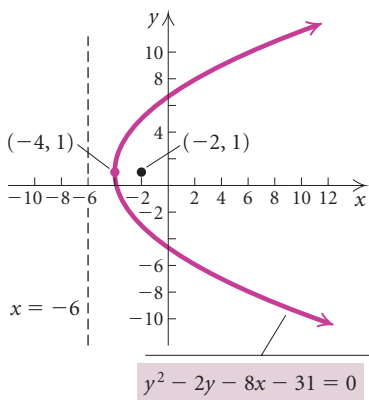

We see that $h = -4$, $k = 1$, and $p = 2$, so we have the following:

$$\text{Vertex } (h, k): \quad (-4, 1);$$

$$\text{Focus } (h + p, k): \quad (-4 + 2, 1), \text{ or } (-2, 1);$$

$$\text{Directrix } x = h - p: \quad x = -4 - 2, \text{ or } x = -6.$$

 **Now Try Exercise 29.**

TECHNOLOGY CONNECTION

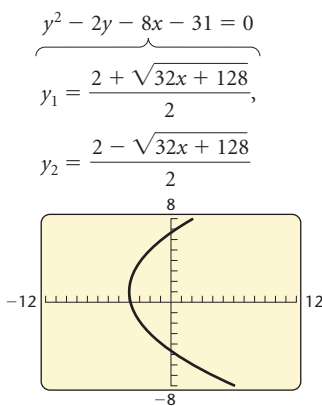

We can check the graph in Example 4 on a graphing calculator by first solving the original equation for y using the quadratic formula:

$$y^2 - 2y - 8x - 31 = 0$$

$$y^2 - 2y + (-8x - 31) = 0$$

$$a = 1, \quad b = -2, \quad c = -8x - 31$$

$$y = \frac{-(-2) \pm \sqrt{(-2)^2 - 4 \cdot 1(-8x - 31)}}{2 \cdot 1}$$

$$y = \frac{2 \pm \sqrt{32x + 128}}{2}.$$

We now graph

$$y_1 = \frac{2 + \sqrt{32x + 128}}{2} \quad \text{and} \quad y_2 = \frac{2 - \sqrt{32x + 128}}{2}$$

in a square viewing window.

When the equation of a parabola is written in standard form, we can use the Conics PARABOLA APP to graph it.

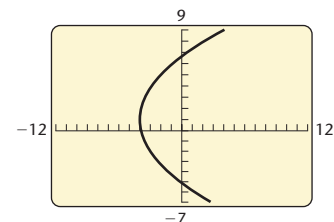
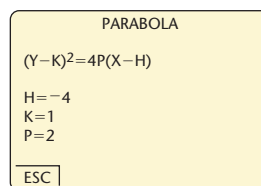

► Applications

Parabolas have many applications. For example, cross sections of car headlights, flashlights, and searchlights are parabolas. The bulb is located at the focus and light from that point is reflected outward parallel to the axis of symmetry. Satellite dishes and field microphones used at sporting events often have parabolic cross sections. Incoming radio waves or sound waves parallel to the axis are reflected into the focus.

Similarly, in solar cooking, a parabolic mirror is mounted on a rack with a cooking pot hung in the focal area. Incoming sun rays parallel to the axis are reflected into the focus, producing a temperature high enough for cooking.

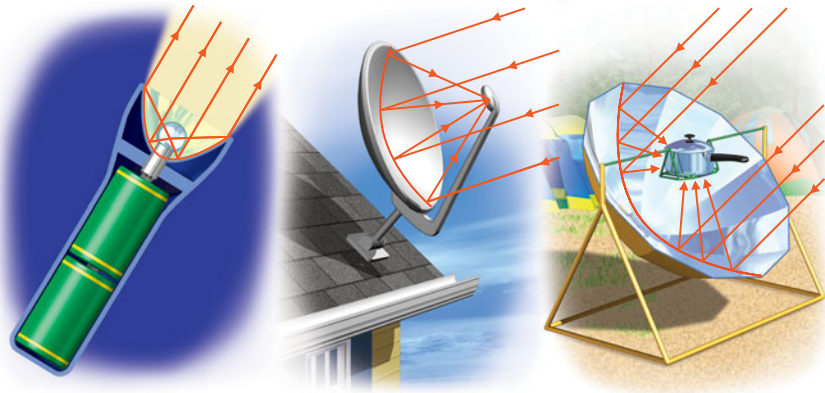

10.1 Exercise Set

In Exercises 1–6, match the equation with one of the graphs (a)–(f), which follow.

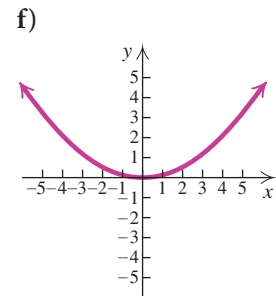
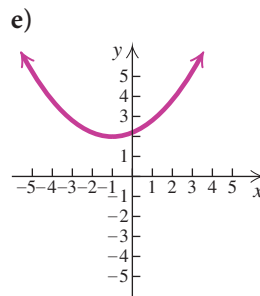
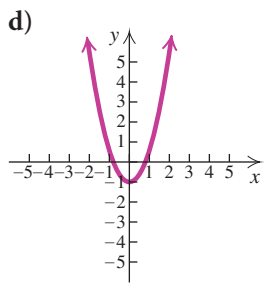
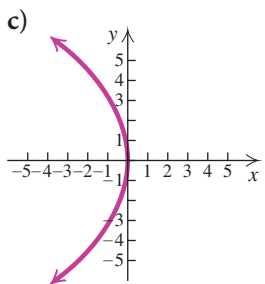
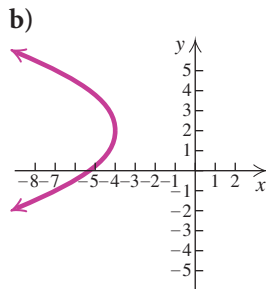
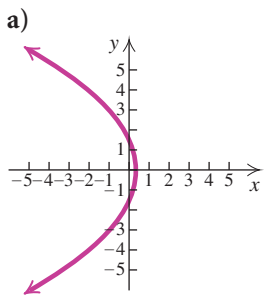

1. $x^2 = 8y$

2. $y^2 = -10x$

3. $(y - 2)^2 = -3(x + 4)$

4. $(x + 1)^2 = 5(y - 2)$

5. $13x^2 - 8y - 9 = 0$

6. $41x + 6y^2 = 12$

Find the vertex, the focus, and the directrix. Then draw the graph.

7. $x^2 = 20y$

8. $x^2 = 16y$

9. $y^2 = -6x$

10. $y^2 = -2x$

11. $x^2 - 4y = 0$ 12. $y^2 + 4x = 0$
 13. $x = 2y^2$ 14. $y = \frac{1}{2}x^2$

Find an equation of a parabola satisfying the given conditions.

15. Focus $(4, 0)$, directrix $x = -4$
 16. Focus $(0, \frac{1}{4})$, directrix $y = -\frac{1}{4}$
 17. Focus $(0, -\pi)$, directrix $y = \pi$
 18. Focus $(-\sqrt{2}, 0)$, directrix $x = \sqrt{2}$
 19. Focus $(3, 2)$, directrix $x = -4$
 20. Focus $(-2, 3)$, directrix $y = -3$

Find the vertex, the focus, and the directrix. Then draw the graph.

21. $(x + 2)^2 = -6(y - 1)$
 22. $(y - 3)^2 = -20(x + 2)$
 23. $x^2 + 2x + 2y + 7 = 0$
 24. $y^2 + 6y - x + 16 = 0$
 25. $x^2 - y - 2 = 0$ 26. $x^2 - 4x - 2y = 0$
 27. $y = x^2 + 4x + 3$ 28. $y = x^2 + 6x + 10$
 29. $y^2 - y - x + 6 = 0$ 30. $y^2 + y - x - 4 = 0$

31. **Satellite Dish.** An engineer designs a satellite dish with a parabolic cross section. The dish is 15 ft wide at the opening, and the focus is placed 4 ft from the vertex.

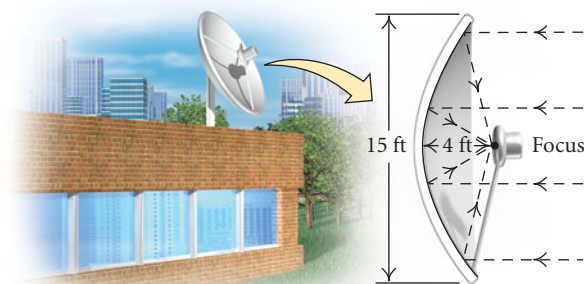

- a) Position a coordinate system with the origin at the vertex and the x -axis on the parabola's axis of symmetry and find an equation of the parabola.
 b) Find the depth of the satellite dish at the vertex.

32. **Flashlight Mirror.** A heavy-duty flashlight mirror has a parabolic cross section with diameter 6 in. and depth 1 in.

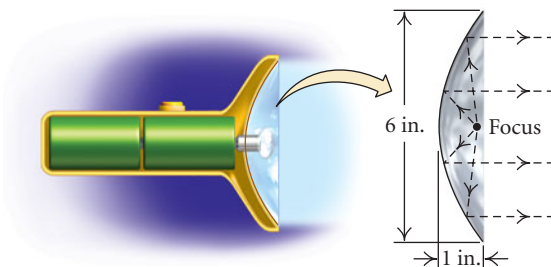

- a) Position a coordinate system with the origin at the vertex and the x -axis on the parabola's axis of symmetry and find an equation of the parabola.
 b) How far from the vertex should the bulb be positioned if it is to be placed at the focus?
33. **Spotlight.** A spotlight has a parabolic cross section that is 4 ft wide at the opening and 1.5 ft deep at the vertex. How far from the vertex is the focus?
34. **Field Microphone.** A field microphone used at a football game has a parabolic cross section and is 18 in. deep. The focus is 4 in. from the vertex. Find the width of the microphone at the opening.

Skill Maintenance

Consider the following linear equations. Without graphing them, answer the questions below.

- a) $y = 2x$ b) $y = \frac{1}{3}x + 5$
 c) $y = -3x - 2$ d) $y = -0.9x + 7$
 e) $y = -5x + 3$ f) $y = x + 4$
 g) $8x - 4y = 7$ h) $3x + 6y = 2$
35. Which has/have x -intercept $(\frac{2}{3}, 0)$?
36. Which has/have y -intercept $(0, 7)$?
37. Which slant up from left to right?
38. Which has the least steep slant?
39. Which has/have slope $\frac{1}{3}$?
40. Which, if any, contain the point $(3, 7)$?
41. Which, if any, are parallel?
42. Which, if any, are perpendicular?

Synthesis

43. Find an equation of the parabola with a vertical axis of symmetry and vertex $(-1, 2)$ and containing the point $(-3, 1)$.
44. Find an equation of a parabola with a horizontal axis of symmetry and vertex $(-2, 1)$ and containing the point $(-3, 5)$.
45. **Suspension Bridge.** The parabolic cables of a 200-ft portion of the roadbed of a suspension bridge are positioned as shown at right. Vertical cables are to be

spaced every 20 ft along this portion of the roadbed. Calculate the lengths of these vertical cables.

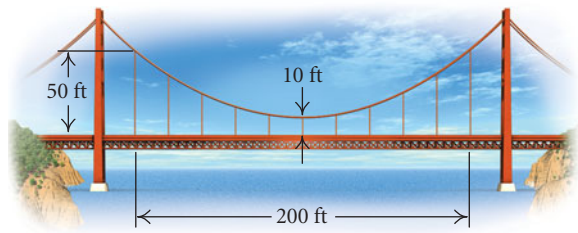

The Circle and the Ellipse

10.2

- ▶ Given an equation of a circle, complete the square, if necessary, and then find the center and the radius and graph the circle.
- ▶ Given an equation of an ellipse, complete the square, if necessary, and then find the center, the vertices, and the foci and graph the ellipse.

▶ Circles

We can define a circle geometrically.

Circle

A **circle** is the set of all points in a plane that are at a fixed distance from a fixed point (the **center**) in the plane.

Circles were introduced in Section 1.1. Recall the standard equation of a circle with center (h, k) and radius r .

Standard Equation of a Circle

The standard equation of a circle with center (h, k) and radius r is

$$(x - h)^2 + (y - k)^2 = r^2.$$

EXAMPLE 1 For the circle

$$x^2 + y^2 - 16x + 14y + 32 = 0,$$

find the center and the radius. Then graph the circle.

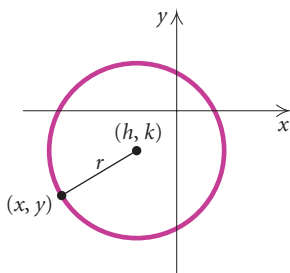
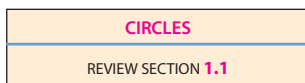

Solution First, we complete the square twice:

$$\begin{aligned}x^2 + y^2 - 16x + 14y + 32 &= 0 \\x^2 - 16x + y^2 + 14y &= -32 \\x^2 - 16x + 64 + y^2 + 14y + 49 &= -32 + 64 + 49 \\& \left[\frac{1}{2}(-16) \right]^2 = (-8)^2 = 64 \text{ and } \left(\frac{1}{2} \cdot 14 \right)^2 = 7^2 = 49; \\& \text{adding 64 and 49 on both sides to complete the square} \\& \text{twice on the left side}\end{aligned}$$

$$(x - 8)^2 + (y + 7)^2 = 81$$

$$(x - 8)^2 + [y - (-7)]^2 = 9^2. \quad \text{Writing standard form}$$

The center is $(8, -7)$ and the radius is 9. We graph the circle as shown below.

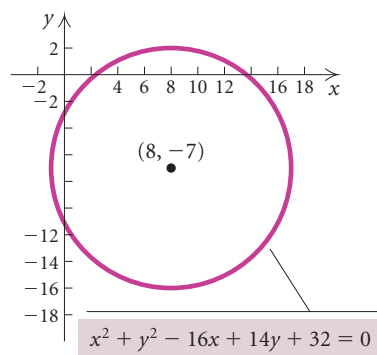

Now Try Exercise 7.

TECHNOLOGY CONNECTION

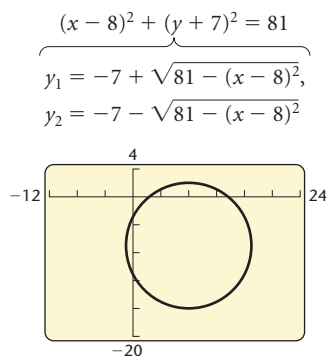

To use a graphing calculator to graph the circle in Example 1, it might be necessary to solve for y first. The original equation can be solved using the quadratic formula, or the standard form of the equation can be solved using the principle of square roots. The second alternative is illustrated here:

$$(x - 8)^2 + (y + 7)^2 = 81$$

$$(y + 7)^2 = 81 - (x - 8)^2$$

$$y + 7 = \pm \sqrt{81 - (x - 8)^2}$$

$$y = -7 \pm \sqrt{81 - (x - 8)^2}.$$

Using the principle of square roots

Then we graph

$$y_1 = -7 + \sqrt{81 - (x - 8)^2}$$

and

$$y_2 = -7 - \sqrt{81 - (x - 8)^2}$$

in a squared viewing window.

(Continued)

When we use the Conics CIRCLE APP to graph a circle, it is not necessary to write the equation in standard form or to solve it for y first. We enter the coefficients of x^2 , y^2 , x , and y and also the constant term when the equation is written in the form $ax^2 + ay^2 + bx + cy + d = 0$.

CIRCLE	
$AX^2+AY^2+BX+CY+D=0$	
A=	1
B=	-16
C=	14
D=	32
ESC	

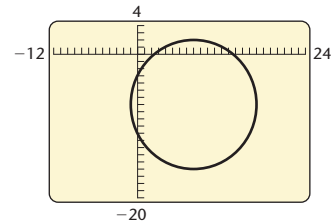

Some graphing calculators have a DRAW feature that provides a quick way to graph a circle when the center and the radius are known. This feature is described on p. 70.

► Ellipses

We have studied two conic sections, the parabola and the circle. Now we turn our attention to a third, the *ellipse*.

Ellipse

An **ellipse** is the set of all points in a plane, the sum of whose distances from two fixed points (the **foci**) is constant. The **center** of an ellipse is the midpoint of the segment between the foci.

We can draw an ellipse by first placing two thumbtacks in a piece of cardboard. These are the foci (singular, *focus*). We then attach a piece of string to the tacks. Its length is the constant sum of the distances $d_1 + d_2$ from the foci to any point on the ellipse. Next, we trace a curve with a pen held tight against the string. The figure traced is an ellipse.

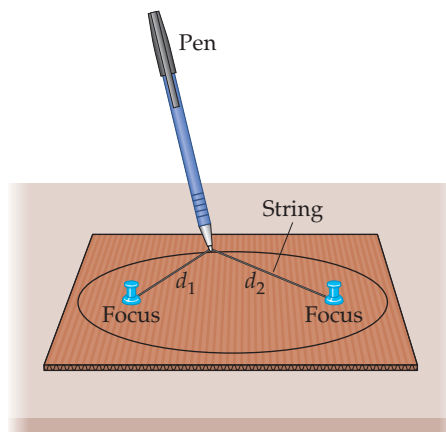

Let's first consider the ellipse shown below with center at the origin. The points F_1 and F_2 are the foci. The segment $\overline{A'A}$ is the **major axis**, and the points A' and A are the **vertices**. The segment $\overline{B'B}$ is the **minor axis**, and the points B' and B are the **y -intercepts**. Note that the major axis of an ellipse is longer than the minor axis.

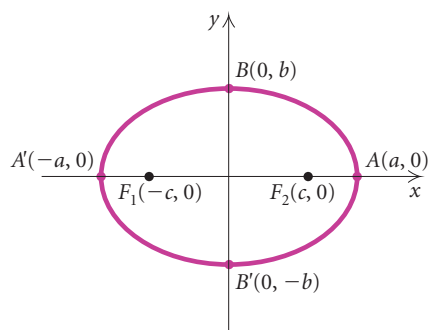

Standard Equation of an Ellipse with Center at the Origin

Major Axis Horizontal

$$\frac{x^2}{a^2} + \frac{y^2}{b^2} = 1, \quad a > b > 0$$

Vertices: $(-a, 0), (a, 0)$

y -intercepts: $(0, -b), (0, b)$

Foci: $(-c, 0), (c, 0)$, where $c^2 = a^2 - b^2$

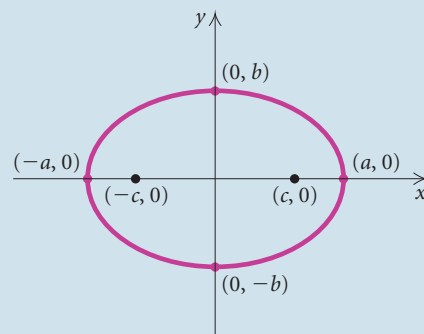

Major Axis Vertical

$$\frac{x^2}{b^2} + \frac{y^2}{a^2} = 1, \quad a > b > 0$$

Vertices: $(0, -a), (0, a)$

x -intercepts: $(-b, 0), (b, 0)$

Foci: $(0, -c), (0, c)$, where $c^2 = a^2 - b^2$

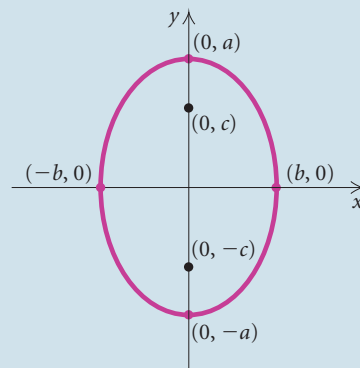

STUDY TIP

If you are finding it difficult to master a particular topic or concept, talk about it with a classmate. Verbalizing your questions about the material might help clarify it for you.

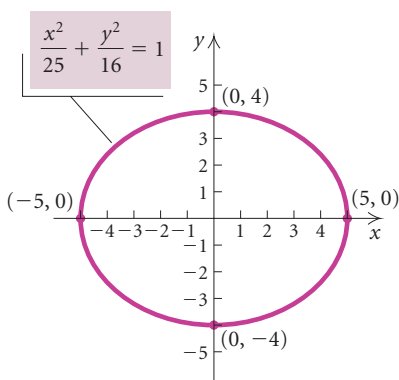

EXAMPLE 2 Find the standard equation of the ellipse with vertices $(-5, 0)$ and $(5, 0)$ and foci $(-3, 0)$ and $(3, 0)$. Then graph the ellipse.

Solution Since the foci are on the x -axis and the origin is the midpoint of the segment between them, the major axis is horizontal and $(0, 0)$ is the center of the ellipse. Thus the equation is of the form

$$\frac{x^2}{a^2} + \frac{y^2}{b^2} = 1.$$

Since the vertices are $(-5, 0)$ and $(5, 0)$ and the foci are $(-3, 0)$ and $(3, 0)$, we know that $a = 5$ and $c = 3$. These values can be used to find b^2 :

$$c^2 = a^2 - b^2$$

$$3^2 = 5^2 - b^2$$

$$9 = 25 - b^2$$

$$b^2 = 16.$$

Thus the equation of the ellipse is

$$\frac{x^2}{5^2} + \frac{y^2}{4^2} = 1, \quad \text{or} \quad \frac{x^2}{25} + \frac{y^2}{16} = 1.$$

To graph the ellipse, we plot the vertices $(-5, 0)$ and $(5, 0)$. Since $b^2 = 16$, we know that $b = 4$ and the y -intercepts are $(0, -4)$ and $(0, 4)$. We plot these points as well and connect the four points we have plotted with a smooth curve.

Now Try Exercise 31.

TECHNOLOGY CONNECTION

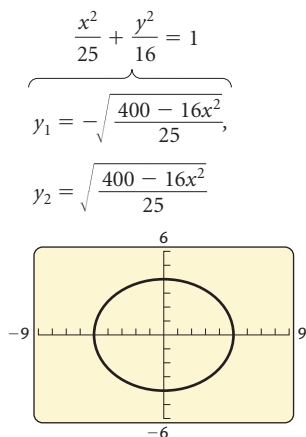

To draw the graph in Example 2 using a graphing calculator, it might be necessary to solve for y first:

$$y = \pm \sqrt{\frac{400 - 16x^2}{25}}.$$

Then we graph

$$y_1 = -\sqrt{\frac{400 - 16x^2}{25}} \quad \text{and} \quad y_2 = \sqrt{\frac{400 - 16x^2}{25}}$$

or

$$y_1 = -\sqrt{\frac{400 - 16x^2}{25}} \quad \text{and} \quad y_2 = -y_1$$

in a squared viewing window.

On some graphing calculators, the Conics application from the APPS menu can be used to graph ellipses.

EXAMPLE 3 For the ellipse

$$9x^2 + 4y^2 = 36,$$

find the vertices and the foci. Then draw the graph.

Solution We first find standard form:

$$9x^2 + 4y^2 = 36$$

$$\frac{9x^2}{36} + \frac{4y^2}{36} = \frac{36}{36}$$

$$\frac{x^2}{4} + \frac{y^2}{9} = 1$$

$$\frac{x^2}{2^2} + \frac{y^2}{3^2} = 1.$$

Dividing by 36 on both sides to get 1 on the right side

Writing standard form

Thus, $a = 3$ and $b = 2$. The major axis is vertical, so the vertices are $(0, -3)$ and $(0, 3)$. Since we know that $c^2 = a^2 - b^2$, we have $c^2 = 3^2 - 2^2 = 9 - 4 = 5$, so $c = \sqrt{5}$ and the foci are $(0, -\sqrt{5})$ and $(0, \sqrt{5})$.

To graph the ellipse, we plot the vertices. Note also that since $b = 2$, the x -intercepts are $(-2, 0)$ and $(2, 0)$. We plot these points as well and connect the four points we have plotted with a smooth curve.

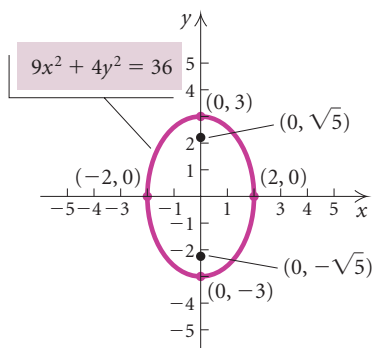

➔ Now Try Exercise 25.

If the center of an ellipse is not at the origin but at some point (h, k) , then we can think of an ellipse with center at the origin being translated horizontally $|h|$ units and vertically $|k|$ units.

Standard Equation of an Ellipse with Center at (h, k)

Major Axis Horizontal

$$\frac{(x - h)^2}{a^2} + \frac{(y - k)^2}{b^2} = 1, \quad a > b > 0$$

Vertices: $(h - a, k)$, $(h + a, k)$

Length of minor axis: $2b$

Foci: $(h - c, k)$, $(h + c, k)$, where $c^2 = a^2 - b^2$

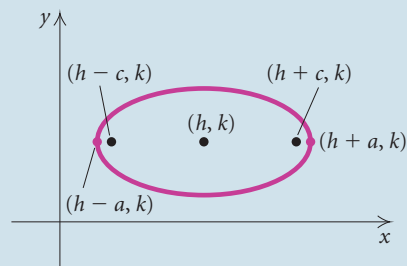

Major Axis Vertical

$$\frac{(x - h)^2}{b^2} + \frac{(y - k)^2}{a^2} = 1, \quad a > b > 0$$

Vertices: $(h, k - a)$, $(h, k + a)$

Length of minor axis: $2b$

Foci: $(h, k - c)$, $(h, k + c)$, where $c^2 = a^2 - b^2$

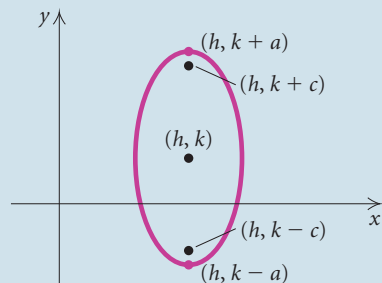

EXAMPLE 4 For the ellipse

$$4x^2 + y^2 + 24x - 2y + 21 = 0,$$

find the center, the vertices, and the foci. Then draw the graph.

Solution First, we complete the square twice to get standard form:

$$\begin{aligned} 4x^2 + y^2 + 24x - 2y + 21 &= 0 \\ 4(x^2 + 6x \quad) + (y^2 - 2y \quad) &= -21 \\ 4(x^2 + 6x + 9) + (y^2 - 2y + 1) &= -21 + 4 \cdot 9 + 1 \end{aligned}$$

Completing the square twice by adding $4 \cdot 9$ and 1 on both sides

$$\begin{aligned} 4(x + 3)^2 + (y - 1)^2 &= 16 \\ \frac{1}{16}[4(x + 3)^2 + (y - 1)^2] &= \frac{1}{16} \cdot 16 \end{aligned}$$

$$\frac{(x + 3)^2}{4} + \frac{(y - 1)^2}{16} = 1$$

$$\frac{[x - (-3)]^2}{2^2} + \frac{(y - 1)^2}{4^2} = 1.$$

Writing standard form:

$$\frac{(x - h)^2}{b^2} + \frac{(y - k)^2}{a^2} = 1$$

The center is $(-3, 1)$. Note that $a = 4$ and $b = 2$. The major axis is vertical, so the vertices are 4 units above and below the center:

$$(-3, 1 + 4) \text{ and } (-3, 1 - 4), \text{ or } (-3, 5) \text{ and } (-3, -3).$$

We know that $c^2 = a^2 - b^2$, so $c^2 = 4^2 - 2^2 = 16 - 4 = 12$ and $c = \sqrt{12}$, or $2\sqrt{3}$. Then the foci are $2\sqrt{3}$ units above and below the center:

$$(-3, 1 + 2\sqrt{3}) \text{ and } (-3, 1 - 2\sqrt{3}).$$

To graph the ellipse, we plot the vertices. Note also that since $b = 2$, two other points on the graph are the endpoints of the minor axis, 2 units right and left of the center:

$$(-3 + 2, 1) \text{ and } (-3 - 2, 1),$$

or

$$(-1, 1) \text{ and } (-5, 1).$$

We plot these points as well and connect the four points with a smooth curve.

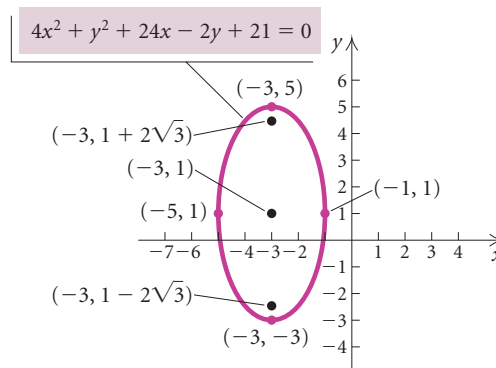

► Applications

An exciting medical application of an ellipse is a device called a *lithotripter*. One type of this device uses electromagnetic technology to generate a shock wave to pulverize kidney stones. The wave originates at one focus of an ellipse and is reflected to the kidney stone, which is positioned at the other focus. Recovery time following the use of this technique is much shorter than with conventional surgery and the mortality rate is far lower.

Ellipses have many other applications. Planets travel around the sun in elliptical orbits with the sun at one focus, for example, and satellites travel around the earth in elliptical orbits as well.

A room with an ellipsoidal ceiling is known as a *whispering gallery*. In such a room, a word whispered at one focus can be clearly heard at the other. Whispering galleries are found in the rotunda of the Capitol Building in Washington, D.C., and in St. Paul's Cathedral in London.



Lithotripter

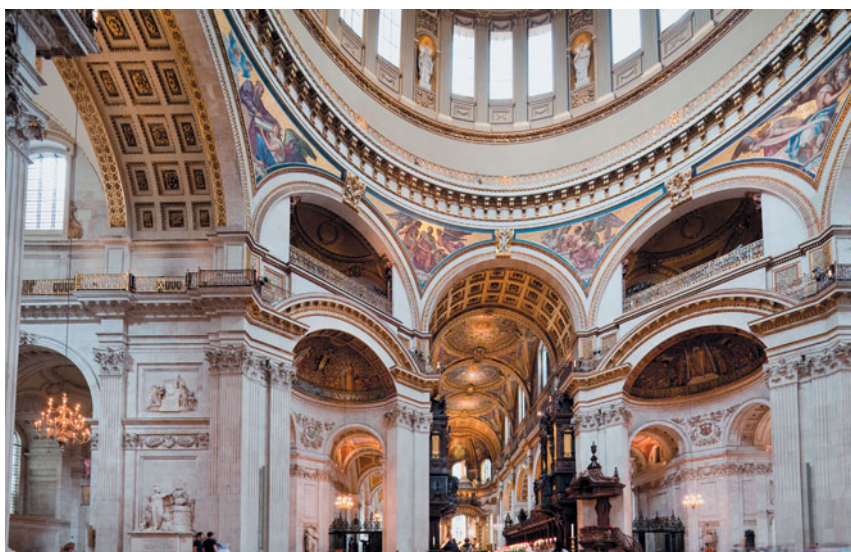
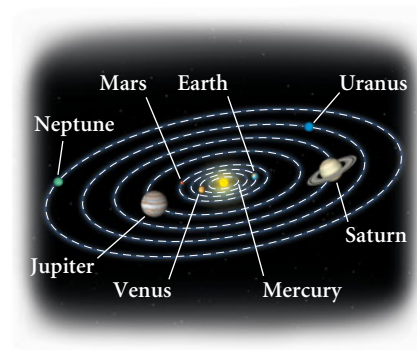

10.2

Exercise Set

In Exercises 1–6, match the equation with one of the graphs (a)–(f), which follow.

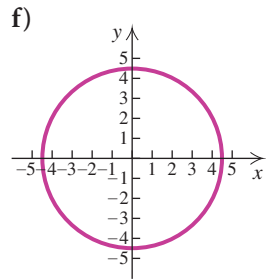
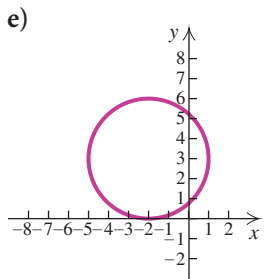
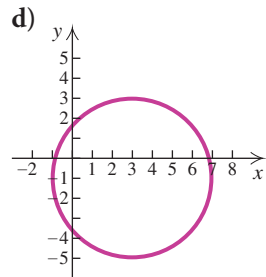
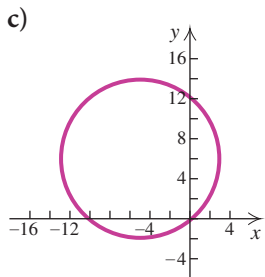
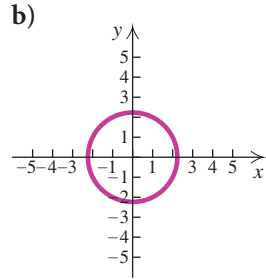
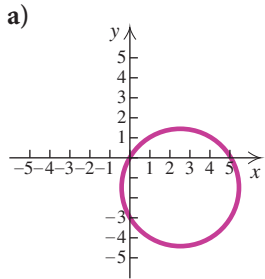

1. $x^2 + y^2 = 5$

2. $y^2 = 20 - x^2$

3. $x^2 + y^2 - 6x + 2y = 6$

4. $x^2 + y^2 + 10x - 12y = 3$

5. $x^2 + y^2 - 5x + 3y = 0$

6. $x^2 + 4x - 2 = 6y - y^2 - 6$

Find the center and the radius of the circle with the given equation. Then draw the graph.

7. $x^2 + y^2 - 14x + 4y = 11$

8. $x^2 + y^2 + 2x - 6y = -6$

9. $x^2 + y^2 + 6x - 2y = 6$

10. $x^2 + y^2 - 4x + 2y = 4$

11. $x^2 + y^2 + 4x - 6y - 12 = 0$

12. $x^2 + y^2 - 8x - 2y - 19 = 0$

13. $x^2 + y^2 - 6x - 8y + 16 = 0$

14. $x^2 + y^2 - 2x + 6y + 1 = 0$

15. $x^2 + y^2 + 6x - 10y = 0$

16. $x^2 + y^2 - 7x - 2y = 0$

17. $x^2 + y^2 - 9x = 7 - 4y$

18. $y^2 - 6y - 1 = 8x - x^2 + 3$

In Exercises 19–22, match the equation with one of the graphs (a)–(d), which follow.

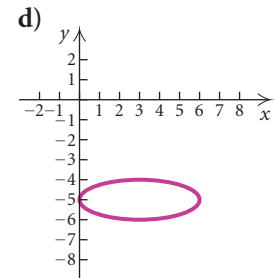
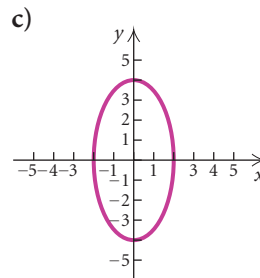
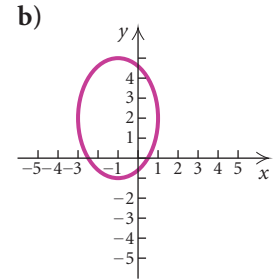
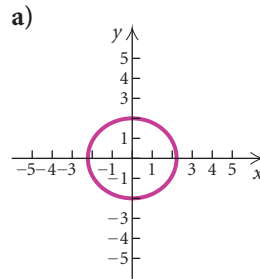

19. $16x^2 + 4y^2 = 64$

20. $4x^2 + 5y^2 = 20$

21. $x^2 + 9y^2 - 6x + 90y = -225$

22. $9x^2 + 4y^2 + 18x - 16y = 11$

Find the vertices and the foci of the ellipse with the given equation. Then draw the graph.

23. $\frac{x^2}{4} + \frac{y^2}{1} = 1$

24. $\frac{x^2}{25} + \frac{y^2}{36} = 1$

25. $16x^2 + 9y^2 = 144$
 26. $9x^2 + 4y^2 = 36$
 27. $2x^2 + 3y^2 = 6$
 28. $5x^2 + 7y^2 = 35$
 29. $4x^2 + 9y^2 = 1$
 30. $25x^2 + 16y^2 = 1$

Find an equation of an ellipse satisfying the given conditions.

31. Vertices: $(-7, 0)$ and $(7, 0)$;
 foci: $(-3, 0)$ and $(3, 0)$
 32. Vertices: $(0, -6)$ and $(0, 6)$;
 foci: $(0, -4)$ and $(0, 4)$
 33. Vertices: $(0, -8)$ and $(0, 8)$;
 length of minor axis: 10
 34. Vertices: $(-5, 0)$ and $(5, 0)$;
 length of minor axis: 6
 35. Foci: $(-2, 0)$ and $(2, 0)$;
 length of major axis: 6
 36. Foci: $(0, -3)$ and $(0, 3)$;
 length of major axis: 10

Find the center, the vertices, and the foci of the ellipse. Then draw the graph.

37. $\frac{(x-1)^2}{9} + \frac{(y-2)^2}{4} = 1$
 38. $\frac{(x-1)^2}{1} + \frac{(y-2)^2}{4} = 1$
 39. $\frac{(x+3)^2}{25} + \frac{(y-5)^2}{36} = 1$
 40. $\frac{(x-2)^2}{16} + \frac{(y+3)^2}{25} = 1$
 41. $3(x+2)^2 + 4(y-1)^2 = 192$
 42. $4(x-5)^2 + 3(y-4)^2 = 48$
 43. $4x^2 + 9y^2 - 16x + 18y - 11 = 0$
 44. $x^2 + 2y^2 - 10x + 8y + 29 = 0$
 45. $4x^2 + y^2 - 8x - 2y + 1 = 0$
 46. $9x^2 + 4y^2 + 54x - 8y + 49 = 0$

The **eccentricity** of an ellipse is defined as $e = c/a$. For an ellipse, $0 < c < a$, so $0 < e < 1$. When e is close to 0, an ellipse appears to be nearly circular. When e is close to 1, an ellipse is very flat.

47. Note the shapes of the ellipses in Examples 2 and 4. Which ellipse has the smaller eccentricity? Confirm your answer by computing the eccentricity of each ellipse.
 48. Which ellipse has the smaller eccentricity? (Assume that the coordinate systems have the same scale.)

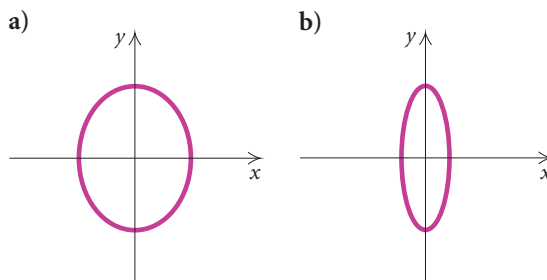

49. Find an equation of an ellipse with vertices $(0, -4)$ and $(0, 4)$ and $e = \frac{1}{4}$.
 50. Find an equation of an ellipse with vertices $(-3, 0)$ and $(3, 0)$ and $e = \frac{7}{10}$.
 51. **Bridge Supports.** The bridge support shown in the figure below is the top half of an ellipse. Assuming that a coordinate system is superimposed on the drawing in such a way that point Q, the center of the ellipse, is at the origin, find an equation of the ellipse.

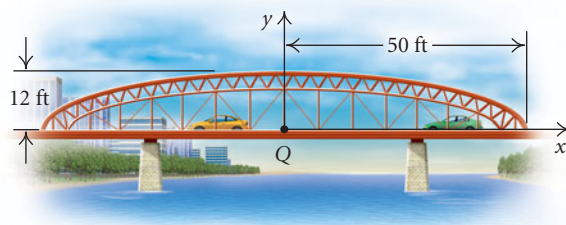

52. **The Ellipse.** In Washington, D.C., there is a large grassy area south of the White House known as the Ellipse. It is actually an ellipse with major axis of length 1048 ft and minor axis of length 898 ft. Assuming that a coordinate system is superimposed on the area in such a way that the center is at the origin and the major and minor axes are on the x - and y -axes of the coordinate system, respectively, find an equation of the ellipse.

53. **The Earth's Orbit.** The maximum distance of the earth from the sun is 9.3×10^7 mi. The minimum distance is 9.1×10^7 mi. The sun is at one focus of the elliptical orbit. Find the distance from the sun to the other focus.
54. **Carpentry.** A carpenter is cutting a 3-ft by 4-ft elliptical sign from a 3-ft by 4-ft piece of plywood. The ellipse will be drawn using a string attached to the board at the foci of the ellipse.

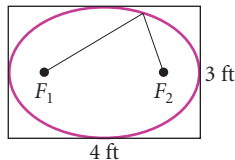

- a) How far from the ends of the board should the string be attached?
 b) How long should the string be?

Skill Maintenance

In each of Exercises 55–62, fill in the blank with the correct term. Some of the given choices will not be used.

piecewise function
 linear equation
 factor
 remainder
 solution
 zero
 x -intercept
 y -intercept
 parabola
 circle
 ellipse
 midpoint
 distance
 one real-number solution
 two different real-number solutions
 two different imaginary-number solutions

55. The _____ between two points (x_1, y_1) and (x_2, y_2) is given by $\left(\frac{x_1 + x_2}{2}, \frac{y_1 + y_2}{2}\right)$.
56. An input c of a function f is a(n) _____ of the function if $f(c) = 0$.
57. A(n) _____ of the graph of an equation is a point $(0, b)$.

58. For a quadratic equation $ax^2 + bx + c = 0$, if $b^2 - 4ac > 0$, the equation has _____.
59. Given a polynomial $f(x)$, then $f(c)$ is the _____ that would be obtained by dividing $f(x)$ by $x - c$.
60. A(n) _____ is the set of all points in a plane the sum of whose distances from two fixed points is constant.
61. A(n) _____ is the set of all points in a plane equidistant from a fixed line and a fixed point not on the line.
62. A(n) _____ is the set of all points in a plane that are at a fixed distance from a fixed point in the plane.

Synthesis

Find an equation of an ellipse satisfying the given conditions.

63. Vertices: $(3, -4)$, $(3, 6)$;
 endpoints of minor axis: $(1, 1)$, $(5, 1)$
64. Vertices: $(-1, -1)$, $(-1, 5)$;
 endpoints of minor axis: $(-3, 2)$, $(1, 2)$
65. Vertices: $(-3, 0)$ and $(3, 0)$;
 passing through $\left(2, \frac{22}{3}\right)$
66. Center: $(-2, 3)$; major axis vertical;
 length of major axis: 4;
 length of minor axis: 1
67. **Bridge Arch.** A bridge with a semielliptical arch spans a river as shown here. What is the clearance 6 ft from the riverbank?

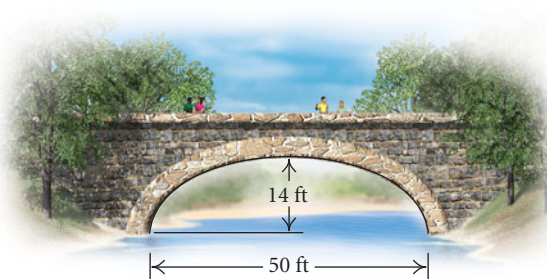

The Hyperbola

10.3

- Given an equation of a hyperbola, complete the square, if necessary, and then find the center, the vertices, and the foci and graph the hyperbola.

The last type of conic section that we will study is the *hyperbola*.

Hyperbola

A **hyperbola** is the set of all points in a plane for which the absolute value of the difference of the distances from two fixed points (the **foci**) is constant. The midpoint of the segment between the foci is the **center** of the hyperbola.

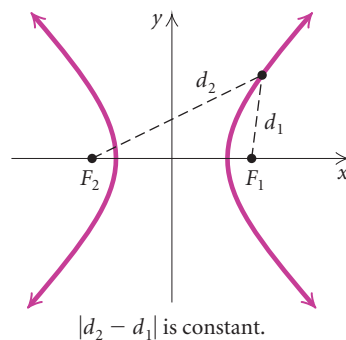

► Standard Equations of Hyperbolas

We first consider the equation of a hyperbola with center at the origin. In the figure at right, F_1 and F_2 are the foci. The segment $\overline{V_2V_1}$ is the **transverse axis** and the points V_2 and V_1 are the **vertices**.

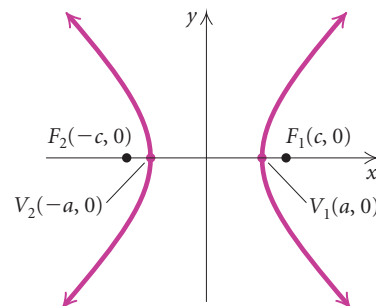

Standard Equation of a Hyperbola with Center at the Origin

Transverse Axis Horizontal

$$\frac{x^2}{a^2} - \frac{y^2}{b^2} = 1$$

Vertices: $(-a, 0)$, $(a, 0)$

Foci: $(-c, 0)$, $(c, 0)$,

where $c^2 = a^2 + b^2$

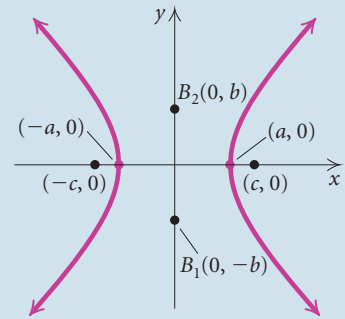

Transverse Axis Vertical

$$\frac{y^2}{a^2} - \frac{x^2}{b^2} = 1$$

Vertices: $(0, -a)$, $(0, a)$

Foci: $(0, -c)$, $(0, c)$,

where $c^2 = a^2 + b^2$

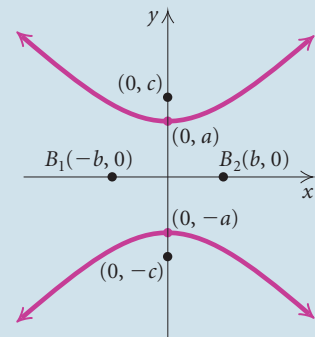

The segment $\overline{B_1B_2}$ is the **conjugate axis** of the hyperbola.

To graph a hyperbola with a horizontal transverse axis, it is helpful to begin by graphing the lines $y = -(b/a)x$ and $y = (b/a)x$. These are the **asymptotes** of the hyperbola. For a hyperbola with a vertical transverse axis, the asymptotes are $y = -(a/b)x$ and $y = (a/b)x$. As $|x|$ gets larger and larger, the graph of the hyperbola gets closer and closer to the asymptotes.

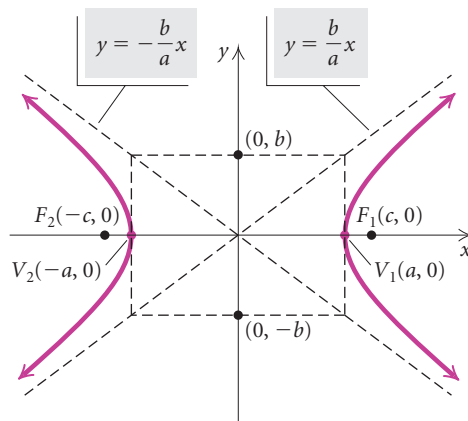

STUDY TIP

Take the time to include all the steps when working your homework problems. Doing so will help you organize your thinking and avoid computational errors. It will also give you complete, step-by-step solutions of the exercises that can be used to study for an exam.

EXAMPLE 1 Find an equation of the hyperbola with vertices $(0, -4)$ and $(0, 4)$ and foci $(0, -6)$ and $(0, 6)$.

Solution We know that $a = 4$ and $c = 6$. We find b^2 :

$$c^2 = a^2 + b^2$$

$$6^2 = 4^2 + b^2$$

$$36 = 16 + b^2$$

$$20 = b^2.$$

Since the vertices and the foci are on the y -axis, we know that the transverse axis is vertical. We can now write the equation of the hyperbola:

$$\frac{y^2}{a^2} - \frac{x^2}{b^2} = 1$$

$$\frac{y^2}{16} - \frac{x^2}{20} = 1.$$

 **Now Try Exercise 7.**

EXAMPLE 2 For the hyperbola given by

$$9x^2 - 16y^2 = 144,$$

find the vertices, the foci, and the asymptotes. Then graph the hyperbola.

Solution First, we find standard form:

$$9x^2 - 16y^2 = 144$$

$$\frac{1}{144}(9x^2 - 16y^2) = \frac{1}{144} \cdot 144$$

Multiplying by $\frac{1}{144}$ to get 1 on the right side

$$\frac{x^2}{16} - \frac{y^2}{9} = 1$$

$$\frac{x^2}{4^2} - \frac{y^2}{3^2} = 1.$$

Writing standard form

The hyperbola has a horizontal transverse axis, so the vertices are $(-a, 0)$ and $(a, 0)$, or $(-4, 0)$ and $(4, 0)$. From the standard form of the equation, we know that $a^2 = 4^2$, or 16, and $b^2 = 3^2$, or 9. We find the foci:

$$c^2 = a^2 + b^2$$

$$c^2 = 16 + 9$$

$$c^2 = 25$$

$$c = 5.$$

Thus the foci are $(-5, 0)$ and $(5, 0)$.

Next, we find the asymptotes:

$$y = -\frac{b}{a}x = -\frac{3}{4}x \quad \text{and} \quad y = \frac{b}{a}x = \frac{3}{4}x.$$

To draw the graph, we sketch the asymptotes first. This is easily done by drawing the rectangle with horizontal sides passing through $(0, 3)$ and $(0, -3)$ and vertical sides through $(4, 0)$ and $(-4, 0)$. Then we draw and extend the diagonals of this rectangle. The two extended diagonals are the asymptotes of the hyperbola. Next, we plot the vertices and draw the branches of the hyperbola outward from the vertices toward the asymptotes.

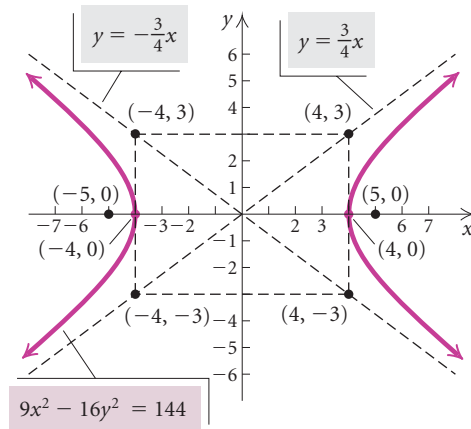

➔ Now Try Exercise 17.

TECHNOLOGY CONNECTION

To graph the hyperbola in Example 2 on a graphing calculator, it might be necessary to solve for y first and then graph the top and bottom halves of the hyperbola in the same squared viewing window.

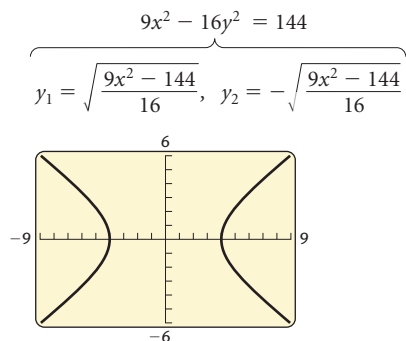

On some graphing calculators, the Conics HYPERBOLA APP can be used to graph hyperbolas.

If a hyperbola with center at the origin is translated horizontally $|h|$ units and vertically $|k|$ units, the center is at the point (h, k) .

Standard Equation of a Hyperbola with Center at (h, k)

Transverse Axis Horizontal

$$\frac{(x - h)^2}{a^2} - \frac{(y - k)^2}{b^2} = 1$$

Vertices: $(h - a, k)$, $(h + a, k)$

Asymptotes: $y - k = \frac{b}{a}(x - h)$, $y - k = -\frac{b}{a}(x - h)$

Foci: $(h - c, k)$, $(h + c, k)$, where $c^2 = a^2 + b^2$

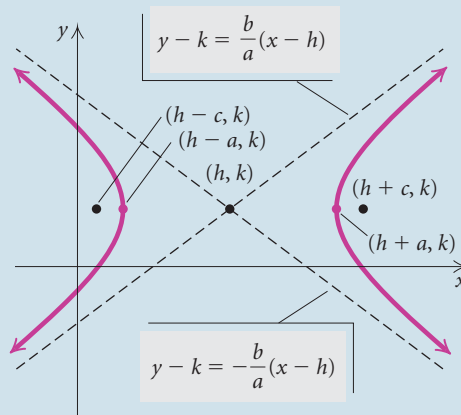

Transverse Axis Vertical

$$\frac{(y - k)^2}{a^2} - \frac{(x - h)^2}{b^2} = 1$$

Vertices: $(h, k - a)$, $(h, k + a)$

Asymptotes: $y - k = \frac{a}{b}(x - h)$, $y - k = -\frac{a}{b}(x - h)$

Foci: $(h, k - c)$, $(h, k + c)$, where $c^2 = a^2 + b^2$

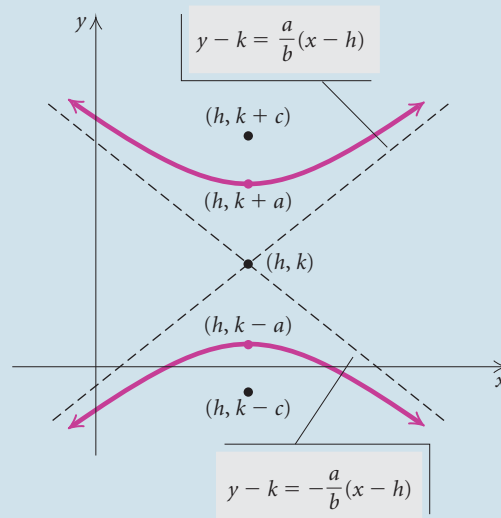

EXAMPLE 3 For the hyperbola given by

$$4y^2 - x^2 + 24y + 4x + 28 = 0,$$

find the center, the vertices, the foci, and the asymptotes. Then draw the graph.

Solution First, we complete the square to get standard form:

$$\begin{aligned}
 4y^2 - x^2 + 24y + 4x + 28 &= 0 \\
 4(y^2 + 6y \quad \quad) - (x^2 - 4x \quad \quad) &= -28 \\
 4(y^2 + 6y + 9 - 9) - (x^2 - 4x + 4 - 4) &= -28 \\
 4(y^2 + 6y + 9) + 4(-9) - (x^2 - 4x + 4) - (-4) &= -28 \\
 4(y^2 + 6y + 9) - 36 - (x^2 - 4x + 4) + 4 &= -28 \\
 4(y^2 + 6y + 9) - (x^2 - 4x + 4) &= -28 + 36 - 4 \\
 4(y + 3)^2 - (x - 2)^2 &= 4 \\
 \frac{(y + 3)^2}{1} - \frac{(x - 2)^2}{4} &= 1 \quad \text{Dividing by 4} \\
 \frac{[y - (-3)]^2}{1^2} - \frac{(x - 2)^2}{2^2} &= 1. \quad \text{Standard form}
 \end{aligned}$$

The center is $(2, -3)$. Note that $a = 1$ and $b = 2$. The transverse axis is vertical, so the vertices are 1 unit below and above the center:

$$(2, -3 - 1) \text{ and } (2, -3 + 1), \text{ or } (2, -4) \text{ and } (2, -2).$$

We know that $c^2 = a^2 + b^2$, so $c^2 = 1^2 + 2^2 = 1 + 4 = 5$ and $c = \sqrt{5}$. Thus the foci are $\sqrt{5}$ units below and above the center:

$$(2, -3 - \sqrt{5}) \text{ and } (2, -3 + \sqrt{5}).$$

The asymptotes are

$$y - (-3) = \frac{1}{2}(x - 2) \quad \text{and} \quad y - (-3) = -\frac{1}{2}(x - 2),$$

or

$$y + 3 = \frac{1}{2}(x - 2) \quad \text{and} \quad y + 3 = -\frac{1}{2}(x - 2).$$

We sketch the asymptotes, plot the vertices, and draw the graph.

TECHNOLOGY CONNECTION

When the equation of a hyperbola is written in standard form, we can use the Conics HYPERBOLA APP to graph it. The hyperbola in Example 3 is shown below.

HYPERBOLA

$$\frac{(Y-K)^2}{A^2} - \frac{(X-H)^2}{B^2} = 1$$

A=1
B=2
H=2
K=-3
ESC

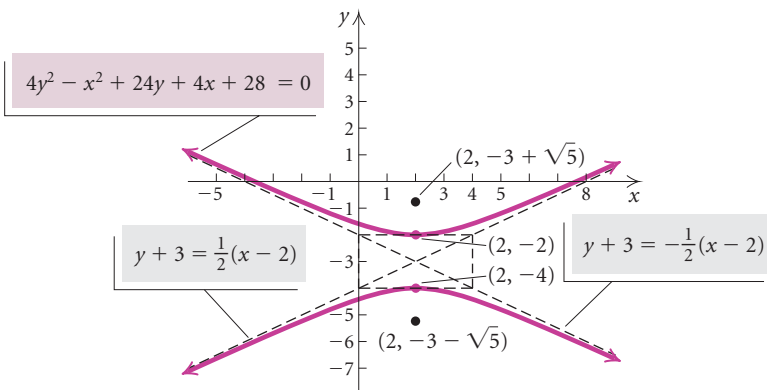
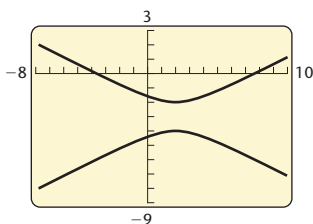

Now Try Exercise 29.

CONNECTING THE CONCEPTS

Classifying Equations of Conic Sections

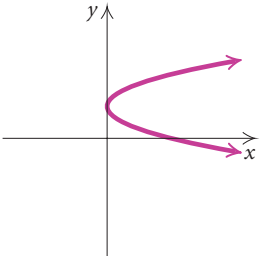
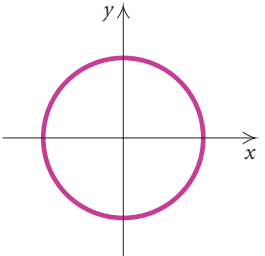
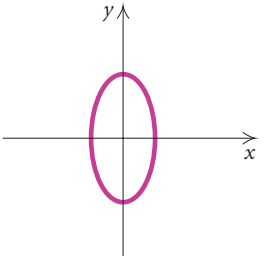
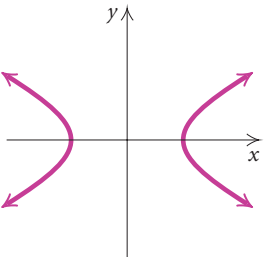
EQUATION	TYPE OF CONIC SECTION	GRAPH
$x - 4 + 4y = y^2$	Only one variable is squared, so this cannot be a circle, an ellipse, or a hyperbola. Find an equivalent equation: $x = (y - 2)^2.$ This is an equation of a parabola.	
$3x^2 + 3y^2 = 75$	Both variables are squared, so this cannot be a parabola. The squared terms are added, so this cannot be a hyperbola. Divide by 3 on both sides to find an equivalent equation: $x^2 + y^2 = 25.$ This is an equation of a circle.	
$y^2 = 16 - 4x^2$	Both variables are squared, so this cannot be a parabola. Add $4x^2$ on both sides to find an equivalent equation: $4x^2 + y^2 = 16.$ The squared terms are added, so this cannot be a hyperbola. The coefficients of x^2 and y^2 are not the same, so this is not a circle. Divide by 16 on both sides to find an equivalent equation: $\frac{x^2}{4} + \frac{y^2}{16} = 1.$ This is an equation of an ellipse.	
$x^2 = 4y^2 + 36$	Both variables are squared, so this cannot be a parabola. Subtract $4y^2$ on both sides to find an equivalent equation: $x^2 - 4y^2 = 36.$ The squared terms are not added, so this cannot be a circle or an ellipse. Divide by 36 on both sides to find an equivalent equation: $\frac{x^2}{36} - \frac{y^2}{9} = 1.$ This is an equation of a hyperbola.	

► Applications

Some comets travel in hyperbolic paths with the sun at one focus. Such comets pass by the sun only one time, unlike those with elliptical orbits, which reappear at intervals. We also see hyperbolas in architecture, such as in a cross section of a planetarium, an amphitheater, or a cooling tower for a steam or nuclear power plant.



Another application of hyperbolas is in the long-range navigation system LORAN. This system uses transmitting stations in three locations to send out simultaneous signals to a ship or aircraft. The difference in the arrival times of the signals from one pair of transmitters is recorded on the ship or aircraft. This difference is also recorded for signals from another pair of transmitters. For each pair, a computation is performed to determine the difference in the distances from each member of the pair to the ship or aircraft. If each pair of differences is kept constant, two hyperbolas can be drawn. Each has one of the pairs of transmitters as foci, and the ship or aircraft lies on the intersection of two of their branches.

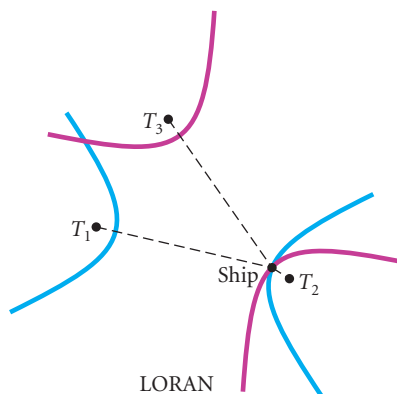

10.3

Exercise Set

In Exercises 1–6, match the equation with one of the graphs (a)–(f), which follow.

a)

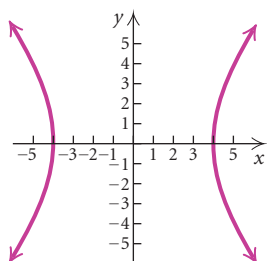

b)

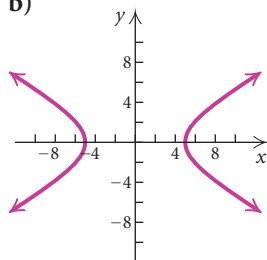

c)

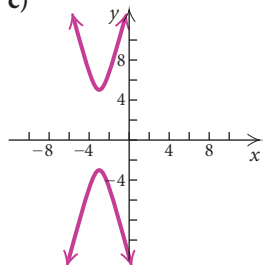

d)

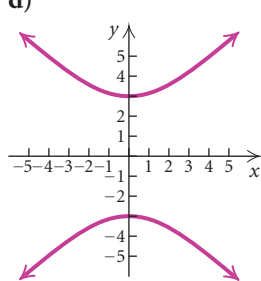

e)

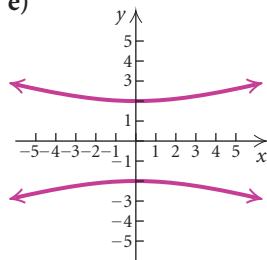

f)

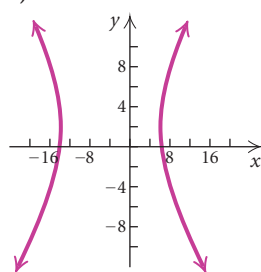

1. $\frac{x^2}{25} - \frac{y^2}{9} = 1$

2. $\frac{y^2}{4} - \frac{x^2}{36} = 1$

3. $\frac{(y-1)^2}{16} - \frac{(x+3)^2}{1} = 1$

4. $\frac{(x+4)^2}{100} - \frac{(y-2)^2}{81} = 1$

5. $25x^2 - 16y^2 = 400$

6. $y^2 - x^2 = 9$

Find an equation of a hyperbola satisfying the given conditions.

7. Vertices at $(0, 3)$ and $(0, -3)$;
foci at $(0, 5)$ and $(0, -5)$

8. Vertices at $(1, 0)$ and $(-1, 0)$;
foci at $(2, 0)$ and $(-2, 0)$

9. Asymptotes $y = \frac{3}{2}x$, $y = -\frac{3}{2}x$;
one vertex $(2, 0)$

10. Asymptotes $y = \frac{5}{4}x$, $y = -\frac{5}{4}x$;
one vertex $(0, 3)$

Find the center, the vertices, the foci, and the asymptotes. Then draw the graph.

11. $\frac{x^2}{4} - \frac{y^2}{4} = 1$

12. $\frac{x^2}{1} - \frac{y^2}{9} = 1$

13. $\frac{(x-2)^2}{9} - \frac{(y+5)^2}{1} = 1$

14. $\frac{(x-5)^2}{16} - \frac{(y+2)^2}{9} = 1$

15. $\frac{(y+3)^2}{4} - \frac{(x+1)^2}{16} = 1$

16. $\frac{(y+4)^2}{25} - \frac{(x+2)^2}{16} = 1$

17. $x^2 - 4y^2 = 4$

18. $4x^2 - y^2 = 16$

19. $9y^2 - x^2 = 81$

20. $y^2 - 4x^2 = 4$

21. $x^2 - y^2 = 2$

22. $x^2 - y^2 = 3$

23. $y^2 - x^2 = \frac{1}{4}$

24. $y^2 - x^2 = \frac{1}{9}$

Find the center, the vertices, the foci, and the asymptotes of the hyperbola. Then draw the graph.

25. $x^2 - y^2 - 2x - 4y - 4 = 0$

26. $4x^2 - y^2 + 8x - 4y - 4 = 0$

27. $36x^2 - y^2 - 24x + 6y - 41 = 0$

28. $9x^2 - 4y^2 + 54x + 8y + 41 = 0$

29. $9y^2 - 4x^2 - 18y + 24x - 63 = 0$
30. $x^2 - 25y^2 + 6x - 50y = 41$
31. $x^2 - y^2 - 2x - 4y = 4$
32. $9y^2 - 4x^2 - 54y - 8x + 41 = 0$
33. $y^2 - x^2 - 6x - 8y - 29 = 0$
34. $x^2 - y^2 = 8x - 2y - 13$

The **eccentricity** of a hyperbola is defined as $e = c/a$. For a hyperbola, $c > a > 0$, so $e > 1$. When e is close to 1, a hyperbola appears to be very narrow. As the eccentricity increases, the hyperbola becomes “wider.”

35. Note the shapes of the hyperbolas in Examples 2 and 3. Which hyperbola has the larger eccentricity? Confirm your answer by computing the eccentricity of each hyperbola.
36. Which hyperbola has the larger eccentricity? (Assume that the coordinate systems have the same scale.)

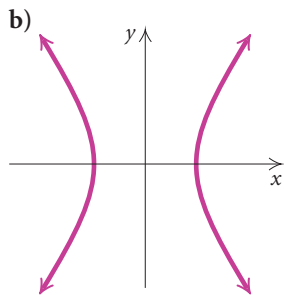
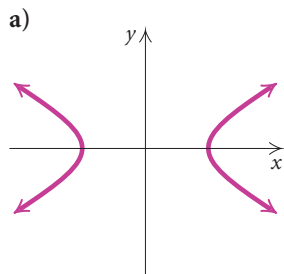

37. Find an equation of a hyperbola with vertices $(3, 7)$ and $(-3, 7)$ and $e = \frac{5}{3}$.
38. Find an equation of a hyperbola with vertices $(-1, 3)$ and $(-1, 7)$ and $e = 4$.
39. **Hyperbolic Mirror.** Certain telescopes contain both a parabolic mirror and a hyperbolic mirror. In the telescope shown in the figure, the parabola and the hyperbola share focus F_1 , which is 14 m above the vertex of the parabola. The hyperbola’s second focus F_2 is 2 m above the parabola’s vertex. The vertex of the hyperbolic mirror is 1 m below F_1 . Position a coordinate system with the origin at the

center of the hyperbola and with the foci on the y -axis. Then find the equation of the hyperbola.

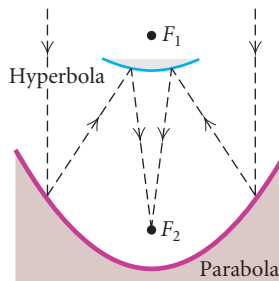

40. **Nuclear Cooling Tower.** A cross section of a nuclear cooling tower is a hyperbola with equation

$$\frac{x^2}{90^2} - \frac{y^2}{130^2} = 1.$$

The tower is 450 ft tall and the distance from the top of the tower to the center of the hyperbola is half the distance from the base of the tower to the center of the hyperbola. Find the diameter of the top and the base of the tower.

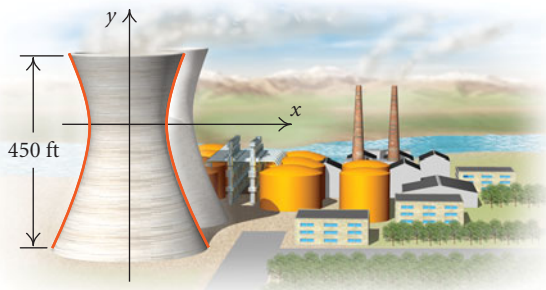

Skill Maintenance

In Exercises 41–44, given the function:

- a) Determine whether it is one-to-one.
 - b) If it is one-to-one, find a formula for the inverse.
41. $f(x) = 2x - 3$
 42. $f(x) = x^3 + 2$
 43. $f(x) = \frac{5}{x - 1}$
 44. $f(x) = \sqrt{x + 4}$

Solve.

45. $x + y = 5,$
 $x - y = 7$
46. $3x - 2y = 5,$
 $5x + 2y = 3$
47. $2x - 3y = 7,$
 $3x + 5y = 1$
48. $3x + 2y = -1,$
 $2x + 3y = 6$

Synthesis

Find an equation of a hyperbola satisfying the given conditions.

49. Vertices at $(3, -8)$ and $(3, -2)$;
asymptotes $y = 3x - 14$, $y = -3x + 4$
50. Vertices at $(-9, 4)$ and $(-5, 4)$;
asymptotes $y = 3x + 25$, $y = -3x - 17$
51. **Navigation.** Two radio transmitters positioned 300 mi apart along the shore send simultaneous signals to a ship that is 200 mi offshore, sailing parallel to the shoreline. The signal from transmitter S reaches the ship 200 microseconds later than the signal from transmitter T . The signals travel at a speed of 186,000 miles per second, or 0.186 mile

per microsecond. Find the equation of the hyperbola with foci S and T on which the ship is located. (Hint: For any point on the hyperbola, the absolute value of the difference of its distances from the foci is $2a$.)

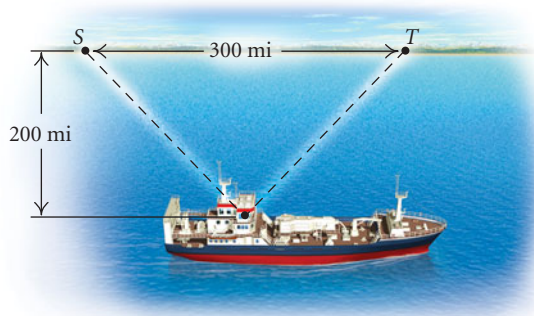

Nonlinear Systems of Equations and Inequalities

10.4

- ▶ Solve a nonlinear system of equations.
- ▶ Use nonlinear systems of equations to solve applied problems.
- ▶ Graph nonlinear systems of inequalities.

The systems of equations that we have studied so far have been composed of linear equations. Now we consider systems of two equations in two variables in which at least one equation is not linear.

▶ Nonlinear Systems of Equations

The graphs of the equations in a nonlinear system of equations can have no point of intersection or one or more points of intersection. The coordinates of each point of intersection represent a solution of the system of equations. When no point of intersection exists, the system of equations has no real-number solution.

Solutions of nonlinear systems of equations can be found using the substitution method or the elimination method. The substitution method is preferable for a system consisting of one linear equation and one nonlinear equation. The elimination method is preferable in most, but not all, cases when both equations are nonlinear.

EXAMPLE 1 Solve the following system of equations:

$$x^2 + y^2 = 25, \quad (1) \quad \text{The graph is a circle.}$$

$$3x - 4y = 0. \quad (2) \quad \text{The graph is a line.}$$

Algebraic Solution

We use the substitution method. First, we solve equation (2) for x :

$$3x - 4y = 0 \quad (2)$$

$$3x = 4y$$

$$x = \frac{4}{3}y. \quad (3) \quad \text{We could have solved for } y \text{ instead.}$$

Next, we substitute $\frac{4}{3}y$ for x in equation (1) and solve for y :

$$\left(\frac{4}{3}y\right)^2 + y^2 = 25$$

$$\frac{16}{9}y^2 + y^2 = 25$$

$$\frac{25}{9}y^2 = 25$$

$$y^2 = 9$$

Multiplying by $\frac{9}{25}$

$$y = \pm 3.$$

Now we substitute these numbers for y in equation (3) and solve for x :

$$x = \frac{4}{3}(3) = 4,$$

The pair $(4, 3)$ appears to be a solution.

$$x = \frac{4}{3}(-3) = -4.$$

The pair $(-4, -3)$ appears to be a solution.

Check: For $(4, 3)$:

$$\frac{x^2 + y^2 = 25}{4^2 + 3^2 \quad ? \quad 25}$$

$$\frac{16 + 9}{25} \quad \Bigg| \quad 25 \quad \text{TRUE}$$

$$\frac{16 + 9}{25} \quad \Bigg| \quad 25 \quad \text{TRUE}$$

$$\frac{3x - 4y = 0}{3(4) - 4(3) \quad ? \quad 0}$$

$$\frac{12 - 12}{0} \quad \Bigg| \quad 0 \quad \text{TRUE}$$

$$\frac{12 - 12}{0} \quad \Bigg| \quad 0 \quad \text{TRUE}$$

For $(-4, -3)$:

$$\frac{x^2 + y^2 = 25}{(-4)^2 + (-3)^2 \quad ? \quad 25}$$

$$\frac{16 + 9}{25} \quad \Bigg| \quad 25 \quad \text{TRUE}$$

$$\frac{16 + 9}{25} \quad \Bigg| \quad 25 \quad \text{TRUE}$$

$$\frac{3x - 4y = 0}{3(-4) - 4(-3) \quad ? \quad 0}$$

$$\frac{-12 + 12}{0} \quad \Bigg| \quad 0 \quad \text{TRUE}$$

$$\frac{-12 + 12}{0} \quad \Bigg| \quad 0 \quad \text{TRUE}$$

The pairs $(4, 3)$ and $(-4, -3)$ check, so they are the solutions.

Visualizing the Solution

The ordered pairs corresponding to the points of intersection of the graphs of the equations are the solutions of the system of equations.

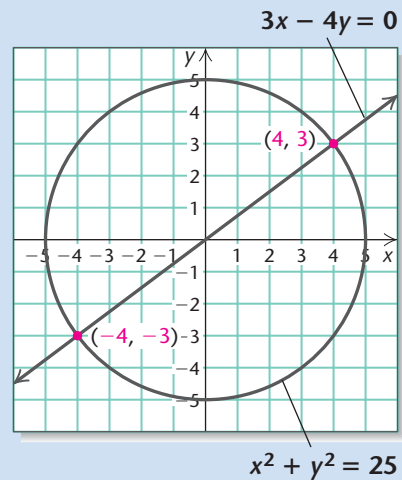

We see that the solutions are $(4, 3)$ and $(-4, -3)$.

➔ Now Try Exercise 7.

TECHNOLOGY CONNECTION

To solve the system of equations in Example 1 on a graphing calculator, we graph both equations in the same viewing window. Note that there are two points of intersection. We can find their coordinates using the INTERSECT feature.

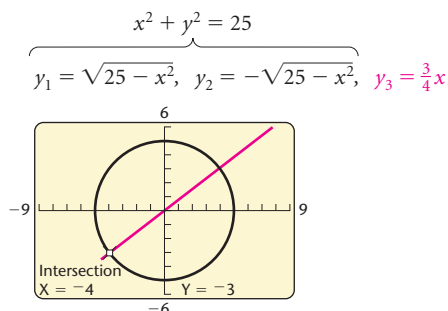
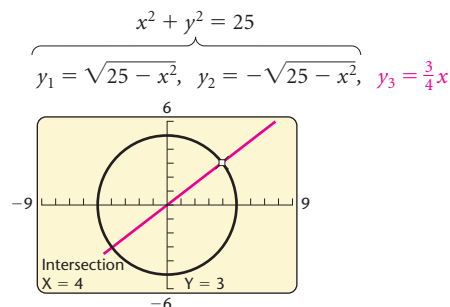

The solutions are $(4, 3)$ and $(-4, -3)$.

In the solution in Example 1, suppose that to find x we had substituted 3 and -3 in equation (1) rather than equation (3). If $y = 3$, $y^2 = 9$, and if $y = -3$, $y^2 = 9$, so both substitutions can be performed at the same time:

$$\begin{aligned} x^2 + y^2 &= 25 & (1) \\ x^2 + (\pm 3)^2 &= 25 \\ x^2 + 9 &= 25 \\ x^2 &= 16 \\ x &= \pm 4. \end{aligned}$$

Each y -value produces two values for x . Thus, if $y = 3$, $x = 4$ or $x = -4$, and if $y = -3$, $x = 4$ or $x = -4$. The possible solutions are $(4, 3)$, $(-4, 3)$, $(4, -3)$, and $(-4, -3)$. A check reveals that $(4, -3)$ and $(-4, 3)$ are not solutions of equation (2). Since a circle and a line can intersect in at most two points, it is clear that there can be at most two real-number solutions.

EXAMPLE 2 Solve the following system of equations:

$$x + y = 5, \quad (1) \quad \text{The graph is a line.}$$

$$y = 3 - x^2. \quad (2) \quad \text{The graph is a parabola.}$$

Algebraic Solution

We use the substitution method, substituting $3 - x^2$ for y in equation (1):

$$x + 3 - x^2 = 5$$

$$-x^2 + x - 2 = 0 \quad \text{Subtracting 5 and rearranging}$$

$$x^2 - x + 2 = 0. \quad \text{Multiplying by } -1$$

Next, we use the quadratic formula:

$$\begin{aligned} x &= \frac{-b \pm \sqrt{b^2 - 4ac}}{2a} = \frac{-(-1) \pm \sqrt{(-1)^2 - 4(1)(2)}}{2(1)} \\ &= \frac{1 \pm \sqrt{1 - 8}}{2} = \frac{1 \pm \sqrt{-7}}{2} = \frac{1 \pm i\sqrt{7}}{2} = \frac{1}{2} \pm \frac{\sqrt{7}}{2}i. \end{aligned}$$

Now, we substitute these values for x in equation (1) and solve for y :

$$\frac{1}{2} + \frac{\sqrt{7}}{2}i + y = 5$$

$$y = 5 - \frac{1}{2} - \frac{\sqrt{7}}{2}i = \frac{9}{2} - \frac{\sqrt{7}}{2}i$$

$$\text{and } \frac{1}{2} - \frac{\sqrt{7}}{2}i + y = 5$$

$$y = 5 - \frac{1}{2} + \frac{\sqrt{7}}{2}i = \frac{9}{2} + \frac{\sqrt{7}}{2}i.$$

The solutions are

$$\left(\frac{1}{2} + \frac{\sqrt{7}}{2}i, \frac{9}{2} - \frac{\sqrt{7}}{2}i \right) \quad \text{and} \quad \left(\frac{1}{2} - \frac{\sqrt{7}}{2}i, \frac{9}{2} + \frac{\sqrt{7}}{2}i \right).$$

There are no real-number solutions.

Visualizing the Solution

We graph the equations, as shown below.

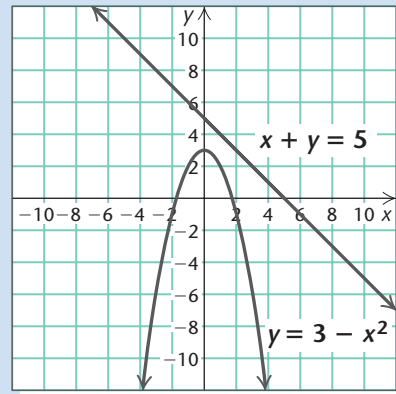

Note that there are no points of intersection. This indicates that there are no real-number solutions.

➔ Now Try Exercise 17.

EXAMPLE 3 Solve the following system of equations:

$$2x^2 + 5y^2 = 39, \quad (1) \quad \text{The graph is an ellipse.}$$

$$3x^2 - y^2 = -1. \quad (2) \quad \text{The graph is a hyperbola.}$$

Algebraic Solution

We use the elimination method. First, we multiply equation (2) by 5 and add to eliminate the y^2 -term:

$$\begin{array}{rcl} 2x^2 + 5y^2 & = & 39 \quad (1) \\ 15x^2 - 5y^2 & = & -5 \quad \text{Multiplying (2) by 5} \\ \hline 17x^2 & = & 34 \quad \text{Adding} \\ x^2 & = & 2 \\ x & = & \pm\sqrt{2}. \end{array}$$

If $x = \sqrt{2}$, $x^2 = 2$, and if $x = -\sqrt{2}$, $x^2 = 2$. Thus substituting $\sqrt{2}$ or $-\sqrt{2}$ for x in equation (2) gives us

$$\begin{array}{rcl} 3(\pm\sqrt{2})^2 - y^2 & = & -1 \\ 3 \cdot 2 - y^2 & = & -1 \\ 6 - y^2 & = & -1 \\ -y^2 & = & -7 \\ y^2 & = & 7 \\ y & = & \pm\sqrt{7}. \end{array}$$

Thus, for $x = \sqrt{2}$, we have $y = \sqrt{7}$ or $y = -\sqrt{7}$, and for $x = -\sqrt{2}$, we have $y = \sqrt{7}$ or $y = -\sqrt{7}$. The possible solutions are $(\sqrt{2}, \sqrt{7})$, $(\sqrt{2}, -\sqrt{7})$, $(-\sqrt{2}, \sqrt{7})$, $(-\sqrt{2}, -\sqrt{7})$. All four pairs check, so they are the solutions.

Visualizing the Solution

We graph the equations and note that there are four points of intersection.

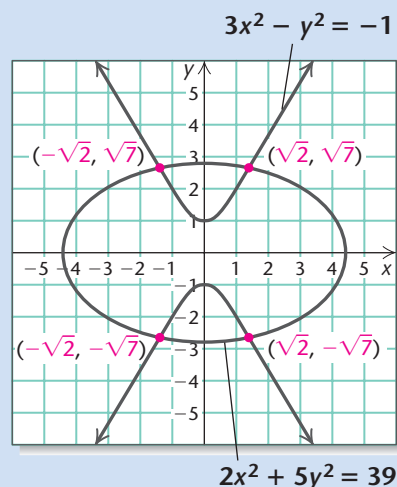

The coordinates of the points of intersection are $(\sqrt{2}, \sqrt{7})$, $(\sqrt{2}, -\sqrt{7})$, $(-\sqrt{2}, \sqrt{7})$, and $(-\sqrt{2}, -\sqrt{7})$. These are the solutions of the system of equations.

➔ Now Try Exercise 27.

TECHNOLOGY CONNECTION

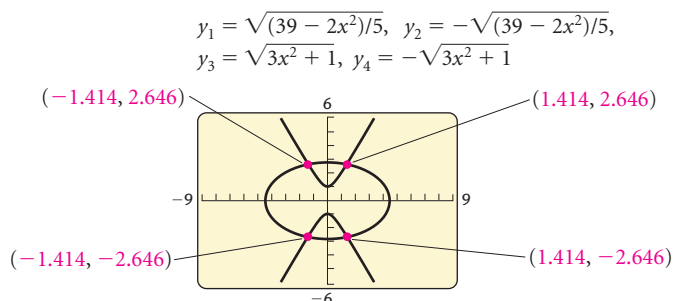

To solve the system of equations in Example 3 on a graphing calculator, we graph both equations in the same viewing window. We can use the INTERSECT feature to find the coordinates of the four points of intersection.

Note that the algebraic solution yields exact solutions, whereas the graphical solution yields decimal approximations of the solutions on most graphing calculators.

The solutions are approximately $(1.414, 2.646)$, $(1.414, -2.646)$, $(-1.414, 2.646)$, and $(-1.414, -2.646)$.

EXAMPLE 4 Solve the following system of equations:

$$x^2 - 3y^2 = 6, \quad (1)$$

$$xy = 3. \quad (2)$$

Algebraic Solution

We use the substitution method. First, we solve equation (2) for y :

$$xy = 3 \quad (2)$$

$$y = \frac{3}{x}. \quad (3) \quad \text{Dividing by } x$$

Next, we substitute $3/x$ for y in equation (1) and solve for x :

$$x^2 - 3\left(\frac{3}{x}\right)^2 = 6$$

$$x^2 - 3 \cdot \frac{9}{x^2} = 6$$

$$x^2 - \frac{27}{x^2} = 6$$

$$x^4 - 27 = 6x^2$$

$$x^4 - 6x^2 - 27 = 0$$

$$u^2 - 6u - 27 = 0$$

$$(u - 9)(u + 3) = 0$$

$$u - 9 = 0 \quad \text{or} \quad u + 3 = 0$$

$$u = 9 \quad \text{or} \quad u = -3$$

$$x^2 = 9 \quad \text{or} \quad x^2 = -3 \quad \text{Substituting } x^2 \text{ for } u$$

$$x = \pm 3 \quad \text{or} \quad x = \pm i\sqrt{3}.$$

Since $y = 3/x$,

$$\text{when } x = 3, \quad y = \frac{3}{3} = 1;$$

$$\text{when } x = -3, \quad y = \frac{3}{-3} = -1;$$

$$\text{when } x = i\sqrt{3}, \quad y = \frac{3}{i\sqrt{3}} = \frac{3}{i\sqrt{3}} \cdot \frac{-i\sqrt{3}}{-i\sqrt{3}} = -i\sqrt{3};$$

$$\text{when } x = -i\sqrt{3}, \quad y = \frac{3}{-i\sqrt{3}} = \frac{3}{-i\sqrt{3}} \cdot \frac{i\sqrt{3}}{i\sqrt{3}} = i\sqrt{3}.$$

The pairs $(3, 1)$, $(-3, -1)$, $(i\sqrt{3}, -i\sqrt{3})$, and $(-i\sqrt{3}, i\sqrt{3})$ check, so they are the solutions.

Visualizing the Solution

The coordinates of the points of intersection of the graphs of the equations give us the real-number solutions of the system of equations. These graphs do not show us the imaginary-number solutions.

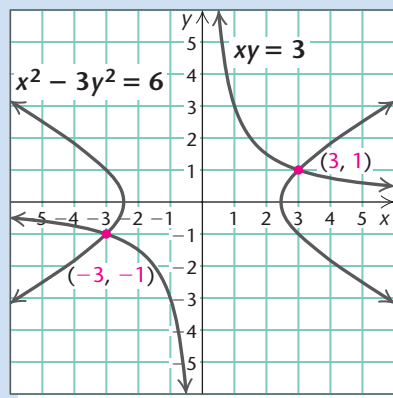

► Modeling and Problem Solving

EXAMPLE 5 *Dimensions of a Piece of Land.* For a student recreation building at Southport Community College, an architect wants to lay out a rectangular piece of land that has a perimeter of 204 m and an area of 2565 m². Find the dimensions of the piece of land.

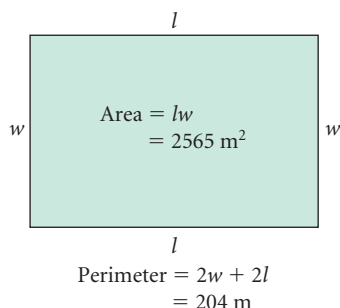

Solution

- Familiarize.** We make a drawing and label it, letting l = the length of the piece of land, in meters, and w = the width, in meters.
- Translate.** We now have the following:

$$\begin{aligned} \text{Perimeter: } 2w + 2l &= 204, & (1) \\ \text{Area: } lw &= 2565. & (2) \end{aligned}$$
- Carry out.** We solve the system of equations

$$\begin{aligned} 2w + 2l &= 204, \\ lw &= 2565. \end{aligned}$$

Solving the second equation for l gives us $l = 2565/w$. We then substitute $2565/w$ for l in equation (1) and solve for w :

$$\begin{aligned} 2w + 2\left(\frac{2565}{w}\right) &= 204 \\ 2w^2 + 2(2565) &= 204w && \text{Multiplying by } w \\ 2w^2 - 204w + 2(2565) &= 0 \\ w^2 - 102w + 2565 &= 0 && \text{Multiplying by } \frac{1}{2} \\ (w - 57)(w - 45) &= 0 \\ w - 57 = 0 \quad \text{or} \quad w - 45 = 0 &&& \text{Principle of zero products} \\ w = 57 \quad \text{or} \quad w = 45. &&& \end{aligned}$$

If $w = 57$, then $l = 2565/w = 2565/57 = 45$. If $w = 45$, then $l = 2565/w = 2565/45 = 57$. Since length is generally considered to be longer than width, we have the solution $l = 57$ and $w = 45$, or $(57, 45)$.

- Check.** If $l = 57$ and $w = 45$, the perimeter is $2 \cdot 45 + 2 \cdot 57$, or 204. The area is $57 \cdot 45$, or 2565. The numbers check.
- State.** The length of the piece of land is 57 m and the width is 45 m.

➔ Now Try Exercise 61.

STUDY TIP

Prepare for each chapter test by rereading the text, reviewing your homework, reading the important properties and formulas in the end-of-chapter Study Guide, and doing the review exercises. Then take the chapter test at the end of the chapter.

SYSTEMS OF INEQUALITIES

REVIEW SECTION 9.7

► Nonlinear Systems of Inequalities

Recall that a solution of a system of inequalities is an ordered pair that is a solution of each inequality in the system. We graphed systems of linear inequalities in Section 9.7. Now we graph a nonlinear system of inequalities.

EXAMPLE 6 Graph the solution set of the system

$$\begin{aligned} x^2 + y^2 &\leq 25, \\ 3x - 4y &> 0. \end{aligned}$$

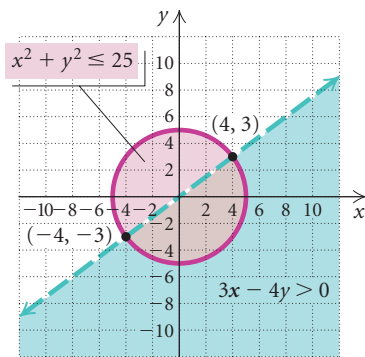

Solution We graph $x^2 + y^2 \leq 25$ by first graphing the related equation of the circle $x^2 + y^2 = 25$. We use a solid line since the inequality symbol is \leq . Next, we choose $(0, 0)$ as a test point and find that it is a solution of $x^2 + y^2 \leq 25$, so we shade the region that contains $(0, 0)$ using red. This is the region inside the circle. Now we graph the line $3x - 4y = 0$ using a dashed line since the inequality symbol is $>$. The point $(0, 0)$ is on the line, so we choose another test point, say, $(0, 2)$. We find that this point is not a solution of $3x - 4y > 0$, so we shade the half-plane that does not contain $(0, 2)$ using green. The solution set of the system of inequalities is the region shaded both red and green, or brown, including part of the circle $x^2 + y^2 = 25$.

To find the points of intersection of the graphs of the related equations, we solve the system composed of those equations:

$$x^2 + y^2 = 25,$$

$$3x - 4y = 0.$$

In Example 1, we found that these points are $(4, 3)$ and $(-4, -3)$.

➔ Now Try Exercise 75.

TECHNOLOGY CONNECTION

To use a graphing calculator to graph the system of inequalities in Example 7, we first graph $y_1 = 4 - x^2$ and $y_2 = 2 - x$. Using the test point $(0, 0)$ for each inequality, we find that we should shade below y_1 and above y_2 . We can find the points of intersection of the graphs of the related equations, $(-1, 3)$ and $(2, 0)$, using the INTERSECT feature.

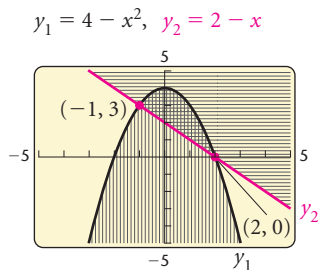

EXAMPLE 7 Graph the solution set of the system

$$y \leq 4 - x^2,$$

$$x + y \geq 2.$$

Solution We graph $y \leq 4 - x^2$ by first graphing the equation of the parabola $y = 4 - x^2$. We use a solid line since the inequality symbol is \leq . Next, we choose $(0, 0)$ as a test point and find that it is a solution of $y \leq 4 - x^2$, so we shade the region that contains $(0, 0)$ using red. Now we graph the line $x + y = 2$, again using a solid line since the inequality symbol is \geq . We test the point $(0, 0)$ and find that it is not a solution of $x + y \geq 2$, so we shade the half-plane that does not contain $(0, 0)$ using green. The solution set of the system of inequalities is the region shaded both red and green, or brown, including part of the parabola $y = 4 - x^2$ and part of the line $x + y = 2$.

Solving the system of equations

$$y = 4 - x^2,$$

$$x + y = 2,$$

we find that the points of intersection of the graphs of the related equations are $(-1, 3)$ and $(2, 0)$.

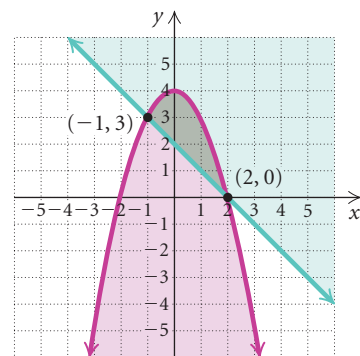

➔ Now Try Exercise 81.

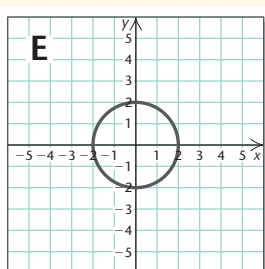
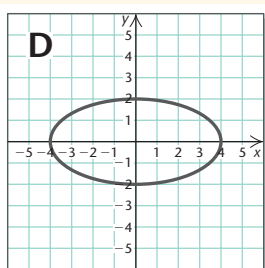
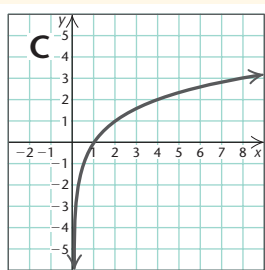
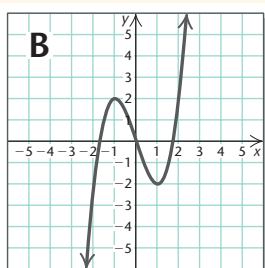
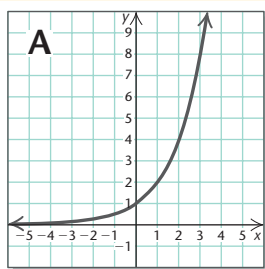

Visualizing the Graph

Match the equation or system of equations with its graph.

- $y = x^3 - 3x$
- $y = x^2 + 2x - 3$
- $y = \frac{x - 1}{x^2 - x - 2}$
- $y = -3x + 2$
- $x + y = 3,$
 $2x + 5y = 3$
- $9x^2 - 4y^2 = 36,$
 $x^2 + y^2 = 9$
- $5x^2 + 5y^2 = 20$
- $4x^2 + 16y^2 = 64$
- $y = \log_2 x$
- $y = 2^x$

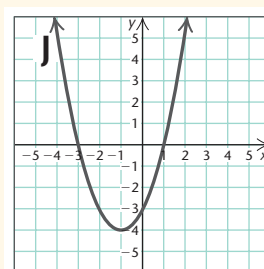
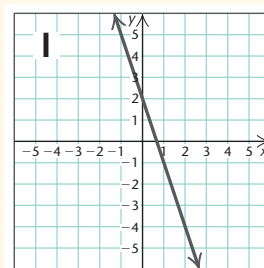
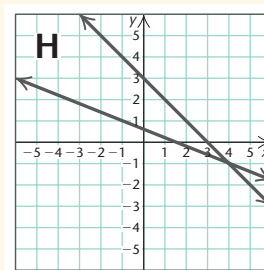
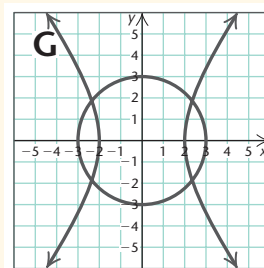
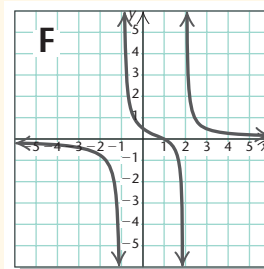

Answers on page A-66

10.4 Exercise Set

In Exercises 1–6, match the system of equations with one of the graphs (a)–(f), which follow.

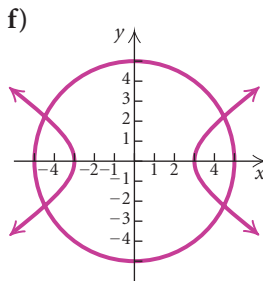
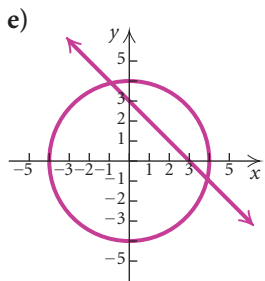
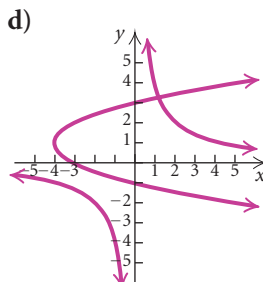
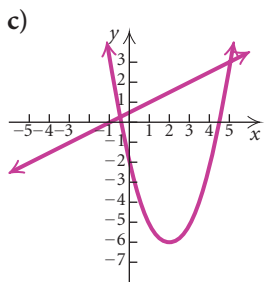
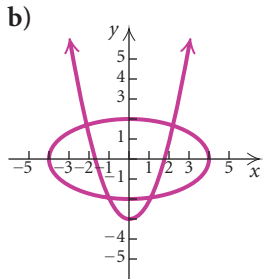
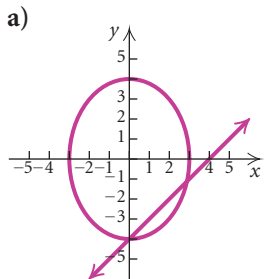

- $x^2 + y^2 = 16,$
 $x + y = 3$
- $y = x^2 - 4x - 2,$
 $2y - x = 1$
- $y = x^2 - 3,$
 $x^2 + 4y^2 = 16$

- $16x^2 + 9y^2 = 144,$
 $x - y = 4$
- $4x^2 - 9y^2 = 36,$
 $x^2 + y^2 = 25$
- $y^2 - 2y = x + 3,$
 $xy = 4$

Solve.

- $x^2 + y^2 = 25,$
 $y - x = 1$
- $4x^2 + 9y^2 = 36,$
 $3y + 2x = 6$
- $x^2 + y^2 = 25,$
 $y^2 = x + 5$

- $x^2 + y^2 = 100,$
 $y - x = 2$
- $9x^2 + 4y^2 = 36,$
 $3x + 2y = 6$
- $y = x^2,$
 $x = y^2$

13. $x^2 + y^2 = 9$
 $x^2 - y^2 = 9$

15. $y^2 - x^2 = 9,$
 $2x - 3 = y$

17. $y^2 = x + 3,$
 $2y = x + 4$

19. $x^2 + y^2 = 25,$
 $xy = 12$

21. $x^2 + y^2 = 4,$
 $16x^2 + 9y^2 = 144$

23. $x^2 + 4y^2 = 25,$
 $x + 2y = 7$

25. $x^2 - xy + 3y^2 = 27,$
 $x - y = 2$

27. $x^2 + y^2 = 16,$
 $y^2 - 2x^2 = 10$

29. $x^2 + y^2 = 5,$
 $xy = 2$

31. $3x + y = 7,$
 $4x^2 + 5y = 56$

33. $a + b = 7,$
 $ab = 4$

35. $x^2 + y^2 = 13,$
 $xy = 6$

37. $x^2 + y^2 + 6y + 5 = 0,$
 $x^2 + y^2 - 2x - 8 = 0$

38. $2xy + 3y^2 = 7,$
 $3xy - 2y^2 = 4$

40. $4x^2 + 9y^2 = 36,$
 $x + 3y = 3$

42. $xy = 4,$
 $x + y = 5$

44. $4a^2 - 25b^2 = 0,$
 $2a^2 - 10b^2 = 3b + 4$

45. $m^2 - 3mn + n^2 + 1 = 0,$
 $3m^2 - mn + 3n^2 = 13$

14. $y^2 - 4x^2 = 4,$
 $4x^2 + y^2 = 4$

16. $x + y = -6,$
 $xy = -7$

18. $y = x^2,$
 $3x = y + 2$

20. $x^2 - y^2 = 16,$
 $x + y^2 = 4$

22. $x^2 + y^2 = 25,$
 $25x^2 + 16y^2 = 400$

24. $y^2 - x^2 = 16,$
 $2x - y = 1$

26. $2y^2 + xy + x^2 = 7,$
 $x - 2y = 5$

28. $x^2 + y^2 = 14,$
 $x^2 - y^2 = 4$

30. $x^2 + y^2 = 20,$
 $xy = 8$

32. $2y^2 + xy = 5,$
 $4y + x = 7$

34. $p + q = -4,$
 $pq = -5$

36. $x^2 + 4y^2 = 20,$
 $xy = 4$

39. $2a + b = 1,$
 $b = 4 - a^2$

41. $a^2 + b^2 = 89,$
 $a - b = 3$

43. $xy - y^2 = 2,$
 $2xy - 3y^2 = 0$

46. $ab - b^2 = -4$,
 $ab - 2b^2 = -6$
47. $x^2 + y^2 = 5$,
 $x - y = 8$
48. $4x^2 + 9y^2 = 36$,
 $y - x = 8$
49. $a^2 + b^2 = 14$,
 $ab = 3\sqrt{5}$
50. $x^2 + xy = 5$,
 $2x^2 + xy = 2$
51. $x^2 + y^2 = 25$,
 $9x^2 + 4y^2 = 36$
52. $x^2 + y^2 = 1$,
 $9x^2 - 16y^2 = 144$
53. $5y^2 - x^2 = 1$,
 $xy = 2$
54. $x^2 - 7y^2 = 6$,
 $xy = 1$

In Exercises 55–58, determine whether the statement is true or false.

55. A nonlinear system of equations can have both real-number solutions and imaginary-number solutions.
56. If the graph of a nonlinear system of equations consists of a line and a parabola, the system has two real-number solutions.
57. If the graph of a nonlinear system of equations consists of a line and a circle, the system has at most two real-number solutions.
58. If the graph of a nonlinear system of equations consists of a line and an ellipse, it is possible for the system to have exactly one real-number solution.
59. **Picture Frame Dimensions.** Frank's Frame Shop is building a frame for a rectangular oil painting with a perimeter of 28 cm and a diagonal of 10 cm. Find the dimensions of the painting.



60. **Sign Dimensions.** Peden's Advertising is building a rectangular sign with an area of 2 yd^2 and a perimeter of 6 yd. Find the dimensions of the sign.

61. **Graphic Design.** Marcia Graham, owner of Graham's Graphics, is designing an advertising brochure for the Art League's spring show. Each page of the brochure is rectangular with an area of 20 in^2 and a perimeter of 18 in. Find the dimensions of the brochure.
62. **Landscaping.** Green Leaf Landscaping is planting a rectangular wildflower garden with a perimeter of 6 m and a diagonal of $\sqrt{5}$ m. Find the dimensions of the garden.



63. **Fencing.** It will take 210 yd of fencing to enclose a rectangular dog pen. The area of the pen is 2250 yd^2 . What are the dimensions of the pen?
64. **Carpentry.** Ted Hansen of Hansen Woodworking Designs has been commissioned to make a rectangular tabletop with an area of $\sqrt{2} \text{ m}^2$ and a diagonal of $\sqrt{3}$ m for the Decorators' Show House. Find the dimensions of the tabletop.
65. **Banner Design.** A rectangular banner with an area of $\sqrt{3} \text{ m}^2$ is being designed to advertise an exhibit at the Davis Gallery. The length of a diagonal is 2 m. Find the dimensions of the banner.



66. **Investment.** Jenna made an investment for 1 year that earned \$7.50 simple interest. If the principal

had been \$25 more and the interest rate 1% less, the interest would have been the same. Find the principal and the interest rate.

67. **Seed Test Plots.** The Burton Seed Company has two square test plots. The sum of their areas is 832 ft^2 and the difference of their areas is 320 ft^2 . Find the length of a side of each plot.



68. **Office Dimensions.** The diagonal of the floor of a rectangular office cubicle is 1 ft longer than the length of the cubicle and 3 ft longer than twice the width. Find the dimensions of the cubicle.



In Exercises 69–74, match the system of inequalities with one of the graphs (a)–(f), which follow.

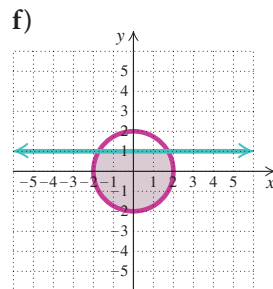
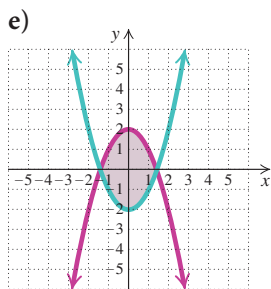
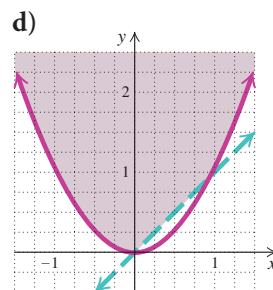
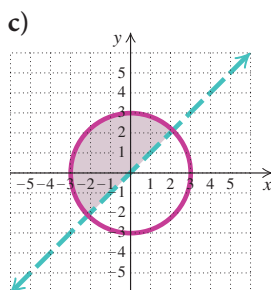
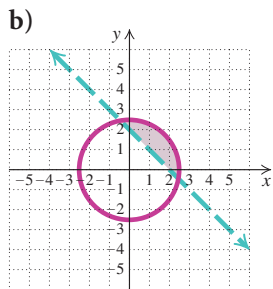
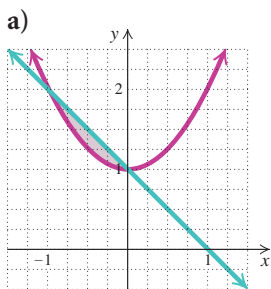

69. $x^2 + y^2 \leq 5,$
 $x + y > 2$

71. $y \geq x^2,$
 $y > x$

73. $y \geq x^2 + 1,$
 $x + y \leq 1$

70. $y \leq 2 - x^2,$
 $y \geq x^2 - 2$

72. $x^2 + y^2 \leq 4,$
 $y \leq 1$

74. $x^2 + y^2 \leq 9,$
 $y > x$

Graph the system of inequalities. Then find the coordinates of the points of intersection of the graphs of the related equations.

75. $x^2 + y^2 \leq 16,$
 $y < x$

77. $x^2 \leq y,$
 $x + y \geq 2$

79. $x^2 + y^2 \leq 25,$
 $x - y > 5$

81. $y \geq x^2 - 3,$
 $y \leq 2x$

83. $y \geq x^2,$
 $y < x + 2$

76. $x^2 + y^2 \leq 10,$
 $y > x$

78. $x \geq y^2,$
 $x - y \leq 2$

80. $x^2 + y^2 \geq 9,$
 $x - y > 3$

82. $y \leq 3 - x^2,$
 $y \geq x + 1$

84. $y \leq 1 - x^2,$
 $y > x - 1$

Skill Maintenance

Solve.

85. $2^{3x} = 64$
86. $5^x = 27$
87. $\log_3 x = 4$
88. $\log(x - 3) + \log x = 1$

Synthesis

89. Find an equation of the circle that passes through the points (2, 4) and (3, 3) and whose center is on the line $3x - y = 3$.
90. Find an equation of the circle that passes through the points (-2, 3) and (-4, 1) and whose center is on the line $5x + 8y = -2$.
91. Find an equation of an ellipse centered at the origin that passes through the points $(1, \sqrt{3}/2)$ and $(\sqrt{3}, 1/2)$.

92. Find an equation of a hyperbola of the type

$$\frac{x^2}{b^2} - \frac{y^2}{a^2} = 1$$

that passes through the points $(-3, -3\sqrt{5}/2)$ and $(-3/2, 0)$.

93. Find an equation of the circle that passes through the points (4, 6), (6, 2), and (1, -3).
94. Find an equation of the circle that passes through the points (2, 3), (4, 5), and (0, -3).
95. Show that a hyperbola does not intersect its asymptotes. That is, solve the system of equations

$$\frac{x^2}{a^2} - \frac{y^2}{b^2} = 1,$$

$$y = \frac{b}{a}x \quad \left(\text{or } y = -\frac{b}{a}x \right).$$

96. *Numerical Relationship.* Find two numbers whose product is 2 and the sum of whose reciprocals is $\frac{33}{8}$.

97. *Numerical Relationship.* The square of a number exceeds twice the square of another number by $\frac{1}{8}$. The sum of their squares is $\frac{5}{16}$. Find the numbers.
98. *Box Dimensions.* Four squares with sides 5 in. long are cut from the corners of a rectangular metal sheet that has an area of 340 in^2 . The edges are bent up to form an open box with a volume of 350 in^3 . Find the dimensions of the box.
99. *Numerical Relationship.* The sum of two numbers is 1, and their product is 1. Find the sum of their cubes. There is a method to solve this problem that is easier than solving a nonlinear system of equations. Can you discover it?

100. Solve for x and y :

$$x^2 - y^2 = a^2 - b^2,$$

$$x - y = a - b.$$

Solve.

101. $x^3 + y^3 = 72,$
 $x + y = 6$

102. $a + b = \frac{5}{6},$

$$\frac{a}{b} + \frac{b}{a} = \frac{13}{6}$$

103. $p^2 + q^2 = 13,$
 $\frac{1}{pq} = -\frac{1}{6}$

104. $x^2 + y^2 = 4,$
 $(x - 1)^2 + y^2 = 4$

105. $5^{x+y} = 100,$
 $3^{2x-y} = 1000$

106. $e^x - e^{x+y} = 0,$
 $e^y - e^{x-y} = 0$

Mid-Chapter Mixed Review

Determine whether the statement is true or false.

- The graph of $(x + 3)^2 = 8(y - 2)$ is a parabola with vertex $(-3, 2)$. [10.1]
- The graph of $(x - 4)^2 + (y + 1)^2 = 9$ is a circle with radius 9. [10.2]
- The hyperbola $\frac{x^2}{5} - \frac{y^2}{10} = 1$ has a horizontal transverse axis. [10.3]
- Every nonlinear system of equations has at least one real-number solution. [10.4]

In Exercises 5–12, match the equation with one of the graphs (a)–(h), which follow. [10.1], [10.2], [10.3]

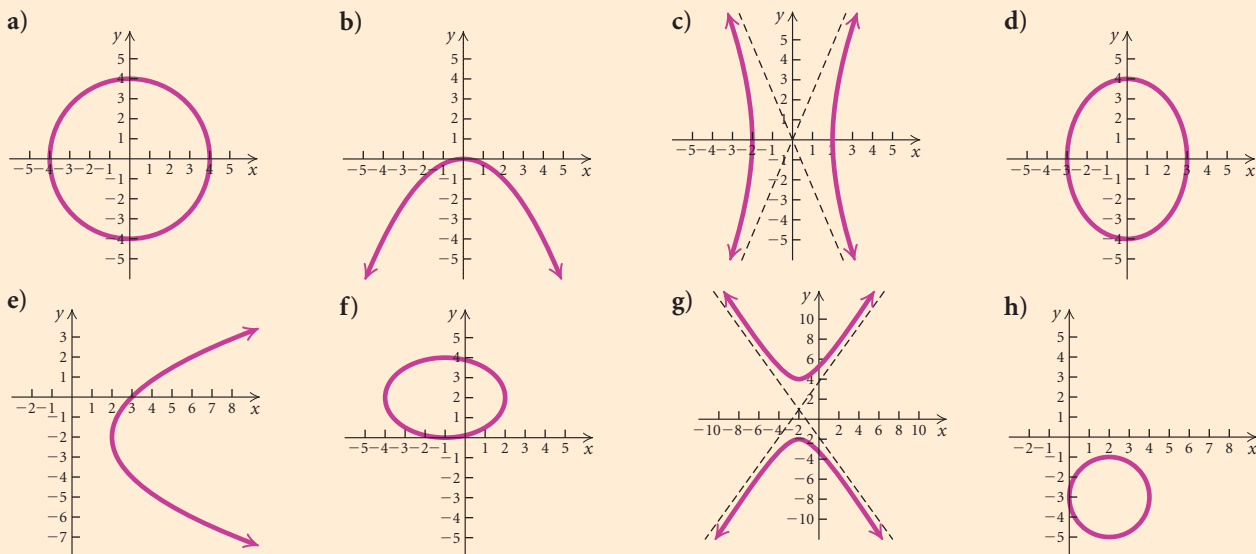

- $x^2 = -4y$
- $16x^2 + 9y^2 = 144$
- $4(y - 1)^2 - 9(x + 2)^2 = 36$
- $(x - 2)^2 + (y + 3)^2 = 4$
- $(y + 2)^2 = 4(x - 2)$
- $x^2 + y^2 = 16$
- $4(x + 1)^2 + 9(y - 2)^2 = 36$
- $25x^2 - 4y^2 = 100$

Find the vertex, the focus, and the directrix of the parabola. Then draw the graph. [10.1]

- $y^2 = 12x$
- $x^2 - 6x - 4y = -17$

Find the center and the radius of the circle. Then draw the graph. [10.2]

- $x^2 + y^2 + 4x - 8y = 5$
- $x^2 + y^2 - 6x + 2y - 6 = 0$

Find the vertices and the foci of the ellipse. Then draw the graph. [10.2]

- $\frac{x^2}{1} + \frac{y^2}{9} = 1$
- $25x^2 + 4y^2 - 50x + 8y = 71$

Find the center, the vertices, the foci, and the asymptotes of the hyperbola. Then draw the graph. [10.3]

- $9y^2 - 16x^2 = 144$
- $\frac{(x + 3)^2}{1} - \frac{(y - 2)^2}{4} = 1$

Solve. [10.4]

$$21. \begin{cases} x^2 + y^2 = 29, \\ x - y = 3 \end{cases}$$

$$23. \begin{cases} x^2 + 2y^2 = 20, \\ y^2 - x^2 = 28 \end{cases}$$

25. The sum of two numbers is 1 and the sum of their squares is 13. Find the numbers. [10.4]

Graph the system of inequalities. Then find the coordinates of the points of intersection of the graphs of the related equations. [10.4]

$$26. \begin{cases} x^2 + y^2 \leq 8, \\ x > y \end{cases}$$

$$22. \begin{cases} x^2 + y^2 = 8, \\ xy = 4 \end{cases}$$

$$24. \begin{cases} 2x - y = -4, \\ 3x^2 + 2y = 7 \end{cases}$$

$$27. \begin{cases} y \geq x^2 - 1, \\ y \leq x + 1 \end{cases}$$

Collaborative Discussion and Writing

28. Is a parabola always the graph of a function? Why or why not? [10.1]
29. Is the center of an ellipse part of the graph of the ellipse? Why or why not? [10.2]
30. Are the asymptotes of a hyperbola part of the graph of the hyperbola? Why or why not? [10.3]
31. What would you say to a classmate who tells you that it is always possible to visualize all the solutions of a nonlinear system of equations? [10.4]

Rotation of Axes

10.5

- ▶ Use rotation of axes to graph conic sections.
- ▶ Use the discriminant to determine the type of conic represented by a given equation.

CONIC SECTIONS

REVIEW SECTIONS 10.1–10.3

In Section 10.1, we saw that conic sections can be defined algebraically using a second-degree equation of the form $Ax^2 + Bxy + Cy^2 + Dx + Ey + F = 0$. Up to this point, we have considered only equations of this form for which $B = 0$. Now we turn our attention to equations of conics that contain an xy -term.

▶ Rotation of Axes

When B is nonzero, the graph of $Ax^2 + Bxy + Cy^2 + Dx + Ey + F = 0$ is a conic section with an axis that is parallel to neither the x -axis nor the y -axis. We use a technique called **rotation of axes** when we graph such an

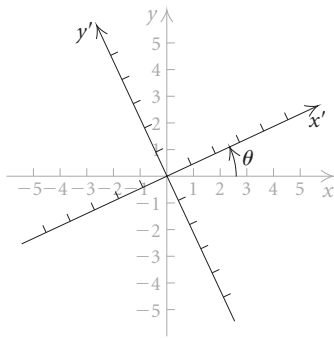

equation. The goal is to rotate the x - and y -axes through a positive angle θ to yield an $x'y'$ -coordinate system, as shown at left. For the appropriate choice of θ , the graph of any conic section with an xy -term will have its axis parallel to the x' -axis or the y' -axis.

Algebraically we want to rewrite an equation

$$Ax^2 + Bxy + Cy^2 + Dx + Ey + F = 0$$

in the xy -coordinate system in the form

$$A'(x')^2 + C'(y')^2 + D'x' + E'y' + F' = 0$$

in the $x'y'$ -coordinate system. Equations of this second type were graphed in Sections 10.1–10.3.

To achieve our goal, we find formulas relating the xy -coordinates of a point and the $x'y'$ -coordinates of the same point. We begin by letting P be a point with coordinates (x, y) in the xy -coordinate system and (x', y') in the $x'y'$ -coordinate system.

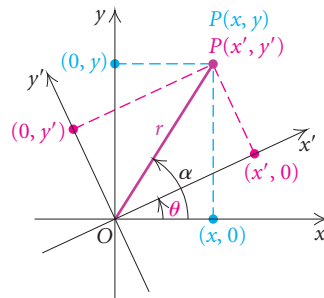

We let r represent the distance OP , and we let α represent the angle from the x -axis to OP . Then

$$\cos \alpha = \frac{x}{r} \quad \text{and} \quad \sin \alpha = \frac{y}{r},$$

so

$$x = r \cos \alpha \quad \text{and} \quad y = r \sin \alpha.$$

We also see from the figure above that

$$\cos(\alpha - \theta) = \frac{x'}{r} \quad \text{and} \quad \sin(\alpha - \theta) = \frac{y'}{r},$$

so

$$x' = r \cos(\alpha - \theta) \quad \text{and} \quad y' = r \sin(\alpha - \theta).$$

Then

$$x' = r \cos \alpha \cos \theta + r \sin \alpha \sin \theta$$

and

$$y' = r \sin \alpha \cos \theta - r \cos \alpha \sin \theta.$$

Substituting x for $r \cos \alpha$ and y for $r \sin \alpha$ gives us

$$x' = x \cos \theta + y \sin \theta \quad (1)$$

and

$$y' = y \cos \theta - x \sin \theta. \quad (2)$$

We can use these formulas to find the $x'y'$ -coordinates of any point given that point's xy -coordinates and an angle of rotation θ . To express xy -coordinates in terms of $x'y'$ -coordinates and an angle of rotation θ , we solve the system composed of equations (1) and (2) above for x and y . (See Exercise 43.) We get

$$x = x' \cos \theta - y' \sin \theta$$

and

$$y = x' \sin \theta + y' \cos \theta.$$

Rotation of Axes Formulas

If the x - and y -axes are rotated about the origin through a positive acute angle θ , then the coordinates (x, y) and (x', y') of a point P in the xy - and $x'y'$ -coordinate systems are related by the following formulas:

$$\begin{aligned} x' &= x \cos \theta + y \sin \theta, & y' &= -x \sin \theta + y \cos \theta; \\ x &= x' \cos \theta - y' \sin \theta, & y &= x' \sin \theta + y' \cos \theta. \end{aligned}$$

STUDY TIP

If you are finding it difficult to master a particular topic or concept, talk about it with a classmate. Verbalizing your questions about the material might help clarify it for you.

EXAMPLE 1 Suppose that the xy -axes are rotated through an angle of 45° . Write the equation $xy = 1$ in the $x'y'$ -coordinate system.

Solution We substitute 45° for θ in the rotation of axes formulas for x and y :

$$\begin{aligned} x &= x' \cos 45^\circ - y' \sin 45^\circ, \\ y &= x' \sin 45^\circ + y' \cos 45^\circ. \end{aligned}$$

We know that

$$\sin 45^\circ = \frac{\sqrt{2}}{2} \quad \text{and} \quad \cos 45^\circ = \frac{\sqrt{2}}{2},$$

so we have

$$x = x' \left(\frac{\sqrt{2}}{2} \right) - y' \left(\frac{\sqrt{2}}{2} \right) = \frac{\sqrt{2}}{2} (x' - y')$$

and

$$y = x' \left(\frac{\sqrt{2}}{2} \right) + y' \left(\frac{\sqrt{2}}{2} \right) = \frac{\sqrt{2}}{2} (x' + y').$$

Next, we substitute these expressions for x and y in the equation $xy = 1$:

$$\frac{\sqrt{2}}{2} (x' - y') \cdot \frac{\sqrt{2}}{2} (x' + y') = 1$$

$$\frac{1}{2} [(x')^2 - (y')^2] = 1$$

$$\frac{(x')^2}{2} - \frac{(y')^2}{2} = 1, \quad \text{or} \quad \frac{(x')^2}{(\sqrt{2})^2} - \frac{(y')^2}{(\sqrt{2})^2} = 1.$$

We have the equation of a hyperbola in the $x'y'$ -coordinate system with its transverse axis on the x' -axis and with vertices $(-\sqrt{2}, 0)$ and $(\sqrt{2}, 0)$. Its asymptotes are $y' = -x'$ and $y' = x'$. These correspond to the axes of the xy -coordinate system.

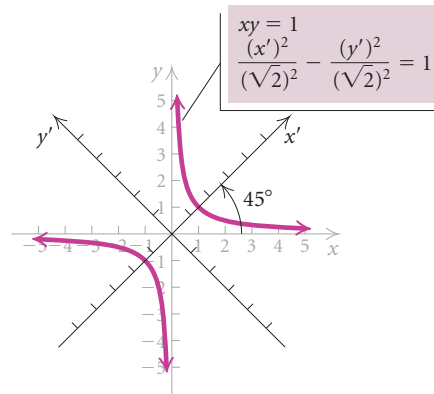

Now let's substitute the rotation of axes formulas for x and y in the equation

$$Ax^2 + Bxy + Cy^2 + Dx + Ey + F = 0.$$

We have

$$\begin{aligned} A(x' \cos \theta - y' \sin \theta)^2 + B(x' \cos \theta - y' \sin \theta)(x' \sin \theta + y' \cos \theta) \\ + C(x' \sin \theta + y' \cos \theta)^2 + D(x' \cos \theta - y' \sin \theta) \\ + E(x' \sin \theta + y' \cos \theta) + F = 0. \end{aligned}$$

Performing the operations indicated and collecting like terms yields the equation

$$A'(x')^2 + B'x'y' + C'(y')^2 + D'x' + E'y' + F' = 0, \quad (3)$$

where

$$\begin{aligned} A' &= A \cos^2 \theta + B \sin \theta \cos \theta + C \sin^2 \theta, \\ B' &= 2(C - A) \sin \theta \cos \theta + B(\cos^2 \theta - \sin^2 \theta), \\ C' &= A \sin^2 \theta - B \sin \theta \cos \theta + C \cos^2 \theta, \\ D' &= D \cos \theta + E \sin \theta, \\ E' &= -D \sin \theta + E \cos \theta, \quad \text{and} \\ F' &= F. \end{aligned}$$

Recall that our goal is to produce an equation without an $x'y'$ -term, or with $B' = 0$. Then we must have

$$2(C - A) \sin \theta \cos \theta + B(\cos^2 \theta - \sin^2 \theta) = 0$$

$$(C - A) \sin 2\theta + B \cos 2\theta = 0 \quad \text{Using double-angle formulas}$$

$$B \cos 2\theta = (A - C) \sin 2\theta$$

$$\frac{\cos 2\theta}{\sin 2\theta} = \frac{A - C}{B}$$

$$\cot 2\theta = \frac{A - C}{B}.$$

Thus, when θ is chosen so that

$$\cot 2\theta = \frac{A - C}{B},$$

equation (3) will have no $x'y'$ -term. Although we will not do so here, it can be shown that we can always find θ such that $0^\circ < 2\theta < 180^\circ$, or $0^\circ < \theta < 90^\circ$.

Eliminating the xy -Term

To eliminate the xy -term from the equation

$$Ax^2 + Bxy + Cy^2 + Dx + Ey + F = 0, \quad B \neq 0,$$

select an angle θ such that

$$\cot 2\theta = \frac{A - C}{B}, \quad 0^\circ < 2\theta < 180^\circ,$$

and use the rotation of axes formulas.

EXAMPLE 2 Graph the equation

$$3x^2 - 2\sqrt{3}xy + y^2 + 2x + 2\sqrt{3}y = 0.$$

Solution We have

$$A = 3, \quad B = -2\sqrt{3}, \quad C = 1, \quad D = 2, \quad E = 2\sqrt{3}, \quad \text{and} \quad F = 0.$$

To select the angle of rotation θ , we must have

$$\cot 2\theta = \frac{A - C}{B} = \frac{3 - 1}{-2\sqrt{3}} = \frac{2}{-2\sqrt{3}} = -\frac{1}{\sqrt{3}}.$$

Thus, $2\theta = 120^\circ$, and $\theta = 60^\circ$. We substitute this value for θ in the rotation of axes formulas for x and y :

$$x = x' \cos 60^\circ - y' \sin 60^\circ,$$

$$y = x' \sin 60^\circ + y' \cos 60^\circ.$$

This gives us

$$x = x' \cdot \frac{1}{2} - y' \cdot \frac{\sqrt{3}}{2} = \frac{x'}{2} - \frac{y'\sqrt{3}}{2}$$

and

$$y = x' \cdot \frac{\sqrt{3}}{2} + y' \cdot \frac{1}{2} = \frac{x'\sqrt{3}}{2} + \frac{y'}{2}.$$

Now we substitute these expressions for x and y in the given equation:

$$\begin{aligned} 3\left(\frac{x'}{2} - \frac{y'\sqrt{3}}{2}\right)^2 - 2\sqrt{3}\left(\frac{x'}{2} - \frac{y'\sqrt{3}}{2}\right)\left(\frac{x'\sqrt{3}}{2} + \frac{y'}{2}\right) + \\ \left(\frac{x'\sqrt{3}}{2} + \frac{y'}{2}\right)^2 + 2\left(\frac{x'}{2} - \frac{y'\sqrt{3}}{2}\right) + 2\sqrt{3}\left(\frac{x'\sqrt{3}}{2} + \frac{y'}{2}\right) = 0. \end{aligned}$$

After simplifying, we get

$$4(y')^2 + 4x' = 0, \quad \text{or}$$

$$(y')^2 = -x'.$$

This is the equation of a parabola with its vertex at $(0, 0)$ of the $x'y'$ -coordinate system and axis of symmetry $y' = 0$. We draw the graph.

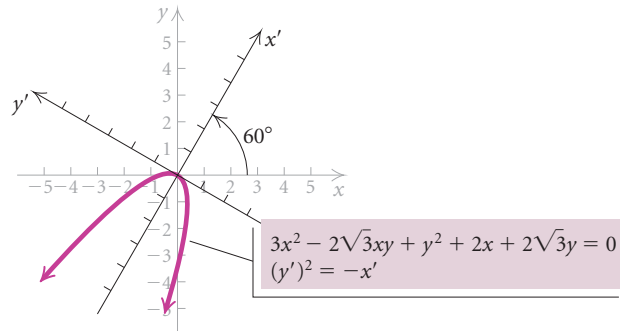

➔ Now Try Exercise 23.

► The Discriminant

It is possible to determine the type of conic represented by the equation $Ax^2 + Bxy + Cy^2 + Dx + Ey + F = 0$ before rotating the axes. Using the expressions for A' , B' , and C' in terms of A , B , C , and θ developed earlier, it can be shown that

$$(B')^2 - 4A'C' = B^2 - 4AC.$$

Now when θ is chosen so that

$$\cot 2\theta = \frac{A - C}{B},$$

rotation of axes gives us an equation

$$A'(x')^2 + C'(y')^2 + D'x' + E'y' + F' = 0.$$

If A' and C' have the same sign, or $A'C' > 0$, then the graph of this equation is an ellipse or a circle. If A' and C' have different signs, or $A'C' < 0$, then the graph is a hyperbola. And, if either $A' = 0$ or $C' = 0$, or $A'C' = 0$, the graph is a parabola.

Since $B' = 0$ and $(B')^2 - 4A'C' = B^2 - 4AC$, it follows that $B^2 - 4AC = -4A'C'$. Then the graph is an ellipse or a circle if $B^2 - 4AC < 0$, a hyperbola if $B^2 - 4AC > 0$, or a parabola if $B^2 - 4AC = 0$. (There are certain special cases, called *degenerate conics*, where these statements do not hold, but we will not concern ourselves with these here.) The expression $B^2 - 4AC$ is the **discriminant** of the equation $Ax^2 + Bxy + Cy^2 + Dx + Ey + F = 0$.

The graph of the equation

$$Ax^2 + Bxy + Cy^2 + Dx + Ey + F = 0$$

is, except in degenerate cases,

1. an ellipse or a circle if $B^2 - 4AC < 0$,
2. a hyperbola if $B^2 - 4AC > 0$, and
3. a parabola if $B^2 - 4AC = 0$.

EXAMPLE 3 Graph the equation $3x^2 + 2xy + 3y^2 = 16$.

Solution We have

$$A = 3, \quad B = 2, \quad \text{and} \quad C = 3, \quad \text{so}$$

$$B^2 - 4AC = 2^2 - 4 \cdot 3 \cdot 3 = 4 - 36 = -32.$$

Since the discriminant is negative, the graph is an ellipse or a circle. Now, to rotate the axes, we begin by determining θ :

$$\cot 2\theta = \frac{A - C}{B} = \frac{3 - 3}{2} = \frac{0}{2} = 0.$$

Then $2\theta = 90^\circ$ and $\theta = 45^\circ$, so

$$\sin \theta = \frac{\sqrt{2}}{2} \quad \text{and} \quad \cos \theta = \frac{\sqrt{2}}{2}.$$

As we saw in Example 1, substituting these values for $\sin \theta$ and $\cos \theta$ in the rotation of axes formulas gives

$$x = \frac{\sqrt{2}}{2}(x' - y') \quad \text{and} \quad y = \frac{\sqrt{2}}{2}(x' + y').$$

Now we substitute for x and y in the given equation:

$$3 \left[\frac{\sqrt{2}}{2}(x' - y') \right]^2 + 2 \left[\frac{\sqrt{2}}{2}(x' - y') \right] \left[\frac{\sqrt{2}}{2}(x' + y') \right] + 3 \left[\frac{\sqrt{2}}{2}(x' + y') \right]^2 = 16.$$

After simplifying, we have

$$4(x')^2 + 2(y')^2 = 16, \quad \text{or}$$

$$\frac{(x')^2}{4} + \frac{(y')^2}{8} = 1.$$

This is the equation of an ellipse with vertices $(0, -\sqrt{8})$ and $(0, \sqrt{8})$, or $(0, -2\sqrt{2})$ and $(0, 2\sqrt{2})$, on the y' -axis. The x' -intercepts are $(-2, 0)$ and $(2, 0)$. We draw the graph.

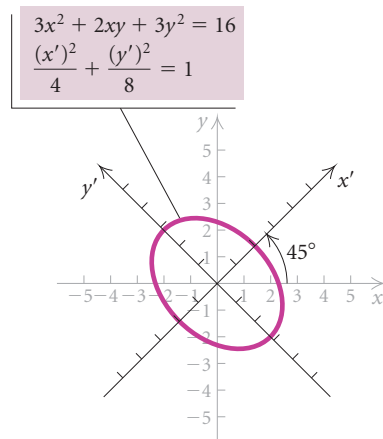

➔ Now Try Exercise 21.

EXAMPLE 4 Graph the equation $4x^2 - 24xy - 3y^2 - 156 = 0$.

Solution We have

$$A = 4, \quad B = -24, \quad \text{and} \quad C = -3, \quad \text{so}$$

$$B^2 - 4AC = (-24)^2 - 4 \cdot 4(-3) = 576 + 48 = 624.$$

Since the discriminant is positive, the graph is a hyperbola. To rotate the axes, we begin by determining θ :

$$\cot 2\theta = \frac{A - C}{B} = \frac{4 - (-3)}{-24} = -\frac{7}{24}.$$

Since $\cot 2\theta < 0$, we have $90^\circ < 2\theta < 180^\circ$. From the triangle at left, we see that $\cos 2\theta = -\frac{7}{25}$.

Using half-angle formulas, we have

$$\sin \theta = \sqrt{\frac{1 - \cos 2\theta}{2}} = \sqrt{\frac{1 - \left(-\frac{7}{25}\right)}{2}} = \frac{4}{5}$$

and

$$\cos \theta = \sqrt{\frac{1 + \cos 2\theta}{2}} = \sqrt{\frac{1 + \left(-\frac{7}{25}\right)}{2}} = \frac{3}{5}.$$

Substituting in the rotation of axes formulas gives us

$$x = x' \cos \theta - y' \sin \theta = \frac{3}{5}x' - \frac{4}{5}y'$$

and

$$y = x' \sin \theta + y' \cos \theta = \frac{4}{5}x' + \frac{3}{5}y'.$$

Now we substitute for x and y in the given equation:

$$4\left(\frac{3}{5}x' - \frac{4}{5}y'\right)^2 - 24\left(\frac{3}{5}x' - \frac{4}{5}y'\right)\left(\frac{4}{5}x' + \frac{3}{5}y'\right) - 3\left(\frac{4}{5}x' + \frac{3}{5}y'\right)^2 - 156 = 0.$$

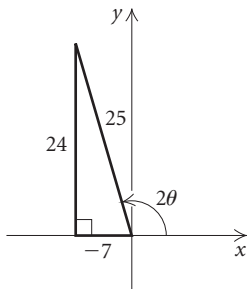

After simplifying, we have

$$\begin{aligned} 13(y')^2 - 12(x')^2 - 156 &= 0 \\ 13(y')^2 - 12(x')^2 &= 156 \\ \frac{(y')^2}{12} - \frac{(x')^2}{13} &= 1. \end{aligned}$$

The graph of this equation is a hyperbola with vertices $(0, -\sqrt{12})$ and $(0, \sqrt{12})$, or $(0, -2\sqrt{3})$ and $(0, 2\sqrt{3})$, on the y' -axis. Since we know that $\sin \theta = \frac{4}{5}$ and $0^\circ < \theta < 90^\circ$, we can use a calculator to find that $\theta \approx 53.1^\circ$. Thus the xy -axes are rotated through an angle of about 53.1° in order to obtain the $x'y'$ -axes. We sketch the graph.

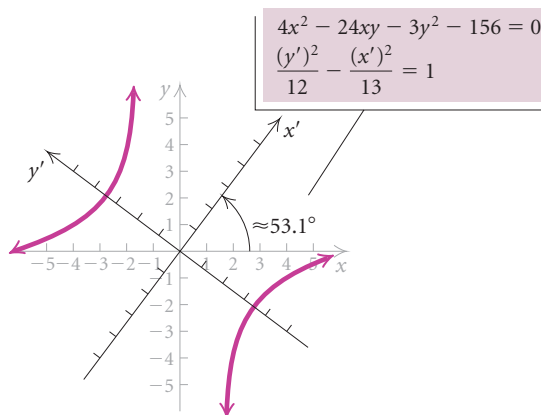

Now Try Exercise 35.

10.5

Exercise Set

For the given angle of rotation and coordinates of a point in the xy -coordinate system, find the coordinates of the point in the $x'y'$ -coordinate system.

1. $\theta = 45^\circ$, $(\sqrt{2}, -\sqrt{2})$
2. $\theta = 45^\circ$, $(-1, 3)$
3. $\theta = 30^\circ$, $(0, 2)$
4. $\theta = 60^\circ$, $(0, \sqrt{3})$

For the given angle of rotation and coordinates of a point in the $x'y'$ -coordinate system, find the coordinates of the point in the xy -coordinate system.

5. $\theta = 45^\circ$, $(1, -1)$
6. $\theta = 45^\circ$, $(-3\sqrt{2}, \sqrt{2})$
7. $\theta = 30^\circ$, $(2, 0)$
8. $\theta = 60^\circ$, $(-1, -\sqrt{3})$

Use the discriminant to determine whether the graph of the equation is an ellipse or a circle, a hyperbola, or a parabola.

9. $3x^2 - 5xy + 3y^2 - 2x + 7y = 0$
10. $5x^2 + 6xy - 4y^2 + x - 3y + 4 = 0$
11. $x^2 - 3xy - 2y^2 + 12 = 0$
12. $4x^2 + 7xy + 2y^2 - 3x + y = 0$
13. $4x^2 - 12xy + 9y^2 - 3x + y = 0$
14. $6x^2 + 5xy + 6y^2 + 15 = 0$
15. $2x^2 - 8xy + 7y^2 + x - 2y + 1 = 0$
16. $x^2 + 6xy + 9y^2 - 3x + 4y = 0$

17. $8x^2 - 7xy + 5y^2 - 17 = 0$

18. $x^2 + xy - y^2 - 4x + 3y - 2 = 0$

Graph the equation.

19. $4x^2 + 2xy + 4y^2 = 15$

20. $3x^2 + 10xy + 3y^2 + 8 = 0$

21. $x^2 - 10xy + y^2 + 36 = 0$

22. $x^2 + 2xy + y^2 + 4\sqrt{2}x - 4\sqrt{2}y = 0$

23. $x^2 - 2\sqrt{3}xy + 3y^2 - 12\sqrt{3}x - 12y = 0$

24. $13x^2 + 6\sqrt{3}xy + 7y^2 - 16 = 0$

25. $7x^2 + 6\sqrt{3}xy + 13y^2 - 32 = 0$

26. $x^2 + 4xy + y^2 - 9 = 0$

27. $11x^2 + 10\sqrt{3}xy + y^2 = 32$

28. $5x^2 - 8xy + 5y^2 = 81$

29. $\sqrt{2}x^2 + 2\sqrt{2}xy + \sqrt{2}y^2 - 8x + 8y = 0$

30. $x^2 + 2\sqrt{3}xy + 3y^2 - 8x + 8\sqrt{3}y = 0$

31. $x^2 + 6\sqrt{3}xy - 5y^2 + 8x - 8\sqrt{3}y - 48 = 0$

32. $3x^2 - 2xy + 3y^2 - 6\sqrt{2}x + 2\sqrt{2}y - 26 = 0$

33. $x^2 + xy + y^2 = 24$

34. $4x^2 + 3\sqrt{3}xy + y^2 = 55$

35. $4x^2 - 4xy + y^2 - 8\sqrt{5}x - 16\sqrt{5}y = 0$

36. $9x^2 - 24xy + 16y^2 - 400x - 300y = 0$

37. $11x^2 + 7xy - 13y^2 = 621$

38. $3x^2 + 4xy + 6y^2 = 28$

Skill Maintenance*Convert to radian measure.*

39. 120°

40. -315°

Convert to degree measure.

41. $\frac{\pi}{3}$

42. $\frac{3\pi}{4}$

Synthesis43. Solve this system of equations for x and y :

$$x' = x \cos \theta + y \sin \theta,$$

$$y' = y \cos \theta - x \sin \theta.$$

Show your work.

44. Show that substituting $x' \cos \theta - y' \sin \theta$ for x and $x' \sin \theta + y' \cos \theta$ for y in the equation

$$Ax^2 + Bxy + Cy^2 + Dx + Ey + F = 0$$

yields the equation

$$A'(x')^2 + B'x'y' + C'(y')^2 + D'x' + E'y' + F' = 0,$$
 where

$$A' = A \cos^2 \theta + B \sin \theta \cos \theta + C \sin^2 \theta,$$

$$B' = 2(C - A) \sin \theta \cos \theta + B(\cos^2 \theta - \sin^2 \theta),$$

$$C' = A \sin^2 \theta - B \sin \theta \cos \theta + C \cos^2 \theta,$$

$$D' = D \cos \theta + E \sin \theta,$$

$$E' = -D \sin \theta + E \cos \theta, \quad \text{and}$$

$$F' = F.$$

45. Show that $A + C = A' + C'$.46. Show that for any angle θ , the equation $x^2 + y^2 = r^2$ becomes $(x')^2 + (y')^2 = r^2$ when the rotation of axes formulas are applied.

Polar Equations of Conics

10.6

- ▶ Graph polar equations of conics.
- ▶ Convert from polar equations of conics to rectangular equations of conics.
- ▶ Find polar equations of conics.

In Sections 10.1–10.3, we saw that the parabola, the ellipse, and the hyperbola have different definitions in rectangular coordinates. When polar coordinates are used, we can give a single definition that applies to all three conics.

CONIC SECTIONS

REVIEW SECTIONS 10.1–10.3

An Alternative Definition of Conics

Let L be a fixed line (the **directrix**); let F be a fixed point (the **focus**) not on L ; and let e be a positive constant (the **eccentricity**). A **conic** is the set of all points P in the plane such that

$$\frac{PF}{PL} = e,$$

where PF is the distance from P to F and PL is the distance from P to L . The conic is a parabola if $e = 1$, an ellipse if $e < 1$, and a hyperbola if $e > 1$.

Note that if $e = 1$, then $PF = PL$ and the alternative definition of a parabola is identical to the definition presented in Section 10.1.

▶ Polar Equations of Conics

To derive equations for the conics in polar coordinates, we position the focus F at the pole and position the directrix L either perpendicular to the polar axis or parallel to it. In the figure below, we place L perpendicular to the polar axis and p units to the right of the focus, or pole.

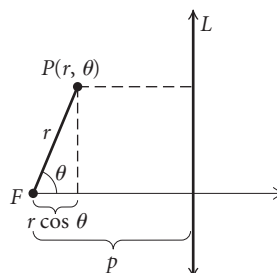

Note that $PL = p - r \cos \theta$. Then if P is any point on the conic, we have

$$\begin{aligned}\frac{PF}{PL} &= e \\ \frac{r}{p - r \cos \theta} &= e \\ r &= ep - er \cos \theta \\ r + er \cos \theta &= ep \\ r(1 + e \cos \theta) &= ep \\ r &= \frac{ep}{1 + e \cos \theta}.\end{aligned}$$

Thus we see that the polar equation of a conic with focus at the pole and directrix perpendicular to the polar axis and p units to the right of the pole is

$$r = \frac{ep}{1 + e \cos \theta},$$

where e is the eccentricity of the conic.

For an ellipse and a hyperbola, we can make the following statement regarding eccentricity.

For an ellipse and a hyperbola, the **eccentricity** e is given by

$$e = \frac{c}{a},$$

where c is the distance from the center to a focus and a is the distance from the center to a vertex.

EXAMPLE 1 Describe and graph the conic $r = \frac{18}{6 + 3 \cos \theta}$.

Solution We begin by dividing the numerator and the denominator by 6 to obtain a constant term of 1 in the denominator:

$$r = \frac{3}{1 + 0.5 \cos \theta}.$$

This equation is in the form

$$r = \frac{ep}{1 + e \cos \theta}$$

with $e = 0.5$. Since $e < 1$, the graph is an ellipse. Also, since $e = 0.5$ and $ep = 0.5p = 3$, we have $p = 6$. Thus the ellipse has a vertical directrix that lies 6 units to the right of the pole.

It follows that the major axis is horizontal and lies on the polar axis. The vertices are found by letting $\theta = 0$ and $\theta = \pi$. They are $(2, 0)$ and $(6, \pi)$. The center of the ellipse is at the midpoint of the segment connecting the vertices, or at $(2, \pi)$.

TECHNOLOGY CONNECTION

We can check the graph in Example 1 by graphing the equation in POLAR (POL) mode in a square window.

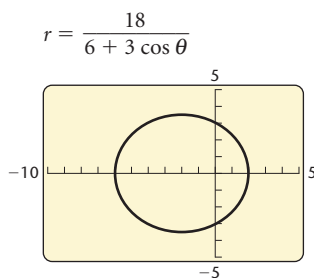

The length of the major axis is 8, so we have $2a = 8$, or $a = 4$. From the equation of the conic, we know that $e = 0.5$. Using the equation $e = c/a$, we can find that $c = 2$. Finally, using $a = 4$ and $c = 2$ in $b^2 = a^2 - c^2$ gives us

$$b^2 = 4^2 - 2^2 = 16 - 4 = 12$$

$$b = \sqrt{12}, \text{ or } 2\sqrt{3},$$

so the length of the minor axis is $\sqrt{12}$, or $2\sqrt{3}$.

We sketch the graph.

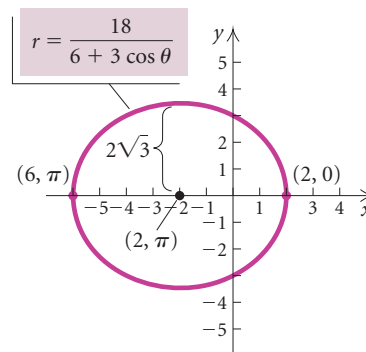

➔ Now Try Exercise 7.

Other derivations similar to the one on pp. 885 and 886 lead to the following result.

Polar Equations of Conics

A polar equation of any of the four forms

$$r = \frac{ep}{1 \pm e \cos \theta}, \quad r = \frac{ep}{1 \pm e \sin \theta}$$

is a conic section. The conic is a parabola if $e = 1$, an ellipse if $0 < e < 1$, and a hyperbola if $e > 1$.

The table below describes the polar equations of conics with a focus at the pole and the directrix either perpendicular to or parallel to the polar axis.

Equation	Description
$r = \frac{ep}{1 + e \cos \theta}$	Vertical directrix p units to the right of the pole (or focus)
$r = \frac{ep}{1 - e \cos \theta}$	Vertical directrix p units to the left of the pole (or focus)
$r = \frac{ep}{1 + e \sin \theta}$	Horizontal directrix p units above the pole (or focus)
$r = \frac{ep}{1 - e \sin \theta}$	Horizontal directrix p units below the pole (or focus)

EXAMPLE 2 Describe and graph the conic $r = \frac{10}{5 - 5 \sin \theta}$.

Solution We first divide the numerator and the denominator by 5:

$$r = \frac{2}{1 - \sin \theta}.$$

This equation is in the form

$$r = \frac{ep}{1 - e \sin \theta}$$

with $e = 1$, so the graph is a parabola. Since $e = 1$ and $ep = 1 \cdot p = 2$, we have $p = 2$. Thus the parabola has a horizontal directrix 2 units below the pole.

It follows that the parabola has a vertical axis of symmetry.

Since the directrix lies below the focus, or pole, the parabola opens up. The vertex is the midpoint of the segment of the axis of symmetry from the focus to the directrix. We find it by letting $\theta = 3\pi/2$. It is $(1, 3\pi/2)$.

To help determine the shape of the graph, we find two additional points. When $\theta = 0$, $r = 2$, and when $\theta = \pi$, $r = 2$, so we have the points $(2, 0)$ and $(2, \pi)$. We draw the graph.

TECHNOLOGY CONNECTION

We can check the graph in Example 2 by graphing the equation in POLAR mode in a square window.

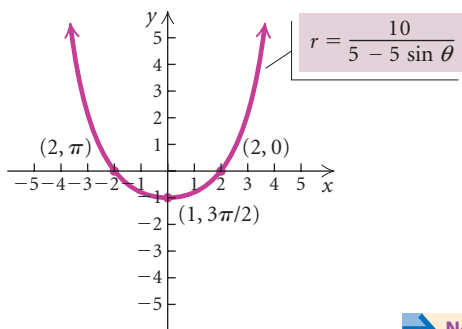
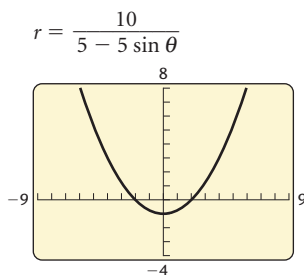

 Now Try Exercise 17.

EXAMPLE 3 Describe and graph the conic $r = \frac{4}{2 + 6 \sin \theta}$.

Solution We first divide the numerator and the denominator by 2:

$$r = \frac{2}{1 + 3 \sin \theta}.$$

This equation is in the form

$$r = \frac{ep}{1 + e \sin \theta}$$

with $e = 3$. Since $e > 1$, the graph is a hyperbola. We have $e = 3$ and $ep = 3p = 2$, so $p = \frac{2}{3}$. Thus the hyperbola has a horizontal directrix that lies $\frac{2}{3}$ unit above the pole.

It follows that the transverse axis is vertical. To find the vertices, we let $\theta = \pi/2$ and $\theta = 3\pi/2$. The vertices are $(1/2, \pi/2)$ and $(-1, 3\pi/2)$. The center of the hyperbola is the midpoint of the segment connecting the vertices,

or $(3/4, \pi/2)$. Thus the distance c from the center to a focus is $3/4$. Using $c = 3/4$, $e = 3$, and $e = c/a$, we have $a = 1/4$. Then since $c^2 = a^2 + b^2$, we have

$$b^2 = \left(\frac{3}{4}\right)^2 - \left(\frac{1}{4}\right)^2 = \frac{9}{16} - \frac{1}{16} = \frac{1}{2}$$

$$b = \frac{1}{\sqrt{2}}, \text{ or } \frac{\sqrt{2}}{2}.$$

Knowing the values of a and b allows us to sketch the asymptotes when we graph the hyperbola. We can also easily plot the points $(2, 0)$ and $(2, \pi)$ on the polar axis.

TECHNOLOGY CONNECTION

To check the graph in Example 3, we can graph the equation in POLAR mode and in DOT mode in a square window.

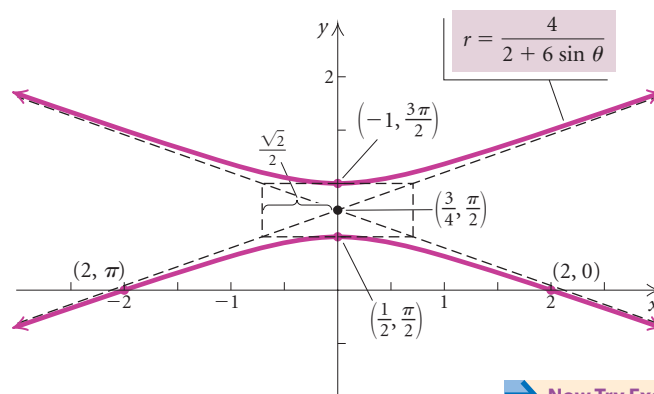
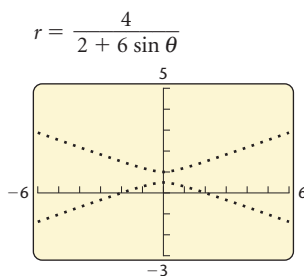

➔ Now Try Exercise 13.

► Converting from Polar Equations to Rectangular Equations

We can use the relationships between polar coordinates and rectangular coordinates that were developed in Section 8.4 to convert polar equations of conics to rectangular equations.

EXAMPLE 4 Convert to a rectangular equation: $r = \frac{2}{1 - \sin \theta}$.

Solution We have

$$r = \frac{2}{1 - \sin \theta}$$

$$r - r \sin \theta = 2$$

$$r = r \sin \theta + 2$$

$$\sqrt{x^2 + y^2} = y + 2$$

$$x^2 + y^2 = y^2 + 4y + 4$$

$$x^2 = 4y + 4, \text{ or}$$

$$x^2 - 4y - 4 = 0.$$

Multiplying by $1 - \sin \theta$

Substituting $\sqrt{x^2 + y^2}$ for r and y for $r \sin \theta$

Squaring both sides

This is the equation of a parabola, as we should have anticipated, since $e = 1$.

➔ Now Try Exercise 23.

► Finding Polar Equations of Conics

We can find the polar equation of a conic with a focus at the pole if we know its eccentricity and the equation of the directrix.

EXAMPLE 5 Find a polar equation of the conic with a focus at the pole, eccentricity $\frac{1}{3}$, and directrix $r = 2 \csc \theta$.

Solution The equation of the directrix can be written

$$r = \frac{2}{\sin \theta}, \quad \text{or} \quad r \sin \theta = 2.$$

This corresponds to the equation $y = 2$ in rectangular coordinates, so the directrix is a horizontal line 2 units above the polar axis. Using the table on p. 887, we see that the equation is of the form

$$r = \frac{ep}{1 + e \sin \theta}.$$

Substituting $\frac{1}{3}$ for e and 2 for p gives us

$$r = \frac{\frac{1}{3} \cdot 2}{1 + \frac{1}{3} \sin \theta} = \frac{\frac{2}{3}}{1 + \frac{1}{3} \sin \theta} = \frac{2}{3 + \sin \theta}.$$

 **Now Try Exercise 39.**

10.6 Exercise Set

In Exercises 1–6, match the equation with one of the graphs (a)–(f), which follow.

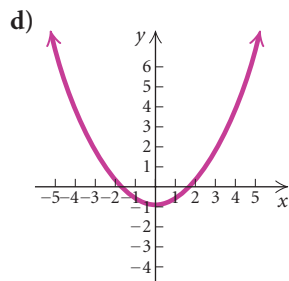
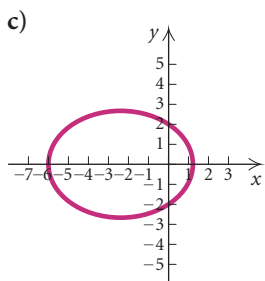
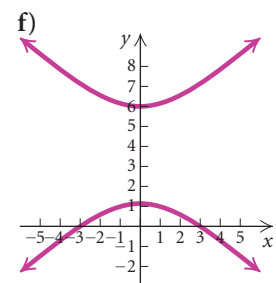
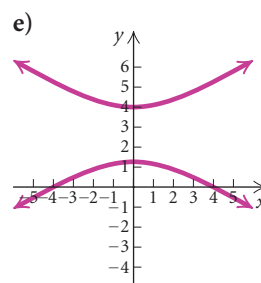
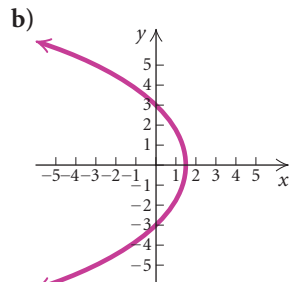
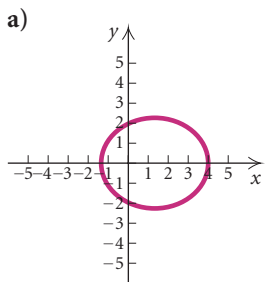

1. $r = \frac{3}{1 + \cos \theta}$

2. $r = \frac{4}{1 + 2 \sin \theta}$

3. $r = \frac{8}{4 - 2 \cos \theta}$

4. $r = \frac{12}{4 + 6 \sin \theta}$

5. $r = \frac{5}{3 - 3 \sin \theta}$

6. $r = \frac{6}{3 + 2 \cos \theta}$

For each equation:

- Tell whether the equation describes a parabola, an ellipse, or a hyperbola.
- State whether the directrix is vertical or horizontal and give its location in relation to the pole.
- Find the vertex or vertices.
- Graph the equation.

7. $r = \frac{1}{1 + \cos \theta}$

8. $r = \frac{4}{2 + \cos \theta}$

9. $r = \frac{15}{5 - 10 \sin \theta}$

10. $r = \frac{12}{4 + 8 \sin \theta}$

11. $r = \frac{8}{6 - 3 \cos \theta}$

12. $r = \frac{6}{2 + 2 \sin \theta}$

13. $r = \frac{20}{10 + 15 \sin \theta}$

14. $r = \frac{10}{8 - 2 \cos \theta}$

15. $r = \frac{9}{6 + 3 \cos \theta}$

16. $r = \frac{4}{3 - 9 \sin \theta}$

17. $r = \frac{3}{2 - 2 \sin \theta}$

18. $r = \frac{12}{3 + 9 \cos \theta}$

19. $r = \frac{4}{2 - \cos \theta}$

20. $r = \frac{5}{1 - \sin \theta}$

21. $r = \frac{7}{2 + 10 \sin \theta}$

22. $r = \frac{3}{8 - 4 \cos \theta}$

- 23.–38. Convert the equations in Exercises 7–22 to rectangular equations.

Find a polar equation of the conic with a focus at the pole and the given eccentricity and directrix.

39. $e = 2, r = 3 \csc \theta$

40. $e = \frac{2}{3}, r = -\sec \theta$

41. $e = 1, r = 4 \sec \theta$

42. $e = 3, r = 2 \csc \theta$

43. $e = \frac{1}{2}, r = -2 \sec \theta$

44. $e = 1, r = 4 \csc \theta$

45. $e = \frac{3}{4}, r = 5 \csc \theta$

46. $e = \frac{4}{5}, r = 2 \sec \theta$

47. $e = 4, r = -2 \csc \theta$

48. $e = 3, r = 3 \csc \theta$

Skill Maintenance

For $f(x) = (x - 3)^2 + 4$, find each of the following.

49. $f(t)$

50. $f(2t)$

51. $f(t - 1)$

52. $f(t + 2)$

Synthesis

Parabolic Orbit. Suppose that a comet travels in a parabolic orbit with the sun as its focus. Position a polar coordinate system with the pole at the sun and the axis of the orbit perpendicular to the polar axis. When the comet is the given distance from the sun, the segment from the comet to the sun makes the given angle with the polar axis. Find a polar equation of the orbit, assuming that the directrix lies above the pole.

53. 100 million miles, $\frac{\pi}{6}$

54. 120 million miles, $\frac{\pi}{4}$

Parametric Equations

10.7

- ▶ Graph parametric equations.
- ▶ Determine an equivalent rectangular equation for parametric equations.
- ▶ Determine parametric equations for a rectangular equation.
- ▶ Solve applied problems involving projectile motion.

▶ Graphing Parametric Equations

We have graphed *plane curves* that are composed of sets of ordered pairs (x, y) in the rectangular coordinate plane. Now we discuss a way to represent plane curves in which x and y are functions of a third variable, t .

EXAMPLE 1 Graph the curve represented by the equations

$$x = \frac{1}{2}t, \quad y = t^2 - 3; \quad -3 \leq t \leq 3.$$

Solution We can choose values for t between -3 and 3 and find the corresponding values of x and y . When $t = -3$, we have

$$x = \frac{1}{2}(-3) = -\frac{3}{2}, \quad y = (-3)^2 - 3 = 6.$$

The table below lists other ordered pairs. We plot these points and then draw the curve.

t	x	y	(x, y)
-3	$-\frac{3}{2}$	6	$(-\frac{3}{2}, 6)$
-2	-1	1	$(-1, 1)$
-1	$-\frac{1}{2}$	-2	$(-\frac{1}{2}, -2)$
0	0	-3	$(0, -3)$
1	$\frac{1}{2}$	-2	$(\frac{1}{2}, -2)$
2	1	1	$(1, 1)$
3	$\frac{3}{2}$	6	$(\frac{3}{2}, 6)$

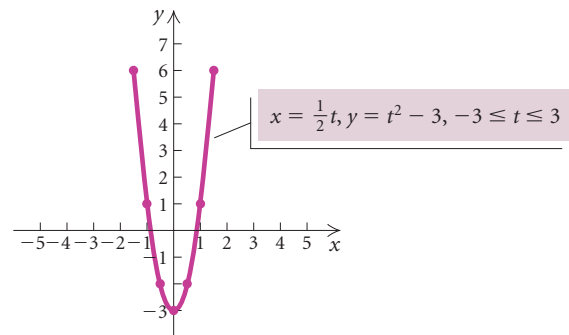

The curve above appears to be part of a parabola. Let's verify this by finding the equivalent rectangular equation. Solving $x = \frac{1}{2}t$ for t , we get $t = 2x$. Substituting $2x$ for t in $y = t^2 - 3$, we have

$$y = (2x)^2 - 3 = 4x^2 - 3.$$

This is a quadratic equation. Hence its graph is a parabola. The curve is part of the parabola $y = 4x^2 - 3$. Since $-3 \leq t \leq 3$ and $x = \frac{1}{2}t$, we must include the restriction $-\frac{3}{2} \leq x \leq \frac{3}{2}$ when we write the equivalent rectangular equation:

$$y = 4x^2 - 3, \quad -\frac{3}{2} \leq x \leq \frac{3}{2}.$$

The equations $x = \frac{1}{2}t$ and $y = t^2 - 3$ are **parametric equations** for the curve. The variable t is the **parameter**. When we write the corresponding rectangular equation, we say that we **eliminate the parameter**.

Parametric Equations

If f and g are continuous functions of t on an interval I , then the set of ordered pairs (x, y) such that $x = f(t)$ and $y = g(t)$ is a **plane curve**. The equations $x = f(t)$ and $y = g(t)$ are **parametric equations** for the curve. The variable t is the **parameter**.

► Determining a Rectangular Equation for Given Parametric Equations

EXAMPLE 2 Find a rectangular equation equivalent to each pair of parametric equations.

a) $x = t^2, y = t - 1; -1 \leq t \leq 4$

b) $x = \sqrt{t}, y = 2t + 3; 0 \leq t \leq 3$

Solution

- a) We can first solve either equation for t . We choose the equation $y = t - 1$:

$$y = t - 1$$

$$y + 1 = t.$$

We then substitute $y + 1$ for t in $x = t^2$:

$$x = t^2$$

$$x = (y + 1)^2. \quad \text{Substituting}$$

This is an equation of a parabola that opens to the right. Given that $-1 \leq t \leq 4$, we have the corresponding restrictions on x and y : $0 \leq x \leq 16$ and $-2 \leq y \leq 3$. Thus the equivalent rectangular equation is

$$x = (y + 1)^2; \quad 0 \leq x \leq 16.$$

- b) We first solve $x = \sqrt{t}$ for t :

$$x = \sqrt{t}$$

$$x^2 = t.$$

Then we substitute x^2 for t in $y = 2t + 3$:

$$y = 2t + 3$$

$$y = 2x^2 + 3. \quad \text{Substituting}$$

When $0 \leq t \leq 3$, we have $0 \leq x \leq \sqrt{3}$. The equivalent rectangular equation is

$$y = 2x^2 + 3; \quad 0 \leq x \leq \sqrt{3}.$$

 **Now Try Exercise 5.**

TECHNOLOGY CONNECTION

We can graph parametric equations on a graphing calculator set in PARAMETRIC mode. The window dimensions include minimum and maximum values for x , y , and t . For the parametric equations in Example 2(b), we can use the settings shown below.

WINDOW

$$T_{\min} = 0$$

$$T_{\max} = 3$$

$$T_{\text{step}} = .1$$

$$X_{\min} = -3$$

$$X_{\max} = 3$$

$$X_{\text{scl}} = 1$$

$$Y_{\min} = -2$$

$$Y_{\max} = 10$$

$$Y_{\text{scl}} = 1$$

$$x = \sqrt{t}, \quad y = 2t + 3;$$

$$0 \leq t \leq 3$$

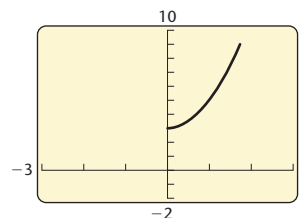

EXAMPLE 3 Find a rectangular equation equivalent to each pair of parametric equations.

a) $x = \cos t$, $y = \sin t$; $0 \leq t \leq 2\pi$

b) $x = 5 \cos t$, $y = 3 \sin t$; $0 \leq t \leq 2\pi$

Solution

a) First, we square both sides of each parametric equation:

$$x^2 = \cos^2 t \quad \text{and} \quad y^2 = \sin^2 t.$$

This allows us to use the trigonometric identity $\sin^2 \theta + \cos^2 \theta = 1$. Substituting, we get

$$x^2 + y^2 = 1.$$

This is the equation of a circle with center $(0, 0)$ and radius 1.

b) First, we solve for $\cos t$ and $\sin t$ in the parametric equations:

$$x = 5 \cos t \quad y = 3 \sin t$$

$$\frac{x}{5} = \cos t, \quad \frac{y}{3} = \sin t.$$

Using the identity $\sin^2 \theta + \cos^2 \theta = 1$, we can substitute to eliminate the parameter:

$$\begin{aligned} \sin^2 t + \cos^2 t &= 1 \\ \left(\frac{y}{3}\right)^2 + \left(\frac{x}{5}\right)^2 &= 1 \quad \text{Substituting} \\ \frac{x^2}{25} + \frac{y^2}{9} &= 1. \end{aligned}$$

This is the equation of an ellipse centered at the origin with vertices at $(5, 0)$ and $(-5, 0)$.

 **Now Try Exercises 13 and 15.**

► Determining Parametric Equations for a Given Rectangular Equation

Many sets of parametric equations can represent the same plane curve. In fact, there are infinitely many such equations.

EXAMPLE 4 Find three sets of parametric equations for the parabola

$$y = 4 - (x + 3)^2.$$

Solution

If $x = t$, then $y = 4 - (t + 3)^2$, or $-t^2 - 6t - 5$.

If $x = t - 3$, then $y = 4 - (t - 3 + 3)^2$, or $4 - t^2$.

If $x = \frac{t}{3}$, then $y = 4 - \left(\frac{t}{3} + 3\right)^2$, or $-\frac{t^2}{9} - 2t - 5$.

 **Now Try Exercise 21.**

► Applications

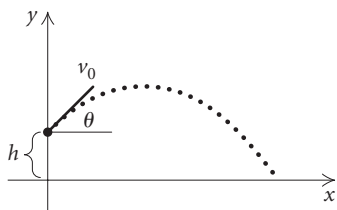

The motion of an object that is propelled upward can be described with parametric equations. Such motion is called **projectile motion**. It can be shown using more advanced mathematics that, neglecting air resistance, the following equations describe the path of a projectile propelled upward at an angle θ with the horizontal from a height h , in feet, at an initial speed v_0 , in feet per second:

$$x = (v_0 \cos \theta)t, \quad y = h + (v_0 \sin \theta)t - 16t^2.$$

We can use these equations to determine the location of the object at time t , in seconds.

EXAMPLE 5 *Projectile Motion.* A baseball is thrown from a height of 6 ft with an initial speed of 100 ft/sec at an angle of 45° with the horizontal.

- Find parametric equations that give the position of the ball at time t , in seconds.
- Find the height of the ball after 1 sec, 2 sec, and 3 sec.
- Determine how long the ball is in the air.
- Determine the horizontal distance that the ball travels.
- Find the maximum height of the ball.

Solution

- a) We substitute 6 for h , 100 for v_0 , and 45° for θ in the equations above:

$$\begin{aligned} x &= (v_0 \cos \theta)t \\ &= (100 \cos 45^\circ)t \\ &= \left(100 \cdot \frac{\sqrt{2}}{2}\right)t = 50\sqrt{2}t; \end{aligned}$$

$$\begin{aligned} y &= h + (v_0 \sin \theta)t - 16t^2 \\ &= 6 + (100 \sin 45^\circ)t - 16t^2 \\ &= 6 + \left(100 \cdot \frac{\sqrt{2}}{2}\right)t - 16t^2 \\ &= 6 + 50\sqrt{2}t - 16t^2. \end{aligned}$$

- b) The height of the ball at time t is represented by y .

$$\text{When } t = 1, y = 6 + 50\sqrt{2}(1) - 16(1)^2 \approx 60.7 \text{ ft.}$$

$$\text{When } t = 2, y = 6 + 50\sqrt{2}(2) - 16(2)^2 \approx 83.4 \text{ ft.}$$

$$\text{When } t = 3, y = 6 + 50\sqrt{2}(3) - 16(3)^2 \approx 74.1 \text{ ft.}$$

- c) The ball hits the ground when $y = 0$. Thus, in order to determine how long the ball is in the air, we solve the equation $y = 0$:

$$6 + 50\sqrt{2}t - 16t^2 = 0$$

$$-16t^2 + 50\sqrt{2}t + 6 = 0 \quad \text{Standard form}$$

$$t = \frac{-50\sqrt{2} \pm \sqrt{(50\sqrt{2})^2 - 4(-16)(6)}}{2(-16)}$$

Using the quadratic formula

$$t \approx -0.1 \quad \text{or} \quad t \approx 4.5.$$

The negative value for t has no meaning in this application. Thus we determine that the ball is in the air for about 4.5 sec.

- d) Since the ball is in the air for about 4.5 sec, the horizontal distance that it travels is given by

$$x = 50\sqrt{2}(4.5) \approx 318.2 \text{ ft.}$$

- e) To find the maximum height of the ball, we find the maximum value of y . This occurs at the vertex of the quadratic function represented by y . At the vertex, we have

$$t = -\frac{b}{2a} = -\frac{50\sqrt{2}}{2(-16)} \approx 2.2.$$

When $t = 2.2$,

$$y = 6 + 50\sqrt{2}(2.2) - 16(2.2)^2 \approx 84.1 \text{ ft.}$$

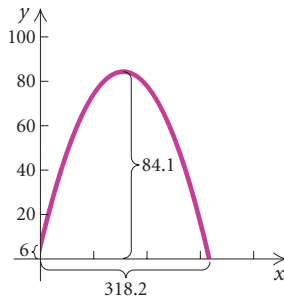

Now Try Exercise 25.

The path of a fixed point on the circumference of a circle as it rolls along a line is called a **cycloid**. For example, a point on the rim of a bicycle wheel traces a cycloid curve.

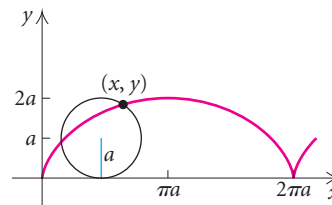

The parametric equations of a cycloid are

$$x = a(t - \sin t), \quad y = a(1 - \cos t),$$

where a is the radius of the circle that traces the curve and t is in radian measure. The graph of the cycloid described by the parametric equations

$$x = 3(t - \sin t), \quad y = 3(1 - \cos t); \quad 0 \leq t \leq 6\pi$$

is shown below.

STUDY TIP

Prepare for each chapter test by rereading the text, reviewing your homework, studying the concepts and procedures in the Study Guide at the end of the chapter, and doing the review exercises. Then take the chapter test at the end of the chapter.

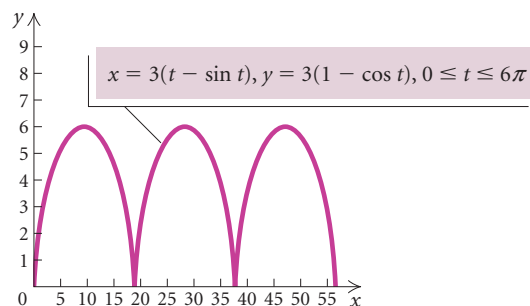

10.7

Exercise Set

Graph the plane curve given by the parametric equations. Then find an equivalent rectangular equation.

- $x = \frac{1}{2}t, y = 6t - 7; -1 \leq t \leq 6$
- $x = t, y = 5 - t; -2 \leq t \leq 3$
- $x = 4t^2, y = 2t; -1 \leq t \leq 1$
- $x = \sqrt{t}, y = 2t + 3; 0 \leq t \leq 8$

Find a rectangular equation equivalent to the given pair of parametric equations.

- $x = t^2, y = \sqrt{t}; 0 \leq t \leq 4$
- $x = t^3 + 1, y = t; -3 \leq t \leq 3$
- $x = t + 3, y = \frac{1}{t+3}; -2 \leq t \leq 2$
- $x = 2t^3 + 1, y = 2t^3 - 1; -4 \leq t \leq 4$
- $x = 2t - 1, y = t^2; -3 \leq t \leq 3$
- $x = \frac{1}{3}t, y = t; -5 \leq t \leq 5$
- $x = e^{-t}, y = e^t; -\infty < t < \infty$
- $x = 2 \ln t, y = t^2; 0 < t < \infty$
- $x = 3 \cos t, y = 3 \sin t; 0 \leq t \leq 2\pi$
- $x = 2 \cos t, y = 4 \sin t; 0 \leq t \leq 2\pi$
- $x = \cos t, y = 2 \sin t; 0 \leq t \leq 2\pi$
- $x = 2 \cos t, y = 2 \sin t; 0 \leq t \leq 2\pi$
- $x = \sec t, y = \cos t; -\frac{\pi}{2} < t < \frac{\pi}{2}$
- $x = \sin t, y = \csc t; 0 < t < \pi$
- $x = 1 + 2 \cos t, y = 2 + 2 \sin t; 0 \leq t \leq 2\pi$
- $x = 2 + \sec t, y = 1 + 3 \tan t; 0 < t < \frac{\pi}{2}$

Find two sets of parametric equations for the rectangular equation.

- $y = 4x - 3$
- $y = x^2 - 1$
- $y = (x - 2)^2 - 6x$
- $y = x^3 + 3$

- Projectile Motion.** A ball is thrown from a height of 7 ft with an initial speed of 80 ft/sec at an angle of 30° with the horizontal.
 - Find parametric equations that give the position of the ball at time t , in seconds.
 - Find the height of the ball after 1 sec and after 2 sec.
 - Determine how long the ball is in the air.
 - Determine the horizontal distance that the ball travels.
 - Find the maximum height of the ball.
- Projectile Motion.** A projectile is launched from the ground with an initial speed of 200 ft/sec at an angle of 60° with the horizontal.
 - Find parametric equations that give the position of the projectile at time t , in seconds.
 - Find the height of the projectile after 4 sec and after 8 sec.
 - Determine how long the projectile is in the air.
 - Determine the horizontal distance that the projectile travels.
 - Find the maximum height of the projectile.

Skill Maintenance

Graph.

- $y = x^3$
- $x = y^3$
- $f(x) = \sqrt{x - 2}$
- $f(x) = \frac{3}{x^2 - 1}$

Synthesis

- Consider the curve described by

$$x = 3 \cos t, \quad y = 3 \sin t; \quad 0 \leq t \leq 2\pi.$$
 As t increases, the path of the curve is generated in the counterclockwise direction. How can this set of equations be changed so that the curve is generated in the clockwise direction?
- Find an equivalent rectangular equation for the curve described by

$$x = \cos^3 t, \quad y = \sin^3 t; \quad 0 \leq t \leq 2\pi.$$

Chapter 10 Summary and Review

STUDY GUIDE

KEY TERMS AND CONCEPTS

EXAMPLES

SECTION 10.1: THE PARABOLA

Standard Equation of a Parabola with Vertex (h, k) and Vertical Axis of Symmetry

The standard equation of a parabola with vertex (h, k) and vertical axis of symmetry is

$$(x - h)^2 = 4p(y - k),$$

where the vertex is (h, k) , the focus is $(h, k + p)$, and the directrix is $y = k - p$.

The parabola opens up if $p > 0$. It opens down if $p < 0$.

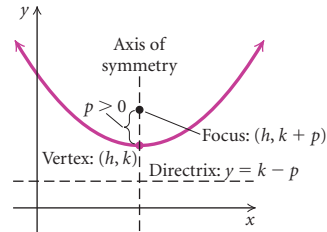

(When $p < 0$, the parabola opens down.)

See also Examples 1 and 3 on pp. 834 and 835.

Standard Equation of a Parabola with Vertex (h, k) and Horizontal Axis of Symmetry

The standard equation of a parabola with vertex (h, k) and horizontal axis of symmetry is

$$(y - k)^2 = 4p(x - h),$$

where the vertex is (h, k) , the focus is $(h + p, k)$, and the directrix is $x = h - p$.

The parabola opens to the right if $p > 0$. It opens to the left if $p < 0$.

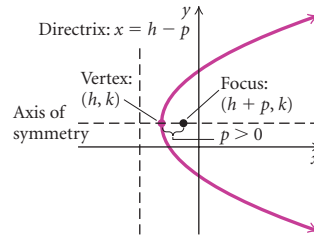

(When $p < 0$, the parabola opens to the left.)

See also Examples 2 and 4 on pp. 834 and 836.

SECTION 10.2: THE CIRCLE AND THE ELLIPSE

Standard Equation of a Circle

The standard equation of a circle with center (h, k) and radius r is

$$(x - h)^2 + (y - k)^2 = r^2.$$

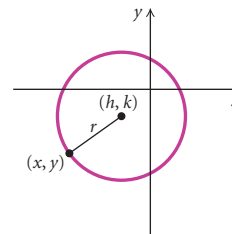

See also Example 1 on p. 840.

Standard Equation of an Ellipse with Center at the Origin

Major Axis Horizontal

$$\frac{x^2}{a^2} + \frac{y^2}{b^2} = 1, \quad a > b > 0$$

Vertices: $(-a, 0), (a, 0)$

y -intercepts: $(0, -b), (0, b)$

Foci: $(-c, 0), (c, 0)$, where $c^2 = a^2 - b^2$

Major Axis Vertical

$$\frac{x^2}{b^2} + \frac{y^2}{a^2} = 1, \quad a > b > 0$$

Vertices: $(0, -a), (0, a)$

x -intercepts: $(-b, 0), (b, 0)$

Foci: $(0, -c), (0, c)$, where $c^2 = a^2 - b^2$

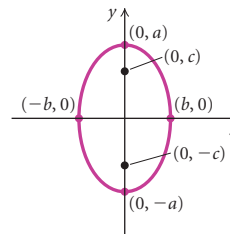
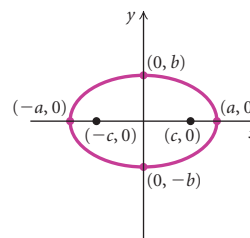

See also Examples 2 and 3 on pp. 844 and 845.

Standard Equation of an Ellipse with Center at (h, k)

Major Axis Horizontal

$$\frac{(x - h)^2}{a^2} + \frac{(y - k)^2}{b^2} = 1, \quad a > b > 0$$

Vertices: $(h - a, k), (h + a, k)$

Length of minor axis: $2b$

Foci: $(h - c, k), (h + c, k)$,

where $c^2 = a^2 - b^2$

Major Axis Vertical

$$\frac{(x - h)^2}{b^2} + \frac{(y - k)^2}{a^2} = 1, \quad a > b > 0$$

Vertices: $(h, k - a), (h, k + a)$

Length of minor axis: $2b$

Foci: $(h, k - c), (h, k + c)$,

where $c^2 = a^2 - b^2$

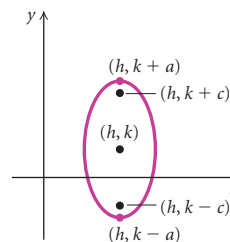
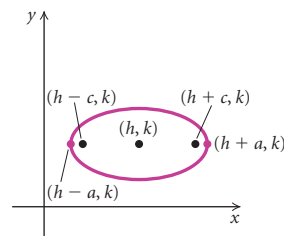

See also Example 4 on p. 846.

SECTION 10.3: THE HYPERBOLA

Standard Equation of a Hyperbola with Center at the Origin*Transverse Axis Horizontal*

$$\frac{x^2}{a^2} - \frac{y^2}{b^2} = 1$$

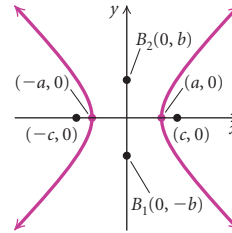
Vertices: $(-a, 0), (a, 0)$ Asymptotes: $y = -\frac{b}{a}x, y = \frac{b}{a}x$ Foci: $(-c, 0), (c, 0)$, where $c^2 = a^2 + b^2$ *Transverse Axis Vertical*

$$\frac{y^2}{a^2} - \frac{x^2}{b^2} = 1$$

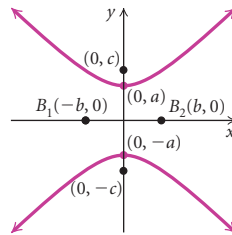
Vertices: $(0, -a), (0, a)$ Asymptotes: $y = -\frac{a}{b}x, y = \frac{a}{b}x$ Foci: $(0, -c), (0, c)$, where $c^2 = a^2 + b^2$ 

See also Examples 1 and 2 on p. 853.

Standard Equation of a Hyperbola with Center at (h, k) *Transverse Axis Horizontal*

$$\frac{(x - h)^2}{a^2} - \frac{(y - k)^2}{b^2} = 1$$

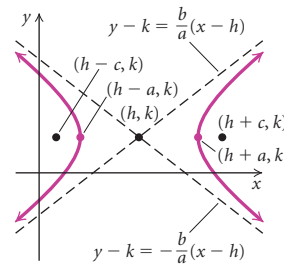
Vertices: $(h - a, k), (h + a, k)$ Asymptotes: $y - k = \frac{b}{a}(x - h),$
 $y - k = -\frac{b}{a}(x - h)$ Foci: $(h - c, k), (h + c, k),$
where $c^2 = a^2 + b^2$ *Transverse Axis Vertical*

$$\frac{(y - k)^2}{a^2} - \frac{(x - h)^2}{b^2} = 1$$

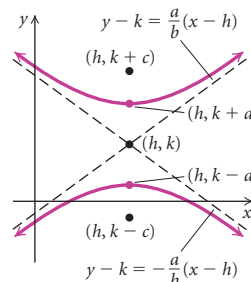
Vertices: $(h, k - a), (h, k + a)$ Asymptotes: $y - k = \frac{a}{b}(x - h),$
 $y - k = -\frac{a}{b}(x - h)$ Foci: $(h, k - c), (h, k + c),$
where $c^2 = a^2 + b^2$ 

See also Example 3 on p. 855.

SECTION 10.4: NONLINEAR SYSTEMS OF EQUATIONS AND INEQUALITIES

Substitution or elimination can be used to solve **systems of equations containing at least one nonlinear equation.**

$$\begin{aligned} \text{Solve: } x^2 - y &= 2, & (1) & \quad \text{The graph is a parabola.} \\ x - y &= -4. & (2) & \quad \text{The graph is a line.} \end{aligned}$$

$$\begin{aligned} x &= y - 4 & \text{Solving equation (2) for } x \\ (y - 4)^2 - y &= 2 & \text{Substituting for } x \\ & & \text{in equation (1)} \end{aligned}$$

$$\begin{aligned} y^2 - 8y + 16 - y &= 2 \\ y^2 - 9y + 14 &= 0 \\ (y - 2)(y - 7) &= 0 \\ y - 2 = 0 & \text{ or } y - 7 = 0 \\ y = 2 & \text{ or } y = 7 \end{aligned}$$

$$\text{If } y = 2, \text{ then } x = 2 - 4 = -2.$$

$$\text{If } y = 7, \text{ then } x = 7 - 4 = 3.$$

The pairs $(-2, 2)$ and $(3, 7)$ check, so they are the solutions.

Some applied problems translate to a nonlinear system of equations.

See Example 5 on p. 867.

To graph a **nonlinear system of inequalities**, graph each inequality in the system and then shade the region where their solution sets overlap.

To find the point(s) of intersection of the graphs of the related equations, solve the system of equations composed of those equations.

$$\begin{aligned} \text{Graph: } x^2 - y &\leq 2, \\ x - y &> -4. \end{aligned}$$

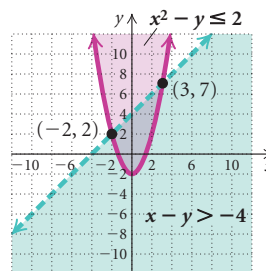

To find the points of intersection of the graphs of the related equations, solve the system of equations

$$\begin{aligned} x^2 - y &= 2, \\ x - y &= -4. \end{aligned}$$

We saw in the example at the top of this page that these points are $(-2, 2)$ and $(3, 7)$.

SECTION 10.5: ROTATION OF AXES

To eliminate the xy -term from the equation

$$Ax^2 + Bxy + Cy^2 + Dx + Ey + F = 0,$$

$$B \neq 0,$$

select an angle θ such that

$$\cot 2\theta = \frac{A - C}{B}, \quad 0^\circ < 2\theta < 180^\circ,$$

and use the rotation of axes formulas below.

If the x - and y -axes are rotated about the origin through a positive acute angle θ , then the coordinates (x, y) and (x', y') of a point P in the xy - and $x'y'$ -coordinate systems are related by the following formulas:

$$\begin{aligned}x' &= x \cos \theta + y \sin \theta, \\y' &= -x \sin \theta + y \cos \theta; \\x &= x' \cos \theta - y' \sin \theta, \\y &= x' \sin \theta + y' \cos \theta.\end{aligned}$$

The expression $B^2 - 4AC$ is the **discriminant** of the equation

$$Ax^2 + Bxy + Cy^2 + Dx + Ey + F = 0.$$

The graph of the equation

$$Ax^2 + Bxy + Cy^2 + Dx + Ey + F = 0$$

is, except in degenerate cases,

1. an ellipse or a circle if $B^2 - 4AC < 0$,
2. a hyperbola if $B^2 - 4AC > 0$, and
3. a parabola if $B^2 - 4AC = 0$.

See Example 2 on p. 879.

Use the discriminant to determine whether the equation is an ellipse or a circle, a hyperbola, or a parabola.

- a) $x^2 - 2xy - 3y^2 + 5x + 1 = 0$
- b) $3x^2 + 6xy + 3y^2 + 4x - 7y + 2 = 0$
- c) $5x^2 + 3xy + y^2 - 8 = 0$

- a) $A = 1, B = -2$, and $C = -3$, so

$$B^2 - 4AC = (-2)^2 - 4 \cdot 1 \cdot (-3) = 4 + 12 = 16 > 0.$$

The graph is a hyperbola.

- b) $A = 3, B = 6$, and $C = 3$, so

$$B^2 - 4AC = 6^2 - 4 \cdot 3 \cdot 3 = 36 - 36 = 0.$$

The graph is a parabola.

- c) $A = 5, B = 3$, and $C = 1$, so

$$B^2 - 4AC = 3^2 - 4 \cdot 5 \cdot 1 = 9 - 20 = -11 < 0.$$

The graph is an ellipse or a circle.

SECTION 10.6: POLAR EQUATIONS OF CONICS

A polar equation of any of the four forms

$$r = \frac{ep}{1 \pm e \cos \theta}, \quad r = \frac{ep}{1 \pm e \sin \theta}$$

is a conic section. The conic is a parabola if $e = 1$, an ellipse if $0 < e < 1$, and a hyperbola if $e > 1$.

Equation	Description
$r = \frac{ep}{1 + e \cos \theta}$	Vertical directrix p units to the right of the pole (or focus)
$r = \frac{ep}{1 - e \cos \theta}$	Vertical directrix p units to the left of the pole (or focus)
$r = \frac{ep}{1 + e \sin \theta}$	Horizontal directrix p units above the pole (or focus)
$r = \frac{ep}{1 - e \sin \theta}$	Horizontal directrix p units below the pole (or focus)

We can use the relationships between polar coordinates and rectangular coordinates to **convert polar equations of conics to rectangular equations.**

Describe and graph the conic

$$r = \frac{3}{3 + \cos \theta}$$

We first divide the numerator and the denominator by 3:

$$r = \frac{1}{1 + \frac{1}{3} \cos \theta}$$

The equation is of the form

$$r = \frac{ep}{1 + e \cos \theta},$$

with $e = \frac{1}{3}$. Since $0 < \frac{1}{3} < 1$, the graph is an ellipse.

Since $e = \frac{1}{3}$ and $ep = \frac{1}{3} \cdot p = 1$, we have $p = 3$. Thus the ellipse has a vertical directrix 3 units to the right of the pole. We find the vertices by letting $\theta = 0$ and $\theta = \pi$. When $\theta = 0$,

$$r = \frac{3}{3 + \cos 0} = \frac{3}{3 + 1} = \frac{3}{4}$$

When $\theta = \pi$,

$$r = \frac{3}{3 + \cos \pi} = \frac{3}{3 - 1} = \frac{3}{2}$$

The vertices are $(\frac{3}{4}, 0)$ and $(\frac{3}{2}, \pi)$.

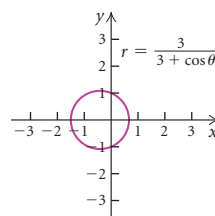

Convert to a rectangular equation:

$$r = \frac{4}{3 - \cos \theta}$$

We have

$$r = \frac{4}{3 - \cos \theta}$$

$$3r - r \cos \theta = 4$$

Multiplying by
 $3 - \cos \theta$

$$3r = r \cos \theta + 4$$

$$3\sqrt{x^2 + y^2} = x + 4$$

Substituting
Squaring both
sides

$$9x^2 + 9y^2 = x^2 + 8x + 16$$

$$8x^2 + 9y^2 - 8x - 16 = 0.$$

SECTION 10.7: PARAMETRIC EQUATIONS

Parametric Equations

If f and g are continuous functions of t on an interval I , then the set of ordered pairs (x, y) such that $x = f(t)$ and $y = g(t)$ is a **plane curve**. The equations $x = f(t)$ and $y = g(t)$ are **parametric equations** for the curve. The variable t is the **parameter**.

Graph the plane curve given by the following pair of parametric equations. Then find an equivalent rectangular equation.

$$x = \frac{3}{2}t, \quad y = 2t - 1; \quad -2 \leq t \leq 3$$

We can choose values of t between -2 and 3 and find the corresponding values of x and y .

t	x	y	(x, y)
-2	-3	-5	$(-3, -5)$
-1	$-\frac{3}{2}$	-3	$(-\frac{3}{2}, -3)$
0	0	-1	$(0, -1)$
1	$\frac{3}{2}$	1	$(\frac{3}{2}, 1)$
2	3	3	$(3, 3)$
3	$\frac{9}{2}$	5	$(\frac{9}{2}, 5)$

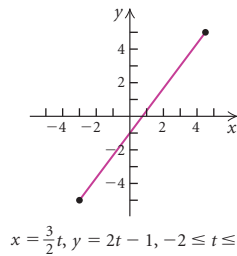

Solving $x = \frac{3}{2}t$ for t , we have $\frac{2}{3}x = t$. Then we have

$$y = 2t - 1 = 2 \cdot \frac{2}{3}x - 1 = \frac{4}{3}x - 1.$$

Since $-2 \leq t \leq 3$ and $x = \frac{3}{2}t$, we have $-3 \leq x \leq \frac{9}{2}$. Thus we have the equivalent rectangular equation

$$y = \frac{4}{3}x - 1; \quad -3 \leq x \leq \frac{9}{2}.$$

REVIEW EXERCISES

Determine whether the statement is true or false.

- The graph of $x + y^2 = 1$ is a parabola that opens to the left. [10.1]
- The graph of $\frac{(x - 2)^2}{4} + \frac{(y + 3)^2}{9} = 1$ is an ellipse with center $(-2, 3)$. [10.2]
- A parabola must open up or down. [10.1]
- The major axis of the ellipse $\frac{x^2}{4} + \frac{y^2}{16} = 1$ is vertical. [10.2]
- The graph of a nonlinear system of equations shows all the solutions of the system of equations. [10.4]

In Exercises 6–13, match the equation with one of the graphs (a)–(h), which follow.

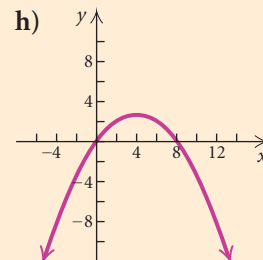
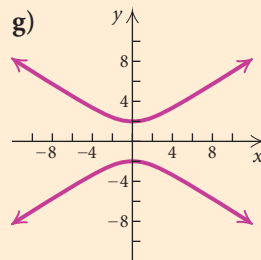
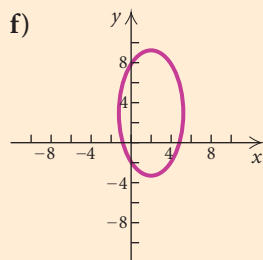
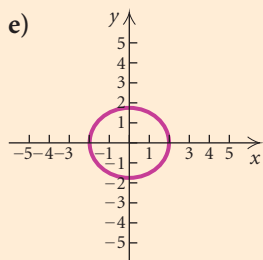
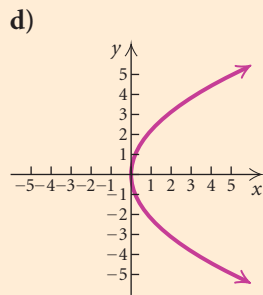
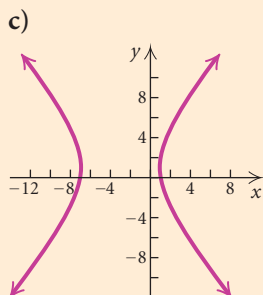
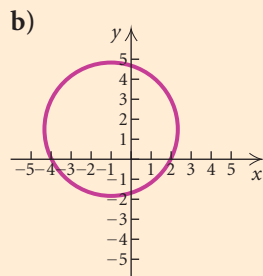
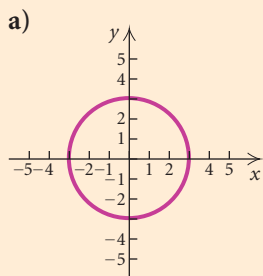

- $y^2 = 5x$ [10.1]
- $y^2 = 9 - x^2$ [10.2]
- $3x^2 + 4y^2 = 12$ [10.2]
- $9y^2 - 4x^2 = 36$ [10.3]
- $x^2 + y^2 + 2x - 3y = 8$ [10.2]
- $4x^2 + y^2 - 16x - 6y = 15$ [10.2]
- $x^2 - 8x + 6y = 0$ [10.1]
- $\frac{(x + 3)^2}{16} - \frac{(y - 1)^2}{25} = 1$ [10.3]
- Find an equation of the parabola with directrix $y = \frac{3}{2}$ and focus $(0, -\frac{3}{2})$. [10.1]
- Find the focus, the vertex, and the directrix of the parabola given by $y^2 = -12x$. [10.1]
- Find the vertex, the focus, and the directrix of the parabola given by $x^2 + 10x + 2y + 9 = 0$. [10.1]
- Find the center, the vertices, and the foci of the ellipse given by $16x^2 + 25y^2 - 64x + 50y - 311 = 0$. Then draw the graph. [10.2]
- Find an equation of the ellipse having vertices $(0, -4)$ and $(0, 4)$ with minor axis of length 6. [10.2]
- Find the center, the vertices, the foci, and the asymptotes of the hyperbola given by $x^2 - 2y^2 + 4x + y - \frac{1}{8} = 0$. [10.3]

20. **Spotlight.** A spotlight has a parabolic cross section that is 2 ft wide at the opening and 1.5 ft deep at the vertex. How far from the vertex is the focus? [10.1]

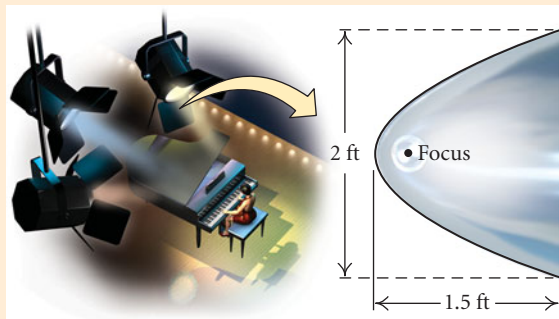

Solve. [10.4]

21. $x^2 - 16y = 0$,
 $x^2 - y^2 = 64$
22. $4x^2 + 4y^2 = 65$,
 $6x^2 - 4y^2 = 25$
23. $x^2 - y^2 = 33$,
 $x + y = 11$
24. $x^2 - 2x + 2y^2 = 8$,
 $2x + y = 6$
25. $x^2 - y = 3$,
 $2x - y = 3$
26. $x^2 + y^2 = 25$,
 $x^2 - y^2 = 7$
27. $x^2 - y^2 = 3$,
 $y = x^2 - 3$
28. $x^2 + y^2 = 18$,
 $2x + y = 3$
29. $x^2 + y^2 = 100$,
 $2x^2 - 3y^2 = -120$
30. $x^2 + 2y^2 = 12$,
 $xy = 4$
31. **Numerical Relationship.** The sum of two numbers is 11 and the sum of their squares is 65. Find the numbers. [10.4]
32. **Dimensions of a Rectangle.** A rectangle has a perimeter of 38 m and an area of 84 m^2 . What are the dimensions of the rectangle? [10.4]
33. **Numerical Relationship.** Find two positive integers whose sum is 12 and the sum of whose reciprocals is $\frac{3}{8}$. [10.4]
34. **Perimeter.** The perimeter of a square is 12 cm more than the perimeter of another square. The area of the first square exceeds the area of the other by 39 cm^2 . Find the perimeter of each square. [10.4]
35. **Radius of a Circle.** The sum of the areas of two circles is $130\pi \text{ ft}^2$. The difference of the areas is $112\pi \text{ ft}^2$. Find the radius of each circle. [10.4]

Graph the system of inequalities. Then find the coordinates of the points of intersection of the graphs of the related equations. [10.4]

36. $y \leq 4 - x^2$,
 $x - y \leq 2$
37. $x^2 + y^2 \leq 16$,
 $x + y < 4$
38. $y \geq x^2 - 1$,
 $y < 1$
39. $x^2 + y^2 \leq 9$,
 $x \leq -1$

Graph the equation. [10.5]

40. $5x^2 - 2xy + 5y^2 - 24 = 0$
41. $x^2 - 10xy + y^2 + 12 = 0$
42. $5x^2 + 6\sqrt{3}xy - y^2 = 16$
43. $x^2 + 2xy + y^2 - \sqrt{2}x + \sqrt{2}y = 0$

Graph the equation. State whether the directrix is vertical or horizontal, describe its location in relation to the pole, and find the vertex or vertices. [10.6]

44. $r = \frac{6}{3 - 3 \sin \theta}$
45. $r = \frac{8}{2 + 4 \cos \theta}$
46. $r = \frac{4}{2 - \cos \theta}$
47. $r = \frac{18}{9 + 6 \sin \theta}$
- 48.–51. Convert the equations in Exercises 44–47 to rectangular equations. [10.6]

Find a polar equation of the conic with a focus at the pole and the given eccentricity and directrix. [10.6]

52. $e = \frac{1}{2}$, $r = 2 \sec \theta$
53. $e = 3$, $r = -6 \csc \theta$
54. $e = 1$, $r = -4 \sec \theta$
55. $e = 2$, $r = 3 \csc \theta$

Graph the plane curve given by the set of parametric equations and the restrictions for the parameter. Then find the equivalent rectangular equation. [10.7]

56. $x = t$, $y = 2 + t$; $-3 \leq t \leq 3$
57. $x = \sqrt{t}$, $y = t - 1$; $0 \leq t \leq 9$
58. $x = 2 \cos t$, $y = 2 \sin t$; $0 \leq t \leq 2\pi$
59. $x = 3 \sin t$, $y = \cos t$; $0 \leq t \leq 2\pi$

Find two sets of parametric equations for the given rectangular equation. [10.7]

60. $y = 2x - 3$
61. $y = x^2 + 4$

62. **Projectile Motion.** A projectile is launched from the ground with an initial speed of 150 ft/sec at an angle of 45° with the horizontal. [10.7]
- Find parametric equations that give the position of the projectile at time t , in seconds.
 - Find the height of the projectile after 3 sec and after 6 sec.
 - Determine how long the projectile is in the air.
 - Determine the horizontal distance that the projectile travels.
 - Find the maximum height of the projectile.
63. The vertex of the parabola $y^2 - 4y - 12x - 8 = 0$ is which of the following? [10.1]
- $(1, -2)$
 - $(-1, 2)$
 - $(2, -1)$
 - $(-2, 1)$
64. Which of the following cannot be a number of solutions possible for a system of equations representing an ellipse and a straight line? [10.4]
- 0
 - 1
 - 2
 - 4
65. The graph of $x^2 + 4y^2 = 4$ is which of the following? [10.2], [10.3]

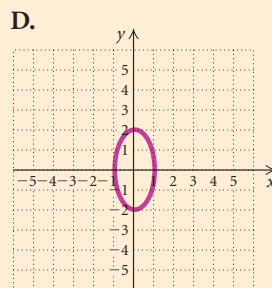
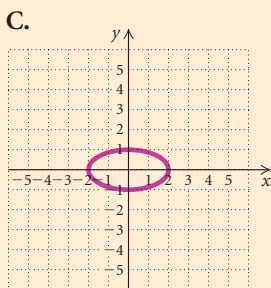
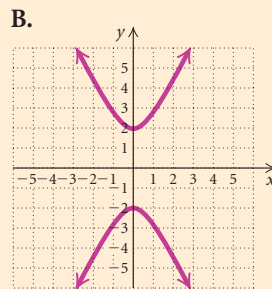
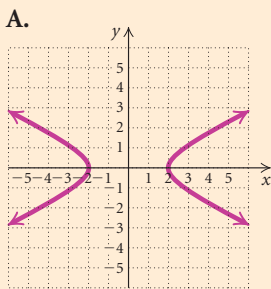

Synthesis

66. Find two numbers whose product is 4 and the sum of whose reciprocals is $\frac{65}{56}$. [10.4]

67. Find an equation of the circle that passes through the points $(10, 7)$, $(-6, 7)$, and $(-8, 1)$. [10.2], [10.4]
68. Find an equation of the ellipse containing the point $(-1/2, 3\sqrt{3}/2)$ and with vertices $(0, -3)$ and $(0, 3)$. [10.2]
69. **Navigation.** Two radio transmitters positioned 400 mi apart along the shore send simultaneous signals to a ship that is 250 mi offshore, sailing parallel to the shoreline.

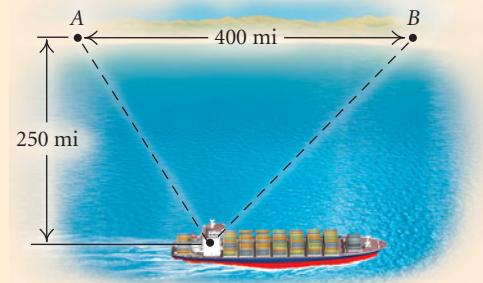

The signal from transmitter A reaches the ship 300 microseconds before the signal from transmitter B. The signals travel at a speed of 186,000 miles per second, or 0.186 mile per microsecond. Find the equation of the hyperbola with foci A and B on which the ship is located. (*Hint:* For any point on the hyperbola, the absolute value of the difference of its distances from the foci is $2a$.) [10.3]

Collaborative Discussion and Writing

70. Explain how the distance formula is used to find the standard equation of a parabola. [10.1]
71. Explain why function notation is not used in Section 10.2. [10.2]
72. Explain how the procedure you would follow for graphing an equation of the form $Ax^2 + Bxy + Cy^2 + Dx + Ey + F = 0$ when $B \neq 0$ differs from the procedure you would follow when $B = 0$. [10.5]
73. Consider the graphs of

$$r = \frac{e}{1 - e \sin \theta}$$

for $e = 0.2, 0.4, 0.6$, and 0.8 . Explain the effect of the value of e on the graph. [10.6]

Chapter 10 Test

In Exercises 1–4, match the equation with one of the graphs (a)–(d), which follow.

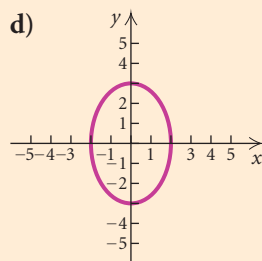
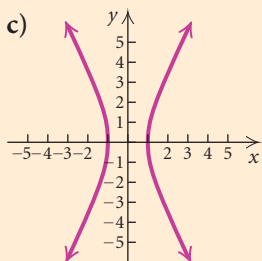
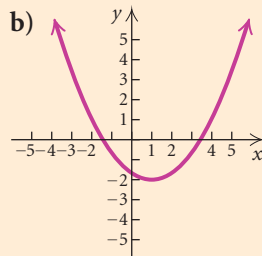
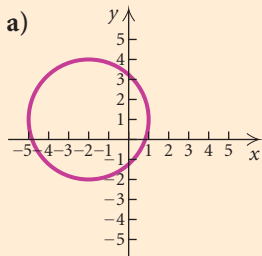

- $4x^2 - y^2 = 4$
- $x^2 - 2x - 3y = 5$
- $x^2 + 4x + y^2 - 2y - 4 = 0$
- $9x^2 + 4y^2 = 36$

Find the vertex, the focus, and the directrix of the parabola. Then draw the graph.

- $x^2 = 12y$
- $y^2 + 2y - 8x - 7 = 0$
- Find an equation of the parabola with focus $(0, 2)$ and directrix $y = -2$.
- Find the center and the radius of the circle given by $x^2 + y^2 + 2x - 6y - 15 = 0$. Then draw the graph.

Find the center, the vertices, and the foci of the ellipse. Then draw the graph.

- $9x^2 + 16y^2 = 144$
- $\frac{(x + 1)^2}{4} + \frac{(y - 2)^2}{9} = 1$

- Find an equation of the ellipse having vertices $(0, -5)$ and $(0, 5)$ and with minor axis of length 4.

Find the center, the vertices, the foci, and the asymptotes of the hyperbola. Then draw the graph.

- $4x^2 - y^2 = 4$
- $\frac{(y - 2)^2}{4} - \frac{(x + 1)^2}{9} = 1$

- Find the asymptotes of the hyperbola given by $2y^2 - x^2 = 18$.

- Satellite Dish.** A satellite dish has a parabolic cross section that is 18 in. wide at the opening and 6 in. deep at the vertex. How far from the vertex is the focus?

Solve.

- $2x^2 - 3y^2 = -10$,
 $x^2 + 2y^2 = 9$
- $x^2 + y^2 = 13$,
 $x + y = 1$
- $x + y = 5$,
 $xy = 6$
- Landscaping.** Leisurescape is planting a rectangular flower garden with a perimeter of 18 ft and a diagonal of $\sqrt{41}$ ft. Find the dimensions of the garden.
- Fencing.** It will take 210 ft of fencing to enclose a rectangular playground with an area of 2700 ft². Find the dimensions of the playground.
- Graph the system of inequalities. Then find the coordinates of the points of intersection of the graphs of the related equations.

$$y \geq x^2 - 4,$$

$$y < 2x - 1.$$

- Graph: $5x^2 - 8xy + 5y^2 = 9$.

23. Graph $r = \frac{2}{1 - \sin \theta}$. State whether the directrix is vertical or horizontal, describe its location in relation to the pole, and find the vertex or vertices.
24. Find a polar equation of the conic with a focus at the pole, eccentricity 2, and directrix $r = 3 \sec \theta$.
25. Graph the plane curve given by the parametric equations $x = \sqrt{t}$, $y = t + 2$; $0 \leq t \leq 16$.
26. Find a rectangular equation equivalent to $x = 3 \cos \theta$, $y = 3 \sin \theta$; $0 \leq \theta \leq 2\pi$.
27. Find two sets of parametric equations for the rectangular equation $y = x - 5$.
28. **Projectile Motion.** A projectile is launched from a height of 10 ft with an initial speed of 250 ft/sec at an angle of 30° with the horizontal.
- Find parametric equations that give the position of the projectile at time t , in seconds.
 - Find the height of the projectile after 1 sec and after 3 sec.
 - Determine how long the projectile is in the air.
 - Determine the horizontal distance that the projectile travels.
 - Find the maximum height of the projectile.

29. The graph of $(y - 1)^2 = 4(x + 1)$ is which of the following?

A.

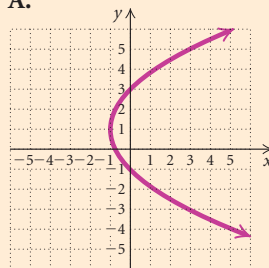

B.

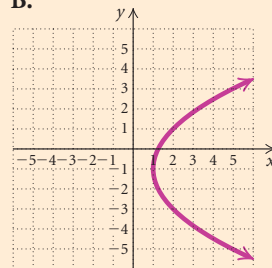

C.

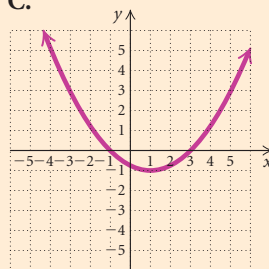

D.

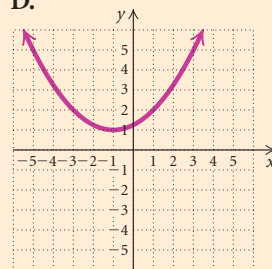

Synthesis

30. Find an equation of the circle for which the endpoints of a diameter are $(1, 1)$ and $(5, -3)$.

This page intentionally left blank

Sequences, Series, and Combinatorics

CHAPTER

11



Application

Large sporting events have a significant impact on the economy of the host city. Those attending the 2010 Super Bowl in Miami poured \$333 million into the economy of south Florida (*Source: Sport Management Research Institute*). Assume that 60% of that amount is spent again in the area, and then 60% of that amount is spent again, and so on. This is known as the *economic multiplier effect*. Find the total effect on the economy.

This problem appears as Example 10 in Section 11.3.

- 11.1 Sequences and Series
- 11.2 Arithmetic Sequences and Series
- 11.3 Geometric Sequences and Series

Visualizing the Graph

- 11.4 Mathematical Induction

Mid-Chapter Mixed Review

- 11.5 Combinatorics: Permutations
- 11.6 Combinatorics: Combinations
- 11.7 The Binomial Theorem
- 11.8 Probability

Study Guide

Review Exercises

Chapter Test

Sequences and Series

11.1

- ▶ Find terms of sequences given the n th term.
- ▶ Look for a pattern in a sequence and try to determine a general term.
- ▶ Convert between sigma notation and other notation for a series.
- ▶ Construct the terms of a recursively defined sequence.

In this section, we discuss sets or lists of numbers, considered in order, and their sums.

▶ Sequences

Suppose that \$1000 is invested at 6%, compounded annually. The amounts to which the account will grow after 1 yr, 2 yr, 3 yr, 4 yr, and so on, form the following sequence of numbers:

$$\begin{array}{cccc} (1) & (2) & (3) & (4) \\ \downarrow & \downarrow & \downarrow & \downarrow \\ \$1060.00, & \$1123.60, & \$1191.02, & \$1262.48, \dots \end{array}$$

We can think of this as a function that pairs 1 with \$1060.00, 2 with \$1123.60, 3 with \$1191.02, and so on. A **sequence** is thus a *function*, where the domain is a set of consecutive positive integers beginning with 1.

If we continue to compute the amounts of money in the account forever, we obtain an **infinite sequence** with function values

$$\$1060.00, \$1123.60, \$1191.02, \$1262.48, \$1338.23, \$1418.52, \dots$$

The dots “...” at the end indicate that the sequence goes on without stopping. If we stop after a certain number of years, we obtain a **finite sequence**:

$$\$1060.00, \$1123.60, \$1191.02, \$1262.48.$$

Sequences

An **infinite sequence** is a function having for its domain the set of positive integers, $\{1, 2, 3, 4, 5, \dots\}$.

A **finite sequence** is a function having for its domain a set of positive integers, $\{1, 2, 3, 4, 5, \dots, n\}$, for some positive integer n .

Consider the sequence given by the formula

$$a(n) = 2^n, \quad \text{or} \quad a_n = 2^n.$$

Some of the function values, also known as the **terms** of the sequence, follow:

$$\begin{aligned}a_1 &= 2^1 = 2, \\a_2 &= 2^2 = 4, \\a_3 &= 2^3 = 8, \\a_4 &= 2^4 = 16, \\a_5 &= 2^5 = 32.\end{aligned}$$

The first term of the sequence is denoted as a_1 , the fifth term as a_5 , and the n th term, or **general term**, as a_n . This sequence can also be denoted as

$$2, 4, 8, \dots, \text{ or as } 2, 4, 8, \dots, 2^n, \dots$$

EXAMPLE 1 Find the first 4 terms and the 23rd term of the sequence whose general term is given by $a_n = (-1)^n n^2$.

Solution We have $a_n = (-1)^n n^2$, so

$$\begin{aligned}a_1 &= (-1)^1 \cdot 1^2 = -1, \\a_2 &= (-1)^2 \cdot 2^2 = 4, \\a_3 &= (-1)^3 \cdot 3^2 = -9, \\a_4 &= (-1)^4 \cdot 4^2 = 16, \\a_{23} &= (-1)^{23} \cdot 23^2 = -529.\end{aligned}$$

 **Now Try Exercise 1.**

Note in Example 1 that the power $(-1)^n$ causes the signs of the terms to alternate between positive and negative, depending on whether n is even or odd. This kind of sequence is called an **alternating sequence**.

TECHNOLOGY CONNECTION

X	Y1	
1	-1	
2	4	
3	-9	
4	16	
23	-529	

X =

We can use a graphing calculator to find the desired terms of the sequence in Example 1. We enter $y_1 = (-1)^x x^2$. We then set up a table in ASK mode and enter 1, 2, 3, 4, and 23 as values for x .

We can also use the SEQ feature to find the terms of a sequence. Suppose, for example, that we want to find the first 5 terms of the sequence whose general term is given by $a_n = n/(n + 1)$. We select SEQ from the LIST OPS menu and enter the general term, the variable, and the numbers of the first and last terms desired. The calculator will write the terms horizontally as a list. The list can also be written in fraction notation.

```
seq(X/(X+1),X,1,5)▶Frac
{1/2 2/3 3/4 4/...
```

```
seq(X/(X+1),X,1,5)▶Frac
.../3 3/4 4/5 5/6}
```

We use the \square key to view the two items that do not initially appear on the screen. The first 5 terms of the sequence are $1/2$, $2/3$, $3/4$, $4/5$, and $5/6$.

We can graph a sequence just as we graph other functions. Consider the function given by $f(x) = x + 1$ and the sequence whose general term is given by $a_n = n + 1$. The graph of $f(x) = x + 1$ is shown on the left below. Since the domain of a sequence is a set of positive integers, the graph of a sequence is a set of points that are not connected. Thus if we use only positive integers for inputs of $f(x) = x + 1$, we have the graph of the sequence $a_n = n + 1$, as shown on the right below.

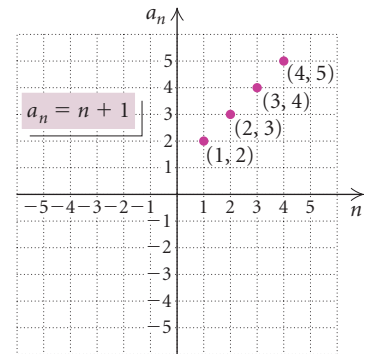
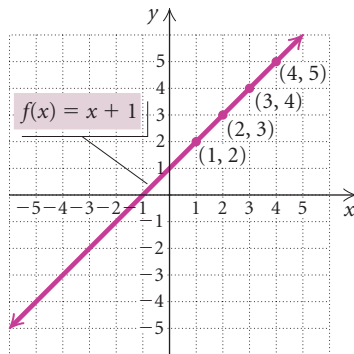

► Finding the General Term

When only the first few terms of a sequence are known, we do not know for sure what the general term is, but we might be able to make a prediction by looking for a pattern.

EXAMPLE 2 For each of the following sequences, predict the general term.

- a) $1, \sqrt{2}, \sqrt{3}, 2, \dots$ b) $-1, 3, -9, 27, -81, \dots$
 c) $2, 4, 8, \dots$

Solution

- a) These are square roots of consecutive integers, so the general term might be \sqrt{n} .
 b) These are powers of 3 with alternating signs, so the general term might be $(-1)^n 3^{n-1}$.
 c) If we see the pattern of powers of 2, we will see 16 as the next term and guess 2^n for the general term. Then the sequence could be written with more terms as

$$2, 4, 8, 16, 32, 64, 128, \dots$$

If we see that we can get the second term by adding 2, the third term by adding 4, and the next term by adding 6, and so on, we will see 14 as the next term. A general term for the sequence is $n^2 - n + 2$, and the sequence can be written with more terms as

$$2, 4, 8, 14, 22, 32, 44, 58, \dots$$

➔ Now Try Exercise 19.

Example 2(c) illustrates that, in fact, you can never be certain about the general term when only a few terms are given. The fewer the number of given terms, the greater the uncertainty.

► Sums and Series

Series

Given the infinite sequence

$$a_1, a_2, a_3, a_4, \dots, a_n, \dots,$$

the sum of the terms

$$a_1 + a_2 + a_3 + \dots + a_n + \dots$$

is called an **infinite series**. A **partial sum** is the sum of the first n terms:

$$a_1 + a_2 + a_3 + \dots + a_n.$$

A partial sum is also called a **finite series**, or **n th partial sum**, and is denoted S_n .

EXAMPLE 3 For the sequence $-2, 4, -6, 8, -10, 12, -14, \dots$, find each of the following.

a) S_1

b) S_4

c) S_5

Solution

a) $S_1 = -2$

b) $S_4 = -2 + 4 + (-6) + 8 = 4$

c) $S_5 = -2 + 4 + (-6) + 8 + (-10) = -6$

➔ Now Try Exercise 29.

TECHNOLOGY CONNECTION

We can use a graphing calculator to find partial sums of a sequence when a formula for the general term is known. Suppose, for example, that we want to find S_1, S_2, S_3 , and S_4 for the sequence whose general term is given by $a_n = n^2 - 3$. We can use the CUMSUM feature from the LIST OPS menu. The calculator will write the partial sums as a list. (Note that the calculator can be set in either FUNCTION mode or SEQUENCE mode. Here we show SEQUENCE mode.)

```
cumSum(seq(n^2-3,
n,1,4))
      {-2 -1 5 18}
```

We have $S_1 = -2, S_2 = -1, S_3 = 5$, and $S_4 = 18$.

► Sigma Notation

The Greek letter Σ (sigma) can be used to denote a sum when the general term of a sequence is a formula. For example, the sum of the first four terms of the sequence $3, 5, 7, 9, \dots, 2k + 1, \dots$ can be named as follows, using what is called **sigma notation**, or **summation notation**:

$$\sum_{k=1}^4 (2k + 1).$$

This is read “the sum as k goes from 1 to 4 of $2k + 1$.” The letter k is called the **index of summation**. The index of summation might start at a number other than 1, and letters other than k can be used.

EXAMPLE 4 Find and evaluate each of the following sums.

$$\text{a) } \sum_{k=1}^5 k^3 \qquad \text{b) } \sum_{k=0}^4 (-1)^k 5^k \qquad \text{c) } \sum_{i=8}^{11} \left(2 + \frac{1}{i}\right)$$

Solution

a) We replace k with 1, 2, 3, 4, and 5. Then we add the results.

$$\begin{aligned} \sum_{k=1}^5 k^3 &= 1^3 + 2^3 + 3^3 + 4^3 + 5^3 \\ &= 1 + 8 + 27 + 64 + 125 \\ &= 225 \end{aligned}$$

$$\begin{aligned} \text{b) } \sum_{k=0}^4 (-1)^k 5^k &= (-1)^0 5^0 + (-1)^1 5^1 + (-1)^2 5^2 + (-1)^3 5^3 + (-1)^4 5^4 \\ &= 1 - 5 + 25 - 125 + 625 = 521 \end{aligned}$$

$$\begin{aligned} \text{c) } \sum_{i=8}^{11} \left(2 + \frac{1}{i}\right) &= \left(2 + \frac{1}{8}\right) + \left(2 + \frac{1}{9}\right) + \left(2 + \frac{1}{10}\right) + \left(2 + \frac{1}{11}\right) \\ &= 8 \frac{1691}{3960} \end{aligned}$$

➔ Now Try Exercise 33.

TECHNOLOGY CONNECTION

We can combine the SUM and SEQ features on a graphing calculator to add the terms of a sequence. We find the sum in Example 4(a) as shown below.

```
sum(seq(n^3,n,1,5))
```

225

EXAMPLE 5 Write sigma notation for each sum.

a) $1 + 2 + 4 + 8 + 16 + 32 + 64$

b) $-2 + 4 - 6 + 8 - 10$

c) $x + \frac{x^2}{2} + \frac{x^3}{3} + \frac{x^4}{4} + \dots$

Solution

a) $1 + 2 + 4 + 8 + 16 + 32 + 64$

This is the sum of powers of 2, beginning with 2^0 , or 1, and ending with 2^6 , or 64. Sigma notation is $\sum_{k=0}^6 2^k$.

b) $-2 + 4 - 6 + 8 - 10$

Disregarding the alternating signs, we see that this is the sum of the first 5 even integers. Note that $2k$ is a formula for the k th positive even integer, and $(-1)^k = -1$ when k is odd and $(-1)^k = 1$ when k is even. Thus the general term is $(-1)^k(2k)$. The sum begins with $k = 1$ and ends with $k = 5$, so sigma notation is $\sum_{k=1}^5 (-1)^k(2k)$.

c) $x + \frac{x^2}{2} + \frac{x^3}{3} + \frac{x^4}{4} + \dots$

The general term is x^k/k , beginning with $k = 1$. This is also an infinite series. We use the symbol ∞ for infinity and write the series using sigma notation: $\sum_{k=1}^{\infty} (x^k/k)$.

 **Now Try Exercise 51.**

► Recursive Definitions

A sequence may be defined **recursively** or by using a **recursion formula**. Such a definition lists the first term, or the first few terms, and then describes how to determine the remaining terms from the given terms.

EXAMPLE 6 Find the first 5 terms of the sequence defined by

$$a_1 = 5, \quad a_{n+1} = 2a_n - 3, \quad \text{for } n \geq 1.$$

Solution We have

$$\begin{aligned} a_1 &= 5, \\ a_2 &= 2a_1 - 3 = 2 \cdot 5 - 3 = 7, \\ a_3 &= 2a_2 - 3 = 2 \cdot 7 - 3 = 11, \\ a_4 &= 2a_3 - 3 = 2 \cdot 11 - 3 = 19, \\ a_5 &= 2a_4 - 3 = 2 \cdot 19 - 3 = 35. \end{aligned}$$

 **Now Try Exercise 61.**

TECHNOLOGY CONNECTION

Many graphing calculators have the capability to work with recursively defined sequences when they are set in SEQUENCE mode. In Example 6, for instance, the function could be entered as $u(n) = 2 * u(n - 1) - 3$ with $u(nMin) = 5$. We can read the terms of the sequence from a table.

```
Plot1 Plot2 Plot3
nMin=1
\u(n)=2*u(n-1)-3

u(nMin)=5
v(n)=
v(nMin)=
w(n)=
```

n	$u(n)$
1	5
2	7
3	11
4	19
5	35
6	67
7	131

$n = 1$

11.1

Exercise Set

In each of the following, the n th term of a sequence is given. Find the first 4 terms, a_{10} , and a_{15} .

- $a_n = 4n - 1$
- $a_n = (n - 1)(n - 2)(n - 3)$
- $a_n = \frac{n}{n - 1}, n \geq 2$
- $a_n = n^2 - 1, n \geq 3$
- $a_n = \frac{n^2 - 1}{n^2 + 1}$
- $a_n = \left(-\frac{1}{2}\right)^{n-1}$
- $a_n = (-1)^n n^2$
- $a_n = (-1)^{n-1}(3n - 5)$
- $a_n = 5 + \frac{(-2)^{n+1}}{2^n}$
- $a_n = \frac{2n - 1}{n^2 + 2n}$

Find the indicated term of the given sequence.

- $a_n = 5n - 6; a_8$
- $a_n = (3n - 4)(2n + 5); a_7$
- $a_n = (2n + 3)^2; a_6$
- $a_n = (-1)^{n-1}(4.6n - 18.3); a_{12}$
- $a_n = 5n^2(4n - 100); a_{11}$
- $a_n = \left(1 + \frac{1}{n}\right)^2; a_{80}$
- $a_n = \ln e^n; a_{67}$
- $a_n = 2 - \frac{1000}{n}; a_{100}$

Predict the general term, or n th term, a_n , of the sequence. Answers may vary.

- 2, 4, 6, 8, 10, ...
- 3, 9, 27, 81, 243, ...
- 2, 6, -18, 54, ...

- 2, 3, 8, 13, 18, ...
- $\frac{2}{3}, \frac{3}{4}, \frac{4}{5}, \frac{5}{6}, \frac{6}{7}, \dots$
- $\sqrt{2}, 2, \sqrt{6}, 2\sqrt{2}, \sqrt{10}, \dots$
- $1 \cdot 2, 2 \cdot 3, 3 \cdot 4, 4 \cdot 5, \dots$
- 1, -4, -7, -10, -13, ...
- 0, log 10, log 100, log 1000, ...
- $\ln e^2, \ln e^3, \ln e^4, \ln e^5, \dots$

Find the indicated partial sums for the sequence.

- 1, 2, 3, 4, 5, 6, 7, ...; S_3 and S_7
- 1, -3, 5, -7, 9, -11, ...; S_2 and S_5
- 2, 4, 6, 8, ...; S_4 and S_5
- $1, \frac{1}{4}, \frac{1}{9}, \frac{1}{16}, \frac{1}{25}, \dots$; S_1 and S_5

Find and evaluate the sum.

- $\sum_{k=1}^5 \frac{1}{2k}$
- $\sum_{i=1}^6 \frac{1}{2i + 1}$
- $\sum_{i=0}^6 2^i$
- $\sum_{k=4}^7 \sqrt{2k - 1}$
- $\sum_{k=7}^{10} \ln k$
- $\sum_{k=1}^4 \pi k$
- $\sum_{k=1}^8 \frac{k}{k + 1}$
- $\sum_{i=1}^5 \frac{i - 1}{i + 3}$
- $\sum_{i=1}^5 (-1)^i$
- $\sum_{k=0}^5 (-1)^{k+1} k^{k+1}$
- $\sum_{k=1}^8 (-1)^{k+1} 3k$
- $\sum_{k=0}^7 (-1)^k 4^{k+1}$
- $\sum_{k=0}^6 \frac{2}{k^2 + 1}$
- $\sum_{i=1}^{10} i(i + 1)$
- $\sum_{k=0}^5 (k^2 - 2k + 3)$
- $\sum_{k=1}^{10} \frac{1}{k(k + 1)}$
- $\sum_{i=0}^{10} \frac{2^i}{2^i + 1}$
- $\sum_{k=0}^3 (-2)^{2k}$

Write sigma notation. Answers may vary.

51. $5 + 10 + 15 + 20 + 25 + \cdots$

52. $7 + 14 + 21 + 28 + 35 + \cdots$

53. $2 - 4 + 8 - 16 + 32 - 64$

54. $3 + 6 + 9 + 12 + 15$

55. $-\frac{1}{2} + \frac{2}{3} - \frac{3}{4} + \frac{4}{5} - \frac{5}{6} + \frac{6}{7}$

56. $\frac{1}{1^2} + \frac{1}{2^2} + \frac{1}{3^2} + \frac{1}{4^2} + \frac{1}{5^2}$

57. $4 - 9 + 16 - 25 + \cdots + (-1)^n n^2$

58. $9 - 16 + 25 + \cdots + (-1)^{n+1} n^2$

59. $\frac{1}{1 \cdot 2} + \frac{1}{2 \cdot 3} + \frac{1}{3 \cdot 4} + \frac{1}{4 \cdot 5} + \cdots$

60. $\frac{1}{1 \cdot 2^2} + \frac{1}{2 \cdot 3^2} + \frac{1}{3 \cdot 4^2} + \frac{1}{4 \cdot 5^2} + \cdots$

Find the first 4 terms of the recursively defined sequence.

61. $a_1 = 4, a_{n+1} = 1 + \frac{1}{a_n}$

62. $a_1 = 256, a_{n+1} = \sqrt{a_n}$

63. $a_1 = 6561, a_{n+1} = (-1)^n \sqrt{a_n}$

64. $a_1 = e^Q, a_{n+1} = \ln a_n$

65. $a_1 = 2, a_2 = 3, a_{n+1} = a_n + a_{n-1}$

66. $a_1 = -10, a_2 = 8, a_{n+1} = a_n - a_{n-1}$

67. **Compound Interest.** Suppose that \$1000 is invested at 6.2%, compounded annually. The value of the investment after n years is given by the sequence model

$$a_n = \$1000(1.062)^n, \quad n = 1, 2, 3, \dots$$

a) Find the first 10 terms of the sequence.

b) Find the value of the investment after 20 yr.

68. **Salvage Value.** The value of an office machine is \$5200. Its salvage value each year is 75% of its value the year before. Give a sequence that lists the salvage value of the machine for each year of a 10-yr period.

69. **Bacteria Growth.** Suppose a single cell of bacteria divides into two every 15 min. Suppose that the same rate of division is maintained for 4 hr.

Give a sequence that lists the number of cells after successive 15-min periods.



70. **Wage Sequence.** Torrey is paid \$8.30 per hour for working at Red Freight Limited. Each year he receives a \$0.30 hourly raise. Give a sequence that lists Torrey's hourly wage over a 10-yr period.

71. **Fibonacci Sequence: Rabbit Population Growth.** One of the most famous recursively defined sequences is the **Fibonacci sequence**. In 1202, the Italian mathematician Leonardo da Pisa, also called Fibonacci, proposed the following model for rabbit population growth. Suppose that every month each mature pair of rabbits in the population produces a new pair that begins reproducing after two months, and also suppose that no rabbits die. Beginning with one pair of newborn rabbits, the population can be modeled by the following recursively defined sequence:

$$a_1 = 1, \quad a_2 = 1, \quad a_n = a_{n-1} + a_{n-2}, \quad \text{for } n \geq 3,$$

where a_n is the total number of pairs of rabbits in month n . Find the first 7 terms of the Fibonacci sequence.

Skill Maintenance

Solve.

72. $3x - 2y = 3,$
 $2x + 3y = -11$

73. **Tourism.** A total of 18.1 million international visitors traveled to New York City in 2008 and 2009. The number of international visitors in 2009 was 0.9 million fewer than in 2008. (Source: NYC & Co.) Find the number of international visitors to New York City in each year.

Find the center and the radius of the circle with the given equation.

74. $x^2 + y^2 - 6x + 4y = 3$

75. $x^2 + y^2 + 5x - 8y = 2$

Synthesis

Find the first 5 terms of the sequence, and then find S_5 .

76. $a_n = \frac{1}{2^n} \log 1000^n$

77. $a_n = i^n, i = \sqrt{-1}$

78. $a_n = \ln(1 \cdot 2 \cdot 3 \cdots n)$

For each sequence, find a formula for S_n .

79. $a_n = \ln n$

80. $a_n = \frac{1}{n} - \frac{1}{n+1}$

Arithmetic Sequences and Series

11.2

- ▶ For any arithmetic sequence, find the n th term when n is given and n when the n th term is given; and given two terms, find the common difference and construct the sequence.
- ▶ Find the sum of the first n terms of an arithmetic sequence.

A sequence in which each term after the first is found by adding the same number to the preceding term is an **arithmetic sequence**.

▶ Arithmetic Sequences

The sequence 2, 5, 8, 11, 14, 17, ... is arithmetic because adding 3 to any term produces the next term. In other words, the difference between any term and the preceding one is 3. Arithmetic sequences are also called *arithmetic progressions*.

Arithmetic Sequence

A sequence is **arithmetic** if there exists a number d , called the **common difference**, such that $a_{n+1} = a_n + d$ for any integer $n \geq 1$.

EXAMPLE 1 For each of the following arithmetic sequences, identify the first term, a_1 , and the common difference, d .

- a) 4, 9, 14, 19, 24, ...
- b) 34, 27, 20, 13, 6, -1, -8, ...
- c) $2, 2\frac{1}{2}, 3, 3\frac{1}{2}, 4, 4\frac{1}{2}, \dots$

STUDY TIP

The best way to prepare for a final exam is to do so over a period of at least two weeks. First review each chapter, studying the formulas, theorems, properties, and procedures in the sections and in the Study Guide in the Chapter Summary and Review. Then take each of the Chapter Tests again. If you miss any questions, spend extra time reviewing the corresponding topics. Also consider participating in a study group or attending a tutoring or review session.

Solution The first term, a_1 , is the first term listed. To find the common difference, d , we choose any term beyond the first and subtract the preceding term from it.

SEQUENCE	FIRST TERM, a_1	COMMON DIFFERENCE, d
a) 4, 9, 14, 19, 24, ...	4	5 ($9 - 4 = 5$)
b) 34, 27, 20, 13, 6, -1, -8, ...	34	-7 ($27 - 34 = -7$)
c) $2, 2\frac{1}{2}, 3, 3\frac{1}{2}, 4, 4\frac{1}{2}, \dots$	2	$\frac{1}{2}$ ($2\frac{1}{2} - 2 = \frac{1}{2}$)

We obtained the common difference by subtracting a_1 from a_2 . Had we subtracted a_2 from a_3 or a_3 from a_4 , we would have obtained the same values for d . Thus we can check by adding d to each term in a sequence to see if we progress correctly to the next term.

Check:

$$\text{a) } 4 + 5 = 9, \quad 9 + 5 = 14, \quad 14 + 5 = 19, \quad 19 + 5 = 24$$

$$\text{b) } 34 + (-7) = 27, \quad 27 + (-7) = 20, \quad 20 + (-7) = 13, \\ 13 + (-7) = 6, \quad 6 + (-7) = -1, \quad -1 + (-7) = -8$$

$$\text{c) } 2 + \frac{1}{2} = 2\frac{1}{2}, \quad 2\frac{1}{2} + \frac{1}{2} = 3, \quad 3 + \frac{1}{2} = 3\frac{1}{2}, \quad 3\frac{1}{2} + \frac{1}{2} = 4, \\ 4 + \frac{1}{2} = 4\frac{1}{2}$$

 **Now Try Exercise 1.**

To find a formula for the general, or n th, term of any arithmetic sequence, we denote the common difference by d , write out the first few terms, and look for a pattern:

$$a_1,$$

$$a_2 = a_1 + d,$$

$$a_3 = a_2 + d = (a_1 + d) + d = a_1 + 2d, \quad \text{Substituting for } a_2$$

$$a_4 = a_3 + d = (a_1 + 2d) + d = a_1 + 3d. \quad \text{Substituting for } a_3$$

 **Note that the coefficient of d in each case is 1 less than the subscript.**

Generalizing, we obtain the following formula.

n th Term of an Arithmetic Sequence

The n th term of an arithmetic sequence is given by

$$a_n = a_1 + (n - 1)d, \text{ for any integer } n \geq 1.$$

EXAMPLE 2 Find the 14th term of the arithmetic sequence 4, 7, 10, 13, . . .

Solution We first note that $a_1 = 4$, $d = 7 - 4$, or 3, and $n = 14$. Then using the formula for the n th term, we obtain

$$\begin{aligned} a_n &= a_1 + (n - 1)d \\ a_{14} &= 4 + (14 - 1) \cdot 3 && \text{Substituting} \\ &= 4 + 13 \cdot 3 = 4 + 39 \\ &= 43. \end{aligned}$$

The 14th term is 43.

 **Now Try Exercise 9.**

EXAMPLE 3 In the sequence of Example 2, which term is 301? That is, find n if $a_n = 301$.

Solution We substitute 301 for a_n , 4 for a_1 , and 3 for d in the formula for the n th term and solve for n :

$$\begin{aligned} a_n &= a_1 + (n - 1)d \\ 301 &= 4 + (n - 1) \cdot 3 && \text{Substituting} \\ 301 &= 4 + 3n - 3 \\ 301 &= 3n + 1 && \left. \begin{array}{l} \\ \\ \\ \end{array} \right\} \text{Solving for } n \\ 300 &= 3n \\ 100 &= n. \end{aligned}$$

The term 301 is the 100th term of the sequence.

 **Now Try Exercise 15.**

Given two terms and their places in an arithmetic sequence, we can construct the sequence.

EXAMPLE 4 The 3rd term of an arithmetic sequence is 8, and the 16th term is 47. Find a_1 and d and construct the sequence.

Solution We know that $a_3 = 8$ and $a_{16} = 47$. Thus we would have to add d 13 times to get from 8 to 47. That is,

$$8 + 13d = 47. \quad a_3 \text{ and } a_{16} \text{ are } 16 - 3, \text{ or } 13, \text{ terms apart.}$$

Solving $8 + 13d = 47$, we obtain

$$\begin{aligned} 13d &= 39 \\ d &= 3. \end{aligned}$$

Since $a_3 = 8$, we subtract d twice to get a_1 . Thus,

$$a_1 = 8 - 2 \cdot 3 = 2. \quad a_1 \text{ and } a_3 \text{ are } 3 - 1, \text{ or } 2, \text{ terms apart.}$$

The sequence is 2, 5, 8, 11, . . . Note that we could also subtract d 15 times from a_{16} in order to find a_1 .

 **Now Try Exercise 23.**

In general, d should be subtracted $n - 1$ times from a_n in order to find a_1 .

► Sum of the First n Terms of an Arithmetic Sequence

Consider the arithmetic sequence

$$3, 5, 7, 9, \dots$$

When we add the first 4 terms of the sequence, we get S_4 , which is

$$3 + 5 + 7 + 9, \text{ or } 24.$$

This sum is called an **arithmetic series**. To find a formula for the sum of the first n terms, S_n , of an arithmetic sequence, we first denote an arithmetic sequence, as follows:

This term is two terms back from the last. If you add d to this term, the result is the next-to-last term, $a_n - d$.

$$a_1, (a_1 + d), (a_1 + 2d), \dots, \underbrace{(a_n - 2d)}, \underbrace{(a_n - d)}, a_n.$$

This is the next-to-last term. If you add d to this term, the result is a_n .

Then S_n is given by

$$S_n = a_1 + (a_1 + d) + (a_1 + 2d) + \dots + (a_n - 2d) + (a_n - d) + a_n. \quad (1)$$

Reversing the order of the addition gives us

$$S_n = a_n + (a_n - d) + (a_n - 2d) + \dots + (a_1 + 2d) + (a_1 + d) + a_1. \quad (2)$$

If we add corresponding terms of each side of equations (1) and (2), we get

$$2S_n = [a_1 + a_n] + [(a_1 + d) + (a_n - d)] + [(a_1 + 2d) + (a_n - 2d)] + \dots + [(a_n - 2d) + (a_1 + 2d)] + [(a_n - d) + (a_1 + d)] + [a_n + a_1].$$

In the expression for $2S_n$, there are n expressions in square brackets. Each of these expressions is equivalent to $a_1 + a_n$. Thus the expression for $2S_n$ can be written in simplified form as

$$2S_n = [a_1 + a_n] + [a_1 + a_n] + [a_1 + a_n] + \dots + [a_n + a_1] + [a_n + a_1].$$

Since $a_1 + a_n$ is being added n times, it follows that

$$2S_n = n(a_1 + a_n),$$

from which we get the following formula.

Sum of the First n Terms

The sum of the first n terms of an arithmetic sequence is given by

$$S_n = \frac{n}{2}(a_1 + a_n).$$

EXAMPLE 5 Find the sum of the first 100 natural numbers.

Solution The sum is

$$1 + 2 + 3 + \cdots + 99 + 100.$$

This is the sum of the first 100 terms of the arithmetic sequence for which

$$a_1 = 1, \quad a_n = 100, \quad \text{and} \quad n = 100.$$

Thus substituting into the formula

$$S_n = \frac{n}{2}(a_1 + a_n),$$

we get

$$S_{100} = \frac{100}{2}(1 + 100) = 50(101) = 5050.$$

The sum of the first 100 natural numbers is 5050.

 **Now Try Exercise 27.**

EXAMPLE 6 Find the sum of the first 15 terms of the arithmetic sequence 4, 7, 10, 13,

Solution Note that $a_1 = 4$, $d = 3$, and $n = 15$. Before using the formula

$$S_n = \frac{n}{2}(a_1 + a_n),$$

we find the last term, a_{15} :

$$\begin{aligned} a_{15} &= 4 + (15 - 1)3 && \text{Substituting into the formula } a_n = a_1 + (n - 1)d \\ &= 4 + 14 \cdot 3 = 46. \end{aligned}$$

Thus,

$$S_{15} = \frac{15}{2}(4 + 46) = \frac{15}{2}(50) = 375.$$

The sum of the first 15 terms is 375.

 **Now Try Exercise 25.**

EXAMPLE 7 Find the sum: $\sum_{k=1}^{130} (4k + 5)$.

Solution It is helpful to first write out a few terms:

$$9 + 13 + 17 + \cdots.$$

It appears that this is an arithmetic series coming from an arithmetic sequence with $a_1 = 9$, $d = 4$, and $n = 130$. Before using the formula

$$S_n = \frac{n}{2}(a_1 + a_n),$$

we find the last term, a_{130} :

$$\begin{aligned} a_{130} &= 4 \cdot 130 + 5 && \text{The } k\text{th term is } 4k + 5. \\ &= 520 + 5 \\ &= 525. \end{aligned}$$

Thus,

$$\begin{aligned} S_{130} &= \frac{130}{2}(9 + 525) && \text{Substituting into } S_n = \frac{n}{2}(a_1 + a_n) \\ &= 34,710. \end{aligned}$$

 **Now Try Exercise 33.**

► Applications

The translation of some applications and problem-solving situations may involve arithmetic sequences or series. We consider some examples.

EXAMPLE 8 *Hourly Wages.* Gloria accepts a job, starting with an hourly wage of \$14.25, and is promised a raise of 15¢ per hour every 2 months for 5 yr. At the end of 5 yr, what will Gloria's hourly wage be?

Solution It helps to first write down the hourly wage for several 2-month time periods:

Beginning: \$14.25,
 After 2 months: \$14.40,
 After 4 months: \$14.55,
 and so on.

What appears is a sequence of numbers: 14.25, 14.40, 14.55, This sequence is arithmetic, because adding 0.15 each time gives us the next term.

We want to find the last term of an arithmetic sequence, so we use the formula $a_n = a_1 + (n - 1)d$. We know that $a_1 = 14.25$ and $d = 0.15$, but what is n ? That is, how many terms are in the sequence? Each year there are $12/2$, or 6 raises, since Gloria gets a raise every 2 months. There are 5 yr, so the total number of raises will be $5 \cdot 6$, or 30. Thus there will be 31 terms: the original wage and 30 increased rates.

Substituting in the formula $a_n = a_1 + (n - 1)d$ gives us

$$\begin{aligned} a_{31} &= 14.25 + (31 - 1) \cdot 0.15 \\ &= 18.75. \end{aligned}$$

Thus, at the end of 5 yr, Gloria's hourly wage will be \$18.75.

 **Now Try Exercise 43.**

The calculations in Example 8 could be done in a number of ways. There is often a variety of ways in which a problem can be solved. In this chapter, we concentrate on the use of sequences and series and their related formulas.

EXAMPLE 9 *Total in a Stack.* A stack of telephone poles has 30 poles in the bottom row. There are 29 poles in the second row, 28 in the next row, and so on. How many poles are in the stack if there are 5 poles in the top row?

Solution A picture will help in this case. The following figure shows the ends of the poles and the way in which they stack.

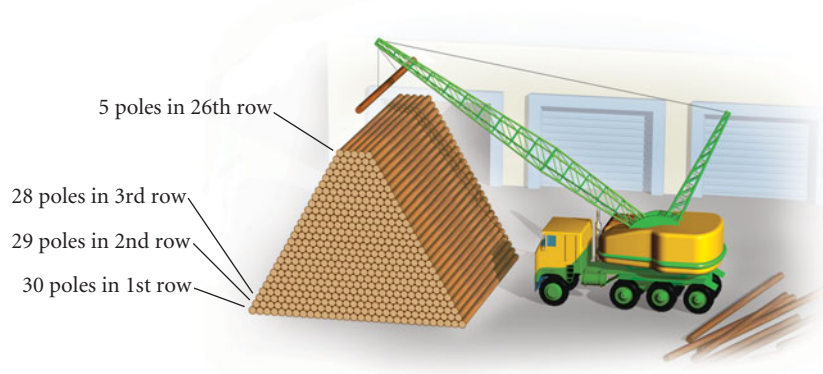

Since the number of poles goes from 30 in a row up to 5 in the top row, there must be 26 rows. We want the sum

$$30 + 29 + 28 + \cdots + 5.$$

Thus we have an arithmetic series. We use the formula

$$S_n = \frac{n}{2}(a_1 + a_n),$$

with $n = 26$, $a_1 = 30$, and $a_{26} = 5$.

Substituting, we get

$$S_{26} = \frac{26}{2}(30 + 5) = 455.$$

There are 455 poles in the stack.

 **Now Try Exercise 39.**

11.2 Exercise Set

Find the first term and the common difference.

- 3, 8, 13, 18, ...
- \$1.08, \$1.16, \$1.24, \$1.32, ...
- 9, 5, 1, -3, ...
- 8, -5, -2, 1, 4, ...
- $\frac{3}{2}, \frac{9}{4}, 3, \frac{15}{4}, \dots$
- $\frac{3}{5}, \frac{1}{10}, -\frac{2}{5}, \dots$
- \$316, \$313, \$310, \$307, ...
- Find the 11th term of the arithmetic sequence 0.07, 0.12, 0.17, ...
- Find the 12th term of the arithmetic sequence 2, 6, 10, ...
- Find the 17th term of the arithmetic sequence 7, 4, 1, ...
- Find the 14th term of the arithmetic sequence $3, \frac{7}{3}, \frac{5}{3}, \dots$
- Find the 13th term of the arithmetic sequence \$1200, \$964.32, \$728.64, ...
- Find the 10th term of the arithmetic sequence \$2345.78, \$2967.54, \$3589.30, ...
- In the sequence of Exercise 9, what term is the number 106?

15. In the sequence of Exercise 8, what term is the number 1.67?
16. In the sequence of Exercise 10, what term is -296 ?
17. In the sequence of Exercise 11, what term is -27 ?
18. Find a_{20} when $a_1 = 14$ and $d = -3$.
19. Find a_1 when $d = 4$ and $a_8 = 33$.
20. Find d when $a_1 = 8$ and $a_{11} = 26$.
21. Find n when $a_1 = 25$, $d = -14$, and $a_n = -507$.
22. In an arithmetic sequence, $a_{17} = -40$ and $a_{28} = -73$. Find a_1 and d . Write the first 5 terms of the sequence.
23. In an arithmetic sequence, $a_{17} = \frac{25}{3}$ and $a_{32} = \frac{95}{6}$. Find a_1 and d . Write the first 5 terms of the sequence.
24. Find the sum of the first 14 terms of the series $11 + 7 + 3 + \cdots$.
25. Find the sum of the first 20 terms of the series $5 + 8 + 11 + 14 + \cdots$.
26. Find the sum of the first 300 natural numbers.
27. Find the sum of the first 400 even natural numbers.
28. Find the sum of the odd numbers 1 to 199, inclusive.
29. Find the sum of the multiples of 7 from 7 to 98, inclusive.
30. Find the sum of all multiples of 4 that are between 14 and 523.
31. If an arithmetic series has $a_1 = 2$, $d = 5$, and $n = 20$, what is S_n ?
32. If an arithmetic series has $a_1 = 7$, $d = -3$, and $n = 32$, what is S_n ?

Find the sum.

$$33. \sum_{k=1}^{40} (2k + 3)$$

$$34. \sum_{k=5}^{20} 8k$$

$$35. \sum_{k=0}^{19} \frac{k-3}{4}$$

$$36. \sum_{k=2}^{50} (2000 - 3k)$$

$$37. \sum_{k=12}^{57} \frac{7-4k}{13}$$

$$38. \sum_{k=101}^{200} (1.14k - 2.8) - \sum_{k=1}^5 \left(\frac{k+4}{10} \right)$$

39. **Stacking Poles.** How many poles will be in a stack of telephone poles if there are 50 in the first layer, 49 in the second, and so on, with 6 in the top layer?
40. **Investment Return.** Max sets up an investment situation for a client that will return \$5000 the first year, \$6125 the second year, \$7250 the third year, and so on, for 25 yr. How much is received from the investment altogether?
41. **Total Savings.** If 10¢ is saved on October 1, 20¢ is saved on October 2, 30¢ on October 3, and so on, how much is saved during the 31 days of October?
42. **Theater Seating.** Theaters are often built with more seats per row as the rows move toward the back. Suppose that the first balcony of a theater has 28 seats in the first row, 32 in the second, 36 in the third, and so on, for 20 rows. How many seats are in the first balcony altogether?

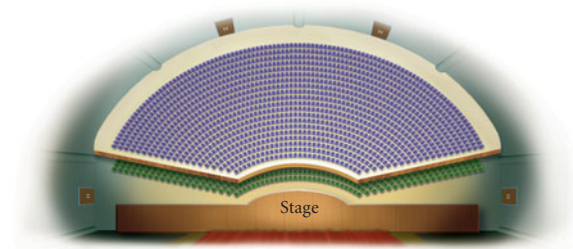

43. **Parachutist Free Fall.** When a parachutist jumps from an airplane, the distances, in feet, that the parachutist falls in each successive second before pulling the ripcord to release the parachute are as follows:

16, 48, 80, 112, 144, . . .

Is this sequence arithmetic? What is the common difference? What is the total distance fallen in 10 sec?



44. **Small Group Interaction.** In a social science study, Stephan found the following data regarding an interaction measurement r_n for groups of size n .

n	r_n
3	0.5908
4	0.6080
5	0.6252
6	0.6424
7	0.6596
8	0.6768
9	0.6940
10	0.7112

Source: *American Sociological Review*, 17 (1952)

Is this sequence arithmetic? What is the common difference?

45. **Garden Plantings.** A gardener is making a planting in the shape of a trapezoid. It will have 35 plants in the front row, 31 in the second row, 27 in the third row, and so on. If the pattern is consistent, how many plants will there be in the last row? How many plants are there altogether?
46. **Band Formation.** A formation of a marching band has 10 marchers in the front row, 12 in the second row, 14 in the third row, and so on, for 8 rows. How many marchers are in the last row? How many marchers are there altogether?
47. **Raw Material Production.** In a manufacturing process, it took 3 units of raw materials to produce 1 unit of a product. The raw material needs thus formed the sequence

$$3, 6, 9, \dots, 3n, \dots$$

Is this sequence arithmetic? What is the common difference?

Skill Maintenance

Solve.

48. $7x - 2y = 4,$
 $x + 3y = 17$
49. $2x + y + 3z = 12,$
 $x - 3y + 2z = 11,$
 $5x + 2y - 4z = -4$

50. Find the vertices and the foci of the ellipse with the equation $9x^2 + 16y^2 = 144$.
51. Find an equation of the ellipse with vertices $(0, -5)$ and $(0, 5)$ and minor axis of length 4.

Synthesis

52. Find three numbers in an arithmetic sequence such that the sum of the first and third is 10 and the product of the first and second is 15.
53. Find a formula for the sum of the first n odd natural numbers:

$$1 + 3 + 5 + \dots + (2n - 1).$$

54. Find the first 10 terms of the arithmetic sequence for which

$$a_1 = \$8760 \quad \text{and} \quad d = -\$798.23.$$

Then find the sum of the first 10 terms.

55. Find the first term and the common difference for the arithmetic sequence for which

$$a_2 = 40 - 3q \quad \text{and} \quad a_4 = 10p + q.$$

56. The zeros of this polynomial function form an arithmetic sequence. Find them.

$$f(x) = x^4 + 4x^3 - 84x^2 - 176x + 640$$

If p , m , and q form an arithmetic sequence, it can be shown that $m = (p + q)/2$. (See Exercise 63.) The number m is the **arithmetic mean**, or **average**, of p and q . Given two numbers p and q , if we find k other numbers m_1, m_2, \dots, m_k such that

$$p, m_1, m_2, \dots, m_k, q$$

forms an arithmetic sequence, we say that we have “inserted k arithmetic means between p and q .”

57. Insert three arithmetic means between 4 and 12.
58. Insert three arithmetic means between -3 and 5.
59. Insert four arithmetic means between 4 and 13.
60. Insert ten arithmetic means between 27 and 300.
61. Insert enough arithmetic means between 1 and 50 so that the sum of the resulting series will be 459.
62. **Straight-Line Depreciation.** A company buys an office machine for \$5200 on January 1 of a given year. The machine is expected to last for 8 yr, at the end of which time its **trade-in value**, or **salvage value**, will be \$1100. If the company's accountant

figures the decline in value to be the same each year, then its **book values**, or **salvage values**, after t years, $0 \leq t \leq 8$, form an arithmetic sequence given by

$$a_t = C - t \left(\frac{C - S}{N} \right),$$

where C is the original cost of the item (\$5200), N is the number of years of expected life (8), and S is the salvage value (\$1100).

- Find the formula for a_t for the straight-line depreciation of the office machine.
- Find the salvage value after 0 yr, 1 yr, 2 yr, 3 yr, 4 yr, 7 yr, and 8 yr.

63. Prove that if p , m , and q form an arithmetic sequence, then

$$m = \frac{p + q}{2}.$$

Geometric Sequences and Series

11.3

- ▶ Identify the common ratio of a geometric sequence, and find a given term and the sum of the first n terms.
- ▶ Find the sum of an infinite geometric series, if it exists.

A sequence in which each term after the first is found by multiplying the preceding term by the same number is a **geometric sequence**.

▶ Geometric Sequences

Consider the sequence:

$$2, 6, 18, 54, 162, \dots$$

Note that multiplying each term by 3 produces the next term. We call the number 3 the **common ratio** because it can be found by dividing any term by the preceding term. A geometric sequence is also called a *geometric progression*.

Geometric Sequence

A sequence is **geometric** if there is a number r , called the **common ratio**, such that

$$\frac{a_{n+1}}{a_n} = r, \quad \text{or} \quad a_{n+1} = a_n r, \quad \text{for any integer } n \geq 1.$$

EXAMPLE 1 For each of the following geometric sequences, identify the common ratio.

a) 3, 6, 12, 24, 48, ...

b) $1, -\frac{1}{2}, \frac{1}{4}, -\frac{1}{8}, \dots$

c) \$5200, \$3900, \$2925, \$2193.75, ... d) \$1000, \$1060, \$1123.60, ...

Solution

SEQUENCE	COMMON RATIO
a) 3, 6, 12, 24, 48, ...	2 $\left(\frac{6}{3} = 2, \frac{12}{6} = 2, \text{ and so on}\right)$
b) $1, -\frac{1}{2}, \frac{1}{4}, -\frac{1}{8}, \dots$	$-\frac{1}{2}$ $\left(\frac{-\frac{1}{2}}{1} = -\frac{1}{2}, \frac{\frac{1}{4}}{-\frac{1}{2}} = -\frac{1}{2}, \text{ and so on}\right)$
c) \$5200, \$3900, \$2925, \$2193.75, ...	0.75 $\left(\frac{\$3900}{\$5200} = 0.75, \frac{\$2925}{\$3900} = 0.75, \text{ and so on}\right)$
d) \$1000, \$1060, \$1123.60, ...	1.06 $\left(\frac{\$1060}{\$1000} = 1.06, \frac{\$1123.60}{\$1060} = 1.06, \text{ and so on}\right)$

 **Now Try Exercise 1.**

We now find a formula for the general, or n th, term of a geometric sequence. Let a_1 be the first term and r the common ratio. The first few terms are as follows:

$$a_1,$$

$$a_2 = a_1 r,$$

$$a_3 = a_2 r = (a_1 r) r = a_1 r^2, \quad \text{Substituting } a_1 r \text{ for } a_2$$

$$a_4 = a_3 r = (a_1 r^2) r = a_1 r^3. \quad \text{Substituting } a_1 r^2 \text{ for } a_3$$

 **Note that the exponent is 1 less than the subscript.**

Generalizing, we obtain the following.

***n*th Term of a Geometric Sequence**

The n th term of a geometric sequence is given by

$$a_n = a_1 r^{n-1}, \quad \text{for any integer } n \geq 1.$$

EXAMPLE 2 Find the 7th term of the geometric sequence 4, 20, 100, ...

Solution We first note that

$$a_1 = 4 \quad \text{and} \quad n = 7.$$

To find the common ratio, we can divide any term (other than the first) by the preceding term. Since the second term is 20 and the first is 4, we get

$$r = \frac{20}{4}, \quad \text{or} \quad 5.$$

Then using the formula $a_n = a_1 r^{n-1}$, we have

$$a_7 = 4 \cdot 5^{7-1} = 4 \cdot 5^6 = 4 \cdot 15,625 = 62,500.$$

Thus the 7th term is 62,500.

 **Now Try Exercise 11.**

EXAMPLE 3 Find the 10th term of the geometric sequence 64, -32, 16, -8, ...

Solution We first note that

$$a_1 = 64, \quad n = 10, \quad \text{and} \quad r = \frac{-32}{64}, \text{ or } -\frac{1}{2}.$$

Then using the formula $a_n = a_1 r^{n-1}$, we have

$$a_{10} = 64 \cdot \left(-\frac{1}{2}\right)^{10-1} = 64 \cdot \left(-\frac{1}{2}\right)^9 = 2^6 \cdot \left(-\frac{1}{2^9}\right) = -\frac{1}{2^3} = -\frac{1}{8}.$$

Thus the 10th term is $-\frac{1}{8}$.

 **Now Try Exercise 15.**

► Sum of the First n Terms of a Geometric Sequence

Next, we develop a formula for the sum S_n of the first n terms of a geometric sequence:

$$a_1, a_1 r, a_1 r^2, a_1 r^3, \dots, a_1 r^{n-1}, \dots$$

The associated **geometric series** is given by

$$S_n = a_1 + a_1 r + a_1 r^2 + a_1 r^3 + \cdots + a_1 r^{n-1}. \quad (1)$$

We want to find a formula for this sum. If we multiply on both sides of equation (1) by r , we have

$$rS_n = a_1 r + a_1 r^2 + a_1 r^3 + a_1 r^4 + \cdots + a_1 r^n. \quad (2)$$

Subtracting equation (2) from equation (1), we see that the differences of the terms shown in red are 0, leaving

$$S_n - rS_n = a_1 - a_1 r^n,$$

or

$$S_n(1 - r) = a_1(1 - r^n). \quad \text{Factoring}$$

Dividing on both sides by $1 - r$ gives us the following formula.

Sum of the First n Terms

The sum of the first n terms of a geometric sequence is given by

$$S_n = \frac{a_1(1 - r^n)}{1 - r}, \quad \text{for any } r \neq 1.$$

EXAMPLE 4 Find the sum of the first 7 terms of the geometric sequence 3, 15, 75, 375,

Solution We first note that

$$a_1 = 3, \quad n = 7, \quad \text{and} \quad r = \frac{15}{3}, \text{ or } 5.$$

Then using the formula

$$S_n = \frac{a_1(1 - r^n)}{1 - r},$$

we have

$$\begin{aligned} S_7 &= \frac{3(1 - 5^7)}{1 - 5} \\ &= \frac{3(1 - 78,125)}{-4} \\ &= 58,593. \end{aligned}$$

Thus the sum of the first 7 terms is 58,593.

➔ Now Try Exercise 23.

EXAMPLE 5 Find the sum: $\sum_{k=1}^{11} (0.3)^k$.

Solution This is a geometric series with $a_1 = 0.3$, $r = 0.3$, and $n = 11$. Thus,

$$\begin{aligned} S_{11} &= \frac{0.3(1 - 0.3^{11})}{1 - 0.3} \\ &\approx 0.42857. \end{aligned}$$

➔ Now Try Exercise 41.

► Infinite Geometric Series

The sum of the terms of an infinite geometric sequence is an **infinite geometric series**. For some geometric sequences, S_n gets close to a specific number as n gets large. For example, consider the infinite series

$$\frac{1}{2} + \frac{1}{4} + \frac{1}{8} + \frac{1}{16} + \cdots + \frac{1}{2^n} + \cdots.$$

We can visualize S_n by considering the area of a square. For S_1 , we shade half the square. For S_2 , we shade half the square plus half the remaining half, or $\frac{3}{4}$. For S_3 , we shade the parts shaded in S_2 plus half the remaining part. We see that the values of S_n will get close to 1 (shading the complete square).

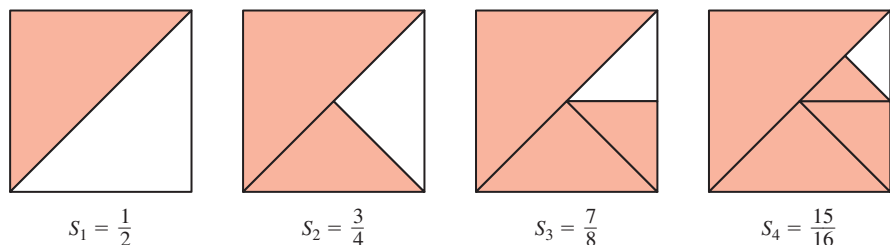

We examine some partial sums. Note that each of the partial sums is less than 1, but S_n gets very close to 1 as n gets large.

n	S_n
1	0.5
5	0.96875
10	0.9990234375
20	0.9999990463
30	0.9999999991

We say that 1 is the **limit** of S_n and also that 1 is the **sum of the infinite geometric sequence**. The sum of an infinite geometric sequence is denoted S_∞ . In this case, $S_\infty = 1$.

Some infinite sequences do not have sums. Consider the infinite geometric series

$$2 + 4 + 8 + 16 + \cdots + 2^n + \cdots.$$

We again examine some partial sums. Note that as n gets large, S_n gets large without bound. This sequence does not have a sum.

n	S_n
1	2
5	62
10	2,046
20	2,097,150
30	2,147,483,646

It can be shown (but we will not do so here) that the sum of an infinite geometric series exists if and only if $|r| < 1$ (that is, the absolute value of the common ratio is less than 1).

To find a formula for the sum of an infinite geometric series, we first consider the sum of the first n terms:

$$S_n = \frac{a_1(1 - r^n)}{1 - r} = \frac{a_1 - a_1r^n}{1 - r}. \quad \text{Using the distributive law}$$

For $|r| < 1$, values of r^n get close to 0 as n gets large. As r^n gets close to 0, so does a_1r^n . Thus, S_n gets close to $a_1/(1 - r)$.

Limit or Sum of an Infinite Geometric Series

When $|r| < 1$, the limit or sum of an infinite geometric series is given by

$$S_\infty = \frac{a_1}{1 - r}.$$

EXAMPLE 6 Determine whether each of the following infinite geometric series has a limit. If a limit exists, find it.

a) $1 + 3 + 9 + 27 + \cdots$ b) $-2 + 1 - \frac{1}{2} + \frac{1}{4} - \frac{1}{8} + \cdots$

Solution

a) Here $r = 3$, so $|r| = |3| = 3$. Since $|r| > 1$, the series *does not* have a limit.

b) Here $r = -\frac{1}{2}$, so $|r| = |-\frac{1}{2}| = \frac{1}{2}$. Since $|r| < 1$, the series *does* have a limit. We find the limit:

$$S_{\infty} = \frac{a_1}{1 - r} = \frac{-2}{1 - (-\frac{1}{2})} = \frac{-2}{\frac{3}{2}} = -\frac{4}{3}.$$

 **Now Try Exercises 33 and 37.**

EXAMPLE 7 Find fraction notation for $0.78787878\dots$, or $0.\overline{78}$.

Solution We can express this as

$$0.78 + 0.0078 + 0.000078 + \cdots.$$

Then we see that this is an infinite geometric series, where $a_1 = 0.78$ and $r = 0.01$. Since $|r| < 1$, this series has a limit:

$$S_{\infty} = \frac{a_1}{1 - r} = \frac{0.78}{1 - 0.01} = \frac{0.78}{0.99} = \frac{78}{99}, \text{ or } \frac{26}{33}.$$

Thus fraction notation for $0.78787878\dots$ is $\frac{26}{33}$. You can check this on your calculator.

 **Now Try Exercise 51.**

Applications

The translation of some applications and problem-solving situations may involve geometric sequences or series. Examples 9 and 10, in particular, show applications in business and economics.

EXAMPLE 8 *A Daily Doubling Salary.* Suppose someone offered you a job for the month of September (30 days) under the following conditions. You will be paid \$0.01 for the first day, \$0.02 for the second, \$0.04 for the third, and so on, doubling your previous day's salary each day. How much would you earn? (Would you take the job? Make a conjecture before reading further.)

Solution You earn \$0.01 the first day, \$0.01(2) the second day, \$0.01(2)(2) the third day, and so on. The amount earned is the geometric series

$$\$0.01 + \$0.01(2) + \$0.01(2^2) + \$0.01(2^3) + \cdots + \$0.01(2^{29}),$$

where $a_1 = \$0.01$, $r = 2$, and $n = 30$. Using the formula

$$S_n = \frac{a_1(1 - r^n)}{1 - r},$$

we have

$$S_{30} = \frac{\$0.01(1 - 2^{30})}{1 - 2} = \$10,737,418.23.$$

The pay exceeds \$10.7 million for the month.

 **Now Try Exercise 57.**

EXAMPLE 9 *The Amount of an Annuity.* An **annuity** is a sequence of equal payments, made at equal time intervals, that earn interest. Fixed deposits in a savings account are an example of an annuity. Suppose that to save money to buy a car, Andrea deposits \$1000 at the *end* of each of 5 yr in an account that pays 8% interest, compounded annually. The total amount in the account at the end of 5 yr is called the **amount of the annuity**. Find that amount.

Solution The following time diagram can help visualize the problem. Note that no deposit is made until the end of the first year.

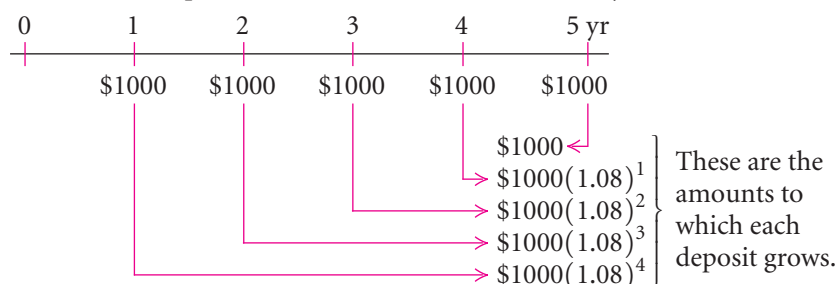

The amount of the annuity is the geometric series $\$1000 + \$1000(1.08)^1 + \$1000(1.08)^2 + \$1000(1.08)^3 + \$1000(1.08)^4$, where $a_1 = \$1000$, $n = 5$, and $r = 1.08$. Using the formula

$$S_n = \frac{a_1(1 - r^n)}{1 - r},$$

we have

$$S_5 = \frac{\$1000(1 - 1.08^5)}{1 - 1.08} \approx \$5866.60.$$

The amount of the annuity is \$5866.60.

Now Try Exercise 61.

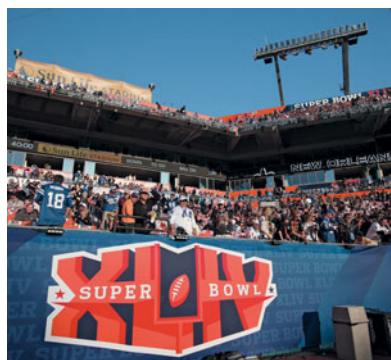

EXAMPLE 10 *The Economic Multiplier.* Large sporting events have a significant impact on the economy of the host city. Those attending the 2010 Super Bowl in Miami poured \$333 million into the economy of south Florida (*Source*: Sport Management Research Institute). Assume that 60% of that amount is spent again in the area, and then 60% of that amount is spent again, and so on. This is known as the *economic multiplier effect*. Find the total effect on the economy.

Solution The total economic effect is given by the infinite series

$$\$333,000,000 + \$333,000,000(0.6) + \$333,000,000(0.6)^2 + \cdots.$$

Since $|r| = |0.6| = 0.6 < 1$, the series has a sum. Using the formula for the sum of an infinite geometric series, we have

$$S_\infty = \frac{a_1}{1 - r} = \frac{\$333,000,000}{1 - 0.6} = \$832,500,000.$$

The total effect of the spending on the economy is \$832,500,000.

Now Try Exercise 65.

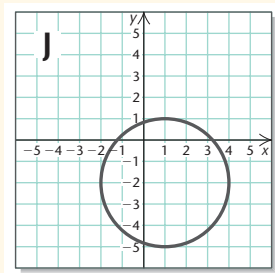
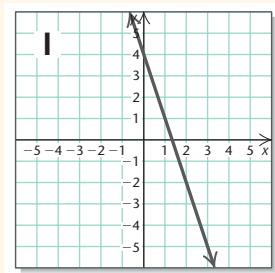
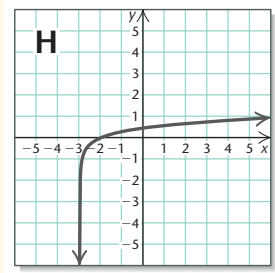
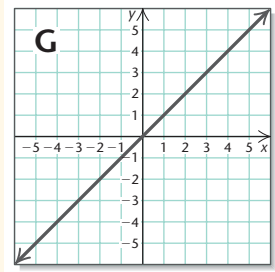
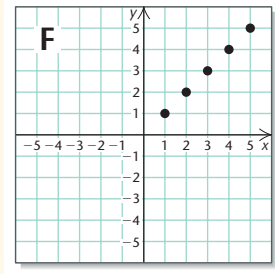
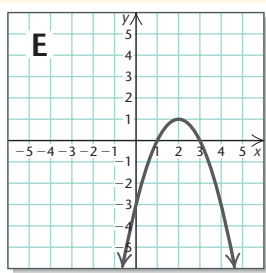
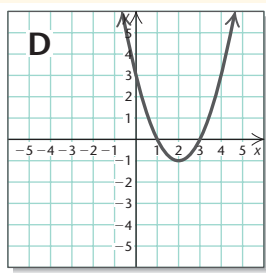
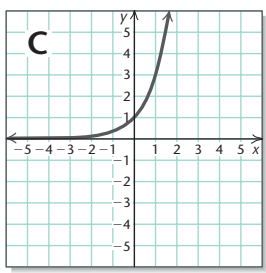
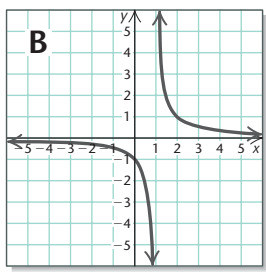
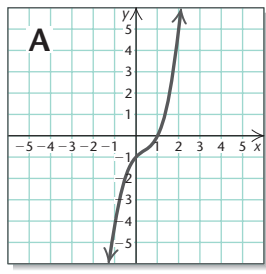

Visualizing the Graph

Match the equation with its graph.

1. $(x - 1)^2 + (y + 2)^2 = 9$
2. $y = x^3 - x^2 + x - 1$
3. $f(x) = 3^x$
4. $f(x) = x$
5. $a_n = n$
6. $y = \log(x + 3)$
7. $f(x) = -(x - 2)^2 + 1$
8. $f(x) = (x - 2)^2 - 1$
9. $y = \frac{1}{x - 1}$
10. $y = -3x + 4$

Answers on page A-73

11.3

Exercise Set

Find the common ratio.

- 2, 4, 8, 16, ...
- 18, -6, 2, $-\frac{2}{3}$, ...
- 1, 1, -1, 1, ...
- 8, -0.8, -0.08, -0.008, ...
- $\frac{2}{3}$, $-\frac{4}{3}$, $\frac{8}{3}$, $-\frac{16}{3}$, ...
- 75, 15, 3, $\frac{3}{5}$, ...
- 6.275, 0.6275, 0.06275, ...
- $\frac{1}{x}$, $\frac{1}{x^2}$, $\frac{1}{x^3}$, ...
- 5, $\frac{5a}{2}$, $\frac{5a^2}{4}$, $\frac{5a^3}{8}$, ...
- \$780, \$858, \$943.80, \$1038.18, ...

Find the indicated term.

- 2, 4, 8, 16, ...; the 7th term
- 2, -10, 50, -250, ...; the 9th term
- 2, $2\sqrt{3}$, 6, ...; the 9th term
- 1, -1, 1, -1, ...; the 57th term
- $\frac{7}{625}$, $-\frac{7}{25}$, ...; the 23rd term
- \$1000, \$1060, \$1123.60, ...; the 5th term

Find the n th, or general, term.

- 1, 3, 9, ...
- 25, 5, 1, ...
- 1, -1, 1, -1, ...
- 2, 4, -8, ...

$$21. \frac{1}{x}, \frac{1}{x^2}, \frac{1}{x^3}, \dots$$

$$22. 5, \frac{5a}{2}, \frac{5a^2}{4}, \frac{5a^3}{8}, \dots$$

- Find the sum of the first 7 terms of the geometric series

$$6 + 12 + 24 + \dots$$

- Find the sum of the first 10 terms of the geometric series

$$16 - 8 + 4 - \dots$$

- Find the sum of the first 9 terms of the geometric series

$$\frac{1}{18} - \frac{1}{6} + \frac{1}{2} - \dots$$

- Find the sum of the geometric series

$$-8 + 4 + (-2) + \dots + \left(-\frac{1}{32}\right).$$

Determine whether the statement is true or false.

- The sequence 2, $-2\sqrt{2}$, 4, $-4\sqrt{2}$, 8, ... is geometric.
- The sequence with general term $3n$ is geometric.
- The sequence with general term 2^n is geometric.
- Multiplying a term of a geometric sequence by the common ratio produces the next term of the sequence.
- An infinite geometric series with common ratio -0.75 has a sum.

- Every infinite geometric series has a limit.

Find the sum, if it exists.

$$33. 4 + 2 + 1 + \dots$$

$$34. 7 + 3 + \frac{9}{7} + \dots$$

$$35. 25 + 20 + 16 + \dots$$

$$36. 100 - 10 + 1 - \frac{1}{10} + \dots$$

$$37. 8 + 40 + 200 + \dots$$

$$38. -6 + 3 - \frac{3}{2} + \frac{3}{4} - \dots$$

$$39. 0.6 + 0.06 + 0.006 + \dots$$

$$40. \sum_{k=0}^{10} 3^k$$

$$42. \sum_{k=0}^{50} 200(1.08)^k$$

$$44. \sum_{k=1}^{\infty} 2^k$$

$$46. \sum_{k=1}^{\infty} 400(1.0625)^k$$

$$41. \sum_{k=1}^{11} 15\left(\frac{2}{3}\right)^k$$

$$43. \sum_{k=1}^{\infty} \left(\frac{1}{2}\right)^{k-1}$$

$$45. \sum_{k=1}^{\infty} 12.5^k$$

$$47. \sum_{k=1}^{\infty} \$500(1.11)^{-k}$$

48. $\sum_{k=1}^{\infty} \$1000(1.06)^{-k}$

49. $\sum_{k=1}^{\infty} 16(0.1)^{k-1}$

50. $\sum_{k=1}^{\infty} \frac{8}{3} \left(\frac{1}{2}\right)^{k-1}$

Find fraction notation.

51. $0.131313\dots$, or $0.\overline{13}$

52. $0.2222\dots$, or $0.\overline{2}$

53. $8.9999\overline{9}$

54. $6.1616\overline{16}$

55. $3.4125\overline{125}$

56. $12.7809\overline{809}$

57. **Daily Doubling Salary.** Suppose someone offered you a job for the month of February (28 days) under the following conditions. You will be paid \$0.01 the 1st day, \$0.02 the 2nd, \$0.04 the 3rd, and so on, doubling your previous day's salary each day. How much would you earn altogether?

58. **Bouncing Ping-Pong Ball.** A ping-pong ball is dropped from a height of 16 ft and always rebounds $\frac{1}{4}$ of the distance fallen.

- a) How high does it rebound the 6th time?
- b) Find the total sum of the rebound heights of the ball.

59. **Bungee Jumping.** A bungee jumper always rebounds 60% of the distance fallen. A bungee jump is made using a cord that stretches to 200 ft.

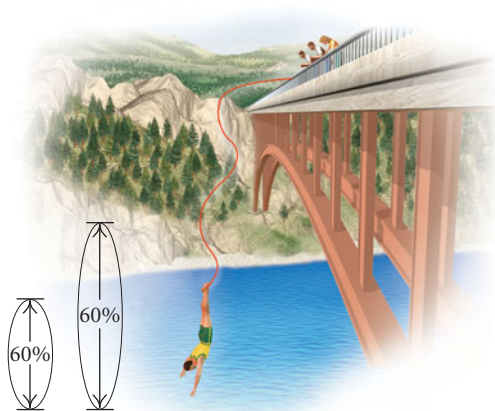

- a) After jumping and then rebounding 9 times, how far has a bungee jumper traveled upward (the total rebound distance)?
- b) About how far will a jumper have traveled upward (bounced) before coming to rest?

60. **Population Growth.** Hadleytown has a present population of 100,000, and the population is increasing by 3% each year.

- a) What will the population be in 15 yr?
- b) How long will it take for the population to double?

61. **Amount of an Annuity.** To create a college fund, a parent makes a sequence of 18 yearly deposits of \$1000 each in a savings account on which interest is compounded annually at 3.2%. Find the amount of the annuity.

62. **Amount of an Annuity.** A sequence of yearly payments of P dollars is invested at the end of each of N years at interest rate i , compounded annually. The total amount in the account, or the amount of the annuity, is V .

- a) Show that

$$V = \frac{P[(1+i)^N - 1]}{i}$$

- b) Suppose that interest is compounded n times per year and deposits are made every compounding period. Show that the formula for V is then given by

$$V = \frac{P \left[\left(1 + \frac{i}{n}\right)^{nN} - 1 \right]}{i/n}$$

63. **Loan Repayment.** A family borrows \$120,000. The loan is to be repaid in 13 yr at 12% interest, compounded annually. How much will have been repaid at the end of 13 yr?

64. **Doubling the Thickness of Paper.** A piece of paper is 0.01 in. thick. It is cut and stacked repeatedly in such a way that its thickness is doubled each time for 20 times. How thick is the result?

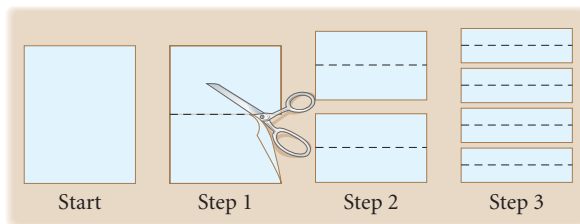

65. **The Economic Multiplier.** Suppose the government is making a \$13,000,000,000 expenditure to stimulate the economy. If 85% of this is spent again, and so on, what is the total effect on the economy?
66. **Advertising Effect.** Gigi's Cupcake Truck is about to open for business in a city of 3,000,000 people, traveling to several curbside locations in the city each day to sell cupcakes. The owners plan an advertising campaign that they think will induce 30% of the people to buy their cupcakes. They estimate that if those people like the product, they will induce $30\% \cdot 30\% \cdot 3,000,000$ more to buy the product, and those will induce $30\% \cdot 30\% \cdot 30\% \cdot 3,000,000$ and so on. In all, how many people will buy Gigi's cupcakes as a result of the advertising campaign? What percentage of the population is this?

Skill Maintenance

For each pair of functions, find $(f \circ g)(x)$ and $(g \circ f)(x)$.

67. $f(x) = x^2$, $g(x) = 4x + 5$

68. $f(x) = x - 1$, $g(x) = x^2 + x + 3$

Solve.

69. $5^x = 35$

70. $\log_2 x = -4$

Synthesis

71. Prove that $\sqrt{3} - \sqrt{2}$, $4 - \sqrt{6}$, and $6\sqrt{3} - 2\sqrt{2}$ form a geometric sequence.
72. Consider the sequence
 $4, 20.4, 104.04, 531.6444, \dots$
 What is the error in using $a_{277} = 4(5.1)^{276}$ to find the 277th term?

73. Consider the sequence

$$x + 3, x + 7, 4x - 2, \dots$$

- a) If the sequence is arithmetic, find x and then determine each of the 3 terms and the 4th term.
 b) If the sequence is geometric, find x and then determine each of the 3 terms and the 4th term.

74. Find the sum of the first n terms of

$$1 + x + x^2 + \dots$$

75. Find the sum of the first n terms of

$$x^2 - x^3 + x^4 - x^5 + \dots$$

In Exercises 76 and 77, assume that a_1, a_2, a_3, \dots is a geometric sequence.

76. Prove that $a_1^2, a_2^2, a_3^2, \dots$ is a geometric sequence.
 77. Prove that $\ln a_1, \ln a_2, \ln a_3, \dots$ is an arithmetic sequence.
 78. Prove that $5^{a_1}, 5^{a_2}, 5^{a_3}, \dots$ is a geometric sequence, if a_1, a_2, a_3, \dots is an arithmetic sequence.
 79. The sides of a square are 16 cm long. A second square is inscribed by joining the midpoints of the sides, successively. In the second square, we repeat the process, inscribing a third square. If this process is continued indefinitely, what is the sum of all the areas of all the squares? (*Hint*: Use an infinite geometric series.)

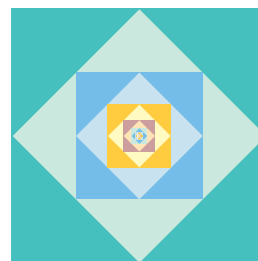

Mathematical Induction

11.4

► Prove infinite sequences of statements using mathematical induction.

In this section, we learn to prove a sequence of mathematical statements using a procedure called *mathematical induction*.

► Proving Infinite Sequences of Statements

Infinite sequences of statements occur often in mathematics. In an infinite sequence of statements, there is a statement for each natural number. For example, consider the sequence of statements represented by the following:

$$\text{“The sum of the first } n \text{ positive odd integers is } n^2\text{,” or} \\ 1 + 3 + 5 + \cdots + (2n - 1) = n^2.$$

Let's think of this as $S(n)$, or S_n . Substituting natural numbers for n gives a sequence of statements. We list the first four:

$$S_1: 1 = 1^2;$$

$$S_2: 1 + 3 = 4 = 2^2;$$

$$S_3: 1 + 3 + 5 = 9 = 3^2;$$

$$S_4: 1 + 3 + 5 + 7 = 16 = 4^2.$$

The fact that the statement is true for $n = 1, 2, 3,$ and 4 might tempt us to conclude that the statement is true for any natural number n , but we cannot be sure that this is the case. We can, however, use the principle of mathematical induction to prove that the statement is true for all natural numbers.

The Principle of Mathematical Induction

We can prove an infinite sequence of statements S_n by showing the following.

- (1) *Basis step.* S_1 is true.
- (2) *Induction step.* For all natural numbers k , $S_k \rightarrow S_{k+1}$.

Mathematical induction is analogous to lining up a sequence of dominoes. The induction step tells us that if any one domino is knocked over, then the one next to it will be hit and knocked over. The basis step tells us

that the first domino can indeed be knocked over. Note that in order for all dominoes to fall, *both* conditions must be satisfied.

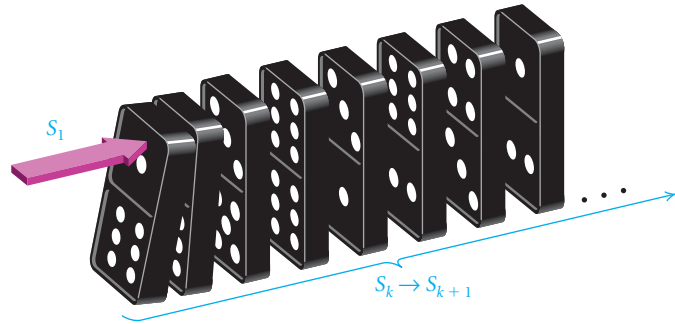

When you are learning to do proofs by mathematical induction, it is helpful to first write out S_n , S_1 , S_k , and S_{k+1} . This helps to identify what is to be assumed and what is to be deduced.

EXAMPLE 1 Prove: For every natural number n ,

$$1 + 3 + 5 + \cdots + (2n - 1) = n^2.$$

Proof. We first write out S_n , S_1 , S_k , and S_{k+1} .

$$S_n: \quad 1 + 3 + 5 + \cdots + (2n - 1) = n^2$$

$$S_1: \quad 1 = 1^2$$

$$S_k: \quad 1 + 3 + 5 + \cdots + (2k - 1) = k^2$$

$$S_{k+1}: \quad 1 + 3 + 5 + \cdots + (2k - 1) + [2(k + 1) - 1] = (k + 1)^2$$

- (1) *Basis step.* S_1 , as listed, is true since $1 = 1^2$, or $1 = 1$.
- (2) *Induction step.* We let k be any natural number. We assume S_k to be true and try to show that it implies that S_{k+1} is true. Now S_k is

$$1 + 3 + 5 + \cdots + (2k - 1) = k^2.$$

Starting with the left side of S_{k+1} and substituting k^2 for $1 + 3 + 5 + \cdots + (2k - 1)$, we have

$$\underbrace{1 + 3 + \cdots + (2k - 1)} + [2(k + 1) - 1]$$

$$\begin{aligned} & \downarrow \\ & = k^2 + [2(k + 1) - 1] && \text{We assume } S_k \text{ is true.} \\ & = k^2 + 2k + 2 - 1 \\ & = k^2 + 2k + 1 \\ & = (k + 1)^2. \end{aligned}$$

We have shown that for all natural numbers k , $S_k \rightarrow S_{k+1}$. This completes the induction step. It and the basis step tell us that the proof is complete.

Now Try Exercise 5.

EXAMPLE 2 Prove: For every natural number n ,

$$\frac{1}{2} + \frac{1}{4} + \frac{1}{8} + \cdots + \frac{1}{2^n} = \frac{2^n - 1}{2^n}.$$

Proof. We first list S_n , S_1 , S_k , and S_{k+1} .

$$S_n: \quad \frac{1}{2} + \frac{1}{4} + \frac{1}{8} + \cdots + \frac{1}{2^n} = \frac{2^n - 1}{2^n}$$

$$S_1: \quad \frac{1}{2^1} = \frac{2^1 - 1}{2^1}$$

$$S_k: \quad \frac{1}{2} + \frac{1}{4} + \frac{1}{8} + \cdots + \frac{1}{2^k} = \frac{2^k - 1}{2^k}$$

$$S_{k+1}: \quad \frac{1}{2} + \frac{1}{4} + \frac{1}{8} + \cdots + \frac{1}{2^k} + \frac{1}{2^{k+1}} = \frac{2^{k+1} - 1}{2^{k+1}}$$

(1) *Basis step.* We show S_1 to be true as follows:

$$\frac{2^1 - 1}{2^1} = \frac{2 - 1}{2} = \frac{1}{2}.$$

(2) *Induction step.* We let k be any natural number. We assume S_k to be true and try to show that it implies that S_{k+1} is true. Now S_k is

$$\frac{1}{2} + \frac{1}{4} + \frac{1}{8} + \cdots + \frac{1}{2^k} = \frac{2^k - 1}{2^k}.$$

We start with the left side of S_{k+1} . Since we assume S_k is true, we can substitute

$$\frac{2^k - 1}{2^k} \quad \text{for} \quad \frac{1}{2} + \frac{1}{4} + \cdots + \frac{1}{2^k}.$$

We have

$$\begin{aligned} & \underbrace{\frac{1}{2} + \frac{1}{4} + \frac{1}{8} + \cdots + \frac{1}{2^k}}_{\downarrow} + \frac{1}{2^{k+1}} \\ &= \frac{2^k - 1}{2^k} + \frac{1}{2^{k+1}} = \frac{2^k - 1}{2^k} \cdot \frac{2}{2} + \frac{1}{2^{k+1}} \\ &= \frac{(2^k - 1) \cdot 2 + 1}{2^{k+1}} \\ &= \frac{2^{k+1} - 2 + 1}{2^{k+1}} \\ &= \frac{2^{k+1} - 1}{2^{k+1}}. \end{aligned}$$

We have shown that for all natural numbers k , $S_k \rightarrow S_{k+1}$. This completes the induction step. It and the basis step tell us that the proof is complete.

 **Now Try Exercise 15.**

EXAMPLE 3 Prove: For every natural number n , $n < 2^n$.

Proof. We first list S_n , S_1 , S_k , and S_{k+1} .

$$\begin{aligned} S_n: & n < 2^n \\ S_1: & 1 < 2^1 \\ S_k: & k < 2^k \\ S_{k+1}: & k + 1 < 2^{k+1} \end{aligned}$$

- (1) *Basis step.* S_1 , as listed, is true since $2^1 = 2$ and $1 < 2$.
 (2) *Induction step.* We let k be any natural number. We assume S_k to be true and try to show that it implies that S_{k+1} is true. Now

$$\begin{aligned} k &< 2^k && \text{This is } S_k. \\ 2k &< 2 \cdot 2^k && \text{Multiplying by 2 on both sides} \\ 2k &< 2^{k+1} && \text{Adding exponents on the right} \\ k + k &< 2^{k+1}. && \text{Rewriting } 2k \text{ as } k + k \end{aligned}$$

Since k is any natural number, we know that $1 \leq k$. Thus,

$$k + 1 \leq k + k. \quad \text{Adding } k \text{ on both sides of } 1 \leq k$$

Putting the results $k + 1 \leq k + k$ and $k + k < 2^{k+1}$ together gives us

$$k + 1 < 2^{k+1}. \quad \text{This is } S_{k+1}.$$

We have shown that for all natural numbers k , $S_k \rightarrow S_{k+1}$. This completes the induction step. It and the basis step tell us that the proof is complete.

 **Now Try Exercise 11.**

11.4 Exercise Set

List the first five statements in the sequence that can be obtained from each of the following. Determine whether each of the five statements is true or false.

- $n^2 < n^3$
- $n^2 - n + 41$ is prime. Find a value for n for which the statement is false.
- A polygon of n sides has $[n(n - 3)]/2$ diagonals.
- The sum of the angles of a polygon of n sides is $(n - 2) \cdot 180^\circ$.

Use mathematical induction to prove each of the following.

- $2 + 4 + 6 + \cdots + 2n = n(n + 1)$
- $4 + 8 + 12 + \cdots + 4n = 2n(n + 1)$
- $1 + 5 + 9 + \cdots + (4n - 3) = n(2n - 1)$

$$8. 3 + 6 + 9 + \cdots + 3n = \frac{3n(n + 1)}{2}$$

$$9. 2 + 4 + 8 + \cdots + 2^n = 2(2^n - 1)$$

$$10. 2 \leq 2^n$$

$$11. n < n + 1$$

$$12. 3^n < 3^{n+1}$$

$$13. 2n \leq 2^n$$

$$14. \frac{1}{1 \cdot 2} + \frac{1}{2 \cdot 3} + \cdots + \frac{1}{n(n + 1)} = \frac{n}{n + 1}$$

$$15. \frac{1}{1 \cdot 2 \cdot 3} + \frac{1}{2 \cdot 3 \cdot 4} + \frac{1}{3 \cdot 4 \cdot 5} + \cdots + \frac{1}{n(n + 1)(n + 2)} = \frac{n(n + 3)}{4(n + 1)(n + 2)}$$

16. If x is any real number greater than 1, then for any natural number n , $x \leq x^n$.

The following formulas can be used to find sums of powers of natural numbers. Use mathematical induction to prove each formula.

$$17. 1 + 2 + 3 + \cdots + n = \frac{n(n+1)}{2}$$

$$18. 1^2 + 2^2 + 3^2 + \cdots + n^2 = \frac{n(n+1)(2n+1)}{6}$$

$$19. 1^3 + 2^3 + 3^3 + \cdots + n^3 = \frac{n^2(n+1)^2}{4}$$

$$20. 1^4 + 2^4 + 3^4 + \cdots + n^4 = \frac{n(n+1)(2n+1)(3n^2+3n-1)}{30}$$

$$21. 1^5 + 2^5 + 3^5 + \cdots + n^5 = \frac{n^2(n+1)^2(2n^2+2n-1)}{12}$$

Use mathematical induction to prove each of the following.

$$22. \sum_{i=1}^n (3i-1) = \frac{n(3n+1)}{2}$$

$$23. \sum_{i=1}^n i(i+1) = \frac{n(n+1)(n+2)}{3}$$

$$24. \left(1 + \frac{1}{1}\right)\left(1 + \frac{1}{2}\right)\left(1 + \frac{1}{3}\right)\cdots\left(1 + \frac{1}{n}\right) = n + 1$$

$$25. \text{The sum of } n \text{ terms of an arithmetic sequence:} \\ a_1 + (a_1 + d) + (a_1 + 2d) + \cdots + [a_1 + (n-1)d] \\ = \frac{n}{2}[2a_1 + (n-1)d]$$

Skill Maintenance

Solve.

$$26. \begin{cases} 2x - 3y = 1, \\ 3x - 4y = 3 \end{cases}$$

$$27. \begin{cases} x + y + z = 3, \\ 2x - 3y - 2z = 5, \\ 3x + 2y + 2z = 8 \end{cases}$$

28. **e-Commerce.** ebooks.com ran a one-day promotion offering a hardback title for \$24.95 and a paperback title for \$9.95. A total of 80 books were sold and \$1546 was taken in. How many of each type of book were sold?

29. **Investment.** Martin received \$104 in simple interest one year from three investments. Part is invested at 1.5%, part at 2%, and part at 3%. The amount invested at 2% is twice the amount invested at 1.5%. There is \$400 more invested at 3% than at 2%. Find the amount invested at each rate.

Synthesis

Use mathematical induction to prove each of the following.

30. The sum of n terms of a geometric sequence:

$$a_1 + a_1r + a_1r^2 + \cdots + a_1r^{n-1} = \frac{a_1 - a_1r^n}{1 - r}$$

31. $x + y$ is a factor of $x^{2n} - y^{2n}$.

Prove each of the following using mathematical induction. Do the basis step for $n = 2$.

32. For every natural number $n \geq 2$,
 $2n + 1 < 3^n$.

33. For every natural number $n \geq 2$,
 $\log_a(b_1 b_2 \cdots b_n)$
 $= \log_a b_1 + \log_a b_2 + \cdots + \log_a b_n$.

Prove each of the following for any complex numbers z_1, z_2, \dots, z_n , where $i^2 = -1$ and \bar{z} is the conjugate of z . (See Section 3.1.)

$$34. \overline{z^n} = \bar{z}^n$$

$$35. \overline{z_1 + z_2 + \cdots + z_n} = \bar{z}_1 + \bar{z}_2 + \cdots + \bar{z}_n$$

$$36. \overline{z_1 z_2 \cdots z_n} = \bar{z}_1 \cdot \bar{z}_2 \cdots \bar{z}_n$$

37. i^n is either 1, -1 , i , or $-i$.

For any integers a and b , b is a factor of a if there exists an integer c such that $a = bc$. Prove each of the following for any natural number n .

38. 2 is a factor of $n^2 + n$.

39. 3 is a factor of $n^3 + 2n$.

40. *The Tower of Hanoi Problem.* There are three pegs on a board. On one peg are n disks, each smaller than the one on which it rests. The problem is to move this pile of disks to another peg. The final order must be the same, but you can move only one disk at a time and can never place a larger disk on a smaller one.

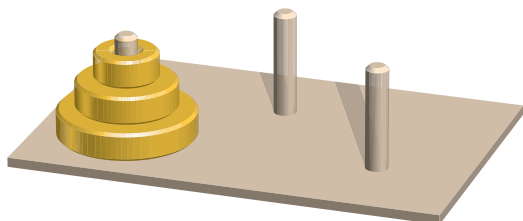

- a) What is the *smallest* number of moves needed to move 3 disks? 4 disks? 2 disks? 1 disk?
- b) Conjecture a formula for the *smallest* number of moves needed to move n disks. Prove it by mathematical induction.

Mid-Chapter Mixed Review

Determine whether the statement is true or false.

- The general term of the sequence $1, -2, 3, -4, \dots$ can be expressed as $a_n = n$. [11.1]
- To find the common difference of an arithmetic sequence, choose any term except the first and then subtract the preceding term from it. [11.2]
- The sequence $7, 3, -1, -5, \dots$ is geometric. [11.2], [11.3]
- If we can show that $S_k \rightarrow S_{k+1}$ for some natural number k , then we know that S_n is true for all natural numbers n . [11.4]

In each of the following, the n th term of a sequence is given. Find the first 4 terms, a_9 , and a_{14} .

- $a_n = 3n + 5$ [11.1]
- $a_n = (-1)^{n+1}(n - 1)$ [11.1]

Predict the general term, or n th term, a_n , of the sequence. Answers may vary.

- $3, 6, 9, 12, 15, \dots$ [11.1]
- $-1, 4, -9, 16, -25, \dots$ [11.1]
- Find the partial sum S_4 for the sequence $1, \frac{1}{2}, \frac{1}{4}, \frac{1}{8}, \frac{1}{16}, \dots$ [11.1]
- Find and evaluate the sum $\sum_{k=1}^5 k(k + 1)$. [11.1]
- Write sigma notation for the sum $-4 + 8 - 12 + 16 - 20 + \dots$ [11.1]
- Find the first 4 terms of the sequence defined by $a_1 = 2, a_{n+1} = 4a_n - 2$. [11.1]
- Find the common difference of the arithmetic sequence $12, 7, 2, -3, \dots$ [11.2]
- Find the 10th term of the arithmetic sequence $4, 6, 8, 10, \dots$ [11.2]
- In the sequence in Exercise 14, what term is the number 44? [11.2]
- Find the sum of the first 16 terms of the arithmetic series $6 + 11 + 16 + 21 + \dots$. [11.2]

17. Find the common ratio of the geometric sequence $16, -8, 4, -2, 1, \dots$ [11.3]
18. Find (a) the 8th term and (b) the sum of the first 10 terms of the geometric sequence $\frac{1}{16}, \frac{1}{8}, \frac{1}{4}, \frac{1}{2}, 1, \dots$ [11.3]
- Find the sum, if it exists.
19. $-8 + 4 - 2 + 1 - \dots$ [11.3]
20. $\sum_{k=0}^{\infty} 5^k$ [11.3]
21. **Landscaping.** A landscaper is planting a triangular flower bed with 36 plants in the first row, 30 plants in the second row, 24 in the third row, and so on, for a total of 6 rows. How many plants will be planted in all? [11.2]
22. **Amount of an Annuity.** To save money for adding a bedroom to their home, at the end of each of 4 yr the Davidsons deposit \$1500 in an account that pays 4% interest, compounded annually. Find the total amount of the annuity. [11.3]
23. Prove: For every natural number n , $1 + 4 + 7 + \dots + (3n - 2) = \frac{1}{2}n(3n - 1)$. [11.4]

Collaborative Discussion and Writing

24. The sum of the first n terms of an arithmetic sequence can be given by
- $$S_n = \frac{n}{2}[2a_1 + (n - 1)d].$$
- Compare this formula to
- $$S_n = \frac{n}{2}(a_1 + a_n).$$
- Discuss the reasons for the use of one formula over the other. [11.2]
25. It is said that as a young child, the mathematician Karl F. Gauss (1777–1855) was able to compute the sum $1 + 2 + 3 + \dots + 100$ very quickly in his head to the amazement of a teacher. Explain how Gauss might have done this had he possessed some knowledge of arithmetic sequences and series. Then give a formula for the sum of the first n natural numbers. [11.2]
26. Write a problem for a classmate to solve. Devise the problem so that a geometric series is involved and the solution is “The total amount in the bank is $\$900(1.08)^{40}$, or about \$19,552.” [11.3]
27. Write an explanation of the idea behind mathematical induction for a fellow student. [11.4]

Combinatorics: Permutations

11.5

- Evaluate factorial notation and permutation notation and solve related applied problems.

In order to study probability, it is first necessary that we learn about **combinatorics**, the theory of counting.

► Permutations

In this section, we will consider the part of combinatorics called *permutations*.

The study of permutations involves *order* and *arrangements*.

EXAMPLE 1 How many 3-letter code symbols can be formed with the letters A, B, C *without* repetition (that is, using each letter only once)?

Solution Consider placing the letters in these boxes.



We can select any of the 3 letters for the first letter in the symbol. Once this letter has been selected, the second must be selected from the 2 remaining letters. After this, the third letter is already determined, since only 1 possibility is left. That is, we can place any of the 3 letters in the first box, either of the remaining 2 letters in the second box, and the only remaining letter in the third box. The possibilities can be determined using a **tree diagram**, as shown below.

TREE DIAGRAM	OUTCOMES
	ABC
	ACB
	BAC
	BCA
	CAB
	CBA

Each outcome represents one permutation of the letters A, B, C.

We see that there are 6 possibilities. The set of all the possibilities is $\{ABC, ACB, BAC, BCA, CAB, CBA\}$.

This is the set of all *permutations* of the letters A, B, C. 

Suppose that we perform an experiment such as selecting letters (as in the preceding example), flipping a coin, or drawing a card. The results are called **outcomes**. An **event** is a set of outcomes. The following principle enables us to count actions that are combined to form an event.

The Fundamental Counting Principle

Given a combined action, or *event*, in which the first action can be performed in n_1 ways, the second action can be performed in n_2 ways, and so on, the total number of ways in which the combined action can be performed is the product

$$n_1 \cdot n_2 \cdot n_3 \cdot \cdots \cdot n_k.$$

Thus, in Example 1, there are 3 choices for the first letter, 2 for the second letter, and 1 for the third letter, making a total of $3 \cdot 2 \cdot 1$, or 6 possibilities.

EXAMPLE 2 How many 3-letter code symbols can be formed with the letters A, B, C, D, E *with* repetition (that is, allowing letters to be repeated)?

Solution Since repetition is allowed, there are 5 choices for the first letter, 5 choices for the second, and 5 for the third. Thus, by the fundamental counting principle, there are $5 \cdot 5 \cdot 5$, or 125 code symbols. 

Permutation

A **permutation** of a set of n objects is an ordered arrangement of all n objects.

We can use the fundamental counting principle to count the number of permutations of the objects in a set. Consider, for example, a set of 4 objects $\{A, B, C, D\}$.

To find the number of ordered arrangements of the set, we select a first letter: There are 4 choices. Then we select a second letter: There are 3 choices. Then we select a third letter: There are 2 choices. Finally, there is 1 choice for the last selection. Thus, by the fundamental counting principle, there are $4 \cdot 3 \cdot 2 \cdot 1$, or 24, permutations of a set of 4 objects.

We can find a formula for the total number of permutations of all objects in a set of n objects. We have n choices for the first selection, $n - 1$ choices for the second, $n - 2$ for the third, and so on. For the n th selection, there is only 1 choice.

The Total Number of Permutations of n Objects

The total number of permutations of n objects, denoted ${}_nP_n$, is given by

$${}_nP_n = n(n-1)(n-2)\cdots 3\cdot 2\cdot 1.$$

TECHNOLOGY CONNECTION

We can find the total number of permutations of n objects, as in Example 3, using the ${}_nP_r$ operation from the MATH PRB (probability) menu on a graphing calculator.

4	nPr	4	24
7	nPr	7	5040

EXAMPLE 3 Find each of the following.

a) ${}_4P_4$

b) ${}_7P_7$

Solution

Start with 4.

a) ${}_4P_4 = 4 \cdot 3 \cdot 2 \cdot 1 = 24$

4 factors

b) ${}_7P_7 = 7 \cdot 6 \cdot 5 \cdot 4 \cdot 3 \cdot 2 \cdot 1 = 5040$

➔ Now Try Exercise 1.

EXAMPLE 4 In how many ways can 9 packages be placed in 9 mailboxes, one package in a box?

Solution We have

$${}_9P_9 = 9 \cdot 8 \cdot 7 \cdot 6 \cdot 5 \cdot 4 \cdot 3 \cdot 2 \cdot 1 = 362,880.$$

➔ Now Try Exercise 23.

► Factorial Notation

We will use products such as $7 \cdot 6 \cdot 5 \cdot 4 \cdot 3 \cdot 2 \cdot 1$ so often that it is convenient to adopt a notation for them. For the product

$$7 \cdot 6 \cdot 5 \cdot 4 \cdot 3 \cdot 2 \cdot 1,$$

we write $7!$, read “7 factorial.”

We now define factorial notation for natural numbers and for 0.

Factorial Notation

For any natural number n ,

$$n! = n(n-1)(n-2)\cdots 3\cdot 2\cdot 1.$$

For the number 0,

$$0! = 1.$$

We define $0!$ as 1 so that certain formulas can be stated concisely and with a consistent pattern.

TECHNOLOGY CONNECTION

We can evaluate factorial notation using the ! operation from the MATH PRB (probability) menu.

7!	5040
6!	720
5!	120

Here are some examples of factorial notation.

$$7! = 7 \cdot 6 \cdot 5 \cdot 4 \cdot 3 \cdot 2 \cdot 1 = 5040$$

$$6! = 6 \cdot 5 \cdot 4 \cdot 3 \cdot 2 \cdot 1 = 720$$

$$5! = 5 \cdot 4 \cdot 3 \cdot 2 \cdot 1 = 120$$

$$4! = 4 \cdot 3 \cdot 2 \cdot 1 = 24$$

$$3! = 3 \cdot 2 \cdot 1 = 6$$

$$2! = 2 \cdot 1 = 2$$

$$1! = 1 = 1$$

$$0! = 1 = 1$$

We now see that the following statement is true.

$${}_n P_n = n!$$

We will often need to manipulate factorial notation. For example, note that

$$\begin{aligned} 8! &= 8 \cdot 7 \cdot 6 \cdot 5 \cdot 4 \cdot 3 \cdot 2 \cdot 1 \\ &= 8 \cdot (7 \cdot 6 \cdot 5 \cdot 4 \cdot 3 \cdot 2 \cdot 1) = 8 \cdot 7!. \end{aligned}$$

Generalizing, we get the following.

$$\text{For any natural number } n, n! = n(n-1)!$$

By using this result repeatedly, we can further manipulate factorial notation.

EXAMPLE 5 Rewrite 7! with a factor of 5!.

Solution We have

$$7! = 7 \cdot 6! = 7 \cdot 6 \cdot 5!.$$



In general, we have the following.

For any natural numbers k and n , with $k < n$,

$$n! = \underbrace{n(n-1)(n-2) \cdots [n-(k-1)]}_{k \text{ factors}} \cdot \underbrace{(n-k)!}_{n-k \text{ factors}}$$

STUDY TIP

Take time to prepare for class. Review the material that was covered in the previous class and read the portion of the text that will be covered in the next class. When you are prepared, you will be able to follow the lecture more easily and derive the greatest benefit from the time you spend in class.

► Permutations of n Objects Taken k at a Time

Consider a set of 5 objects

$$\{A, B, C, D, E\}.$$

How many ordered arrangements can be formed using 3 objects from the set without repetition? Examples of such an arrangement are EBA, CAB, and BCD. There are 5 choices for the first object, 4 choices for the second, and 3 choices for the third. By the fundamental counting principle, there are

$$5 \cdot 4 \cdot 3, \quad \text{or} \quad 60 \text{ permutations of a set of 5 objects taken 3 at a time.}$$

Note that

$$5 \cdot 4 \cdot 3 = \frac{5 \cdot 4 \cdot 3 \cdot 2 \cdot 1}{2 \cdot 1}, \quad \text{or} \quad \frac{5!}{2!}.$$

Permutation of n Objects Taken k at a Time

A **permutation** of a set of n objects taken k at a time is an ordered arrangement of k objects taken from the set.

Consider a set of n objects and the selection of an ordered arrangement of k of them. There would be n choices for the first object. Then there would remain $n - 1$ choices for the second, $n - 2$ choices for the third, and so on. We make k choices in all, so there are k factors in the product. By the fundamental counting principle, the total number of permutations is

$$\underbrace{n(n-1)(n-2) \cdots [n-(k-1)]}_{k \text{ factors}}.$$

We can express this in another way by multiplying by 1, as follows:

$$\begin{aligned} n(n-1)(n-2) \cdots [n-(k-1)] &\cdot \frac{(n-k)!}{(n-k)!} \\ &= \frac{n(n-1)(n-2) \cdots [n-(k-1)](n-k)!}{(n-k)!} \\ &= \frac{n!}{(n-k)!}. \end{aligned}$$

This gives us the following.

The Number of Permutations of n Objects Taken k at a Time

The number of permutations of a set of n objects taken k at a time, denoted ${}_n P_k$, is given by

$${}_n P_k = \underbrace{n(n-1)(n-2) \cdots [n-(k-1)]}_{k \text{ factors}} \quad (1)$$

$$= \frac{n!}{(n-k)!} \quad (2)$$

TECHNOLOGY CONNECTION

We can evaluate computations like the one in Example 6 using the ${}_nP_r$ operation from the MATH PRB menu on a graphing calculator.

8 nPr 4 1680

EXAMPLE 6 Compute ${}_8P_4$ using both forms of the formula.

Solution Using form (1), we have

$${}_8P_4 = \underbrace{8 \cdot 7 \cdot 6 \cdot 5}_{\text{The 4 tells how many factors.}} = 1680.$$

The 8 tells where to start.

Using form (2), we have

$$\begin{aligned} {}_8P_4 &= \frac{8!}{(8-4)!} \\ &= \frac{8!}{4!} \\ &= \frac{8 \cdot 7 \cdot 6 \cdot 5 \cdot 4!}{4!} = \frac{8 \cdot 7 \cdot 6 \cdot 5 \cdot \cancel{4!}}{\cancel{4!}} \\ &= 8 \cdot 7 \cdot 6 \cdot 5 = 1680. \end{aligned}$$

➔ Now Try Exercise 3.

EXAMPLE 7 *Flags of Nations.* The flags of many nations consist of three horizontal stripes. For example, the flag of the Netherlands, shown here, has its first stripe red, its second white, and its third blue.

Suppose the following 7 colors are available:

{black, yellow, red, white, blue, orange, green}.

How many different flags of three horizontal stripes can be made without repetition of colors in a flag? (This assumes that the order in which the stripes appear is considered.)

Solution We are determining the number of permutations of 7 objects taken 3 at a time. There is no repetition of colors. Using form (1), we get

$${}_7P_3 = 7 \cdot 6 \cdot 5 = 210.$$

➔ Now Try Exercise 37(a).

EXAMPLE 8 *Batting Orders.* A baseball manager arranges the batting order as follows: The 4 infielders will bat first. Then the 3 outfielders, the catcher, and the pitcher will follow, not necessarily in that order. How many different batting orders are possible?

Solution The infielders can bat in ${}_4P_4$ different ways, the rest in ${}_5P_5$ different ways. Then by the fundamental counting principle, we have

$${}_4P_4 \cdot {}_5P_5 = 4! \cdot 5!, \quad \text{or} \quad 2880 \text{ possible batting orders.}$$

➔ Now Try Exercise 31.

If we allow repetition, a situation like the following can occur.

EXAMPLE 9 How many 5-letter code symbols can be formed with the letters A, B, C, and D if we allow a letter to occur more than once?



Solution We can select each of the 5 letters in 4 ways. That is, we can select the first letter in 4 ways, the second in 4 ways, and so on. Thus there are 4^5 , or 1024 arrangements.

➔ **Now Try Exercise 37(b).**

The number of distinct arrangements of n objects taken k at a time, allowing repetition, is n^k .

► Permutations of Sets with Nondistinguishable Objects

Consider a set of 7 marbles, 4 of which are blue and 3 of which are red. When they are lined up, one red marble will look just like any other red marble. In this sense, we say that the red marbles are nondistinguishable and, similarly, the blue marbles are nondistinguishable.



We know that there are $7!$ permutations of this set. Many of them will look alike, however. We develop a formula for finding the number of distinguishable permutations.

Consider a set of n objects in which n_1 are of one kind, n_2 are of a second kind, \dots , and n_k are of a k th kind. The total number of permutations of the set is $n!$, but this includes many that are nondistinguishable. Let N be the total number of distinguishable permutations. For each of these N permutations, there are $n_1!$ actual, nondistinguishable permutations, obtained by permuting the objects of the first kind. For each of these $N \cdot n_1!$ permutations, there are $n_2!$ nondistinguishable permutations, obtained by permuting the objects of the second kind, and so on. By the fundamental counting principle, the total number of permutations, including those that are nondistinguishable, is

$$N \cdot n_1! \cdot n_2! \cdot \cdots \cdot n_k!$$

Then we have $N \cdot n_1! \cdot n_2! \cdot \cdots \cdot n_k! = n!$. Solving for N , we obtain

$$N = \frac{n!}{n_1! \cdot n_2! \cdot \cdots \cdot n_k!}$$

Now, to finish our problem with the marbles, we have

$$\begin{aligned} N &= \frac{7!}{4!3!} \\ &= \frac{7 \cdot 6 \cdot 5 \cdot 4!}{4! \cdot 3 \cdot 2 \cdot 1} = \frac{7 \cdot 3 \cdot 2 \cdot 5 \cdot 4!}{4! \cdot 3 \cdot 2 \cdot 1} \\ &= \frac{7 \cdot 5}{1}, \text{ or } 35 \end{aligned}$$

distinguishable permutations of the marbles.

In general:

For a set of n objects in which n_1 are of one kind, n_2 are of another kind, \dots , and n_k are of a k th kind, the number of distinguishable permutations is

$$\frac{n!}{n_1! \cdot n_2! \cdot \dots \cdot n_k!}$$

EXAMPLE 10 In how many distinguishable ways can the letters of the word CINCINNATI be arranged?

Solution There are 2 C's, 3 I's, 3 N's, 1 A, and 1 T for a total of 10 letters. Thus,

$$N = \frac{10!}{2! \cdot 3! \cdot 3! \cdot 1! \cdot 1!}, \text{ or } 50,400.$$

The letters of the word CINCINNATI can be arranged in 50,400 distinguishable ways.

 **Now Try Exercise 35.**

11.5 Exercise Set

Evaluate.

1. ${}_6P_6$
2. ${}_4P_3$
3. ${}_{10}P_7$
4. ${}_{10}P_3$
5. $5!$
6. $7!$
7. $0!$
8. $1!$
9. $\frac{9!}{5!}$
10. $\frac{9!}{4!}$
11. $(8 - 3)!$
12. $(8 - 5)!$
13. $\frac{10!}{7! 3!}$
14. $\frac{7!}{(7 - 2)!}$
15. ${}_8P_0$
16. ${}_{13}P_1$
17. ${}_{52}P_4$
18. ${}_{52}P_5$
19. ${}_nP_3$
20. ${}_nP_2$
21. ${}_nP_1$
22. ${}_nP_0$

In each of Exercises 23–41, give your answer using permutation notation, factorial notation, or other operations. Then evaluate.

How many permutations are there of the letters in each of the following words, if all the letters are used without repetition?

23. MARVIN
24. JUDY
25. UNDERMOST
26. COMBINES
27. How many permutations are there of the letters of the word UNDERMOST if the letters are taken 4 at a time?
28. How many permutations are there of the letters of the word COMBINES if the letters are taken 5 at a time?
29. How many 5-digit numbers can be formed using the digits 2, 4, 6, 8, and 9 without repetition? with repetition?

30. In how many ways can 7 athletes be arranged in a straight line?
31. **Program Planning.** A program is planned to have 5 musical numbers and 4 speeches. In how many ways can this be done if a musical number and a speech are to alternate and a musical number is to come first?
32. A professor is going to grade her 24 students on a curve. She will give 3 A's, 5 B's, 9 C's, 4 D's, and 3 F's. In how many ways can she do this?
33. **Phone Numbers.** How many 7-digit phone numbers can be formed with the digits 0, 1, 2, 3, 4, 5, 6, 7, 8, and 9, assuming that the first number cannot be 0 or 1? Accordingly, how many telephone numbers can there be within a given area code, before the area needs to be split with a new area code?
34. How many distinguishable code symbols can be formed from the letters of the word BUSINESS? BIOLOGY? MATHEMATICS?
35. Suppose the expression $a^2b^3c^4$ is rewritten without exponents. In how many distinguishable ways can this be done?
36. **Coin Arrangements.** A penny, a nickel, a dime, and a quarter are arranged in a straight line.



- a) Considering just the coins, in how many ways can they be lined up?
- b) Considering the coins and heads and tails, in how many ways can they be lined up?
37. How many code symbols can be formed using 5 out of 6 letters of A, B, C, D, E, F if the letters:
- are not repeated?
 - can be repeated?
 - are not repeated but must begin with D?
 - are not repeated but must begin with DE?

38. **License Plates.** A state forms its license plates by first listing a number that corresponds to the county in which the owner of the car resides. (The names of the counties are alphabetized and the number is its location in that order.) Then the plate lists a letter of the alphabet, and this is followed by a number from 1 to 9999. How many such plates are possible if there are 80 counties?



39. **Zip Codes.** A U.S. postal zip code is a five-digit number.
- How many zip codes are possible if any of the digits 0 to 9 can be used?
 - If each post office has its own zip code, how many possible post offices can there be?
40. **Zip-Plus-4 Codes.** A zip-plus-4 postal code uses a 9-digit number like 75247-5456. How many 9-digit zip-plus-4 postal codes are possible?
41. **Social Security Numbers.** A social security number is a 9-digit number like 243-47-0825.
- How many different social security numbers can there be?
 - There are about 311 million people in the United States. Can each person have a unique social security number?

Skill Maintenance

Find the zero(s) of the function.

42. $f(x) = 4x - 9$
43. $f(x) = x^2 + x - 6$
44. $f(x) = 2x^2 - 3x - 1$
45. $f(x) = x^3 - 4x^2 - 7x + 10$

Synthesis

Solve for n .

$$46. {}_n P_5 = 7 \cdot {}_n P_4 \qquad 47. {}_n P_4 = 8 \cdot {}_{n-1} P_3$$

$$48. {}_n P_5 = 9 \cdot {}_{n-1} P_4 \qquad 49. {}_n P_4 = 8 \cdot {}_n P_3$$

$$50. \text{ Show that } n! = n(n-1)(n-2)(n-3)!$$

51. **Single-Elimination Tournaments.** In a single-elimination sports tournament consisting of n teams, a team is eliminated when it loses one

game. How many games are required to complete the tournament?

52. **Double-Elimination Tournaments.** In a double-elimination softball tournament consisting of n teams, a team is eliminated when it loses two games. At most, how many games are required to complete the tournament?

Combinatorics: Combinations

11.6

► Evaluate combination notation and solve related applied problems.

We now consider counting techniques in which order is not considered.

► Combinations

We sometimes make a selection from a set *without regard to order*. Such a selection is called a *combination*. If you play cards, for example, you know that in most situations the *order* in which you hold cards is not important. That is,

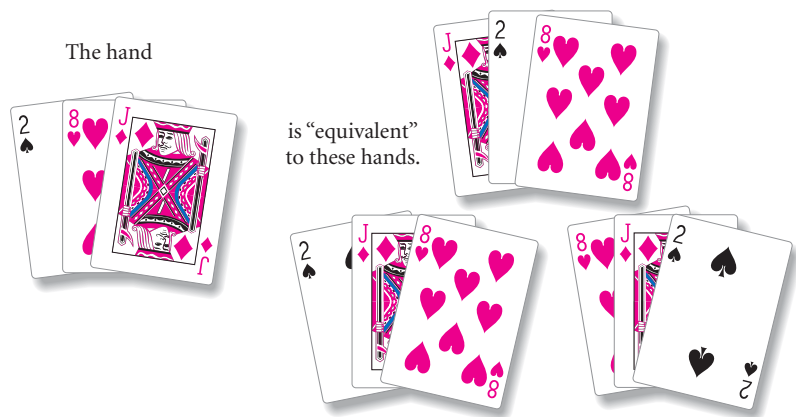

Each hand contains the same combination of three cards.

EXAMPLE 1 Find all the combinations of 3 letters taken from the set of 5 letters $\{A, B, C, D, E\}$.

Solution The combinations are

$$\begin{array}{ll} \{A, B, C\}, & \{A, B, D\}, \\ \{A, B, E\}, & \{A, C, D\}, \\ \{A, C, E\}, & \{A, D, E\}, \\ \{B, C, D\}, & \{B, C, E\}, \\ \{B, D, E\}, & \{C, D, E\}. \end{array}$$

There are 10 combinations of the 5 letters taken 3 at a time. 

When we find all the combinations from a set of 5 objects taken 3 at a time, we are finding all the 3-element subsets. When a set is named, the order of the elements is *not* considered. Thus,

$$\{A, C, B\} \text{ names the same set as } \{A, B, C\}.$$

Combination; Combination Notation

A **combination** containing k objects chosen from a set of n objects, $k \leq n$, is denoted using **combination notation** ${}_n C_k$.

We want to derive a general formula for ${}_n C_k$ for any $k \leq n$. First, it is true that ${}_n C_n = 1$, because a set with n objects has only 1 subset with n objects, the set itself. Second, ${}_n C_1 = n$, because a set with n objects has n subsets with 1 element each. Finally, ${}_n C_0 = 1$, because a set with n objects has only one subset with 0 elements, namely, the empty set \emptyset . To consider other possibilities, let's return to Example 1 and compare the number of combinations with the number of permutations.

COMBINATIONS	PERMUTATIONS
$\{A, B, C\} \rightarrow$	ABC BCA CAB CBA BAC ACB
$\{A, B, D\} \rightarrow$	ABD BDA DAB DBA BAD ADB
$\{A, B, E\} \rightarrow$	ABE BEA EAB EBA BAE AEB
$\{A, C, D\} \rightarrow$	ACD CDA DAC DCA CAD ADC
$\{A, C, E\} \rightarrow$	ACE CEA EAC ECA CAE AEC
$\{A, D, E\} \rightarrow$	ADE DEA EAD EDA DAE AED
$\{B, C, D\} \rightarrow$	BCD CDB DBC DCB CBD BDC
$\{B, C, E\} \rightarrow$	BCE CEB EBC ECB CBE BEC
$\{B, D, E\} \rightarrow$	BDE DEB EBD EDB DBE BED
$\{C, D, E\} \rightarrow$	CDE DEC ECD EDC DCE CED

${}_5 C_3$ of these

}

$3! \cdot {}_5 C_3$ of these

Note that each combination of 3 objects yields 6, or $3!$, permutations:

$$3! \cdot {}_5C_3 = 60 = {}_5P_3 = 5 \cdot 4 \cdot 3,$$

so

$${}_5C_3 = \frac{{}_5P_3}{3!} = \frac{5 \cdot 4 \cdot 3}{3 \cdot 2 \cdot 1} = 10.$$

In general, the number of combinations of n objects taken k at a time, ${}_nC_k$, times the number of permutations of these objects, $k!$, must equal the number of permutations of n objects taken k at a time:

$$\begin{aligned} k! \cdot {}_nC_k &= {}_nP_k \\ {}_nC_k &= \frac{{}_nP_k}{k!} \\ &= \frac{1}{k!} \cdot {}_nP_k \\ &= \frac{1}{k!} \cdot \frac{n!}{(n-k)!} = \frac{n!}{k!(n-k)!}. \end{aligned}$$

Combinations of n Objects Taken k at a Time

The total number of combinations of n objects taken k at a time, denoted ${}_nC_k$, is given by

$${}_nC_k = \frac{n!}{k!(n-k)!}, \quad (1)$$

or

$${}_nC_k = \frac{{}_nP_k}{k!} = \frac{n(n-1)(n-2) \cdots [n-(k-1)]}{k!}. \quad (2)$$

Another kind of notation for ${}_nC_k$ is **binomial coefficient notation**. The reason for such terminology will be seen later.

Binomial Coefficient Notation

$$\binom{n}{k} = {}_nC_k$$

You should be able to use either notation and either form of the formula.

EXAMPLE 2 Evaluate $\binom{7}{5}$, using forms (1) and (2).

Solution

a) By form (1),

$$\begin{aligned}\binom{7}{5} &= \frac{7!}{5!(7-5)!} = \frac{7!}{5!2!} \\ &= \frac{7 \cdot 6 \cdot 5!}{5! \cdot 2!} = \frac{7 \cdot 6 \cdot \cancel{5!}}{\cancel{5!} \cdot 2!} = \frac{7 \cdot 6}{2 \cdot 1} = 21.\end{aligned}$$

b) By form (2),

$$\binom{7}{5} = \frac{7 \cdot 6 \cdot 5 \cdot 4 \cdot 3}{5 \cdot 4 \cdot 3 \cdot 2 \cdot 1} = \frac{7 \cdot 6}{2 \cdot 1} = 21.$$

The 7 tells where to start.

The 5 tells how many factors there are in both the numerator and the denominator and where to start the denominator.

 **Now Try Exercise 11.**

TECHNOLOGY CONNECTION

We can do computations like the one in Example 2 using the ${}_nC_r$ operation from the MATH PRB (probability) menu on a graphing calculator.

7 nCr 5

21

Be sure to keep in mind that $\binom{n}{k}$ does not mean $n \div k$, or n/k .

EXAMPLE 3 Evaluate $\binom{n}{0}$ and $\binom{n}{2}$.

Solution We use form (1) for the first expression and form (2) for the second. Then

$$\binom{n}{0} = \frac{n!}{0!(n-0)!} = \frac{n!}{1 \cdot n!} = 1,$$

using form (1), and

$$\binom{n}{2} = \frac{n(n-1)}{2!} = \frac{n(n-1)}{2}, \quad \text{or} \quad \frac{n^2 - n}{2},$$

using form (2).

 **Now Try Exercise 19.**

Note that

$$\binom{7}{2} = \frac{7 \cdot 6}{2 \cdot 1} = 21.$$

Using the result of Example 2 gives us

$$\binom{7}{5} = \binom{7}{2}.$$

This says that the number of 5-element subsets of a set of 7 objects is the same as the number of 2-element subsets of a set of 7 objects. When 5 elements are chosen from a set, one also chooses *not* to include 2 elements. To see this, consider the set $\{A, B, C, D, E, F, G\}$:

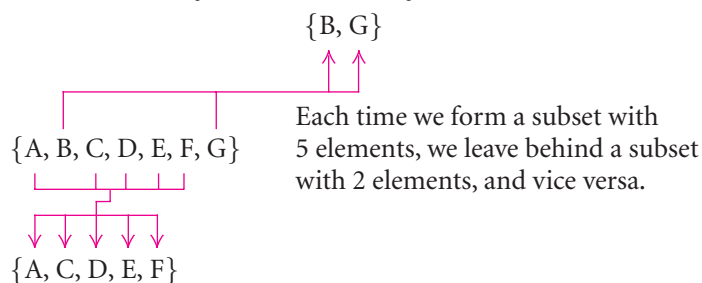

In general, we have the following. This result provides an alternative way to compute combinations.

Subsets of Size k and of Size $n - k$

$$\binom{n}{k} = \binom{n}{n-k} \quad \text{and} \quad {}_n C_k = {}_n C_{n-k}$$

The number of subsets of size k of a set with n objects is the same as the number of subsets of size $n - k$. The number of combinations of n objects taken k at a time is the same as the number of combinations of n objects taken $n - k$ at a time.

We now solve problems involving combinations.

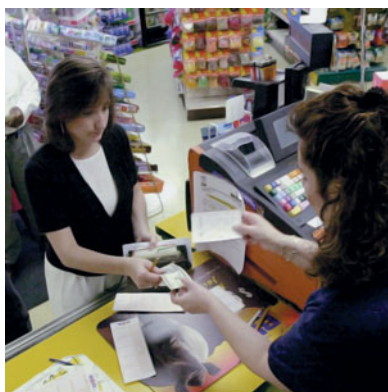

EXAMPLE 4 Michigan Lottery. Run by the state of Michigan, Classic Lotto 47 is a twice-weekly lottery game with jackpots starting at \$1 million. For a wager of \$1, a player can choose 6 numbers from 1 through 47. If the numbers match those drawn by the state, the player wins the jackpot. (Source: www.michigan.gov/lottery)

- How many 6-number combinations are there?
- Suppose it takes you 10 min to pick your numbers and buy a game ticket. How many tickets can you buy in 4 days?
- How many people would you have to hire for 4 days to buy tickets with all the possible combinations and ensure that you win?

Solution

- No order is implied here. You pick any 6 different numbers from 1 through 47. Thus the number of combinations is

$$\begin{aligned} {}_{47}C_6 &= \binom{47}{6} = \frac{47!}{6!(47-6)!} = \frac{47!}{6!41!} \\ &= \frac{47 \cdot 46 \cdot 45 \cdot 44 \cdot 43 \cdot 42}{6 \cdot 5 \cdot 4 \cdot 3 \cdot 2 \cdot 1} = 10,737,573. \end{aligned}$$

b) First we find the number of minutes in 4 days:

$$4 \text{ days} = 4 \text{ days} \cdot \frac{24 \text{ hr}}{1 \text{ day}} \cdot \frac{60 \text{ min}}{1 \text{ hr}} = 5760 \text{ min.}$$

Thus you could buy $5760/10$, or 576 tickets in 4 days.

c) You would need to hire $10,737,573/576$, or about 18,642 people, to buy tickets with all the possible combinations and ensure a win. (This presumes lottery tickets can be bought 24 hours a day.)

 **Now Try Exercise 23.**

EXAMPLE 5 How many committees can be formed from a group of 5 governors and 7 senators if each committee consists of 3 governors and 4 senators?

Solution The 3 governors can be selected in ${}_5C_3$ ways and the 4 senators can be selected in ${}_7C_4$ ways. If we use the fundamental counting principle, it follows that the number of possible committees is

$$\begin{aligned} {}_5C_3 \cdot {}_7C_4 &= \frac{5!}{3!2!} \cdot \frac{7!}{4!3!} \\ &= \frac{5 \cdot 4 \cdot 3!}{3! \cdot 2 \cdot 1} \cdot \frac{7 \cdot 6 \cdot 5 \cdot 4!}{4! \cdot 3 \cdot 2 \cdot 1} \\ &= \frac{5 \cdot 2 \cdot 2 \cdot 3!}{3! \cdot 2 \cdot 1} \cdot \frac{7 \cdot 3 \cdot 2 \cdot 5 \cdot 4!}{4! \cdot 3 \cdot 2 \cdot 1} \\ &= 10 \cdot 35 \\ &= 350. \end{aligned}$$

 **Now Try Exercise 27.**

CONNECTING THE CONCEPTS

Permutations and Combinations

PERMUTATIONS

Permutations involve order and arrangements of objects.

Given 5 books, we can arrange 3 of them on a shelf in ${}_5P_3$, or 60 ways.

Placing the books in different orders produces different arrangements.

COMBINATIONS

Combinations do not involve order or arrangements of objects.

Given 5 books, we can select 3 of them in ${}_5C_3$, or 10 ways.

The order in which the books are chosen does not matter.



11.6

Exercise Set

Evaluate.

1. ${}_{13}C_2$
3. $\binom{13}{11}$
5. $\binom{7}{1}$
7. $\frac{{}_5P_3}{3!}$
9. $\binom{6}{0}$
11. $\binom{6}{2}$
13. $\binom{7}{0} + \binom{7}{1} + \binom{7}{2} + \binom{7}{3} + \binom{7}{4} + \binom{7}{5}$
 $+ \binom{7}{6} + \binom{7}{7}$
14. $\binom{6}{0} + \binom{6}{1} + \binom{6}{2} + \binom{6}{3} + \binom{6}{4}$
 $+ \binom{6}{5} + \binom{6}{6}$
15. ${}_{52}C_4$
17. $\binom{27}{11}$
19. $\binom{n}{1}$
21. $\binom{m}{m}$
2. ${}_9C_6$
4. $\binom{9}{3}$
6. $\binom{8}{8}$
8. $\frac{{}_{10}P_5}{5!}$
10. $\binom{6}{1}$
12. $\binom{6}{3}$
16. ${}_{52}C_5$
18. $\binom{37}{8}$
20. $\binom{n}{3}$
22. $\binom{t}{4}$

In each of the following exercises, give an expression for the answer using permutation notation, combination notation, factorial notation, or other operations. Then evaluate.

23. **Fraternity Officers.** There are 23 students in a fraternity. How many sets of 4 officers can be selected?
24. **League Games.** How many games can be played in a 9-team sports league if each team plays all other teams once? twice?
25. **Test Options.** On a test, a student is to select 10 out of 13 questions. In how many ways can this be done?
26. **Senate Committees.** Suppose the Senate of the United States consists of 58 Democrats and 42 Republicans. How many committees can be formed consisting of 6 Democrats and 4 Republicans?
27. **Test Options.** Of the first 10 questions on a test, a student must answer 7. Of the second 5 questions, the student must answer 3. In how many ways can this be done?
28. **Lines and Triangles from Points.** How many lines are determined by 8 points, no 3 of which are collinear? How many triangles are determined by the same points?
29. **Poker Hands.** How many 5-card poker hands are possible with a 52-card deck?
30. **Bridge Hands.** How many 13-card bridge hands are possible with a 52-card deck?
31. **Baskin-Robbins Ice Cream.** Burt Baskin and Irv Robbins began making ice cream in 1945. Initially they developed 31 flavors—one for each day of the month. (Source: Baskin-Robbins)
 - a) How many 2-dip cones are possible using the 31 original flavors if order of flavors is to be considered and no flavor is repeated?
 - b) How many 2-dip cones are possible if order is to be considered and a flavor can be repeated?
 - c) How many 2-dip cones are possible if order is not considered and no flavor is repeated?



Skill Maintenance

Solve.

$$32. 3x - 7 = 5x + 10$$

$$33. 2x^2 - x = 3$$

$$34. x^2 + 5x + 1 = 0$$

$$35. x^3 + 3x^2 - 10x = 24$$

Synthesis

36. **Full House.** A full house in poker consists of three of a kind and a pair (two of a kind). How many full houses are there that consist of 3 aces and 2 queens? (See Section 8.8 for a description of a 52-card deck.)



37. **Flush.** A flush in poker consists of a 5-card hand with all cards of the same suit. How many 5-card hands (flushes) are there that consist of all diamonds?
38. There are n points on a circle. How many quadrilaterals can be inscribed with these points as vertices?

39. **League Games.** How many games are played in a league with n teams if each team plays each other team once? twice?

Solve for n .

$$40. \binom{n+1}{3} = 2 \cdot \binom{n}{2}$$

$$41. \binom{n}{n-2} = 6$$

$$42. \binom{n}{3} = 2 \cdot \binom{n-1}{2}$$

$$43. \binom{n+2}{4} = 6 \cdot \binom{n}{2}$$

44. Prove that

$$\binom{n}{k-1} + \binom{n}{k} = \binom{n+1}{k}$$

for any natural numbers n and k , $k \leq n$.

45. How many line segments are determined by the n vertices of an n -gon? Of these, how many are diagonals? Use mathematical induction to prove the result for the diagonals.

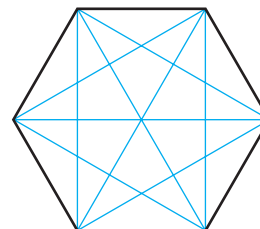

The Binomial Theorem

11.7

- ▶ Expand a power of a binomial using Pascal's triangle or factorial notation.
- ▶ Find a specific term of a binomial expansion.
- ▶ Find the total number of subsets of a set of n objects.

In this section, we consider ways of expanding a binomial $(a + b)^n$.

▶ Binomial Expansions Using Pascal's Triangle

Consider the following expanded powers of $(a + b)^n$, where $a + b$ is any binomial and n is a whole number. Look for patterns.

$$\begin{aligned} (a + b)^0 &= 1 \\ (a + b)^1 &= a + b \\ (a + b)^2 &= a^2 + 2ab + b^2 \\ (a + b)^3 &= a^3 + 3a^2b + 3ab^2 + b^3 \\ (a + b)^4 &= a^4 + 4a^3b + 6a^2b^2 + 4ab^3 + b^4 \\ (a + b)^5 &= a^5 + 5a^4b + 10a^3b^2 + 10a^2b^3 + 5ab^4 + b^5 \end{aligned}$$

Each expansion is a polynomial. There are some patterns to be noted.

1. There is one more term than the power of the exponent, n . That is, there are $n + 1$ terms in the expansion of $(a + b)^n$.
2. In each term, the sum of the exponents is n , the power to which the binomial is raised.
3. The exponents of a start with n , the power of the binomial, and decrease to 0. The last term has no factor of a . The first term has no factor of b , so powers of b start with 0 and increase to n .
4. The coefficients start at 1 and increase through certain values about "half"-way and then decrease through these same values back to 1.

Let's explore the coefficients further. Suppose that we want to find an expansion of $(a + b)^6$. The patterns we just noted indicate that there are 7 terms in the expansion:

$$a^6 + c_1a^5b + c_2a^4b^2 + c_3a^3b^3 + c_4a^2b^4 + c_5ab^5 + b^6.$$

How can we determine the value of each coefficient, c_i ? We can do so in two ways. The first method involves writing the coefficients in a triangular array, as follows. This is known as **Pascal's triangle**:

$$\begin{array}{l} (a + b)^0: \qquad \qquad \qquad 1 \\ (a + b)^1: \qquad \qquad \qquad 1 \quad 1 \\ (a + b)^2: \qquad \qquad \qquad 1 \quad 2 \quad 1 \\ (a + b)^3: \qquad \qquad \qquad 1 \quad 3 \quad 3 \quad 1 \\ (a + b)^4: \qquad \qquad \qquad 1 \quad 4 \quad 6 \quad 4 \quad 1 \\ (a + b)^5: \qquad \qquad \qquad 1 \quad 5 \quad 10 \quad 10 \quad 5 \quad 1 \end{array}$$

There are many patterns in the triangle. Find as many as you can.

Perhaps you discovered a way to write the next row of numbers, given the numbers in the row above it. There are always 1's on the outside. Each remaining number is the sum of the two numbers above it. Let's try to find an expansion for $(a + b)^6$ by adding another row using the patterns we have discovered:

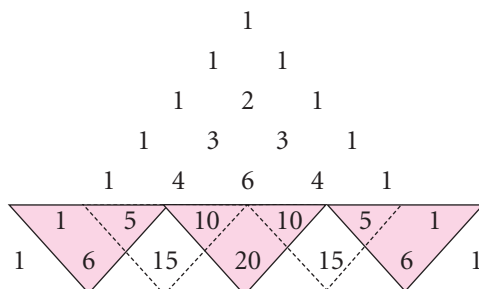

We see that in the last row

- the 1st and last numbers are **1**;
- the 2nd number is $1 + 5$, or **6**;
- the 3rd number is $5 + 10$, or **15**;
- the 4th number is $10 + 10$, or **20**;
- the 5th number is $10 + 5$, or **15**; and
- the 6th number is $5 + 1$, or **6**.

Thus the expansion for $(a + b)^6$ is

$$(a + b)^6 = 1a^6 + 6a^5b + 15a^4b^2 + 20a^3b^3 + 15a^2b^4 + 6ab^5 + 1b^6.$$

To find an expansion for $(a + b)^8$, we complete two more rows of Pascal's triangle:

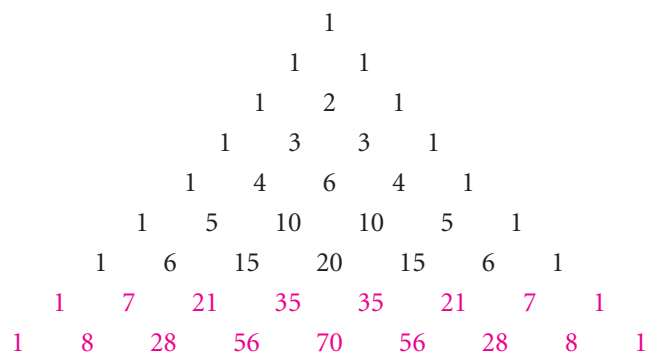

Thus the expansion of $(a + b)^8$ is

$$(a + b)^8 = a^8 + 8a^7b + 28a^6b^2 + 56a^5b^3 + 70a^4b^4 + 56a^3b^5 + 28a^2b^6 + 8ab^7 + b^8.$$

We can generalize our results as follows.

The Binomial Theorem Using Pascal's Triangle

For any binomial $a + b$ and any natural number n ,

$$(a + b)^n = c_0 a^n b^0 + c_1 a^{n-1} b^1 + c_2 a^{n-2} b^2 + \dots \\ + c_{n-1} a^1 b^{n-1} + c_n a^0 b^n,$$

where the numbers $c_0, c_1, c_2, \dots, c_{n-1}, c_n$ are from the $(n + 1)$ st row of Pascal's triangle.

EXAMPLE 1 Expand: $(u - v)^5$.

Solution We have $(a + b)^n$, where $a = u$, $b = -v$, and $n = 5$. We use the 6th row of Pascal's triangle:

$$1 \quad 5 \quad 10 \quad 10 \quad 5 \quad 1$$

Then we have

$$(u - v)^5 = [u + (-v)]^5 \\ = 1(u)^5 + 5(u)^4(-v)^1 + 10(u)^3(-v)^2 + 10(u)^2(-v)^3 \\ + 5(u)(-v)^4 + 1(-v)^5 \\ = u^5 - 5u^4v + 10u^3v^2 - 10u^2v^3 + 5uv^4 - v^5.$$

Note that the signs of the terms alternate between $+$ and $-$. When the power of $-v$ is odd, the sign is $-$.

 **Now Try Exercise 5.**

EXAMPLE 2 Expand: $\left(2t + \frac{3}{t}\right)^4$.

Solution We have $(a + b)^n$, where $a = 2t$, $b = 3/t$, and $n = 4$. We use the 5th row of Pascal's triangle:

$$1 \quad 4 \quad 6 \quad 4 \quad 1$$

Then we have

$$\left(2t + \frac{3}{t}\right)^4 = 1(2t)^4 + 4(2t)^3\left(\frac{3}{t}\right)^1 + 6(2t)^2\left(\frac{3}{t}\right)^2 + 4(2t)^1\left(\frac{3}{t}\right)^3 + 1\left(\frac{3}{t}\right)^4 \\ = 1(16t^4) + 4(8t^3)\left(\frac{3}{t}\right) + 6(4t^2)\left(\frac{9}{t^2}\right) + 4(2t)\left(\frac{27}{t^3}\right) + 1\left(\frac{81}{t^4}\right) \\ = 16t^4 + 96t^2 + 216 + 216t^{-2} + 81t^{-4}.$$

 **Now Try Exercise 9.**

► Binomial Expansion Using Factorial Notation

Suppose that we want to find the expansion of $(a + b)^{11}$. The disadvantage in using Pascal's triangle is that we must compute all the preceding rows of the triangle to obtain the row needed for the expansion. The following method avoids this. It also enables us to find a specific term—say, the 8th term—without computing all the other terms of the expansion. This method is useful in such courses as finite mathematics, calculus, and statistics, and it uses the *binomial coefficient notation* $\binom{n}{k}$ developed in Section 11.6.

We can restate the binomial theorem as follows.

The Binomial Theorem Using Factorial Notation

For any binomial $a + b$ and any natural number n ,

$$\begin{aligned}(a + b)^n &= \binom{n}{0}a^n b^0 + \binom{n}{1}a^{n-1}b^1 + \binom{n}{2}a^{n-2}b^2 + \cdots \\ &\quad + \binom{n}{n-1}a^1 b^{n-1} + \binom{n}{n}a^0 b^n \\ &= \sum_{k=0}^n \binom{n}{k} a^{n-k} b^k.\end{aligned}$$

The binomial theorem can be proved by mathematical induction. (See Exercise 59.) This form shows why $\binom{n}{k}$ is called a *binomial coefficient*.

EXAMPLE 3 Expand: $(x^2 - 2y)^5$.

Solution We have $(a + b)^n$, where $a = x^2$, $b = -2y$, and $n = 5$. Then using the binomial theorem, we have

$$\begin{aligned}(x^2 - 2y)^5 &= \binom{5}{0}(x^2)^5 + \binom{5}{1}(x^2)^4(-2y) + \binom{5}{2}(x^2)^3(-2y)^2 \\ &\quad + \binom{5}{3}(x^2)^2(-2y)^3 + \binom{5}{4}x^2(-2y)^4 + \binom{5}{5}(-2y)^5 \\ &= \frac{5!}{0! 5!}x^{10} + \frac{5!}{1! 4!}x^8(-2y) + \frac{5!}{2! 3!}x^6(4y^2) + \frac{5!}{3! 2!}x^4(-8y^3) \\ &\quad + \frac{5!}{4! 1!}x^2(16y^4) + \frac{5!}{5! 0!}(-32y^5) \\ &= 1 \cdot x^{10} + 5x^8(-2y) + 10x^6(4y^2) + 10x^4(-8y^3) \\ &\quad + 5x^2(16y^4) + 1 \cdot (-32y^5) \\ &= x^{10} - 10x^8y + 40x^6y^2 - 80x^4y^3 + 80x^2y^4 - 32y^5.\end{aligned}$$

 **Now Try Exercise 11.**

EXAMPLE 4 Expand: $\left(\frac{2}{x} + 3\sqrt{x}\right)^4$.

Solution We have $(a + b)^n$, where $a = 2/x$, $b = 3\sqrt{x}$, and $n = 4$. Then using the binomial theorem, we have

$$\begin{aligned} \left(\frac{2}{x} + 3\sqrt{x}\right)^4 &= \binom{4}{0}\left(\frac{2}{x}\right)^4 + \binom{4}{1}\left(\frac{2}{x}\right)^3(3\sqrt{x}) + \binom{4}{2}\left(\frac{2}{x}\right)^2(3\sqrt{x})^2 \\ &\quad + \binom{4}{3}\left(\frac{2}{x}\right)(3\sqrt{x})^3 + \binom{4}{4}(3\sqrt{x})^4 \\ &= \frac{4!}{0!4!}\left(\frac{16}{x^4}\right) + \frac{4!}{1!3!}\left(\frac{8}{x^3}\right)(3x^{1/2}) \\ &\quad + \frac{4!}{2!2!}\left(\frac{4}{x^2}\right)(9x) + \frac{4!}{3!1!}\left(\frac{2}{x}\right)(27x^{3/2}) \\ &\quad + \frac{4!}{4!0!}(81x^2) \\ &= \frac{16}{x^4} + \frac{96}{x^{5/2}} + \frac{216}{x} + 216x^{1/2} + 81x^2. \end{aligned}$$

 **Now Try Exercise 13.**

► Finding a Specific Term

Suppose that we want to determine only a particular term of an expansion. The method we have developed will allow us to find such a term without computing all the rows of Pascal's triangle or all the preceding coefficients.

Note that in the binomial theorem, $\binom{n}{0}a^n b^0$ gives us the 1st term, $\binom{n}{1}a^{n-1}b^1$ gives us the 2nd term, $\binom{n}{2}a^{n-2}b^2$ gives us the 3rd term, and so on. This can be generalized as follows.

Finding the $(k + 1)$ st Term

The $(k + 1)$ st term of $(a + b)^n$ is $\binom{n}{k}a^{n-k}b^k$.

EXAMPLE 5 Find the 5th term in the expansion of $(2x - 5y)^6$.

Solution First, we note that $5 = 4 + 1$. Thus, $k = 4$, $a = 2x$, $b = -5y$, and $n = 6$. Then the 5th term of the expansion is

$$\binom{6}{4}(2x)^{6-4}(-5y)^4, \quad \text{or} \quad \frac{6!}{4!2!}(2x)^2(-5y)^4, \quad \text{or} \quad 37,500x^2y^4.$$

 **Now Try Exercise 21.**

EXAMPLE 6 Find the 8th term in the expansion of $(3x - 2)^{10}$.

Solution First, we note that $8 = 7 + 1$. Thus, $k = 7$, $a = 3x$, $b = -2$, and $n = 10$. Then the 8th term of the expansion is

$$\binom{10}{7}(3x)^{10-7}(-2)^7, \quad \text{or} \quad \frac{10!}{7!3!}(3x)^3(-2)^7, \quad \text{or} \quad -414,720x^3.$$

 **Now Try Exercise 25.**

► Total Number of Subsets

Suppose that a set has n objects. The number of subsets containing k elements is $\binom{n}{k}$ by a result of Section 11.6. The total number of subsets of a set is the number of subsets with 0 elements, plus the number of subsets with 1 element, plus the number of subsets with 2 elements, and so on. The total number of subsets of a set with n elements is

$$\binom{n}{0} + \binom{n}{1} + \binom{n}{2} + \cdots + \binom{n}{n}.$$

Now consider the expansion of $(1 + 1)^n$:

$$\begin{aligned} (1 + 1)^n &= \binom{n}{0} \cdot 1^n + \binom{n}{1} \cdot 1^{n-1} \cdot 1^1 + \binom{n}{2} \cdot 1^{n-2} \cdot 1^2 \\ &\quad + \cdots + \binom{n}{n} \cdot 1^n \\ &= \binom{n}{0} + \binom{n}{1} + \binom{n}{2} + \cdots + \binom{n}{n}. \end{aligned}$$

Thus the total number of subsets is $(1 + 1)^n$, or 2^n . We have proved the following.

Total Number of Subsets

The total number of subsets of a set with n elements is 2^n .

EXAMPLE 7 The set $\{A, B, C, D, E\}$ has how many subsets?

Solution The set has 5 elements, so the number of subsets is 2^5 , or 32.

 **Now Try Exercise 31.**

EXAMPLE 8 Wendy's, a national restaurant chain, offers the following toppings for its hamburgers:

{catsup, mustard, mayonnaise, tomato, lettuce, onions, pickle}.

How many different kinds of hamburgers can Wendy's serve, excluding size of hamburger or number of patties?

Solution The toppings on each hamburger are the elements of a subset of the set of all possible toppings, the empty set being a plain hamburger. The total number of possible hamburgers is

$$\binom{7}{0} + \binom{7}{1} + \binom{7}{2} + \cdots + \binom{7}{7} = 2^7 = 128.$$

Thus Wendy's serves hamburgers in 128 different ways.

 **Now Try Exercise 33.**

11.7 Exercise Set

Expand.

1. $(x + 5)^4$
2. $(x - 1)^4$
3. $(x - 3)^5$
4. $(x + 2)^9$
5. $(x - y)^5$
6. $(x + y)^8$
7. $(5x + 4y)^6$
8. $(2x - 3y)^5$
9. $\left(2t + \frac{1}{t}\right)^7$
10. $\left(3y - \frac{1}{y}\right)^4$
11. $(x^2 - 1)^5$
12. $(1 + 2q^3)^8$
13. $(\sqrt{5} + t)^6$
14. $(x - \sqrt{2})^6$
15. $\left(a - \frac{2}{a}\right)^9$
16. $(1 + 3)^n$
17. $(\sqrt{2} + 1)^6 - (\sqrt{2} - 1)^6$
18. $(1 - \sqrt{2})^4 + (1 + \sqrt{2})^4$
19. $(x^{-2} + x^2)^4$
20. $\left(\frac{1}{\sqrt{x}} - \sqrt{x}\right)^6$

Find the indicated term of the binomial expansion.

21. 3rd; $(a + b)^7$
22. 6th; $(x + y)^8$
23. 6th; $(x - y)^{10}$
24. 5th; $(p - 2q)^9$
25. 12th; $(a - 2)^{14}$
26. 11th; $(x - 3)^{12}$
27. 5th; $(2x^3 - \sqrt{y})^8$
28. 4th; $\left(\frac{1}{b^2} + \frac{b}{3}\right)^7$

29. Middle; $(2u - 3v^2)^{10}$

30. Middle two; $(\sqrt{x} + \sqrt{3})^5$

Determine the number of subsets of each of the following.

31. A set of 7 elements
32. A set of 6 members
33. The set of letters of the Greek alphabet, which contains 24 letters
34. The set of letters of the English alphabet, which contains 26 letters
35. What is the degree of $(x^5 + 3)^4$?
36. What is the degree of $(2 - 5x^3)^7$?

Expand each of the following, where $i^2 = -1$.

37. $(3 + i)^5$
38. $(1 + i)^6$
39. $(\sqrt{2} - i)^4$
40. $\left(\frac{\sqrt{3}}{2} - \frac{1}{2}i\right)^{11}$
41. Find a formula for $(a - b)^n$. Use sigma notation.

42. Expand and simplify:

$$\frac{(x + h)^{13} - x^{13}}{h}.$$

43. Expand and simplify:

$$\frac{(x + h)^n - x^n}{h}.$$

Use sigma notation.

Skill Maintenance

Given that $f(x) = x^2 + 1$ and $g(x) = 2x - 3$, find each of the following.

44. $(f + g)(x)$

45. $(fg)(x)$

46. $(f \circ g)(x)$

47. $(g \circ f)(x)$

Synthesis

Solve for x .

48. $\sum_{k=0}^8 \binom{8}{k} x^{8-k} 3^k = 0$

49. $\sum_{k=0}^4 \binom{4}{k} (-1)^k x^{4-k} 6^k = 81$

50. Find the term of

$$\left(\frac{3x^2}{2} - \frac{1}{3x} \right)^{12}$$

that does not contain x .

51. Find the middle term of $(x^2 - 6y^{3/2})^6$.

52. Find the ratio of the 4th term of

$$\left(p^2 - \frac{1}{2} p \sqrt[3]{q} \right)^5$$

to the 3rd term.

53. Find the term of

$$\left(\sqrt[3]{x} - \frac{1}{\sqrt{x}} \right)^7$$

containing $1/x^{1/6}$.

54. **Money Combinations.** A money clip contains one each of the following bills: \$1, \$2, \$5, \$10, \$20, \$50, and \$100. How many different sums of money can be formed using the bills?

Find the sum.

55. ${}_{100}C_0 + {}_{100}C_1 + \cdots + {}_{100}C_{100}$

56. ${}_nC_0 + {}_nC_1 + \cdots + {}_nC_n$

Simplify.

57. $\sum_{k=0}^{23} \binom{23}{k} (\log_a x)^{23-k} (\log_a t)^k$

58. $\sum_{k=0}^{15} \binom{15}{k} i^{30-2k}$

59. Use mathematical induction and the property

$$\binom{n}{r-1} + \binom{n}{r} = \binom{n+1}{r}$$

to prove the binomial theorem.

Probability

11.8

► Compute the probability of a simple event.

When a coin is tossed, we can reason that the chance, or likelihood, that it will fall heads is 1 out of 2, or the **probability** that it will fall heads is $\frac{1}{2}$. Of course, this does not mean that if a coin is tossed 10 times it will necessarily fall heads 5 times. If the coin is a “fair coin” and it is tossed a great many

times, however, it will fall heads very nearly half of the time. Here we give an introduction to two kinds of probability, **experimental** and **theoretical**.

■ STUDY TIP

It is always best to study for a final exam over a period of at least two weeks. If you have only one or two days of study time, however, begin by reviewing each chapter, studying the formulas, theorems, properties, and procedures in the sections and in the Study Guide in the Chapter Summary and Review. Then do the exercises in each Chapter Summary and Review and in the Chapter Test. Also, attend a review session if one is available.

► Experimental and Theoretical Probability

If we toss a coin a great number of times—say, 1000—and count the number of times it falls heads, we can determine the probability that it will fall heads. If it falls heads 503 times, we would calculate the probability of its falling heads to be

$$\frac{503}{1000}, \text{ or } 0.503.$$

This is an **experimental** determination of probability. Such a determination of probability is discovered by the observation and study of data and is quite common and very useful. Here, for example, are some probabilities that have been determined *experimentally*:

1. The probability that a woman will get breast cancer in her lifetime is $\frac{1}{11}$.
2. If you kiss someone who has a cold, the probability of your catching a cold is 0.07.
3. A person who has just been released from prison has an 80% probability of returning.

If we consider a coin and reason that it is just as likely to fall heads as tails, we would calculate the probability that it will fall heads to be $\frac{1}{2}$. This is a **theoretical** determination of probability. Here are some other probabilities that have been determined *theoretically*, using mathematics:

1. If there are 30 people in a room, the probability that two of them have the same birthday (excluding year) is 0.706.
2. While on a trip, you meet someone and, after a period of conversation, discover that you have a common acquaintance. The typical reaction, “It’s a small world!”, is actually not appropriate, because the probability of such an occurrence is quite high—just over 22%.

In summary, experimental probabilities are determined by making observations and gathering data. Theoretical probabilities are determined by reasoning mathematically. Examples of experimental and theoretical probability like those above, especially those we do not expect, lead us to see the value of a study of probability. You might ask, “What is the *true* probability?” In fact, there is none. Experimentally, we can determine probabilities within certain limits. These may or may not agree with the probabilities that we obtain theoretically. There are situations in which it is much easier to determine one of these types of probabilities than the other. For example, it would be quite difficult to arrive at the probability of catching a cold using theoretical probability.

► Computing Experimental Probabilities

We first consider experimental determination of probability. The basic principle we use in computing such probabilities is as follows.

Principle P (Experimental)

Given an experiment in which n observations are made, if a situation, or event, E occurs m times out of n observations, then we say that the **experimental probability** of the event, $P(E)$, is given by

$$P(E) = \frac{m}{n}.$$

EXAMPLE 1 *Television Ratings.* There are an estimated 114,900,000 households in the United States that have at least one television. Each week, viewing information is collected and reported. One week 19,400,000 households tuned in to the 2010 World Cup soccer match between the United States and Ghana on ABC and Univision, and 9,700,000 households tuned in to the action series “NCIS” on CBS (*Source: Nielsen Media Research*). What is the probability that a television household tuned in to the soccer match during the given week? to “NCIS”?



Solution The probability that a television household was tuned in to the soccer match is P , where

$$P = \frac{19,400,000}{114,900,000} \approx 0.169 \approx 16.9\%.$$

The probability that a television household was tuned in to “NCIS” is P , where

$$P = \frac{9,700,000}{114,900,000} \approx 0.084 \approx 8.4\%.$$

Now Try Exercise 1.

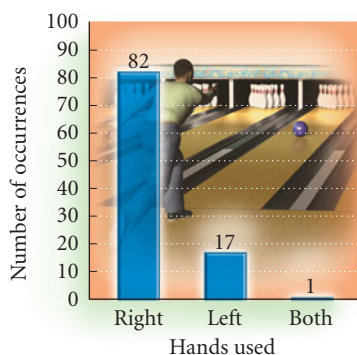

EXAMPLE 2 *Sociological Survey.* The authors of this text conducted an experimental survey to determine the number of people who are left-handed, right-handed, or both. The results are shown in the graph at left.

- Determine the probability that a person is right-handed.
- Determine the probability that a person is left-handed.
- Determine the probability that a person is ambidextrous (uses both hands with equal ability).
- There are 120 bowlers in most tournaments held by the Professional Bowlers Association. On the basis of the data in this experiment, how many of the bowlers would you expect to be left-handed?

Solution

- a) The number of people who are right-handed is 82, the number who are left-handed is 17, and the number who are ambidextrous is 1. The total number of observations is $82 + 17 + 1$, or 100. Thus the probability that a person is right-handed is P , where

$$P = \frac{82}{100}, \text{ or } 0.82, \text{ or } 82\%.$$

- b) The probability that a person is left-handed is P , where

$$P = \frac{17}{100}, \text{ or } 0.17, \text{ or } 17\%.$$

- c) The probability that a person is ambidextrous is P , where

$$P = \frac{1}{100}, \text{ or } 0.01, \text{ or } 1\%.$$

- d) There are 120 bowlers, and from part (b) we can expect 17% to be left-handed. Since

$$17\% \text{ of } 120 = 0.17 \cdot 120 = 20.4,$$

we can expect that about 20 of the bowlers will be left-handed.

➔ Now Try Exercise 3.

► Theoretical Probability

Suppose that we perform an experiment such as flipping a coin, throwing a dart, drawing a card from a deck, or checking an item off an assembly line for quality. Each possible result of such an experiment is called an **outcome**. The set of all possible outcomes is called the **sample space**. An **event** is a set of outcomes, that is, a subset of the sample space.

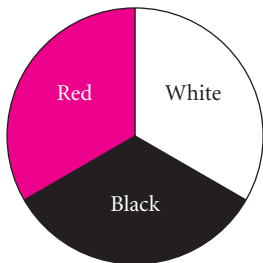

EXAMPLE 3 Dart Throwing. Consider the dartboard at left. Assume that the experiment is “throwing a dart” and that the dart hits the board. Find each of the following.

- a) The outcomes b) The sample space

Solution

- a) The outcomes are *hitting black* (B), *hitting red* (R), and *hitting white* (W).
 b) The sample space is $\{\textit{hitting black}, \textit{hitting red}, \textit{hitting white}\}$, which can be simply stated as $\{B, R, W\}$. ➔

EXAMPLE 4 Die Rolling. A die (pl., dice) is a cube, with six faces, each containing a number of dots from 1 to 6 on each side.

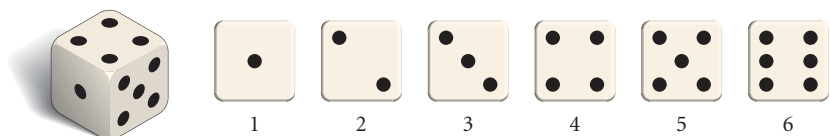

Suppose a die is rolled. Find each of the following.

- a) The outcomes b) The sample space

Solution

- a) The outcomes are 1, 2, 3, 4, 5, 6.
 b) The sample space is $\{1, 2, 3, 4, 5, 6\}$.



We denote the probability that an event E occurs as $P(E)$. For example, “a coin falling heads” may be denoted H . Then $P(H)$ represents the probability of the coin falling heads. When all the outcomes of an experiment have the same probability of occurring, we say that they are *equally likely*. To see the distinction between events that are equally likely and those that are not, consider the dartboards shown below.

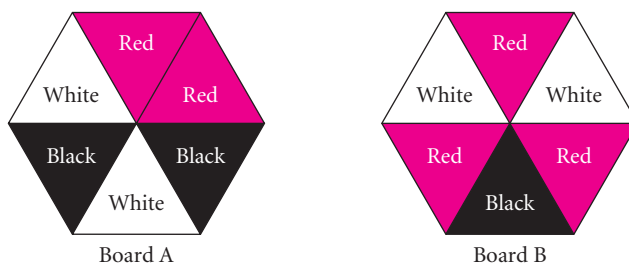

For board A, the events *hitting black*, *hitting red*, and *hitting white* are equally likely, because the black, red, and white areas are the same. However, for board B the areas are not the same so these events are not equally likely.

Principle P (Theoretical)

If an event E can occur m ways out of n possible equally likely outcomes of a sample space S , then the **theoretical probability** of the event, $P(E)$, is given by

$$P(E) = \frac{m}{n}.$$

EXAMPLE 5 Suppose that we select, without looking, one marble from a bag containing 3 red marbles and 4 green marbles. What is the probability of selecting a red marble?

Solution There are 7 equally likely ways of selecting any marble, and since the number of ways of getting a red marble is 3, we have

$$P(\text{selecting a red marble}) = \frac{3}{7}.$$

Now Try Exercise 5(a).

EXAMPLE 6 What is the probability of rolling an even number on a die?

Solution The event is rolling an *even* number. It can occur 3 ways (rolling 2, 4, or 6). The number of equally likely outcomes is 6. By Principle *P*,

$$P(\text{even}) = \frac{3}{6}, \quad \text{or} \quad \frac{1}{2}.$$

➔ Now Try Exercise 7.

We will use a number of examples related to a standard bridge deck of 52 cards. Such a deck is made up as shown in the following figure.

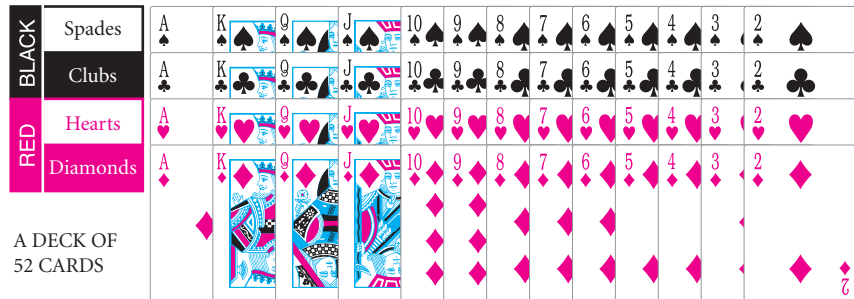

EXAMPLE 7 What is the probability of drawing an ace from a well-shuffled deck of cards?

Solution There are 52 outcomes (the number of cards in the deck), they are equally likely (from a well-shuffled deck), and there are 4 ways to obtain an ace, so by Principle *P*, we have

$$P(\text{drawing an ace}) = \frac{4}{52}, \quad \text{or} \quad \frac{1}{13}.$$

➔ Now Try Exercise 9(a).

The following are some results that follow from Principle *P*.

Probability Properties

- If an event E cannot occur, then $P(E) = 0$.
- If an event E is certain to occur, then $P(E) = 1$.
- The probability that an event E will occur is a number from 0 to 1: $0 \leq P(E) \leq 1$.

For example, in coin tossing, the event that a coin will land on its edge has probability 0. The event that a coin falls either heads or tails has probability 1.

In the following examples, we use the combinatorics that we studied in Sections 11.5 and 11.6 to calculate theoretical probabilities.

EXAMPLE 8 Suppose that 2 cards are drawn from a well-shuffled deck of 52 cards. What is the probability that both of them are spades?

Solution The number of ways n of drawing 2 cards from a well-shuffled deck of 52 cards is ${}_{52}C_2$. Since 13 of the 52 cards are spades, the number of ways m of drawing 2 spades is ${}_{13}C_2$. Thus,

$$P(\text{drawing 2 spades}) = \frac{m}{n} = \frac{{}_{13}C_2}{{}_{52}C_2} = \frac{78}{1326} = \frac{1}{17}.$$

 **Now Try Exercise 11.**

TECHNOLOGY CONNECTION

We can use the ${}_nC_r$ operation from the MATH PRB menu and the \blacktriangleright Frac operation from the MATH MATH menu to compute the probabilities in Examples 8 and 9 on a graphing calculator.

13 nCr 2/52 nCr 2▶Frac
1/17

6 nCr 1*4 nCr 2/10 nCr
3▶Frac
3/10

EXAMPLE 9 Suppose that 3 people are selected at random from a group that consists of 6 men and 4 women. What is the probability that 1 man and 2 women are selected?

Solution The number of ways of selecting 3 people from a group of 10 is ${}_{10}C_3$. One man can be selected in ${}_6C_1$ ways, and 2 women can be selected in ${}_4C_2$ ways. By the fundamental counting principle, the number of ways of selecting 1 man and 2 women is ${}_6C_1 \cdot {}_4C_2$. Thus the probability that 1 man and 2 women are selected is

$$P = \frac{{}_6C_1 \cdot {}_4C_2}{{}_{10}C_3} = \frac{3}{10}.$$

 **Now Try Exercise 13.**

EXAMPLE 10 *Rolling Two Dice.* What is the probability of getting a total of 8 on a roll of a pair of dice?

Solution On each die, there are 6 possible outcomes. The outcomes are paired so there are $6 \cdot 6$, or 36, possible ways in which the two can fall. (Assuming that the dice are different—say, one red and one blue—can help in visualizing this.)

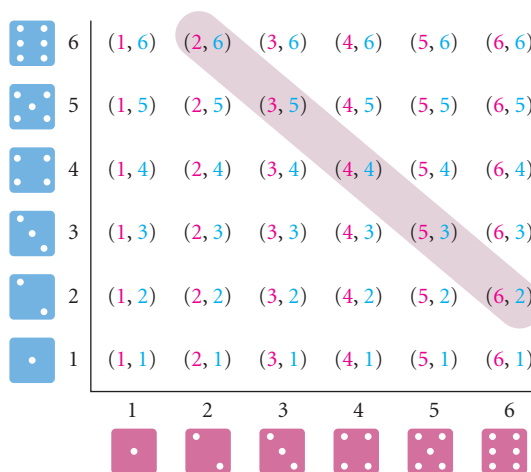

The pairs that total 8 are as shown in the figure above. There are 5 possible ways of getting a total of 8, so the probability is $\frac{5}{36}$.

 **Now Try Exercise 19.**

11.8

Exercise Set

1. **Select a Number.** In a survey conducted by the authors, 100 people were polled and asked to select a number from 1 to 5. The results are shown in the following table.

Number Chosen	1	2	3	4	5
Number Who Chose That Number	18	24	23	23	12

- a) What is the probability that the number chosen is 1? 2? 3? 4? 5?
 b) What general conclusion might be made from the results of the experiment?

2. **Mason Dots®.** Made by the Tootsie Industries of Chicago, Illinois, Mason Dots® is a gumdrop candy. A box was opened by the authors and was found to contain the following number of gumdrops:

Orange	9
Lemon	8
Strawberry	7
Grape	6
Lime	5
Cherry	4

If we take one gumdrop out of the box, what is the probability of getting lemon? lime? orange? grape? strawberry? licorice?

3. **Junk Mail.** In experimental studies, the U.S. Postal Service has found that the probability that a piece of advertising is opened and read is 78%. A business sends out 15,000 pieces of advertising. How many of these can the company expect to be opened and read?
 4. **Linguistics.** An experiment was conducted by the authors to determine the relative occurrence of various letters of the English alphabet. The front page of a newspaper was considered. In all, there

were 9136 letters. The number of occurrences of each letter of the alphabet is listed in the following table.

Letter	Number of Occurrences	Probability
A	853	853/9136 \approx 9.3%
B	136	
C	273	
D	286	
E	1229	
F	173	
G	190	
H	399	
I	539	
J	21	
K	57	
L	417	
M	231	
N	597	
O	705	
P	238	
Q	4	
R	609	
S	745	
T	789	
U	240	
V	113	
W	127	
X	20	
Y	124	
Z	21	21/9136 \approx 0.2%

- a) Complete the table of probabilities with the percentage, to the nearest tenth of a percent, of the occurrence of each letter.
 b) What is the probability of a vowel occurring?
 c) What is the probability of a consonant occurring?
 5. **Marbles.** Suppose that we select, without looking, one marble from a bag containing 4 red marbles and

10 green marbles. What is the probability of selecting each of the following?

- A red marble
- A green marble
- A purple marble
- A red marble or a green marble

6. **Selecting Coins.** Suppose that we select, without looking, one coin from a bag containing 5 pennies, 3 dimes, and 7 quarters. What is the probability of selecting each of the following?

- A dime
- A quarter
- A nickel
- A penny, a dime, or a quarter

7. **Rolling a Die.** What is the probability of rolling a number less than 4 on a die?

8. **Rolling a Die.** What is the probability of rolling either a 1 or a 6 on a die?

9. **Drawing a Card.** Suppose that a card is drawn from a well-shuffled deck of 52 cards. What is the probability of drawing each of the following?

- A queen
- An ace or a 10
- A heart
- A black 6

10. **Drawing a Card.** Suppose that a card is drawn from a well-shuffled deck of 52 cards. What is the probability of drawing each of the following?

- A 7
- A jack or a king
- A black ace
- A red card

11. **Drawing Cards.** Suppose that 3 cards are drawn from a well-shuffled deck of 52 cards. What is the probability that they are all aces?

12. **Drawing Cards.** Suppose that 4 cards are drawn from a well-shuffled deck of 52 cards. What is the probability that they are all red?

13. **Production Unit.** The sales force of a business consists of 10 men and 10 women. A production unit of 4 people is set up at random. What is the probability that 2 men and 2 women are chosen?

14. **Coin Drawing.** A sack contains 7 dimes, 5 nickels, and 10 quarters. Eight coins are drawn at random.

What is the probability of getting 4 dimes, 3 nickels, and 1 quarter?

Five-Card Poker Hands. Suppose that 5 cards are drawn from a deck of 52 cards. What is the probability of drawing each of the following?

15. 3 sevens and 2 kings

16. 5 aces

17. 5 spades

18. 4 aces and 1 five

19. **Tossing Three Coins.** Three coins are flipped. An outcome might be HTH.

a) Find the sample space.

What is the probability of getting each of the following?

b) Exactly one head

c) At most two tails

d) At least one head

e) Exactly two tails

Roulette. An American roulette wheel contains 38 slots numbered 00, 0, 1, 2, 3, . . . , 35, 36. Eighteen of the slots numbered 1–36 are colored red and 18 are colored black. The 00 and 0 slots are considered to be uncolored. The wheel is spun, and a ball is rolled around the rim until it falls into a slot. What is the probability that the ball falls in each of the following?



20. A red slot

21. A black slot

22. The 00 slot

23. The 0 slot

24. Either the 00 or the 0 slot

25. A red slot or a black slot

26. The number 24
27. An odd-numbered slot
28. **Dartboard.** The figure below shows a dartboard. A dart is thrown and hits the board. Find the probabilities
 $P(\text{red})$, $P(\text{green})$, $P(\text{blue})$, $P(\text{yellow})$.

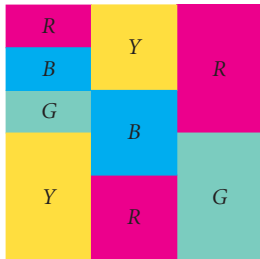

Skill Maintenance

In each of Exercises 29–36, fill in the blank with the correct term. Some of the given choices will be used more than once. Others will not be used.

range
 domain
 function
 an inverse function
 a composite function
 direct variation
 inverse variation
 factor
 solution
 zero
 y -intercept
 one-to-one
 rational
 permutation
 combination
 arithmetic sequence
 geometric sequence

29. $A(n)$ _____ of a function is an input for which the output is 0.
30. A function is _____ if different inputs have different outputs.
31. $A(n)$ _____ is a correspondence between a first set, called the _____, and a second set, called the _____, such that each member of the _____ corresponds to exactly one member of the _____.

32. The first coordinate of an x -intercept of a function is $a(n)$ _____ of the function.
33. A selection made from a set without regard to order is a(n) _____.
34. If we have a function $f(x) = k/x$, where k is a positive constant, we have _____.
35. For a polynomial function $f(x)$, if $f(c) = 0$, then $x - c$ is a(n) _____ of the polynomial.
36. We have $\frac{a_{n+1}}{a_n} = r$, for any integer $n \geq 1$, in a(n) _____.

Synthesis

Five-Card Poker Hands. Suppose that 5 cards are drawn from a deck of 52 cards. For the following exercises, give both a reasoned expression and an answer.

37. **Two Pairs.** A hand with two pairs is a hand like Q-Q-3-3-A.
 a) How many are there?
 b) What is the probability of getting two pairs?
38. **Full House.** A full house consists of 3 of a kind and a pair such as Q-Q-Q-4-4.
 a) How many full houses are there?
 b) What is the probability of getting a full house?
39. **Three of a Kind.** A three-of-a-kind is a 5-card hand in which exactly 3 of the cards are of the same denomination and the other 2 are not a pair, such as Q-Q-Q-10-7.
 a) How many three-of-a-kind hands are there?
 b) What is the probability of getting three of a kind?
40. **Four of a Kind.** A four-of-a-kind is a 5-card hand in which 4 of the cards are of the same denomination, such as J-J-J-J-6, 7-7-7-7-A, or 2-2-2-2-5.
 a) How many four-of-a-kind hands are there?
 b) What is the probability of getting four of a kind?

Chapter 11 Summary and Review

STUDY GUIDE

KEY TERMS AND CONCEPTS

EXAMPLES

SECTION 11.1: SEQUENCES AND SERIES

An **infinite sequence** is a function having for its domain the set of positive integers $\{1, 2, 3, 4, 5, \dots\}$.

A **finite sequence** is a function having for its domain a set of positive integers $\{1, 2, 3, 4, 5, \dots, n\}$ for some positive integer n .

The sum of the terms of an infinite sequence is an **infinite series**. A **partial sum** is the sum of the first n terms. It is also called a **finite series** or the **n th partial sum** and is denoted S_n .

A sequence can be defined **recursively** by listing the first term, or the first few terms, and then using a **recursion formula** to determine the remaining terms from the given term.

The first four terms of the sequence whose general term is given by $a_n = 3n + 2$ are

$$a_1 = 3 \cdot 1 + 2 = 5,$$

$$a_2 = 3 \cdot 2 + 2 = 8,$$

$$a_3 = 3 \cdot 3 + 2 = 11, \text{ and}$$

$$a_4 = 3 \cdot 4 + 2 = 14.$$

For the sequence above, $S_4 = 5 + 8 + 11 + 14$, or 38.

We can denote this sum using **sigma notation** as

$$\sum_{k=1}^4 (3k + 2).$$

The first four terms of the recursively defined sequence

$$a_1 = 3, \quad a_{n+1} = (a_n - 1)^2$$

are

$$a_1 = 3,$$

$$a_2 = (a_1 - 1)^2 = (3 - 1)^2 = 4,$$

$$a_3 = (a_2 - 1)^2 = (4 - 1)^2 = 9, \text{ and}$$

$$a_4 = (a_3 - 1)^2 = (9 - 1)^2 = 64.$$

SECTION 11.2: ARITHMETIC SEQUENCES AND SERIES

For an arithmetic sequence:

$$a_{n+1} = a_n + d;$$

d is the common difference.

$$a_n = a_1 + (n - 1)d;$$

The n th term

$$S_n = \frac{n}{2}(a_1 + a_n).$$

The sum of the first n terms

For the arithmetic sequence 5, 8, 11, 14, ... :

$$a_1 = 5;$$

$$d = 3 \quad (8 - 5 = 3, 11 - 8 = 3, \text{ and so on});$$

$$a_6 = 5 + (6 - 1)3 = 5 + 15 = 20;$$

$$S_6 = \frac{6}{2}(5 + 20) = 3(25) = 75.$$

SECTION 11.3: GEOMETRIC SEQUENCES AND SERIES

For a geometric sequence:

$$a_{n+1} = a_n r$$

$$a_n = a_1 r^{n-1};$$

$$S_n = \frac{a(1 - r^n)}{1 - r};$$

$$S_\infty = \frac{a_1}{1 - r}, \quad |r| < 1.$$

r is the common ratio.

The n th term

The sum of the first n terms

The limit, or sum, of an infinite geometric series

For the geometric sequence $12, -6, 3, -\frac{3}{2}, \dots$:

$$a_1 = 12;$$

$$r = -\frac{1}{2} \quad \left(\frac{-6}{12} = -\frac{1}{2}, \frac{3}{-6} = -\frac{1}{2}, \text{ and so on} \right);$$

$$a_6 = 12 \left(-\frac{1}{2} \right)^{6-1} = 12 \left(-\frac{1}{2^5} \right) = -\frac{3}{8};$$

$$S_6 = \frac{12 \left[1 - \left(-\frac{1}{2} \right)^6 \right]}{1 - \left(-\frac{1}{2} \right)} = \frac{12 \left(1 - \frac{1}{64} \right)}{\frac{3}{2}} = \frac{63}{8};$$

$$|r| = \left| -\frac{1}{2} \right| = \frac{1}{2} < 1, \text{ so we have}$$

$$S_\infty = \frac{12}{1 - \left(-\frac{1}{2} \right)} = \frac{12}{\frac{3}{2}} = 8.$$

SECTION 11.4: MATHEMATICAL INDUCTION

The Principle of Mathematical Induction

We can prove an infinite sequence of statements S_n by showing the following.

- (1) *Basic step.* S_1 is true.
- (2) *Induction step.* For all natural numbers k , $S_k \rightarrow S_{k+1}$.

See Examples 1–3 on pp. 941–943.

SECTION 11.5: COMBINATORICS: PERMUTATIONS

The Fundamental Counting Principle

Given a combined action, or *event*, in which the first action can be performed in n_1 ways, the second action can be performed in n_2 ways, and so on, the total number of ways in which the combined action can be performed is the product

$$n_1 \cdot n_2 \cdot n_3 \cdots n_k.$$

The product $n(n-1)(n-2) \cdots 3 \cdot 2 \cdot 1$, for any natural number n , can also be written in **factorial notation** as $n!$. For the number 0, $0! = 1$.

The total number of permutations, or ordered arrangements, of n objects, denoted ${}_n P_n$, is given by

$${}_n P_n = n(n-1)(n-2) \cdots 3 \cdot 2 \cdot 1, \quad \text{or} \quad n!.$$

In how many ways can 7 books be arranged in a straight line?

We have

$${}_7 P_7 = 7! = 7 \cdot 6 \cdot 5 \cdot 4 \cdot 3 \cdot 2 \cdot 1 = 5040.$$

The Number of Permutations of n Objects Taken k at a Time

$${}_n P_k = n(n-1)(n-2)\cdots[n-(k-1)] \quad (1)$$

$$= \frac{n!}{(n-k)!} \quad (2)$$

The number of distinct arrangements of n objects taken k at a time, allowing repetition, is n^k .

For a set of n objects in which n_1 are of one kind, n_2 are of another kind, \dots , and n_k are of a k th kind, the number of distinguishable permutations is

$$\frac{n!}{n_1! \cdot n_2! \cdot \cdots \cdot n_k!}$$

Compute ${}_7 P_4$.

Using form (1), we have

$${}_7 P_4 = 7 \cdot 6 \cdot 5 \cdot 4 = 840.$$

Using form (2), we have

$$\begin{aligned} {}_7 P_4 &= \frac{7!}{(7-4)!} = \frac{7 \cdot 6 \cdot 5 \cdot 4 \cdot 3!}{3!} \\ &= \frac{7 \cdot 6 \cdot 5 \cdot 4 \cdot \cancel{3!}}{\cancel{3!}} = 840. \end{aligned}$$

The number of 4-number code symbols that can be formed with the numbers 5, 6, 7, 8, and 9, if we allow a number to occur more than once, is 5^4 , or 625.

Find the number of distinguishable code symbols that can be formed using the letters in the word MISSISSIPPI.

There are 1 M, 4 I's, 4 S's, and 2 P's, for a total of 11 letters, so we have

$$\frac{11!}{1! 4! 4! 2!}, \text{ or } 34,650.$$

SECTION 11.6: COMBINATORICS: COMBINATIONS
The Number of Combinations of n Objects Taken k at a Time

$${}_n C_k = \frac{n!}{k!(n-k)!} \quad (1)$$

$$= \frac{{}_n P_k}{k!}$$

$$= \frac{n(n-1)(n-2)\cdots[n-(k-1)]}{k!} \quad (2)$$

We can also use **binomial coefficient notation**:

$$\binom{n}{k} = {}_n C_k.$$

Compute: $\binom{6}{4}$, or ${}_6 C_4$.

Using form (1), we have

$$\begin{aligned} \binom{6}{4} &= \frac{6!}{4!(6-4)!} = \frac{6!}{4! 2!} \\ &= \frac{6 \cdot 5 \cdot 4!}{4! 2!} = \frac{6 \cdot 5 \cdot \cancel{4!}}{\cancel{4!} \cdot 2 \cdot 1} = 15. \end{aligned}$$

Using form (2), we have

$$\binom{6}{4} = \frac{{}_6 P_4}{4!} = \frac{6 \cdot 5 \cdot 4 \cdot 3}{4 \cdot 3 \cdot 2 \cdot 1} = 15.$$

SECTION 11.7: THE BINOMIAL THEOREM
The Binomial Theorem Using Pascal's Triangle

For any binomial $a + b$ and any natural number n ,

$$(a+b)^n = c_0 a^n b^0 + c_1 a^{n-1} b^1 + c_2 a^{n-2} b^2 + \cdots + c_{n-1} a^1 b^{n-1} + c_n a^0 b^n,$$

where the numbers $c_0, c_1, c_2, \dots, c_{n-1}, c_n$ are from the $(n+1)$ st row of Pascal's triangle. (See Pascal's triangle on p. 965.)

Expand: $(x-2)^4$.

We have $a = x$, $b = -2$, and $n = 4$. We use the fourth row of Pascal's triangle.

$$\begin{aligned} (x-2)^4 &= 1 \cdot x^4 + 4 \cdot x^3(-2)^1 + 6 \cdot x^2(-2)^2 + 4 \cdot x^1(-2)^3 + 1(-2)^4 \\ &= x^4 + 4x^3(-2) + 6x^2 \cdot 4 + 4x(-8) + 16 \\ &= x^4 - 8x^3 + 24x^2 - 32x + 16 \end{aligned}$$

The Binomial Theorem Using Factorial Notation

For any binomial $a + b$ and any natural number n ,

$$\begin{aligned}(a + b)^n &= \binom{n}{0}a^n b^0 + \binom{n}{1}a^{n-1}b^1 \\ &\quad + \binom{n}{2}a^{n-2}b^2 + \dots \\ &\quad + \binom{n}{n-1}a^1 b^{n-1} + \binom{n}{n}a^0 b^n \\ &= \sum_{k=0}^n \binom{n}{k} a^{n-k} b^k.\end{aligned}$$

The $(k + 1)$ st term of $(a + b)^n$ is $\binom{n}{k} a^{n-k} b^k$.

The **total number of subsets** of a set with n elements is 2^n .

Expand: $(x^2 + 3)^3$.

We have $a = x^2$, $b = 3$, and $n = 3$.

$$\begin{aligned}(x^2 + 3)^3 &= \binom{3}{0}(x^2)^3 + \binom{3}{1}(x^2)^2(3) \\ &\quad + \binom{3}{2}(x^2)3^2 + \binom{3}{3}3^3 \\ &= \frac{3!}{0!3!}x^6 + \frac{3!}{1!2!}(x^4)(3) + \frac{3!}{2!1!}(x^2)(9) \\ &\quad + \frac{3!}{3!0!}(27) \\ &= 1 \cdot x^6 + 3 \cdot 3x^4 + 3 \cdot 9x^2 + 1 \cdot 27 \\ &= x^6 + 9x^4 + 27x^2 + 27\end{aligned}$$

The third term of $(x^2 + 3)^3$ is

$$\binom{3}{2}(x^2)^{3-2} \cdot 3^2 = 3 \cdot x^2 \cdot 9 = 27x^2. \quad (k = 2)$$

How many subsets does the set $\{W, X, Y, Z\}$ have?

The set has 4 elements, so we have

$$2^4, \text{ or } 16.$$

SECTION 11.8: PROBABILITY**Principle P (Experimental)**

Given an experiment in which n observations are made, if a situation, or event, E occurs m times out of n observations, then we say that the **experimental probability** of the event, $P(E)$, is given by

$$P(E) = \frac{m}{n}.$$

Principle P (Theoretical)

If an event E can occur m ways out of n possible equally likely outcomes of a sample space S , then the **theoretical probability** of the event, $P(E)$, is given by

$$P(E) = \frac{m}{n}.$$

From a batch of 1000 gears, 35 were found to be defective. The probability that a defective gear is produced is

$$\frac{35}{1000} = 0.035, \text{ or } 3.5\%.$$

What is the probability of drawing 2 red marbles and 1 green marble from a bag containing 5 red marbles, 6 green marbles, and 4 white marbles?

Number of ways of drawing 3 marbles from a bag of 15: ${}_{15}C_3$

Number of ways of drawing 2 red marbles from 5 red marbles: ${}_5C_2$

Number of ways of drawing 1 green marble from 6 green marbles: ${}_6C_1$

Probability that 2 red marbles and 1 green marble are drawn:

$$\frac{{}_5C_2 \cdot {}_6C_1}{{}_{15}C_3} = \frac{10 \cdot 6}{455} = \frac{12}{91}$$

REVIEW EXERCISES

Determine whether the statement is true or false.

1. A sequence is a function. [11.1]
2. An infinite geometric series with $r = -1$ has a limit. [11.3]
3. Permutations involve order and arrangements of objects. [11.5]
4. The total number of subsets of a set with n elements is n^2 . [11.7]
5. Find the first 4 terms, a_{11} , and a_{23} :

$$a_n = (-1)^n \left(\frac{n^2}{n^4 + 1} \right). \quad [11.1]$$

6. Predict the general, or n th, term. Answers may vary.
2, -5, 10, -17, 26, ... [11.1]
7. Find and evaluate:

$$\sum_{k=1}^4 \frac{(-1)^{k+1} 3^k}{3^k - 1}. \quad [11.1]$$

8. Write sigma notation. Answers may vary.
 $0 + 3 + 8 + 15 + 24 + 35 + 48$ [11.1]
9. Find the 10th term of the arithmetic sequence
 $\frac{3}{4}, \frac{13}{12}, \frac{17}{12}, \dots$ [11.2]
10. Find the 6th term of the arithmetic sequence
 $a - b, a, a + b, \dots$ [11.2]

11. Find the sum of the first 18 terms of the arithmetic sequence
4, 7, 10, ... [11.2]

12. Find the sum of the first 200 natural numbers. [11.2]

13. The 1st term in an arithmetic sequence is 5, and the 17th term is 53. Find the 3rd term. [11.2]

14. The common difference in an arithmetic sequence is 3. The 10th term is 23. Find the first term. [11.2]

15. For a geometric sequence, $a_1 = -2$, $r = 2$, and $a_n = -64$. Find n and S_n . [11.3]

16. For a geometric sequence, $r = \frac{1}{2}$ and $S_5 = \frac{31}{2}$. Find a_1 and a_5 . [11.3]

Find the sum of each infinite geometric series, if it exists. [11.3]

$$17. 25 + 27.5 + 30.25 + 33.275 + \dots$$

$$18. 0.27 + 0.0027 + 0.000027 + \dots$$

$$19. \frac{1}{2} - \frac{1}{6} + \frac{1}{18} - \dots$$

20. Find fraction notation for $2.\overline{43}$. [11.3]

21. Insert four arithmetic means between 5 and 9. [11.2]

22. **Bouncing Golfball.** A golfball is dropped to the pavement from a height of 30 ft. It always rebounds three-fourths of the distance that it drops. How far (up and down) will the ball have traveled when it hits the pavement for the 6th time? [11.3]

23. **The Amount of an Annuity.** To create a college fund, a parent makes a sequence of 18 yearly deposits of \$2000 each in a savings account on which interest is compounded annually at 2.8%. Find the amount of the annuity. [11.3]

24. **Total Gift.** Suppose you receive 10¢ on the first day of the year, 12¢ on the 2nd day, 14¢ on the 3rd day, and so on.

- a) How much will you receive on the 365th day? [11.2]
- b) What is the sum of these 365 gifts? [11.2]

25. **The Economic Multiplier.** Suppose the government is making a \$24,000,000,000 expenditure for travel to Mars. If 73% of this amount is spent again, and so on, what is the total effect on the economy? [11.3]

Use mathematical induction to prove each of the following. [11.4]

26. For every natural number n ,

$$1 + 4 + 7 + \dots + (3n - 2) = \frac{n(3n - 1)}{2}.$$

27. For every natural number n ,

$$1 + 3 + 3^2 + \dots + 3^{n-1} = \frac{3^n - 1}{2}.$$

28. For every natural number $n \geq 2$,

$$\left(1 - \frac{1}{2}\right)\left(1 - \frac{1}{3}\right)\dots\left(1 - \frac{1}{n}\right) = \frac{1}{n}.$$

29. **Book Arrangements.** In how many ways can 6 books be arranged on a shelf? [11.5]
30. **Flag Displays.** If 9 different signal flags are available, how many different displays are possible using 4 flags in a row? [11.5]

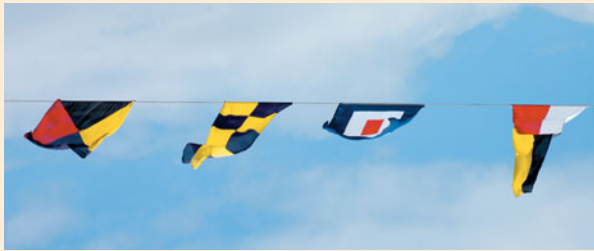

31. **Prize Choices.** The winner of a contest can choose any 8 of 15 prizes. How many different sets of prizes can be chosen? [11.6]
32. **Fraternity–Sorority Names.** The Greek alphabet contains 24 letters. How many fraternity or sorority names can be formed using 3 different letters? [11.5]
33. **Letter Arrangements.** In how many distinguishable ways can the letters of the word TENNESSEE be arranged? [11.5]
34. **Floor Plans.** A manufacturer of houses has 1 floor plan but achieves variety by having 3 different roofs, 4 different ways of attaching the garage, and 3 different types of entrances. Find the number of different houses that can be produced. [11.5]
35. **Code Symbols.** How many code symbols can be formed using 5 out of 6 of the letters of G, H, I, J, K, L if the letters:
- cannot be repeated? [11.5]
 - can be repeated? [11.5]
 - cannot be repeated but must begin with K? [11.5]
 - cannot be repeated but must end with IGH? [11.5]
36. Determine the number of subsets of a set containing 8 members. [11.7]
37. $(m + n)^7$
38. $(x - \sqrt{2})^5$
39. $(x^2 - 3y)^4$
40. $\left(a + \frac{1}{a}\right)^8$
41. $(1 + 5i)^6$, where $i^2 = -1$
42. Find the 4th term of $(a + x)^{12}$. [11.7]
43. Find the 12th term of $(2a - b)^{18}$. Do not multiply out the factorials. [11.7]
44. **Rolling Dice.** What is the probability of getting a 10 on a roll of a pair of dice? on a roll of 1 die? [11.8]
45. **Drawing a Card.** From a deck of 52 cards, 1 card is drawn at random. What is the probability that it is a club? [11.8]
46. **Drawing Three Cards.** From a deck of 52 cards, 3 are drawn at random without replacement. What is the probability that 2 are aces and 1 is a king? [11.8]
47. **Election Poll.** Three people were running for mayor in an election campaign. A poll was conducted to see which candidate was favored. During the polling, 86 favored candidate A, 97 favored B, and 23 favored C. Assuming that the poll is a valid indicator of the election results, what is the probability that the election will be won by A? B? C? [11.8]
48. Which of the following is the 25th term of the arithmetic sequence 12, 10, 8, 6, ...? [11.2]
- 38
 - 36
 - 32
 - 60
49. What is the probability of getting a total of 4 on a roll of a pair of dice? [11.8]
- $\frac{1}{12}$
 - $\frac{1}{9}$
 - $\frac{1}{6}$
 - $\frac{5}{36}$
50. The graph of the sequence whose general term is $a_n = n - 1$ is which of the following? [11.1]

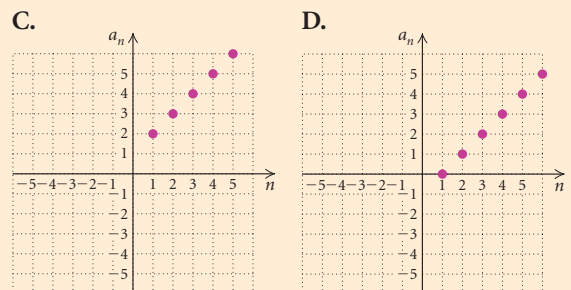
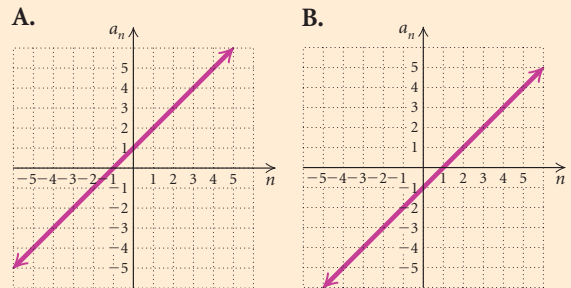

Expand. [11.7]

37. $(m + n)^7$

38. $(x - \sqrt{2})^5$

39. $(x^2 - 3y)^4$

40. $\left(a + \frac{1}{a}\right)^8$

41. $(1 + 5i)^6$, where $i^2 = -1$

Synthesis

51. Explain why the following cannot be proved by mathematical induction: For every natural number n ,
- a) $3 + 5 + \dots + (2n + 1) = (n + 1)^2$. [11.4]
 b) $1 + 3 + \dots + (2n - 1) = n^2 + 3$. [11.4]
52. Suppose that a_1, a_2, \dots, a_n and b_1, b_2, \dots, b_n are geometric sequences. Prove that c_1, c_2, \dots, c_n is a geometric sequence, where $c_n = a_n b_n$. [11.3]
53. Suppose that a_1, a_2, \dots, a_n is an arithmetic sequence. Is b_1, b_2, \dots, b_n an arithmetic sequence if:
- a) $b_n = |a_n|$? [11.2] b) $b_n = a_n + 8$? [11.2]
 c) $b_n = 7a_n$? [11.2] d) $b_n = \frac{1}{a_n}$? [11.2]
 e) $b_n = \log a_n$? [11.2] f) $b_n = a_n^3$? [11.2]
54. The zeros of this polynomial function form an arithmetic sequence. Find them. [11.2]

$$f(x) = x^4 - 4x^3 - 4x^2 + 16x$$

55. Write the first 3 terms of the infinite geometric series with $r = -\frac{1}{3}$ and $S_\infty = \frac{3}{8}$. [11.3]
56. Simplify:

$$\sum_{k=0}^{10} (-1)^k \binom{10}{k} (\log x)^{10-k} (\log y)^k. \quad [11.6]$$

Solve for n . [11.6]

$$57. \binom{n}{6} = 3 \cdot \binom{n-1}{5} \quad 58. \binom{n}{n-1} = 36$$

59. Solve for a :

$$\sum_{k=0}^5 \binom{5}{k} 9^{5-k} a^k = 0. \quad [11.7]$$

Collaborative Discussion and Writing

60. How “long” is 15? Suppose you own 15 books and decide to make up all the possible arrangements of the books on a shelf. About how long, in years, would it take you if you were to make one arrangement per second? Write out the reasoning you used for this problem in the form of a paragraph. [11.5]
61. *Circular Arrangements.* In how many ways can the numbers on a clock face be arranged? See if you can derive a formula for the number of distinct circular arrangements of n objects. Explain your reasoning. [11.5]
62. Give an explanation that you might use with a fellow student to explain that

$$\binom{n}{k} = \binom{n}{n-k}. \quad [11.6]$$

63. Explain why a “combination” lock should really be called a “permutation” lock. [11.6]
64. Discuss the advantages and disadvantages of each method of finding a binomial expansion. Give examples of when you might use one method rather than the other. [11.7]

Chapter 11 Test

1. For the sequence whose n th term is $a_n = (-1)^n(2n + 1)$, find a_{21} .
2. Find the first 5 terms of the sequence with general term

$$a_n = \frac{n+1}{n+2}$$

3. Find and evaluate:

$$\sum_{k=1}^4 (k^2 + 1).$$

Write sigma notation. Answers may vary.

4. $4 + 8 + 12 + 16 + 20 + 24$

5. $2 + 4 + 8 + 16 + 32 + \dots$

6. Find the first 4 terms of the recursively defined sequence

$$a_1 = 3, \quad a_{n+1} = 2 + \frac{1}{a_n}$$

7. Find the 15th term of the arithmetic sequence $2, 5, 8, \dots$

8. The 1st term of an arithmetic sequence is 8 and the 21st term is 108. Find the 7th term.
9. Find the sum of the first 20 terms of the series $17 + 13 + 9 + \dots$.
10. Find the sum: $\sum_{k=1}^{25} (2k + 1)$.
11. Find the 11th term of the geometric sequence $10, -5, \frac{5}{2}, -\frac{5}{4}, \dots$.
12. For a geometric sequence, $r = 0.2$ and $S_4 = 1248$. Find a_1 .

Find the sum, if it exists.

13. $\sum_{k=1}^8 2^k$
14. $18 + 6 + 2 + \dots$
15. Find fraction notation for $0.\overline{56}$.
16. **Salvage Value.** The value of an office machine is \$10,000. Its salvage value each year is 80% of its value the year before. Give a sequence that lists the salvage value of the machine for each year of a 6-yr period.
17. **Hourly Wage.** Tamika accepts a job, starting with an hourly wage of \$8.50, and is promised a raise of 25¢ per hour every three months for 4 yr. What will Tamika's hourly wage be at the end of the 4-yr period?
18. **Amount of an Annuity.** To create a college fund, a parent makes a sequence of 18 equal yearly deposits of \$2500 in a savings account on which interest is compounded annually at 5.6%. Find the amount of the annuity.

19. Use mathematical induction to prove that, for every natural number n ,

$$2 + 5 + 8 + \dots + (3n - 1) = \frac{n(3n + 1)}{2}$$

Evaluate.

20. ${}_{15}P_6$ 21. ${}_{21}C_{10}$ 22. $\binom{n}{4}$

23. How many 4-digit numbers can be formed using the digits 1, 3, 5, 6, 7, and 9 without repetition?
24. How many code symbols can be formed using 4 of the 6 letters A, B, C, X, Y, Z if the letters:
- can be repeated?
 - are not repeated and must begin with Z?

25. **Scuba Club Officers.** The Bay Woods Scuba Club has 28 members. How many sets of 4 officers can be selected from this group?

26. **Test Options.** On a test with 20 questions, a student must answer 8 of the first 12 questions and 4 of the last 8. In how many ways can this be done?

27. Expand: $(x + 1)^5$.

28. Find the 5th term of the binomial expansion $(x - y)^7$.

29. Determine the number of subsets of a set containing 9 members.

30. **Marbles.** Suppose that we select, without looking, one marble from a bag containing 6 red marbles and 8 blue marbles. What is the probability of selecting a blue marble?

31. **Drawing Coins.** Ethan has 6 pennies, 5 dimes, and 4 quarters in his pocket. Six coins are drawn at random. What is the probability of getting 1 penny, 2 dimes, and 3 quarters?

32. The graph of the sequence whose general term is $a_n = 2n - 2$ is which of the following?

A.

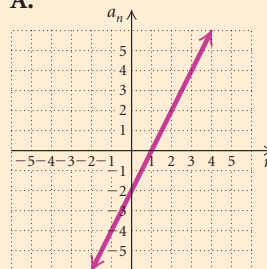

B.

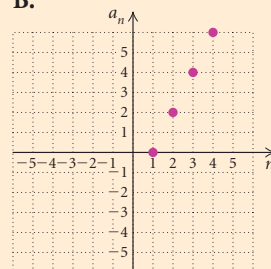

C.

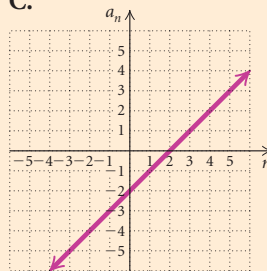

D.

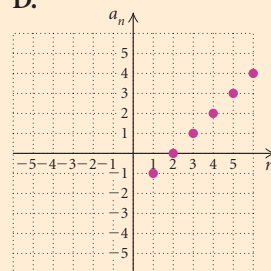

Synthesis

33. Solve for n : ${}_nP_7 = 9 \cdot {}_nP_6$.

Photo Credits

p. 1: (clockwise from left) Phovoir/Jupiter Images; Yellowdog Productions/Jupiter Images; Bob Pardue/MyLoupe Stock Images **p. 11:** Neil Guegan/Jupiter Images **p. 15:** (left) Phovoir/Jupiter Images (right) Greg Pease/Photographer's Choice/Getty Images **p. 16:** Lucas Tiedge/IT Stock Free/Jupiter Images **p. 59:** (clockwise from left) Julien Muguét/IP3/Newscom; Tezzstock/Shutterstock; Shutterstock **p. 66:** Jim Lipschutz/Shutterstock **p. 76:** Monkey Business Images/Shutterstock **p. 77:** AP Images **p. 78:** Hans Keryk/Reuters/Landov **p. 85:** Kyodo/Landov **p. 90:** (top) Johnny Habell/Shutterstock (bottom) Maksym Gorpenyuk/Shutterstock **p. 97:** (top) Andy Clark/Reuters/Landov (bottom) Newphotoservice/Shutterstock **p. 98:** Chris Terry/Jamie Oliver's Food Revolution/Newscom **p. 99:** Darryl Dyck/AP Images **p. 101:** Iofoto/Shutterstock **p. 104:** (top) Brad Whitsitt/Shutterstock (bottom) David Hughes/Shutterstock **p. 105:** Ant Clausen/Shutterstock **p. 115:** UPI/Kevin Dietsch/Newscom **p. 120:** (left) Photodisc/Thinkstock (right) Comstock/Thinkstock **p. 125:** Jeffrey Hamilton/Thinkstock **p. 126:** Noel Hendrickson/Digital Vision/Thinkstock **p. 129:** Shutterstock **p. 130:** Bikeriderlondon/Shutterstock **p. 134:** Daniel Ochoa De Olza/AFP/Getty Images **p. 135:** Creatas Images/Thinkstock **p. 136:** (left) Maridav/Shutterstock (right) The Indiana Stadium and Convention Building Authority **p. 137:** (top) Marcio Jose Bastos Silva/Shutterstock (bottom) Julien Muguét/IP3/Newscom **p. 141:** Joy Brown/Shutterstock **p. 142:** Christina Richards/Shutterstock **p. 152:** Tom Brakefield/Jupiter Images **p. 153:** Robyn Mackenzie/iStockphoto **p. 157:** (clockwise from left) Perkus/Shutterstock; Psamtik/Shutterstock; iStockphoto **p. 167:** Susan Quinland/Shutterstock **p. 168:** Corbis **p. 179:** Shutterstock **p. 186:** (left) Jim Barber/Shutterstock (right) Rihardzz/Shutterstock **p. 189:** (clockwise from top left) Clearviewstock/Alamy; Dimitry Atanasov/Shutterstock; Corbis/SuperStock; SuperStock RF/SuperStock; Corbis Premium RF/Alamy **p. 198:** (clockwise from top left) M.M.G./Shutterstock; Shutterstock; Reed Kaestner/Corbis; Gary718/Shutterstock; Pedro Salaverría/Shutterstock **p. 209:** All Canada Photos/SuperStock **p. 212:** Vladimir Gramagin/Shutterstock **p. 214:** Crisferra/Dreamstime **p. 216:** WellyWelly/Shutterstock **p. 217:** Brendan Hoffman/Getty Images **p. 218:** Perkus/Shutterstock **p. 233:** (clockwise from left) Big Cheese Photo LLC/Alamy; iStockphoto; iStockphoto **p. 250:** Typhoonski/Dreamstime **p. 255:** (left) iStockphoto (right) Atalu/Dreamstime **p. 265:** Juan Carlos Zamora/Shutterstock **p. 269:** Andresr/Shutterstock **p. 295:** (clockwise from left) AZP Worldwide/Alamy; Feverpitch/Shutterstock; Boguslaw

Mazur/Shutterstock p. 307: (top) Galina Barskaya/Shutterstock (bottom) Joseph Sohm-Visions of America/Photodisc/Getty Images p. 308: Boguslaw Mazur/Shutterstock p. 355: Jamie Wilson/Shutterstock p. 387: (clockwise from left) Mb2006/Dreamstime; Canettisto/Dreamstime; Richard B. Levine/Newscom p. 399: (left) Ingram Publishing/Jupiter Images (right) Fuse/Jupiter Images p. 410: Suzye/Dreamstime p. 411: (top left) MDD/Shutterstock (bottom left) Awe-Inspiring Images/Shutterstock (right) George Doyle/Thinkstock p. 412: Racheal Grazias/Shutterstock p. 424: lde/Newscom p. 427: John A. Rizzo/Thinkstock p. 428: Thinkstock Images p. 455: Lucie Batkova/Shutterstock p. 458: Kristyna Wentz-Graff/Milwaukee Journal Sentinel/PSG/Newscom p. 459: (left) SaraJo/Shutterstock (right) James Steidl/Shutterstock p. 460: Steve Healy/The Star p. 461: (left) Supreme Council of Antiquities/AP Images (right) DCW Creations/Shutterstock p. 462: (left) Oleksiy Maksymenko/Alamy (top right) Joe Raedle/Getty Images (bottom right) Stan Honda/AFP/Getty Images p. 463: Denis Tabler/Shutterstock p. 464: Jeffrey M. Frank/Shutterstock p. 473: Lucy Hornby/Reuters/Landov p. 477: (all three photos) Icy Straight Point p. 483: National Geographic/Getty Images p. 486: Susan Law Cain/Shutterstock p. 492: Albert Cheng/Shutterstock p. 494: Eric Limon/Shutterstock p. 495: Zhu Difeng/Shutterstock p. 496: Cheryl Casey/Shutterstock p. 497: Ffooter/Shutterstock p. 499: Icy Straight Point p. 500: CuboImages SRL/Alamy p. 501: Mumbojumbo/Shutterstock p. 517: Richair/Dreamstime p. 529: (left) Copyright © 2006 The Children's Museum of Indianapolis (right) Mark Burnett/Alamy p. 534: Courtesy of Goss Graphics Systems p. 562: Gerrit/Shutterstock p. 568: Mana Photo/Shutterstock p. 579: John Brueske/Shutterstock p. 583: (clockwise from left) Trevor Smithers ARPS/Alamy; Esa Hiltula/Alamy; Simone Voigt/Shutterstock p. 596: Imagebroker.net/SuperStock p. 637: (left) Trevor Smithers ARPS/Alamy (right) Thomas Northcut/Photodisc/Jupiter Images p. 649: (clockwise from left) Jorg Hackemann/Shutterstock; RCPPhoto/Shutterstock; SACarroll/Shutterstock p. 654: Donald R. Swartz/Shutterstock p. 660: David P. Smith/Shutterstock p. 661: John Brueske/Shutterstock p. 666: Yuri Arcurs/Shutterstock p. 737: (clockwise from left) Tony Pitts/Alamy; Jack Hollingsworth/Jupiter Images; Mary Bingham/Shutterstock p. 751: (top) Ipatov/Shutterstock (bottom) Ami Chappell/Reuters/Landov p. 752: Kzenon/Shutterstock p. 760: (top) Ron Bedard/Alamy (bottom) Jack Hollingsworth/Jupiter Images p. 761: (left) Richard Majlinder/Shutterstock (right) Joe Gough/Shutterstock p. 778: iStockphoto p. 807: Jpatava/Dreamstime p. 811: Getty Images/Thinkstock p. 812: Vchphoto/Dreamstime p. 831: (clockwise from left) Karen Grigoryan/Shutterstock; Tatiana Grozetskaya/Shutterstock; Noam Armonn/Shutterstock p. 847: B. O'Kane/Alamy p. 858: Exactostock/SuperStock p. 871: Erperlstrom/Shutterstock p. 872: iStockphoto p. 911: (clockwise from left) Chad Ryan/CSM/Landov; Chad Ryan/CSM/Landov; Denis Pepin/Shutterstock p. 919: Monika Wisniewska/Shutterstock p. 927: Joggie Botma/Shutterstock p. 935: Chad Ryan/CSM/Landov p. 955: Jean Valley/Shutterstock p. 960: Jeff Kowalsky/AFP/Getty Images p. 962: Frontpage/Shutterstock p. 973: Altrendo Images/Getty Images p. 979: Anna Baburkina/Shutterstock p. 986: Basphoto/Dreamstime

Answers

Chapter R

Exercise Set R.1

1. $\frac{2}{3}, 6, -2.45, 18.\bar{4}, -11, \sqrt[3]{27}, 5\frac{1}{6}, -\frac{8}{7}, 0, \sqrt{16}$
 3. $\sqrt{3}, \sqrt[6]{26}, 7.151551555\dots, -\sqrt{35}, \sqrt[3]{3}$
 5. $6, \sqrt[3]{27}, 0, \sqrt{16}$ 7. $-11, 0$ 9. $\frac{2}{3}, -2.45, 18.\bar{4}, 5\frac{1}{6}, -\frac{8}{7}$

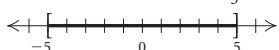
11. $[-5, 5]$; 

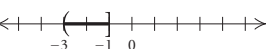
13. $(-3, -1]$; 

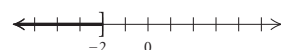
15. $(-\infty, -2]$; 

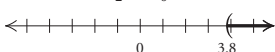
17. $(3.8, \infty)$; 

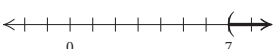
19. $(7, \infty)$; 

21. $(0, 5)$ 23. $[-9, -4]$ 25. $[x, x + h]$ 27. (p, ∞)

29. True 31. False 33. True 35. False 37. False

39. True 41. True 43. True 45. False

47. Commutative property of addition 49. Multiplicative identity property 51. Commutative property of multiplication 53. Commutative property of multiplication

55. Commutative property of addition 57. Multiplicative inverse property 59. 8.15 61. 295 63. $\sqrt{97}$

65. 0 67. $\frac{5}{4}$ 69. 22 71. 6 73. 5.4 75. $\frac{21}{8}$

77. 7 79. Answers may vary; 0.124124412444...

81. Answers may vary; -0.00999

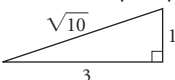
83. 

Exercise Set R.2

1. $\frac{1}{3^7}$ 3. $\frac{y^4}{x^5}$ 5. $\frac{t^6}{mn^{12}}$ 7. 1 9. z^7 11. 5^2 , or 25

13. 1 15. y^{-4} , or $\frac{1}{y^4}$ 17. $(x + 3)^2$ 19. 3^6 , or 729

21. $6x^5$ 23. $-15a^{-12}$, or $-\frac{15}{a^{12}}$ 25. $-42x^{-1}y^{-4}$, or $-\frac{42}{xy^4}$

27. $432x^7$ 29. $-200n^5$ 31. y^4 33. b^{-19} , or $\frac{1}{b^{19}}$

35. x^3y^{-3} , or $\frac{x^3}{y^3}$ 37. $8xy^{-5}$, or $\frac{8x}{y^5}$ 39. $16x^8y^4$

41. $-32x^{15}$ 43. $\frac{c^2d^4}{25}$ 45. $432m^{-8}$, or $\frac{432}{m^8}$

47. $\frac{8x^{-9}y^{21}}{z^{-3}}$, or $\frac{8y^{21}z^3}{x^9}$ 49. $2^{-5}a^{-20}b^{25}c^{-10}$, or $\frac{b^{25}}{32a^{20}c^{10}}$

51. 1.65×10^7 53. 4.37×10^{-7} 55. 2.346×10^{11}

57. 1.04×10^{-3} 59. 1.67×10^{-27} 61. 760,000

63. 0.000000109 65. 34,960,000,000 67. 0.0000000541

69. 231,900,000 71. 1.344×10^6 73. 2.21×10^{-10}

75. 8×10^{-14} 77. 2.5×10^5 79. About 6.737×10^2

pieces of trash 81. About 5.0667×10^4 people

per square mile 83. 2.48136×10^{13} mi 85. 1.332×10^{14}

disintegrations 87. 103 89. 2048 91. 5 93. \$3647.28

95. \$4704.84 97. \$170,797.30 99. \$419.67

101. x^{8t} 103. t^{8x} 105. $9x^{2a}y^{2b}$

Exercise Set R.3

1. $7x^3, -4x^2, 8x, 5; 3$ 3. $3a^4b, -7a^3b^3, 5ab, -2; 6$

5. $2ab^2 - 9a^2b + 6ab + 10$ 7. $3x + 2y - 2z - 3$

9. $-2x^2 + 6x - 2$ 11. $x^4 - 3x^3 - 4x^2 + 9x - 3$

13. $-21a^6$ 15. $54x^5y^5$

17. $2a^4 - 2a^3b - a^2b + 4ab^2 - 3b^3$ 19. $y^2 + 2y - 15$

21. $x^2 + 9x + 18$ 23. $2a^2 + 13a + 15$

25. $4x^2 + 8xy + 3y^2$ 27. $x^2 + 6x + 9$

29. $y^2 - 10y + 25$ 31. $25x^2 - 30x + 9$

33. $4x^2 + 12xy + 9y^2$ 35. $4x^4 - 12x^2y + 9y^2$

37. $n^2 - 36$ 39. $9y^2 - 16$ 41. $9x^2 - 4y^2$

43. $4x^2 + 12xy + 9y^2 - 16$ 45. $x^4 - 1$ 47. $a^{2n} - b^{2n}$

49. $a^{2n} + 2a^n b^n + b^{2n}$ 51. $x^6 - 1$ 53. $x^{a^2-b^2}$

55. $a^2 + b^2 + c^2 + 2ab + 2ac + 2bc$

Exercise Set R.4

1. $3(x + 6)$ 3. $2z^2(z - 4)$ 5. $4(a^2 - 3a + 4)$
7. $(b - 2)(a + c)$ 9. $(3x - 1)(x^2 + 6)$
11. $(y - 1)(y^2 + 2)$ 13. $12(2x - 3)(x^2 + 3)$
15. $(x - 1)(x^2 - 5)$ 17. $(a - 3)(a^2 - 2)$
19. $(w - 5)(w - 2)$ 21. $(x + 1)(x + 5)$
23. $(t + 3)(t + 5)$ 25. $(x + 3y)(x - 9y)$
27. $2(n - 12)(n + 2)$ 29. $(y - 7)(y + 3)$
31. $y^2(y - 2)(y - 7)$ 33. $2x(x + 3y)(x - 4y)$
35. $(2n - 7)(n + 8)$ 37. $(3x + 2)(4x + 1)$
39. $(4x + 3)(x + 3)$ 41. $(2y - 3)(y + 2)$
43. $(3a - 4b)(2a - 7b)$ 45. $4(3a - 4)(a + 1)$
47. $(z + 9)(z - 9)$ 49. $(4x + 3)(4x - 3)$
51. $6(x + y)(x - y)$ 53. $4x(y^2 + z)(y^2 - z)$
55. $7p(q^2 + y^2)(q + y)(q - y)$ 57. $(x + 6)^2$
59. $(3z - 2)^2$ 61. $(1 - 4x)^2$ 63. $a(a + 12)^2$
65. $4(p - q)^2$ 67. $(x + 4)(x^2 - 4x + 16)$
69. $(m - 6)(m^2 + 6m + 36)$ 71. $8(t + 1)(t^2 - t + 1)$
73. $3a^2(a - 2)(a^2 + 2a + 4)$ 75. $(t^2 + 1)(t^4 - t^2 + 1)$
77. $3ab(6a - 5b)$ 79. $(x - 4)(x^2 + 5)$
81. $8(x + 2)(x - 2)$ 83. Prime 85. $(m + 3n)(m - 3n)$
87. $(x + 4)(x + 5)$ 89. $(y - 5)(y - 1)$
91. $(2a + 1)(a + 4)$ 93. $(3x - 1)(2x + 3)$
95. $(y - 9)^2$ 97. $(3z - 4)^2$ 99. $(xy - 7)^2$
101. $4a(x + 7)(x - 2)$ 103. $3(z - 2)(z^2 + 2z + 4)$
105. $2ab(2a^2 + 3b^2)(4a^4 - 6a^2b^2 + 9b^4)$
107. $(y - 3)(y + 2)(y - 2)$ 109. $(x - 1)(x^2 + 1)$
111. $5(m^2 + 2)(m^2 - 2)$ 113. $2(x + 3)(x + 2)(x - 2)$
115. $(2c - d)^2$ 117. $(m^3 + 10)(m^3 - 2)$
119. $p(1 - 4p)(1 + 4p + 16p^2)$ 121. $(y^2 + 12)(y^2 - 7)$
123. $(y + \frac{4}{7})(y - \frac{2}{7})$ 125. $(x + \frac{3}{2})^2$ 127. $(x - \frac{1}{2})^2$
129. $h(3x^2 + 3xh + h^2)$ 131. $(y + 4)(y - 7)$
133. $(x^n + 8)(x^n - 3)$ 135. $(x + a)(x + b)$
137. $(5y^m + x^n - 1)(5y^m - x^n + 1)$
139. $y(y - 1)^2(y - 2)$

Exercise Set R.5

1. 12 3. -4 5. 3 7. 10 9. 11 11. -1
13. -12 15. 2 17. -1 19. $\frac{18}{5}$ 21. -3 23. 1
25. 0 27. $-\frac{1}{10}$ 29. 5 31. $-\frac{3}{2}$ 33. $\frac{20}{7}$ 35. -7, 4
37. -5, 0 39. -3 41. 10 43. -4, 8 45. -2, $-\frac{2}{3}$
47. $-\frac{3}{4}, \frac{2}{3}$ 49. $-\frac{4}{3}, \frac{7}{4}$ 51. -2, 7 53. -6, 6
55. -12, 12 57. $-\sqrt{10}, \sqrt{10}$ 59. $-\sqrt{3}, \sqrt{3}$
61. $b = \frac{2A}{h}$ 63. $w = \frac{P - 2l}{2}$ 65. $h = \frac{2A}{b_1 + b_2}$
67. $\pi = \frac{3V}{4r^3}$ 69. $C = \frac{5}{9}(F - 32)$ 71. $A = \frac{C - By}{x}$
73. $h = \frac{p - l - 2w}{2}$ 75. $y = \frac{2x - 6}{3}$ 77. $b = \frac{a}{1 + cd}$
79. $x = \frac{z}{y - y^2}$ 81. $\frac{23}{66}$ 83. 8 85. $-\frac{6}{5}, -\frac{1}{4}, 0, \frac{2}{3}$
87. -3, -2, 3

Exercise Set R.6

1. $\{x | x \text{ is a real number}\}$ 3. $\{x | x \text{ is a real number and } x \neq 0 \text{ and } x \neq 1\}$
5. $\{x | x \text{ is a real number and } x \neq -5 \text{ and } x \neq 1\}$ 7. $\{x | x \text{ is a real number and } x \neq -2 \text{ and } x \neq 2 \text{ and } x \neq -5\}$
9. $\frac{x + 2}{x - 2}$
11. $\frac{x - 3}{x}$ 13. $\frac{2(y + 4)}{y - 1}$ 15. $-\frac{1}{x + 8}$ 17. 1
19. $\frac{(x - 5)(3x + 2)}{7x}$ 21. $\frac{a + 2}{a - 5}$ 23. $m + n$
25. $\frac{3(x - 4)}{2(x + 4)}$ 27. $\frac{1}{x + y}$ 29. $\frac{x - y - z}{x + y + z}$ 31. $\frac{2}{x}$
33. 1 35. $\frac{7}{8z}$ 37. $\frac{3x - 4}{(x + 2)(x - 2)}$
39. $\frac{-y + 10}{(y + 4)(y - 5)}$ 41. $\frac{4x - 8y}{(x + y)(x - y)}$ 43. $\frac{y - 2}{y - 1}$
45. $\frac{x + y}{2x - 3y}$ 47. $\frac{3x - 4}{(x - 2)(x - 1)}$ 49. $\frac{5a^2 + 10ab - 4b^2}{(a + b)(a - b)}$
51. $\frac{11x^2 - 18x + 8}{(2 + x)(2 - x)^2}$ or $\frac{11x^2 - 18x + 8}{(x + 2)(x - 2)^2}$ 53. 0
55. $\frac{a}{a + b}$ 57. $x - y$ 59. $\frac{c^2 - 2c + 4}{c}$ 61. $\frac{xy}{x - y}$
63. $\frac{a^2 - 1}{a^2 + 1}$ 65. $\frac{3(x - 1)^2(x + 2)}{(x - 3)(x + 3)(-x + 10)}$ 67. $\frac{1 + a}{1 - a}$
69. $\frac{b + a}{b - a}$ 71. $2x + h$ 73. $3x^2 + 3xh + h^2$
75. x^5 77. $\frac{(n + 1)(n + 2)(n + 3)}{2 \cdot 3}$
79. $\frac{x^3 + 2x^2 + 11x + 20}{2(x + 1)(2 + x)}$

Exercise Set R.7

1. 21 3. $3|y|$ 5. $|a - 2|$ 7. $-3x$ 9. $3x^2$ 11. 2
13. $6\sqrt{5}$ 15. $6\sqrt{2}$ 17. $3\sqrt[3]{2}$ 19. $8\sqrt{2}|c|d^2$
21. $2|x||y|\sqrt[4]{3x^2}$ 23. $|x - 2|$ 25. $5\sqrt{21}$ 27. $4\sqrt{5}$
29. $2x^2y\sqrt{6}$ 31. $3x\sqrt[3]{4y}$ 33. $2(x + 4)\sqrt[3]{(x + 4)^2}$
35. $\frac{m^2n^3}{2}$ 37. $\sqrt{5y}$ 39. $\frac{1}{2x}$ 41. $\frac{4a\sqrt[3]{a}}{3b}$ 43. $\frac{x\sqrt{7x}}{6y^3}$
45. $17\sqrt{2}$ 47. $4\sqrt{5}$ 49. $-2x\sqrt{2} - 12\sqrt{5x}$ 51. -12
53. $-9 - 5\sqrt{15}$ 55. $27 - 10\sqrt{2}$ 57. $11 - 2\sqrt{30}$
59. About 53.2 yd 61. (a) $h = \frac{a}{2}\sqrt{3}$; (b) $A = \frac{a^2}{4}\sqrt{3}$
63. 8 65. $\frac{\sqrt{21}}{7}$ 67. $\frac{\sqrt[3]{35}}{5}$ 69. $\frac{2\sqrt[3]{6}}{3}$ 71. $\sqrt{3} + 1$
73. $-\frac{\sqrt{6}}{6}$ 75. $\frac{6\sqrt{m} + 6\sqrt{n}}{m - n}$ 77. $\frac{10}{3\sqrt{2}}$ 79. $\frac{2}{\sqrt[3]{20}}$
81. $\frac{11}{\sqrt{33}}$ 83. $\frac{76}{27 + 3\sqrt{5} - 9\sqrt{3} - \sqrt{15}}$
85. $\frac{a - b}{3a\sqrt{a} - 3a\sqrt{b}}$ 87. $\sqrt[6]{y^5}$ 89. 8 91. $\frac{1}{5}$

93. $\frac{a^4\sqrt{a}}{\sqrt[3]{b^3}}$, or $a^4\sqrt[3]{\frac{a}{b^3}}$ 95. $mn^2\sqrt[3]{m^2n}$ 97. $17^{3/5}$ 99. $12^{4/5}$
 101. $11^{1/6}$ 103. $5^{5/6}$ 105. 4 107. $8a^2$
 109. $\frac{x^3}{3b^{-2}}$, or $\frac{x^3b^2}{3}$ 111. $x\sqrt[3]{y}$ 113. $n\sqrt[3]{mn^2}$
 115. $a\sqrt[12]{a^5} + a^2\sqrt[12]{a}$ 117. $\sqrt[6]{288}$ 119. $\sqrt[12]{x^{11}y^7}$
 121. $a\sqrt[6]{a^5}$ 123. $(a+x)\sqrt[12]{(a+x)^{11}}$
 125. $\frac{(2+x^2)\sqrt{1+x^2}}{1+x^2}$ 127. $a^{a/2}$

Review Exercises: Chapter R

1. True 2. False 3. True 4. True 5. $-7, 43, -\frac{4}{9}$,
 $0, \sqrt[3]{64}, 4\frac{3}{4}, \frac{12}{7}, 102$ 6. $43, 0, \sqrt[3]{64}, 102$
 7. $-7, 43, 0, \sqrt[3]{64}, 102$ 8. All of them 9. $43, \sqrt[3]{64}, 102$
 10. $\sqrt{17}, 2.191191119\dots, -\sqrt{2}, \sqrt[5]{5}$ 11. $(-4, 7]$
 12. 24 13. $\frac{7}{8}$ 14. 10 15. 2 16. -10 17. 0.000083
 18. 20,700,000 19. 4.05×10^5 20. 3.9×10^{-7}
 21. 1.395×10^3 22. 7.8125×10^{-22} 23. $-12x^2y^{-4}$,
 or $\frac{-12x^2}{y^4}$ 24. $8a^{-6}b^3c$, or $\frac{8b^3c}{a^6}$ 25. 3 26. -2 27. $\frac{b}{a}$
 28. $\frac{x+y}{xy}$ 29. -4 30. $27 - 10\sqrt{2}$ 31. $13\sqrt{5}$
 32. $x^3 + t^3$ 33. $10a^2 - 7ab - 12b^2$
 34. $10x^2y + xy^2 + 2xy - 11$ 35. $8x(4x^3 - 5y^3)$
 36. $(y+3)(y^2-2)$ 37. $(x+12)^2$
 38. $x(9x-1)(x+4)$ 39. $(3x-5)^2$
 40. $(2x-1)(4x^2+2x+1)$ 41. $3(6x^2-x+2)$
 42. $(x-1)(2x+3)(2x-3)$ 43. $6(x+2)(x^2-2x+4)$
 44. $(ab-3)(ab+2)$ 45. $(2x-1)(x+3)$ 46. 7
 47. -1 48. 3 49. $-\frac{1}{13}$ 50. -8 51. $-4, 5$
 52. $-6, \frac{1}{2}$ 53. $-1, 3$ 54. $-4, 4$ 55. $-\sqrt{7}, \sqrt{7}$
 56. 3 57. $\frac{x-5}{(x+5)(x+3)}$ 58. $y^3\sqrt[6]{y}$ 59. $\sqrt[3]{(a+b)^2}$
 60. $b\sqrt[5]{b^2}$ 61. $\frac{m^4n^2}{3}$ 62. $\frac{23-9\sqrt{3}}{22}$ 63. About 18.8 ft
 64. B 65. C 66. \$553.67 67. \$606.92 68. \$942.54
 69. \$857.57 70. $x^{2n} + 6x^n - 40$ 71. $t^{2a} + 2 + t^{-2a}$
 72. $y^{2b} - z^{2c}$ 73. $a^{3n} - 3a^{2n}b^n + 3a^n b^{2n} - b^{3n}$
 74. $(y^n + 8)^2$ 75. $(x^t - 7)(x^t + 4)$
 76. $m^{3n}(m^n - 1)(m^{2n} + m^n + 1)$ 77. Anya is probably
 not following the rules for order of operations. She is subtract-
 ing 6 from 15 first, then dividing the difference by 3, and finally
 multiplying the quotient by 4. The correct answer is 7.
 78. When the least common denominator is used, the
 multiplication in the numerators is often simpler and there is
 usually less simplification required after the addition or
 subtraction is performed.

79. $A^3 - B^3 = A^3 + (-B)^3$
 $= (A + (-B))(A^2 - A(-B) + (-B)^2)$
 $= (A - B)(A^2 + AB + B^2)$

80. Note that $26 > 25$, so $\sqrt{26} > \sqrt{25}$, or $\sqrt{26} > 5$.
 Then $10\sqrt{26} - 50 > 10 \cdot 5 - 50$, or $10\sqrt{26} - 50 > 0$.

Test: Chapter R

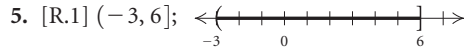
1. [R.1] (a) 0, $\sqrt[3]{8}, 29$; (b) $\sqrt{12}$; (c) 0, -5 ; (d) $6\frac{6}{7}, -\frac{13}{4}$,
 -1.2 2. [R.1] 17.6 3. [R.1] $\frac{15}{11}$ 4. [R.1] 0
 5. [R.1] $(-3, 6]$; 
 6. [R.1] 15 7. [R.2] -5 8. [R.2] 4509×10^6
 9. [R.2] 0.000086 10. [R.2] 7.5×10^6 11. [R.2] x^{-3} ,
 or $\frac{1}{x^3}$ 12. [R.2] $72y^{14}$ 13. [R.2] $-15a^4b^{-1}$, or $-\frac{15a^4}{b}$
 14. [R.3] $8xy^4 - 9xy^2 + 4x^2 + 2y - 7$
 15. [R.3] $3y^2 - 2y - 8$ 16. [R.3] $16x^2 - 24x + 9$
 17. [R.6] $\frac{x-y}{xy}$ 18. [R.7] $3\sqrt{5}$ 19. [R.7] $2\sqrt[3]{7}$
 20. [R.7] $21\sqrt{3}$ 21. [R.7] $6\sqrt{5}$ 22. [R.7] $4 + \sqrt{3}$
 23. [R.4] $2(2x+3)(2x-3)$ 24. [R.4] $(y+3)(y-6)$
 25. [R.4] $(2n-3)(n+4)$ 26. [R.4] $x(x+5)^2$
 27. [R.4] $(m-2)(m^2+2m+4)$ 28. [R.5] 4
 29. [R.5] $\frac{15}{4}$ 30. [R.5] $-\frac{3}{2}, -1$ 31. [R.5] $-\sqrt{11}, \sqrt{11}$
 32. [R.6] $\frac{x-5}{x-2}$ 33. [R.6] $\frac{x+3}{(x+1)(x+5)}$
 34. [R.7] $\frac{35+5\sqrt{3}}{46}$ 35. [R.7] $\sqrt[8]{m^3}$ 36. [R.7] $3^{5/6}$
 37. [R.7] 13 ft 38. [R.3] $x^2 - 2xy + y^2 - 2x + 2y + 1$

Chapter 1

Visualizing the Graph

1. H 2. B 3. D 4. A 5. G 6. I 7. C
 8. J 9. F 10. E

Exercise Set 1.1

1. A: $(-5, 4)$; B: $(2, -2)$; C: $(0, -5)$; D: $(3, 5)$; E: $(-5, -4)$;
 F: $(3, 0)$

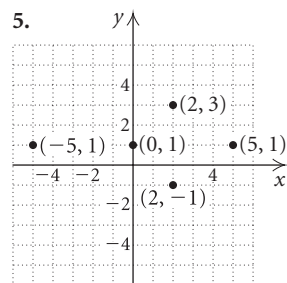
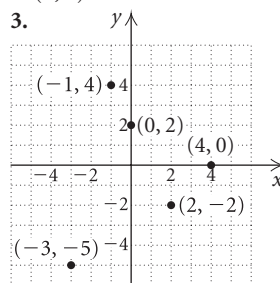

A-4 Answers

7. (1970, 4.7%), (1980, 6.2%), (1990, 8.0%), (2000, 10.4%), (2010, 12.8%)
 9. Yes; no 11. Yes; no 13. No; yes

15. No; yes

17. x -intercept: $(-3, 0)$;
 y -intercept: $(0, 5)$;

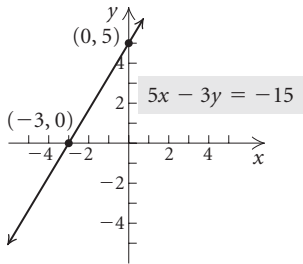

19. x -intercept: $(2, 0)$;
 y -intercept: $(0, 4)$;

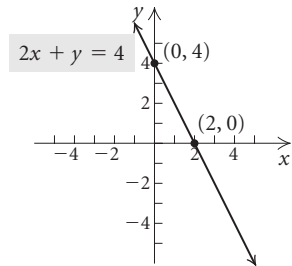

21. x -intercept: $(-4, 0)$;
 y -intercept: $(0, 3)$;

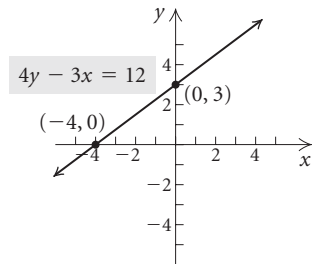

23.

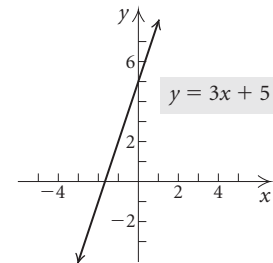

25.

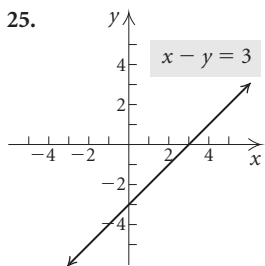

27.

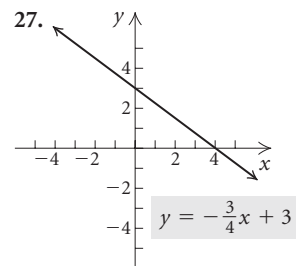

29.

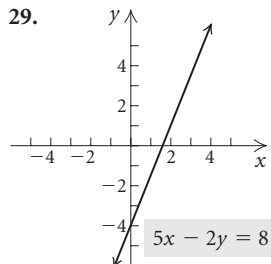

31.

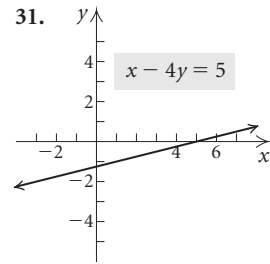

33.

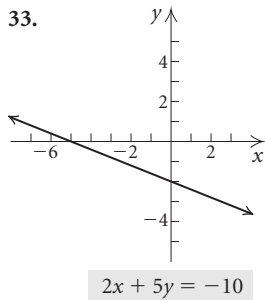

35.

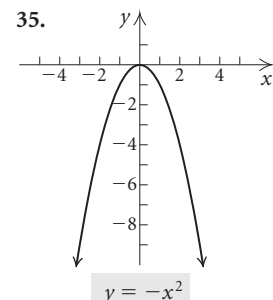

37.

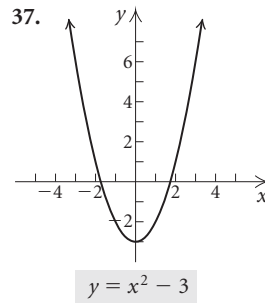

39.

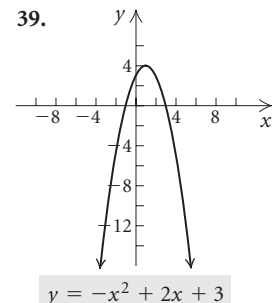

41. $\sqrt{10}$, 3.162 43. 13 45. $\sqrt{45}$, 6.708 47. 16
 49. $\frac{14}{3}$ 51. $\sqrt{128.05}$, 11.316 53. $\sqrt{a^2 + b^2}$ 55. 6.5
 57. Yes 59. No 61. $(-4, -6)$ 63. $(-\frac{1}{5}, \frac{1}{4})$
 65. $(4.95, -4.95)$ 67. $(-6, \frac{13}{2})$ 69. $(-\frac{5}{12}, \frac{13}{40})$
 71. $(-\frac{1}{2}, \frac{3}{2}), (\frac{7}{2}, \frac{1}{2}), (\frac{5}{2}, \frac{9}{2}), (-\frac{3}{2}, \frac{11}{2})$; no

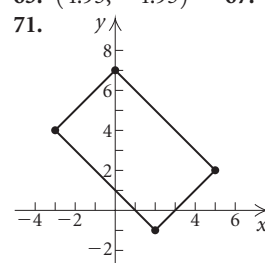

73. $(\frac{\sqrt{7} + \sqrt{2}}{2}, -\frac{1}{2})$ 75. $(x - 2)^2 + (y - 3)^2 = \frac{25}{9}$

77. $(x + 1)^2 + (y - 4)^2 = 25$
 79. $(x - 2)^2 + (y - 1)^2 = 169$
 81. $(x + 2)^2 + (y - 3)^2 = 4$

83. $(0, 0)$; 2;

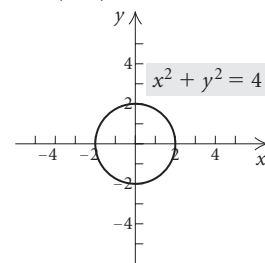

85. $(0, 3)$; 4;

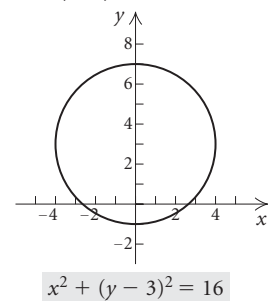

87. $(1, 5)$; 6;

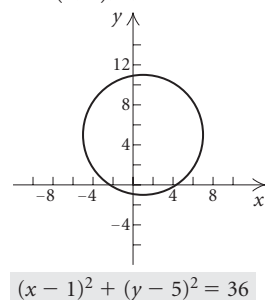

89. $(-4, -5)$; 3;

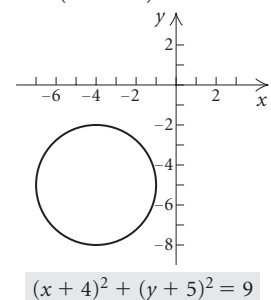

91. $(x + 2)^2 + (y - 1)^2 = 3^2$
 93. $(x - 5)^2 + (y + 5)^2 = 15^2$

95. Third 97. $\sqrt{h^2 + h + 2a - 2\sqrt{a^2 + ah}}$
 $\left(\frac{2a + h}{2}, \frac{\sqrt{a} + \sqrt{a + h}}{2}\right)$

99. $(x - 2)^2 + (y + 7)^2 = 36$ 101. (0, 4)
 103. (a) (0, -3); (b) 5 ft 105. Yes 107. Yes
 109. Let $P_1 = (x_1, y_1)$, $P_2 = (x_2, y_2)$, and

$M = \left(\frac{x_1 + x_2}{2}, \frac{y_1 + y_2}{2}\right)$. Let $d(AB)$ denote the distance from point A to point B.

(a) $d(P_1M) = \sqrt{\left(\frac{x_1 + x_2}{2} - x_1\right)^2 + \left(\frac{y_1 + y_2}{2} - y_1\right)^2}$
 $= \frac{1}{2}\sqrt{(x_2 - x_1)^2 + (y_2 - y_1)^2};$

$d(P_2M) = \sqrt{\left(\frac{x_1 + x_2}{2} - x_2\right)^2 + \left(\frac{y_1 + y_2}{2} - y_2\right)^2}$
 $= \frac{1}{2}\sqrt{(x_1 - x_2)^2 + (y_1 - y_2)^2}$
 $= \frac{1}{2}\sqrt{(x_2 - x_1)^2 + (y_2 - y_1)^2} = d(P_1M)$

(b) $d(P_1M) + d(P_2M) = \frac{1}{2}\sqrt{(x_2 - x_1)^2 + (y_2 - y_1)^2}$
 $+ \frac{1}{2}\sqrt{(x_2 - x_1)^2 + (y_2 - y_1)^2}$
 $= \sqrt{(x_2 - x_1)^2 + (y_2 - y_1)^2}$
 $= d(P_1P_2)$

Exercise Set 1.2

1. Yes 3. Yes 5. No 7. Yes 9. Yes 11. Yes
 13. No 15. Function; domain: {2, 3, 4}; range: {10, 15, 20}
 17. Not a function; domain: {-7, -2, 0}; range: {3, 1, 4, 7}
 19. Function; domain: {-2, 0, 2, 4, -3}; range: {1}
 21. (a) 1; (b) 6; (c) 22; (d) $3x^2 + 2x + 1$;
 (e) $3t^2 - 4t + 2$ 23. (a) 8; (b) -8; (c) $-x^3$;
 (d) $27y^3$; (e) $8 + 12h + 6h^2 + h^3$ 25. (a) $\frac{1}{8}$; (b) 0;
 (c) does not exist; (d) $\frac{81}{53}$, or approximately 1.5283;
 (e) $\frac{x + h - 4}{x + h + 3}$ 27. 0; does not exist; does not exist as a real

number; $\frac{1}{\sqrt{3}}$, or $\frac{\sqrt{3}}{3}$

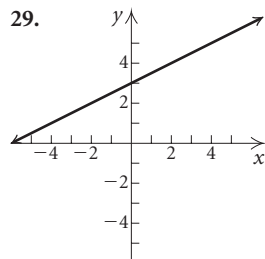

$f(x) = \frac{1}{2}x + 3$

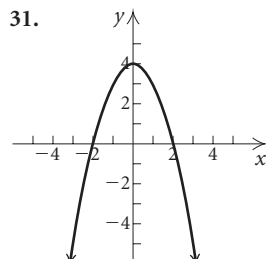

$f(x) = -x^2 + 4$

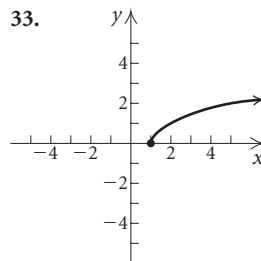

$f(x) = \sqrt{x - 1}$

35. $h(1) = -2$; $h(3) = 2$;
 $h(4) = 1$ 37. $s(-4) = 3$;
 $s(-2) = 0$; $s(0) = -3$
 39. $f(-1) = 2$; $f(0) = 0$;
 $f(1) = -2$ 41. No 43. Yes
 45. Yes 47. No 49. All real
 numbers, or $(-\infty, \infty)$
 51. All real numbers, or
 $(-\infty, \infty)$ 53. $\{x | x \neq 0\}$,
 or $(-\infty, 0) \cup (0, \infty)$
 55. $\{x | x \neq 2\}$, or $(-\infty, 2) \cup (2, \infty)$
 57. $\{x | x \neq -1 \text{ and } x \neq 5\}$, or
 $(-\infty, -1) \cup (-1, 5) \cup (5, \infty)$ 59. $\{x | x \neq 0 \text{ and } x \neq 7\}$,
 or $(-\infty, 0) \cup (0, 7) \cup (7, \infty)$ 61. All real numbers, or
 $(-\infty, \infty)$ 63. Domain: $[0, 5]$; range: $[0, 3]$
 65. Domain: $[-2\pi, 2\pi]$; range: $[-1, 1]$ 67. Domain:
 $(-\infty, \infty)$; range: $\{-3\}$ 69. Domain: $[-5, 3]$;
 range: $[-2, 2]$ 71. Domain: all real numbers, or $(-\infty, \infty)$;
 range: $[0, \infty)$ 73. Domain: all real numbers, or $(-\infty, \infty)$;
 range: all real numbers, or $(-\infty, \infty)$ 75. Domain: all real
 numbers, or $(-\infty, \infty)$; range: all real numbers, or $(-\infty, \infty)$
 77. Domain: $(-\infty, 7]$; range: $[0, \infty)$ 79. Domain: all real
 numbers, or $(-\infty, \infty)$; range: $(-\infty, 3]$ 81. (a) 2015:
 \$23.57; 2020: \$25.63; (b) about 41 yr after 1990, or in 2031
 83. 645 m; 0 m 84. [1.1] (-3, -2), yes; (2, -3), no
 85. [1.1] (0, -7), no; (8, 11), yes 86. [1.1] $(\frac{4}{5}, -2)$,
 yes; $(\frac{11}{5}, \frac{1}{10})$, yes

87. [1.1]

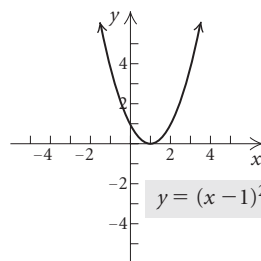

$y = (x - 1)^2$

89. [1.1]

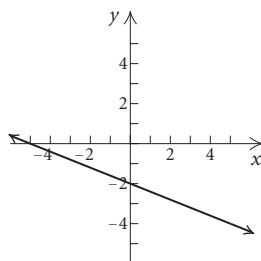

$-2x - 5y = 10$

88. [1.1]

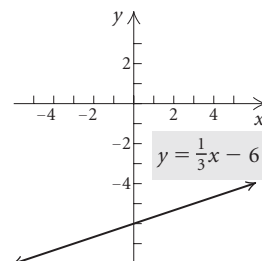

$y = \frac{1}{3}x - 6$

90. [1.1]

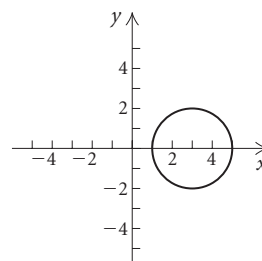

$(x - 3)^2 + y^2 = 4$

91. All real numbers, or $(-\infty, \infty)$ 93. $\{x | x \leq 8\}$, or
 $(-\infty, 8]$ 95. $\{x | x \geq -6 \text{ and } x \neq -2 \text{ and } x \neq 3\}$, or
 $[-6, -2) \cup (-2, 3) \cup (3, \infty)$ 97. $\{x | -5 \leq x \leq 3\}$,
 or $[-5, 3]$ 99. $f(x) = x, g(x) = x + 1$ 101. -7

Visualizing the Graph

1. E 2. D 3. A 4. J 5. C 6. F 7. H
8. G 9. B 10. I

Exercise Set 1.3

1. (a) Yes; (b) yes; (c) yes 3. (a) Yes; (b) no; (c) no 5. $\frac{6}{5}$ 7. $-\frac{3}{5}$ 9. 0 11. $\frac{1}{5}$ 13. Not defined
15. 0.3 17. 0 19. $-\frac{6}{5}$ 21. $-\frac{1}{3}$ 23. Not defined
25. -2 27. 5 29. 0 31. 1.3 33. Not defined
35. $-\frac{1}{2}$ 37. -1 39. 0 41. The average rate of change in the number of used jets for sale from 1999 to 2009 was about 199 jets per year. 43. The average rate of change in coffee consumption per capita from 1970 to 2007 was about -0.24 gal per year. 45. The average rate of change in account overdraft fees from 2003 to 2009 was \$1.9 billion per year. 47. The average rate of change in the population of Flint, Michigan, over the 8-year period was about -1505 people per year. 49. $\frac{3}{5}; (0, -7)$ 51. Slope is not defined; there is no y -intercept. 53. $-\frac{1}{2}; (0, 5)$ 55. $-\frac{3}{2}; (0, 5)$ 57. $0; (0, -6)$
59. $\frac{4}{5}; (0, \frac{8}{5})$ 61. $\frac{1}{4}; (0, -\frac{1}{2})$

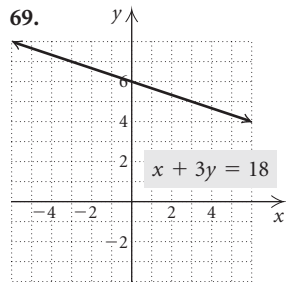
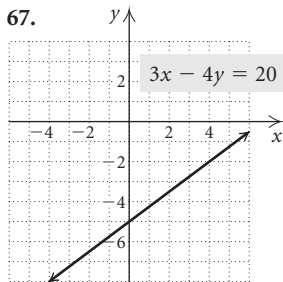
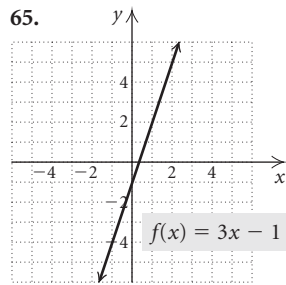
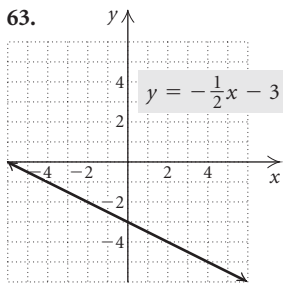

71. 1 atm, $1\frac{5}{33}$ atm, $1\frac{10}{33}$ atm, 2 atm, $7\frac{2}{33}$ atm 73. (a) 72 in., or 6 ft; (b) 100 in. to 170 in., or the interval $[100, 170]$; answers may vary 75. (a) $\frac{11}{10}$. For each mile per hour faster that the car travels, it takes $\frac{11}{10}$ ft longer to stop; (b) 6 ft, 11.5 ft, 22.5 ft, 55.5 ft, 72 ft; (c) $\{r \mid r > 0\}$, or $(0, \infty)$. If r is allowed to be 0, the function says that a stopped car has a reaction distance of $\frac{1}{2}$ ft. 77. $C(t) = 89 + 114.99t$; $C(24) = \$2848.76$ 79. $C(x) = 800 + 3x$; $C(75) = \$1025$
81. $[1.2] -\frac{5}{4}$ 82. $[1.2] 10$ 83. $[1.2] 40$ 84. $[1.2] a^2 + 3a$ 85. $[1.2] a^2 + 2ah + h^2 - 3a - 3h$
87. $-\frac{d}{10c}$ 89. 0 91. $2a + h$ 93. False
95. False 97. $f(x) = x + b$

Mid-Chapter Mixed Review: Chapter 1

1. False 2. True 3. False 4. x -intercept: $(5, 0)$; y -intercept: $(0, -8)$ 5. $\sqrt{605} = 11\sqrt{5} \approx 24.6$; $(-\frac{5}{2}, -4)$
6. $\sqrt{2} \approx 1.4$; $(-\frac{1}{4}, -\frac{3}{10})$ 7. $(x + 5)^2 + (y - 2)^2 = 169$
8. Center: $(3, -1)$; radius: 2

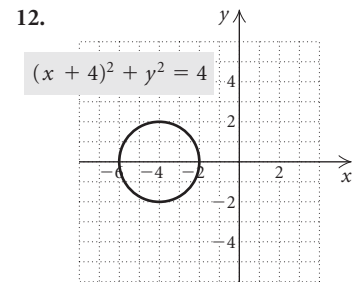
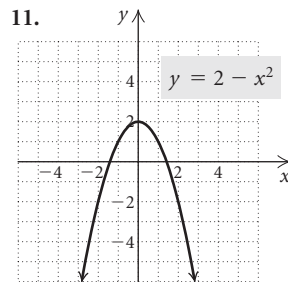
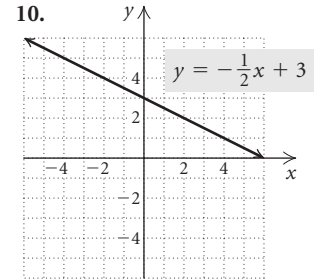
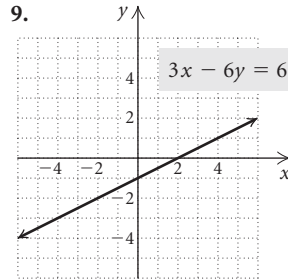

13. $f(-4) = -36$; $f(0) = 0$; $f(1) = -1$
14. $g(-6) = 0$; $g(0) = -2$; $g(3)$ is not defined
15. $\{x \mid x \text{ is a real number}\}$, or $(-\infty, \infty)$
16. $\{x \mid x \neq -5\}$, or $(-\infty, -5) \cup (-5, \infty)$
17. $\{x \mid x \neq -3 \text{ and } x \neq 1\}$, or $(-\infty, -3) \cup (-3, 1) \cup (1, \infty)$

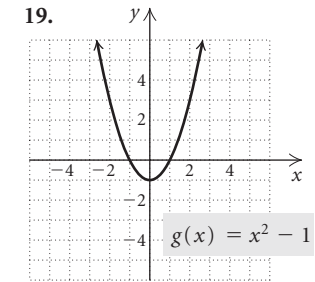
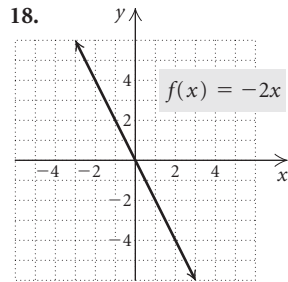

20. Domain: $[-4, 3]$; range: $[-4, 5]$ 21. Not defined
22. $-\frac{1}{4}$ 23. 0 24. Slope: $-\frac{1}{9}$; y -intercept: $(0, 12)$
25. Slope: 0; y -intercept: $(0, -6)$ 26. Slope is not defined; there is no y -intercept 27. Slope: $\frac{3}{16}$; y -intercept: $(0, \frac{1}{16})$
28. The sign of the slope indicates the slant of a line. A line that slants up from left to right has positive slope because corresponding changes in x and y have the same sign. A line that slants down from left to right has negative slope, because corresponding changes in x and y have opposite signs. A horizontal line has zero slope, because there is no change in y for a given change in x . A vertical line has undefined slope, because there is no change in x for a given change in y and division by 0

is undefined. The larger the absolute value of slope, the steeper the line. This is because a larger absolute value corresponds to a greater change in y , compared to the change in x , than a smaller absolute value. **29.** A vertical line ($x = a$) crosses the graph more than once; thus $x = a$ fails the vertical line test.

30. The domain of a function is the set of all inputs of the function. The range is the set of all outputs. The range depends on the domain. **31.** Let $A = (a, b)$ and $B = (c, d)$. The coordinates of a point C one-half of the way from A to B are

$\left(\frac{a+c}{2}, \frac{b+d}{2}\right)$. A point D that is one-half of the way from C to B is $\frac{1}{2} + \frac{1}{2} \cdot \frac{1}{2}$, or $\frac{3}{4}$ of the way from A to B . Its coordinates

are $\left(\frac{\frac{a+c}{2} + c}{2}, \frac{\frac{b+d}{2} + d}{2}\right)$, or $\left(\frac{a+3c}{4}, \frac{b+3d}{4}\right)$.

Then a point E that is one-half of the way from D to B is $\frac{3}{4} + \frac{1}{2} \cdot \frac{1}{4}$, or $\frac{7}{8}$ of the way from A to B . Its coordinates

are $\left(\frac{\frac{a+3c}{4} + c}{2}, \frac{\frac{b+3d}{4} + d}{2}\right)$, or $\left(\frac{a+7c}{8}, \frac{b+7d}{8}\right)$.

Exercise Set 1.4





1. 4, $(0, -2)$; $y = 4x - 2$ 3. $-1, (0, 0)$; $y = -x$
 5. 0, $(0, -3)$; $y = -3$ 7. $y = \frac{2}{3}x + 4$ 9. $y = -4x - 7$
 11. $y = -4.2x + \frac{3}{4}$ 13. $y = \frac{2}{5}x + \frac{19}{3}$ 15. $y = 8$
 17. $y = -\frac{3}{5}x - \frac{17}{5}$ 19. $y = -3x + 2$ 21. $y = -\frac{1}{2}x + \frac{7}{2}$
 23. $y = \frac{2}{3}x - 6$ 25. $y = 7.3$ 27. Horizontal: $y = -3$; vertical: $x = 0$ 29. Horizontal: $y = -1$; vertical: $x = \frac{2}{11}$
 31. $h(x) = -3x + 7$; 1 33. $f(x) = \frac{2}{5}x - 1$; -1
 35. Perpendicular 37. Neither parallel nor perpendicular
 39. Parallel 41. Perpendicular 43. $y = \frac{2}{7}x + \frac{29}{7}$; $y = -\frac{7}{2}x + \frac{31}{2}$ 45. $y = -0.3x - 2.1$; $y = \frac{10}{3}x + \frac{70}{3}$
 47. $y = -\frac{3}{4}x + \frac{1}{4}$; $y = \frac{4}{3}x - 6$ 49. $x = 3$; $y = -3$
 51. True 53. True 55. False 57. No 59. Yes
 61. (a) Using $(1, 679.8)$ and $(7, 1542.5)$, $y = 143.8x + 536$, where x is the number of years after 2001 and y is in millions; (b) 2012: about 2117.8 million Internet users; 2015: about 2549.2 million Internet users 63. Using $(0, 539)$ and $(4, 414)$, $y = -31.25x + 539$; 2012–2013: about 289,000 snow skis 65. Using $(4, 6912)$ and $(16, 10,691)$, $y = 314.92x + 5652$; 2005: about \$9746; 2014: about \$12,580 67. [1.3] Not defined 68. [1.3] -1
 69. [1.1] $x^2 + (y - 3)^2 = 6.25$ 70. [1.1] $(x + 7)^2 + (y + 1)^2 = \frac{81}{25}$ 71. -7.75
 73. 6.7% grade; $y = 0.067x$

Exercise Set 1.5

1. 4 3. All real numbers, or $(-\infty, \infty)$ 5. $-\frac{3}{4}$
 7. -9 9. 6 11. No solution 13. $\frac{11}{5}$ 15. $\frac{35}{6}$
 17. 8 19. -4 21. 6 23. -1 25. $\frac{4}{5}$ 27. $-\frac{3}{2}$
 29. $-\frac{2}{3}$ 31. $\frac{1}{2}$ 33. 25.6% 35. 16 knots

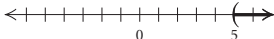
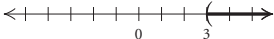
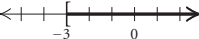
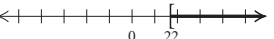
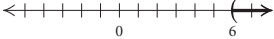
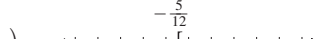
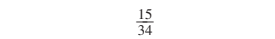
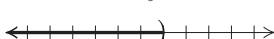
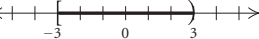
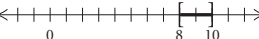
37. 10,040 ft 39. Toyota Tundra: 5740 lb; Ford Mustang: 3605 lb; Smart For Two: 1805 lb 41. CBS: 11.4 million viewers; ABC: 9.7 million viewers; NBC: 8.0 million viewers 43. \$1300 45. \$9800 47. \$8.50
 49. $26^\circ, 130^\circ, 24^\circ$ 51. Length: 93 m; width: 68 m
 53. Length: 100 yd; width: 65 yd 55. 67.5 lb 57. 3 hr
 59. 4.5 hr 61. 2.5 hr 63. \$2400 at 3%; \$2600 at 4%
 65. MySpace: 50.9 million visitors; Twitter: 19.1 million visitors 67. 709 ft 69. About 4,318,978 people
 71. -5 73. $\frac{11}{2}$ 75. 16 77. -12 79. 6
 81. 20 83. 25 85. 15 87. (a) $(4, 0)$; (b) 4
 89. (a) $(-2, 0)$; (b) -2 91. (a) $(-4, 0)$; (b) -4
 93. [1.4] $y = -\frac{3}{4}x + \frac{13}{4}$ 94. [1.4] $y = -\frac{3}{4}x + \frac{1}{4}$
 95. [1.1] 13 96. [1.1] $(-1, \frac{1}{2})$ 97. [1.2] $f(-3) = \frac{1}{2}$; $f(0) = 0$; $f(3)$ does not exist. 98. [1.3] $m = 7$; y -intercept: $(0, -\frac{1}{2})$ 99. Yes 101. No 103. $-\frac{2}{3}$ 105. No; the 6-oz cup costs about 6.4% more per ounce. 107. 11.25 mi

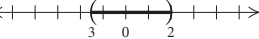
Exercise Set 1.6

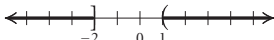
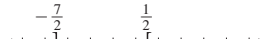
1. $\{x | x > 5\}$, or $(5, \infty)$; 
 3. $\{x | x > 3\}$, or $(3, \infty)$; 
 5. $\{x | x \geq -3\}$, or $[-3, \infty)$; 
 7. $\{y | y \geq \frac{22}{13}\}$, or $[\frac{22}{13}, \infty)$; 
 9. $\{x | x > 6\}$, or $(6, \infty)$; 
 11. $\{x | x \geq -\frac{5}{12}\}$, or $[-\frac{5}{12}, \infty)$; 
 13. $\{x | x \leq \frac{15}{34}\}$, or $(-\infty, \frac{15}{34}]$; 
 15. $\{x | x < 1\}$, or $(-\infty, 1)$; 
 17. $[-3, 3)$; 
 19. $[8, 10]$; 
 21. $[-7, -1]$; 
 23. $(-\frac{3}{2}, 2)$; 
 25. $(1, 5]$; 
 27. $(-\frac{11}{3}, \frac{13}{3})$; 
 29. $(-\infty, -2] \cup (1, \infty)$; 
 31. $(-\infty, -\frac{7}{2}] \cup [\frac{1}{2}, \infty)$; 

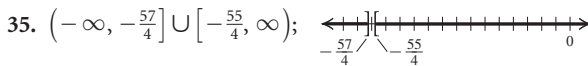
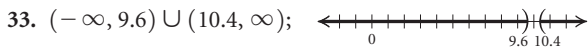

37. More than 4 yr after 2002 39. Less than 4 hr
 41. \$5000 43. \$12,000 45. Sales greater than \$18,000
 47. [1.2] Function; domain; range; domain; exactly one; range
 48. [1.1] Midpoint formula 49. [1.1] x-intercept
 50. [1.3] Constant; identity 51. $(-\frac{1}{4}, \frac{5}{9}]$ 53. $(-\frac{1}{8}, \frac{1}{2})$

Review Exercises: Chapter 1

1. True 2. True 3. False 4. False 5. True
 6. False 7. Yes; no 8. Yes; no
 9. x-intercept: (3, 0); y-intercept: (0, -2);
 10. x-intercept: (2, 0); y-intercept: (0, 5);

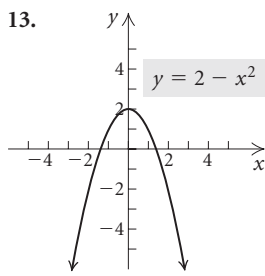
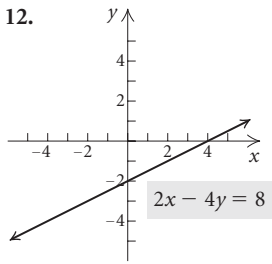
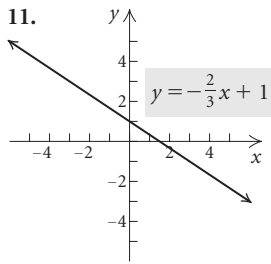
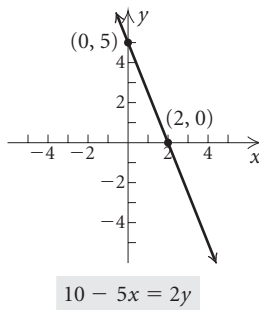
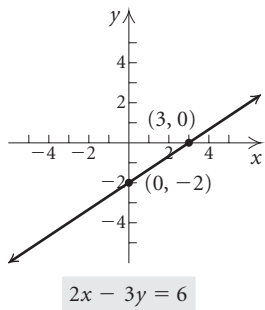

14. $\sqrt{34} \approx 5.831$
 15. $(\frac{1}{2}, \frac{11}{2})$

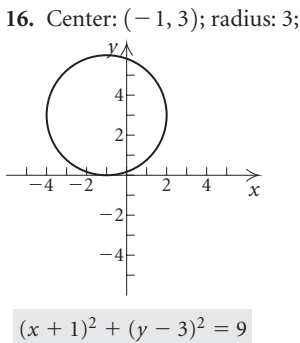

17. $x^2 + (y + 4)^2 = \frac{9}{4}$
 18. $(x + 2)^2 + (y - 6)^2 = 13$
 19. $(x - 2)^2 + (y - 4)^2 = 26$
 20. No 21. Yes 22. Not a function; domain: $\{3, 5, 7\}$; range: $\{1, 3, 5, 7\}$
 23. Function; domain: $\{-2, 0, 1, 2, 7\}$; range: $\{-7, -4, -2, 2, 7\}$

24. (a) -3; (b) 9; (c) $a^2 - 3a - 1$; (d) $x^2 + x - 3$

25. (a) 0; (b) $\frac{x - 6}{x + 6}$; (c) does not exist; (d) $-\frac{5}{3}$

26. $f(2) = -1$; $f(-4) = -3$; $f(0) = -1$ 27. No
 28. Yes 29. No 30. Yes 31. All real numbers, or $(-\infty, \infty)$ 32. $\{x \mid x \neq 0\}$, or $(-\infty, 0) \cup (0, \infty)$
 33. $\{x \mid x \neq 5 \text{ and } x \neq 1\}$, or $(-\infty, 1) \cup (1, 5) \cup (5, \infty)$
 34. $\{x \mid x \neq -4 \text{ and } x \neq 4\}$, or $(-\infty, -4) \cup (-4, 4) \cup (4, \infty)$
 35. Domain: $[-4, 4]$; range: $[0, 4]$ 36. Domain: $(-\infty, \infty)$; range: $[0, \infty)$ 37. Domain: $(-\infty, \infty)$; range: $(-\infty, \infty)$
 38. Domain: $(-\infty, \infty)$; range: $[0, \infty)$ 39. (a) Yes; (b) no; (c) no, strictly speaking, but data might be modeled by a linear regression function.
 40. (a) Yes; (b) yes; (c) yes 41. $\frac{5}{3}$
 42. 0 43. Not defined 44. The average rate of change over the 19-year period was about \$0.11 per year. 45. $m = -\frac{7}{11}$; y-intercept: $(0, -6)$ 46. $m = -2$; y-intercept: $(0, -7)$

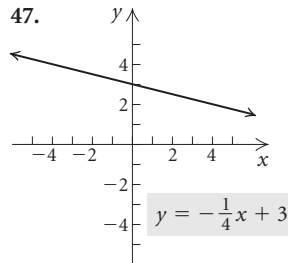

47. 48. $C(t) = 60 + 44t$; \$588
 49. (a) 70°C, 220°C, 10,020°C; (b) $[0, 5600]$
 50. $y = -\frac{2}{3}x - 4$
 51. $y = 3x + 5$
 52. $y = \frac{1}{3}x - \frac{1}{3}$
 53. Horizontal: $y = \frac{2}{5}$; vertical: $x = -4$

54. $h(x) = 2x - 5$; -5 55. Parallel 56. Neither
 57. Perpendicular 58. $y = -\frac{2}{3}x - \frac{1}{3}$ 59. $y = \frac{3}{2}x - \frac{5}{2}$
 60. Using $(98.7, 194.8)$ and $(120.7, 238.6)$, $H(c) = 1.99c - 1.70$ and $H(118 \text{ cm}) = 233.12 \text{ cm}$ 61. $\frac{3}{2}$ 62. -6
 63. -1 64. -21 65. $\frac{95}{24}$ 66. No solution 67. All real numbers, or $(-\infty, \infty)$ 68. 2780 milligrams 69. \$2300
 70. 3.4 hr 71. 3 72. 4 73. 0.2, or $\frac{1}{5}$ 74. 4

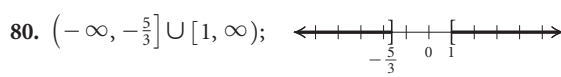
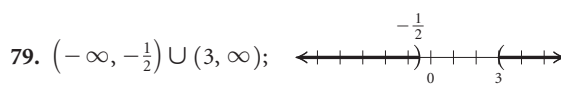
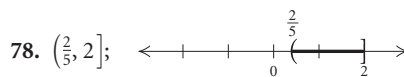
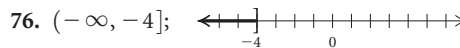
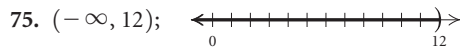

81. Years after 2013 82. Fahrenheit temperatures less than 113° 83. B 84. B 85. C 86. $(\frac{5}{2}, 0)$
 87. $\{x \mid x < 0\}$, or $(-\infty, 0)$
 88. $\{x \mid x \neq -3 \text{ and } x \neq 0 \text{ and } x \neq 3\}$, or $(-\infty, -3) \cup (-3, 0) \cup (0, 3) \cup (3, \infty)$ 89. Think of the slopes as $-\frac{3}{5}$ and $\frac{1}{2}$. The graph of $f(x)$ changes $\frac{3}{5}$ unit

vertically for each unit of horizontal change, whereas the graph of $g(x)$ changes $\frac{1}{2}$ unit vertically for each unit of horizontal change. Since $\frac{3}{5} > \frac{1}{2}$, the graph of $f(x) = -\frac{3}{5}x + 4$ is steeper than the graph of $g(x) = \frac{1}{2}x - 6$. **90.** If an equation contains no fractions, using the addition principle before using the multiplication principle eliminates the need to add or subtract fractions. **91.** The solution set of a disjunction is a union of sets, so it is only possible for a disjunction to have no solution when the solution set of each inequality is the empty set.

92. The graph of $f(x) = mx + b, m \neq 0$, is a straight line that is not horizontal. The graph of such a line intersects the x -axis exactly once. Thus the function has exactly one zero.

93. By definition, the notation $3 < x < 4$ indicates that $3 < x$ and $x < 4$. The disjunction $x < 3$ or $x > 4$ cannot be written $3 > x > 4$, or $4 < x < 3$, because it is not possible for x to be greater than 4 and less than 3. **94.** A function is a correspondence between two sets in which each member of the first set corresponds to exactly one member of the second set.

Test: Chapter 1

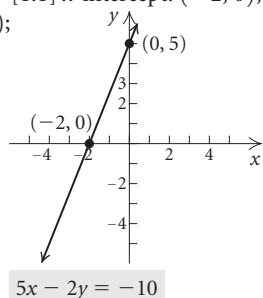

1. [1.1] Yes 2. [1.1] x -intercept: $(-2, 0)$;
 y -intercept: $(0, 5)$;

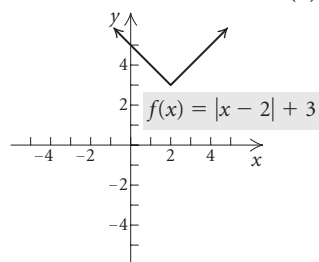

3. [1.1] $\sqrt{45} \approx 6.708$ 4. [1.1] $(-3, \frac{9}{2})$ 5. [1.1] Center: $(-4, 5)$; radius: 6 6. [1.1] $(x + 1)^2 + (y - 2)^2 = 5$
 7. [1.2] (a) Yes; (b) $\{-4, 3, 1, 0\}$; (c) $\{7, 0, 5\}$
 8. [1.2] (a) 8; (b) $2a^2 + 7a + 11$ 9. [1.2] (a) Does not exist; (b) 0 10. [1.2] 0 11. [1.2] (a) No; (b) yes
 12. [1.2] $\{x \mid x \neq 4\}$, or $(-\infty, 4) \cup (4, \infty)$
 13. [1.2] All real numbers, or $(-\infty, \infty)$
 14. [1.2] $\{x \mid -5 \leq x \leq 5\}$, or $[-5, 5]$
 15. [1.2] (a) (b) $(-\infty, \infty)$; (c) $[3, \infty)$

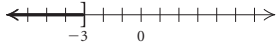
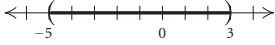

16. [1.3] Not defined 17. [1.3] $-\frac{11}{6}$ 18. [1.3] 0
 19. [1.3] The average rate of change in the percent of 12th graders who smoke from 1995 to 2008 was about 1.2% per year. **20.** [1.3] Slope: $\frac{3}{2}$; y -intercept: $(0, \frac{5}{2})$ **21.** [1.3] $C(t) = 80 + 39.95t$; \$1038.80 **22.** [1.4] $y = -\frac{5}{8}x - 5$

- 23.** [1.4] $y - 4 = -\frac{3}{4}(x - (-5))$, or $y - (-2) = -\frac{3}{4}(x - 3)$, or $y = -\frac{3}{4}x + \frac{1}{4}$ **24.** [1.4] $x = -\frac{3}{8}$ **25.** [1.4] Perpendicular
26. [1.4] $y - 3 = -\frac{1}{2}(x + 1)$, or $y = -\frac{1}{2}x + \frac{5}{2}$
27. [1.4] $y - 3 = 2(x + 1)$, or $y = 2x + 5$ **28.** [1.4] Using $(1, 12,485)$ and $(3, 11,788)$, $y = -348.5x + 12,833.5$, where x is the number of years after 2005 and y is the average number of miles per passenger car; 2010: 11,091 miles, 2013: 10,045.5 miles
29. [1.5] -1 **30.** [1.5] All real numbers, or $(-\infty, \infty)$ **31.** [1.5] -60 **32.** [1.5] $\frac{21}{11}$
33. [1.5] Length: 60 m; width: 45 m
34. [1.5] \$1.80 **35.** [1.5] -3
36. [1.6] $(-\infty, -3]$; 
37. [1.6] $(-5, 3)$; 
38. [1.6] $(-\infty, 2] \cup [4, \infty)$; 
39. [1.6] More than 6 hr **40.** [1.3] B **41.** [1.2] -2

Chapter 2

Exercise Set 2.1

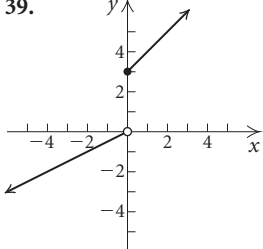
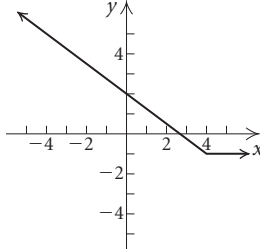
1. (a) $(-5, 1)$; (b) $(3, 5)$; (c) $(1, 3)$
 3. (a) $(-3, -1)$, $(3, 5)$; (b) $(1, 3)$; (c) $(-5, -3)$
 5. (a) $(-\infty, -8)$, $(-3, -2)$; (b) $(-8, -6)$;
 (c) $(-6, -3)$, $(-2, \infty)$ 7. Domain: $[-5, 5]$; range: $[-3, 3]$ 9. Domain: $[-5, -1] \cup [1, 5]$; range: $[-4, 6]$
 11. Domain: $(-\infty, \infty)$; range: $(-\infty, 3]$ 13. Relative maximum: 3.25 at $x = 2.5$; increasing: $(-\infty, 2.5)$; decreasing: $(2.5, \infty)$ 15. Relative maximum: 2.370 at $x = -0.667$; relative minimum: 0 at $x = 2$; increasing: $(-\infty, -0.667)$, $(2, \infty)$; decreasing: $(-0.667, 2)$ 17. Increasing: $(0, \infty)$; decreasing: $(-\infty, 0)$; relative minimum: 0 at $x = 0$
 19. Increasing: $(-\infty, 0)$; decreasing: $(0, \infty)$; relative maximum: 5 at $x = 0$ 21. Increasing: $(3, \infty)$; decreasing: $(-\infty, 3)$; relative minimum: 1 at $x = 3$
 23. $A(x) = x(30 - x)$, or $30x - x^2$
 25. $d(t) = \sqrt{(120t)^2 + 400^2}$ 27. $A(w) = 10w - \frac{w^2}{2}$
 29. $d(s) = \frac{14}{s}$ 31. (a) $A(x) = x(30 - x)$, or $30x - x^2$;
 (b) $\{x \mid 0 < x < 30\}$; (c) 15 ft by 15 ft
 33. (a) $V(x) = x(12 - 2x)(12 - 2x)$, or $4x(6 - x)^2$;
 (b) $\{x \mid 0 < x < 6\}$; (c) 8 cm by 8 cm by 2 cm
 35. $g(-4) = 0$; $g(0) = 4$; $g(1) = 5$; $g(3) = 5$
 37. $h(-5) = 1$; $h(0) = 1$; $h(1) = 3$; $h(4) = 6$
39.  **41.** 

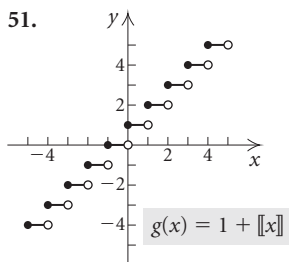
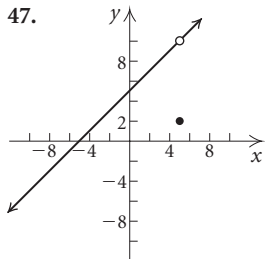
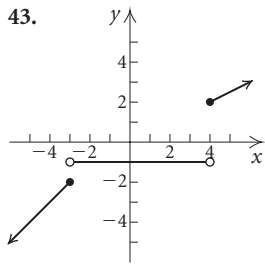

57. Domain: $(-\infty, \infty)$; range: $\{y \mid y \leq -2 \text{ or } y = -1 \text{ or } y \geq 2\}$

59. Domain: $(-\infty, \infty)$; range: $\{-5, -2, 4\}$;

$$f(x) = \begin{cases} -2, & \text{for } x < 2, \\ -5, & \text{for } x = 2, \\ 4, & \text{for } x > 2 \end{cases}$$

61. Domain: $(-\infty, \infty)$; range: $(-\infty, -1] \cup [2, \infty)$;

$$g(x) = \begin{cases} x, & \text{for } x \leq -1, \\ 2, & \text{for } -1 < x < 2, \\ x, & \text{for } x \geq 2 \end{cases}$$

or

$$g(x) = \begin{cases} x, & \text{for } x \leq -1, \\ 2, & \text{for } -1 < x \leq 2, \\ x, & \text{for } x > 2 \end{cases}$$

63. Domain: $[-5, 3]$; range: $(-3, 5)$;

$$h(x) = \begin{cases} x + 8, & \text{for } -5 \leq x < -3, \\ 3, & \text{for } -3 \leq x \leq 1, \\ 3x - 6, & \text{for } 1 < x \leq 3 \end{cases}$$

65. [1.2] (a) 38; (b) 38; (c) $5a^2 - 7$; (d) $5a^2 - 7$

66. [1.2] (a) 22; (b) -22; (c) $4a^3 - 5a$; (d) $-4a^3 + 5a$

67. [1.4] $y = -\frac{1}{8}x + \frac{7}{8}$ 68. [1.4] Slope: $\frac{2}{9}$;

y-intercept: $(0, \frac{1}{9})$

69. (a)

(b) $C(t) = 2(\lceil t \rceil + 1), t > 0$

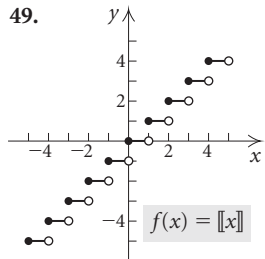
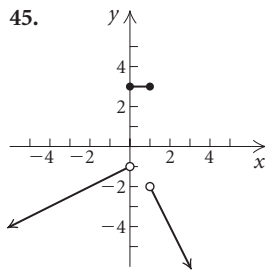

53. Domain: $(-\infty, \infty)$;

range: $(-\infty, 0) \cup [3, \infty)$

55. Domain: $(-\infty, \infty)$;

range: $[-1, \infty)$

71. $\{x \mid -5 \leq x < -4 \text{ or } 5 \leq x < 6\}$

73. (a) $h(r) = \frac{30 - 5r}{3}$; (b) $V(r) = \pi r^2 \left(\frac{30 - 5r}{3}\right)$;

(c) $V(h) = \pi h \left(\frac{30 - 3h}{5}\right)^2$

Exercise Set 2.2

1. 33 3. -1 5. Does not exist 7. 0 9. 1

11. Does not exist 13. 0 15. 5 17. (a) Domain of $f, g, f + g, f - g, fg$, and ff : $(-\infty, \infty)$;

domain of f/g : $(-\infty, \frac{3}{5}) \cup (\frac{3}{5}, \infty)$; domain of

g/f : $(-\infty, -\frac{3}{2}) \cup (-\frac{3}{2}, \infty)$; (b) $(f + g)(x) = -3x + 6$;

$(f - g)(x) = 7x$; $(fg)(x) = -10x^2 - 9x + 9$;

$(ff)(x) = 4x^2 + 12x + 9$; $(f/g)(x) = \frac{2x + 3}{3 - 5x}$;

$(g/f)(x) = \frac{3 - 5x}{2x + 3}$

19. (a) Domain of f : $(-\infty, \infty)$;

domain of g : $[-4, \infty)$; domain of $f + g, f - g$,

and fg : $[-4, \infty)$; domain of ff : $(-\infty, \infty)$;

domain of f/g : $(-4, \infty)$; domain of g/f : $[-4, 3) \cup (3, \infty)$;

(b) $(f + g)(x) = x - 3 + \sqrt{x + 4}$;

$(f - g)(x) = x - 3 - \sqrt{x + 4}$;

$(fg)(x) = (x - 3)\sqrt{x + 4}$; $(ff)(x) = x^2 - 6x + 9$;

$(f/g)(x) = \frac{x - 3}{\sqrt{x + 4}}$; $(g/f)(x) = \frac{\sqrt{x + 4}}{x - 3}$

21. (a) Domain of $f, g, f + g, f - g, fg$, and ff : $(-\infty, \infty)$;

domain of f/g : $(-\infty, 0) \cup (0, \infty)$;

domain of g/f : $(-\infty, \frac{1}{2}) \cup (\frac{1}{2}, \infty)$;

(b) $(f + g)(x) = -2x^2 + 2x - 1$;

$(f - g)(x) = 2x^2 + 2x - 1$; $(fg)(x) = -4x^3 + 2x^2$;

$(ff)(x) = 4x^2 - 4x + 1$; $(f/g)(x) = \frac{2x - 1}{-2x^2}$;

$(g/f)(x) = \frac{-2x^2}{2x - 1}$

23. (a) Domain of f : $[3, \infty)$;

domain of g : $[-3, \infty)$; domain of $f + g, f - g, fg$, and

ff : $[3, \infty)$; domain of f/g : $[3, \infty)$; domain of g/f : $(3, \infty)$;

(b) $(f + g)(x) = \sqrt{x - 3} + \sqrt{x + 3}$;

$(f - g)(x) = \sqrt{x - 3} - \sqrt{x + 3}$; $(fg)(x) = \sqrt{x^2 - 9}$;

$(ff)(x) = |x - 3|$; $(f/g)(x) = \frac{\sqrt{x - 3}}{\sqrt{x + 3}}$;

$(g/f)(x) = \frac{\sqrt{x + 3}}{\sqrt{x - 3}}$

25. (a) Domain of $f, g, f + g, f - g$,

fg , and ff : $(-\infty, \infty)$; domain of f/g : $(-\infty, 0) \cup (0, \infty)$;

domain of g/f : $(-\infty, -1) \cup (-1, \infty)$;

(b) $(f + g)(x) = x + 1 + |x|$; $(f - g)(x) = x + 1 - |x|$;

$(fg)(x) = (x + 1)|x|$; $(ff)(x) = x^2 + 2x + 1$;

$(f/g)(x) = \frac{x + 1}{|x|}$; $(g/f)(x) = \frac{|x|}{x + 1}$

27. (a) Domain of f, g ,

$f + g, f - g, fg$, and ff : $(-\infty, \infty)$;

domain of f/g : $(-\infty, -3) \cup (-3, \frac{1}{2}) \cup (\frac{1}{2}, \infty)$;

domain of g/f : $(-\infty, 0) \cup (0, \infty)$;

(b) $(f + g)(x) = x^3 + 2x^2 + 5x - 3$;
 $(f - g)(x) = x^3 - 2x^2 - 5x + 3$;
 $(fg)(x) = 2x^5 + 5x^4 - 3x^3$; $(ff)(x) = x^6$;
 $(f/g)(x) = \frac{x^3}{2x^2 + 5x - 3}$; $(g/f)(x) = \frac{2x^2 + 5x - 3}{x^3}$

29. (a) Domain of f : $(-\infty, -1) \cup (-1, \infty)$;
 domain of g : $(-\infty, 6) \cup (6, \infty)$; domain of $f + g, f - g$,
 and fg : $(-\infty, -1) \cup (-1, 6) \cup (6, \infty)$;
 domain of ff : $(-\infty, -1) \cup (-1, \infty)$;
 domain of f/g and g/f : $(-\infty, -1) \cup (-1, 6) \cup (6, \infty)$;

(b) $(f + g)(x) = \frac{4}{x + 1} + \frac{1}{6 - x}$;
 $(f - g)(x) = \frac{4}{x + 1} - \frac{1}{6 - x}$; $(fg)(x) = \frac{4}{(x + 1)(6 - x)}$;

$(ff)(x) = \frac{16}{(x + 1)^2}$; $(f/g)(x) = \frac{4(6 - x)}{x + 1}$;

$(g/f)(x) = \frac{x + 1}{4(6 - x)}$ 31. (a) Domain of

f : $(-\infty, 0) \cup (0, \infty)$; domain of g : $(-\infty, \infty)$; domain of
 $f + g, f - g, fg$, and ff : $(-\infty, 0) \cup (0, \infty)$;
 domain of f/g : $(-\infty, 0) \cup (0, 3) \cup (3, \infty)$;
 domain of g/f : $(-\infty, 0) \cup (0, \infty)$;

(b) $(f + g)(x) = \frac{1}{x} + x - 3$; $(f - g)(x) = \frac{1}{x} - x + 3$;

$(fg)(x) = 1 - \frac{3}{x}$; $(ff)(x) = \frac{1}{x^2}$; $(f/g)(x) = \frac{1}{x(x - 3)}$;

$(g/f)(x) = x(x - 3)$ 33. Domain of F : $[2, 11]$; domain of
 G : $[1, 9]$; domain of $F + G$: $[2, 9]$ 35. $[2, 3) \cup (3, 9]$

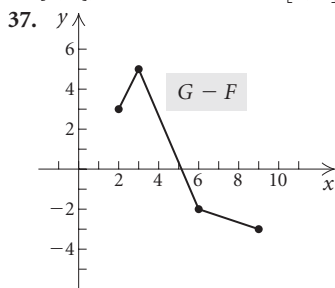

39. Domain of F : $[0, 9]$; domain of G : $[3, 10]$; domain of
 $F + G$: $[3, 9]$ 41. $[3, 6) \cup (6, 8) \cup (8, 9]$

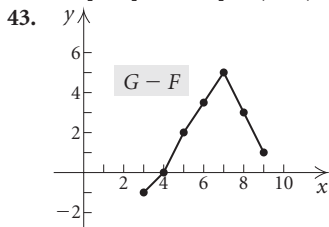

45. (a) $P(x) = -0.4x^2 + 57x - 13$; (b) $R(100) = 2000$;
 $C(100) = 313$; $P(100) = 1687$

47. 3 49. 6 51. $\frac{1}{3}$ 53. $\frac{-1}{3x(x + h)}$, or $-\frac{1}{3x(x + h)}$

55. $\frac{1}{4x(x + h)}$ 57. $2x + h$ 59. $-2x - h$

61. $6x + 3h - 2$ 63. $\frac{5|x + h| - 5|x|}{h}$

65. $3x^2 + 3xh + h^2$ 67. $\frac{7}{(x + h + 3)(x + 3)}$

69. $[1.1], [1.3]$ 70. $[1.1], [1.3]$

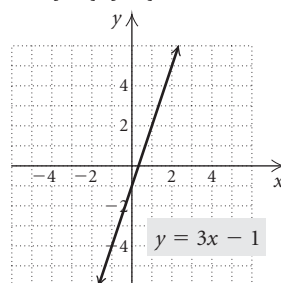

71. $[1.1], [1.3]$

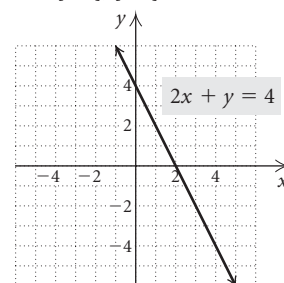
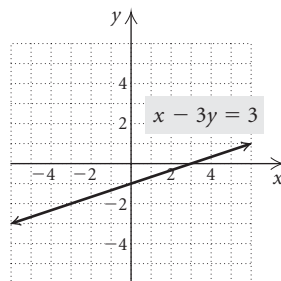

72. $[1.1]$

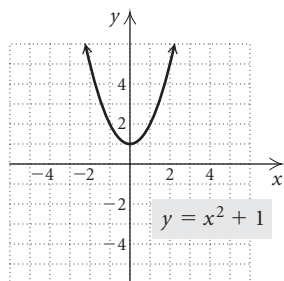

73. $f(x) = \frac{1}{x + 7}$, $g(x) = \frac{1}{x - 3}$; answers may vary

75. $(-\infty, -1) \cup (-1, 1) \cup (1, \frac{7}{3}) \cup (\frac{7}{3}, 3) \cup (3, \infty)$

Exercise Set 2.3

1. -8 3. 64 5. 218 7. -80 9. -6 11. 512

13. -32 15. x^9 17. $(f \circ g)(x) = (g \circ f)(x) = x$;
 domain of $f \circ g$ and $g \circ f$: $(-\infty, \infty)$

19. $(f \circ g)(x) = 3x^2 - 2x$; $(g \circ f)(x) = 3x^2 + 4x$;
 domain of $f \circ g$ and $g \circ f$: $(-\infty, \infty)$

21. $(f \circ g)(x) = 16x^2 - 24x + 6$; $(g \circ f)(x) = 4x^2 - 15$;
 domain of $f \circ g$ and $g \circ f$: $(-\infty, \infty)$

23. $(f \circ g)(x) = \frac{4x}{x - 5}$; $(g \circ f)(x) = \frac{1 - 5x}{4}$;

domain of $f \circ g$: $(-\infty, 0) \cup (0, 5) \cup (5, \infty)$;

domain of $g \circ f$: $(-\infty, \frac{1}{5}) \cup (\frac{1}{5}, \infty)$

25. $(f \circ g)(x) = (g \circ f)(x) = x$; domain of $f \circ g$ and
 $g \circ f$: $(-\infty, \infty)$ 27. $(f \circ g)(x) = 2\sqrt{x + 1}$;

$(g \circ f)(x) = \sqrt{2x + 1}$; domain of $f \circ g$: $[0, \infty)$; domain of
 $g \circ f$: $[-\frac{1}{2}, \infty)$ 29. $(f \circ g)(x) = 20$; $(g \circ f)(x) = 0.05$;

domain of $f \circ g$ and $g \circ f$: $(-\infty, \infty)$ 31. $(f \circ g)(x) = |x|$;
 $(g \circ f)(x) = x$; domain of $f \circ g$: $(-\infty, \infty)$; domain of
 $g \circ f$: $[-5, \infty)$ 33. $(f \circ g)(x) = 5 - x$;

$(g \circ f)(x) = \sqrt{1 - x^2}$; domain of $f \circ g$: $(-\infty, 3]$;
 domain of $g \circ f$: $[-1, 1]$

35. $(f \circ g)(x) = (g \circ f)(x) = x$;
 domain of $f \circ g$: $(-\infty, -1) \cup (-1, \infty)$;
 domain of $g \circ f$: $(-\infty, 0) \cup (0, \infty)$
 37. $(f \circ g)(x) = x^3 - 2x^2 - 4x + 6$;
 $(g \circ f)(x) = x^3 - 5x^2 + 3x + 8$; domain of $f \circ g$ and
 $g \circ f$: $(-\infty, \infty)$ 39. $f(x) = x^5$; $g(x) = 4 + 3x$

41. $f(x) = \frac{1}{x}$; $g(x) = (x - 2)^4$ 43. $f(x) = \frac{x - 1}{x + 1}$;

$g(x) = x^3$ 45. $f(x) = x^6$; $g(x) = \frac{2 + x^3}{2 - x^3}$

47. $f(x) = \sqrt{x}$; $g(x) = \frac{x - 5}{x + 2}$

49. $f(x) = x^3 - 5x^2 + 3x - 1$; $g(x) = x + 2$

51. (a) $r(t) = 3t$; (b) $A(r) = \pi r^2$; (c) $(A \circ r)(t) = 9\pi t^2$;
 the function gives the area of the ripple in terms of time t .

53. $P(m) = 1.5m + 3$ 55. [1.3] (c) 56. [1.3] None

57. [1.3] (b), (d), (f), and (h) 58. [1.3] (b) 59. [1.3] (a)

60. [1.3] (c) and (g) 61. [1.4] (c) and (g) 62. [1.4] (a)

and (f) 63. Only $(c \circ p)(a)$ makes sense. It represents the
 cost of the grass seed required to seed a lawn with area a .

Mid-Chapter Mixed Review: Chapter 2

1. True 2. False 3. True 4. (a) (2, 4);
 (b) $(-5, -3)$, $(4, 5)$; (c) $(-3, -1)$ 5. Relative maximum:
 6.30 at $x = -1.29$; relative minimum: -2.30 at $x = 1.29$;
 increasing: $(-\infty, -1.29)$, $(1.29, \infty)$; decreasing: $(-1.29, 1.29)$
 6. Domain: $[-5, -1] \cup [2, 5]$; range: $[-3, 5]$

7. $A(h) = \frac{h^2}{2} - h$ 8. -10 ; -8 ; 1 ; 3

9.  10. 1 11. -4 12. 5
 13. Does not exist

14. (a) Domain of f , g , $f + g$, $f - g$, fg , and ff : $(-\infty, \infty)$;
 domain of f/g : $(-\infty, -4) \cup (-4, \infty)$;

domain of g/f : $(-\infty, -\frac{5}{2}) \cup (-\frac{5}{2}, \infty)$;

(b) $(f + g)(x) = x + 1$; $(f - g)(x) = 3x + 9$;
 $(fg)(x) = -2x^2 - 13x - 20$; $(ff)(x) = 4x^2 + 20x + 25$;

$(f/g)(x) = \frac{2x + 5}{-x - 4}$; $(g/f)(x) = \frac{-x - 4}{2x + 5}$

15. (a) Domain of f : $(-\infty, \infty)$; domain of g , $f + g$, $f - g$,
 and fg : $[-2, \infty)$; domain of ff : $(-\infty, \infty)$; domain of
 f/g : $(-2, \infty)$; domain of g/f : $[-2, 1) \cup (1, \infty)$;

(b) $(f + g)(x) = x - 1 + \sqrt{x + 2}$;

$(f - g)(x) = x - 1 - \sqrt{x + 2}$;

$(fg)(x) = (x - 1)\sqrt{x + 2}$; $(ff)(x) = x^2 - 2x + 1$;

$(f/g)(x) = \frac{x - 1}{\sqrt{x + 2}}$; $(g/f)(x) = \frac{\sqrt{x + 2}}{x - 1}$

16. 4 17. $-2x - h$ 18. 6 19. 28 20. -24

21. 102 22. $(f \circ g)(x) = 3x + 2$; $(g \circ f)(x) = 3x + 4$;
 domain of $f \circ g$ and $g \circ f$: $(-\infty, \infty)$

23. $(f \circ g)(x) = 3\sqrt{x + 2}$; $(g \circ f)(x) = \sqrt{3x + 2}$;
 domain of $f \circ g$: $[0, \infty)$; domain of $g \circ f$: $[-\frac{2}{3}, \infty)$

24. The graph of $y = (h - g)(x)$ will be the same as the graph
 of $y = h(x)$ moved down b units. 25. Under the given

conditions, $(f + g)(x)$ and $(f/g)(x)$ have different domains if
 $g(x) = 0$ for one or more real numbers x . 26. If f and g are

linear functions, then any real number can be an input for
 each function. Thus the domain of $f \circ g =$ the domain of

$g \circ f = (-\infty, \infty)$. 27. This approach is not valid.
 Consider Exercise 23 in Section 2.3, for example. Since

$(f \circ g)(x) = \frac{4x}{x - 5}$, an examination of only this composed

function would lead to the incorrect conclusion that the
 domain of $f \circ g$ is $(-\infty, 5) \cup (5, \infty)$. However, we must also

exclude from the domain of $f \circ g$ those values of x that
 are not in the domain of g . Thus the domain of $f \circ g$ is

$(-\infty, 0) \cup (0, 5) \cup (5, \infty)$.

Visualizing the Graph

1. C 2. B 3. A 4. E 5. G 6. D 7. H
 8. I 9. F

Exercise Set 2.4

1. x -axis: no; y -axis: yes; origin: no 3. x -axis: yes; y -axis: no;
 origin: no 5. x -axis: no; y -axis: no; origin: yes 7. x -axis:

no; y -axis: yes; origin: no 9. x -axis: no; y -axis: no; origin: no

11. x -axis: no; y -axis: yes; origin: no 13. x -axis: no; y -axis:
 no; origin: yes 15. x -axis: no; y -axis: no; origin: yes

17. x -axis: yes; y -axis: yes; origin: yes 19. x -axis: no; y -axis:
 yes; origin: no 21. x -axis: yes; y -axis: yes; origin: yes

23. x -axis: no; y -axis: no; origin: no 25. x -axis: no; y -axis:
 no; origin: yes 27. x -axis: $(-5, -6)$; y -axis: $(5, 6)$; origin:

$(5, -6)$ 29. x -axis: $(-10, 7)$; y -axis: $(10, -7)$; origin:
 $(10, 7)$ 31. x -axis: $(0, 4)$; y -axis: $(0, -4)$; origin: $(0, 4)$

33. Even 35. Odd 37. Neither 39. Odd

41. Even 43. Odd 45. Neither 47. Even

49. Start with the graph
 of $f(x) = x^2$. Shift it
 right 3 units.

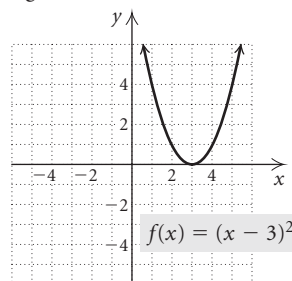

51. Start with the graph
 of $g(x) = x$. Shift it
 down 3 units.

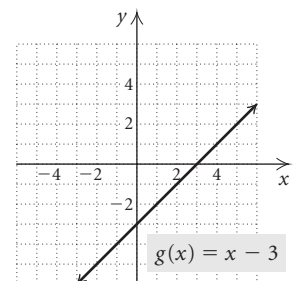

53. Start with the graph of $h(x) = \sqrt{x}$. Reflect it across the x -axis.

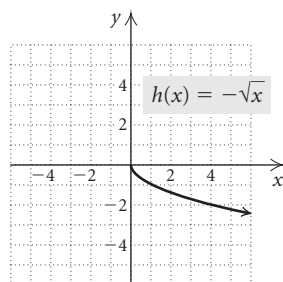

55. Start with the graph of $h(x) = \frac{1}{x}$. Shift it up 4 units.

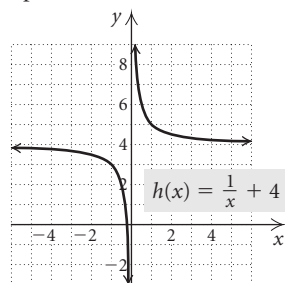

57. Start with the graph of $h(x) = x$. Stretch it vertically by multiplying each y -coordinate by 3. Then reflect it across the x -axis and shift it up 3 units.

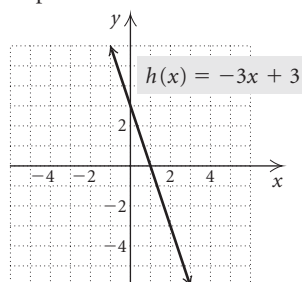

59. Start with the graph of $h(x) = |x|$. Shrink it vertically by multiplying each y -coordinate by $\frac{1}{2}$. Then shift it down 2 units.

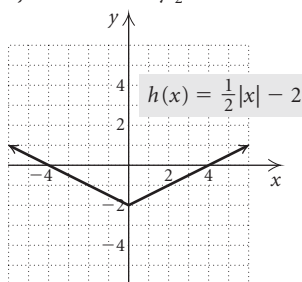

61. Start with the graph of $g(x) = x^3$. Shift it right 2 units. Then reflect it across the x -axis.

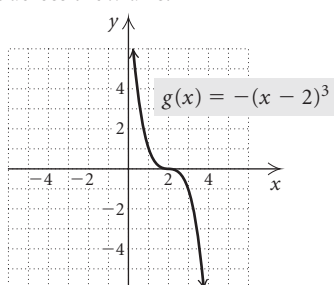

63. Start with the graph of $g(x) = x^2$. Shift it left 1 unit. Then shift it down 1 unit.

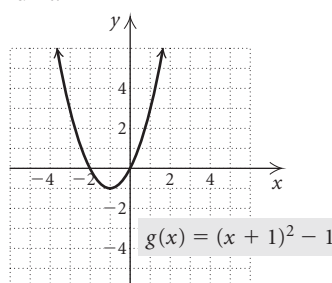

65. Start with the graph of $g(x) = x^3$. Shrink it vertically by multiplying each y -coordinate by $\frac{1}{3}$. Then shift it up 2 units.

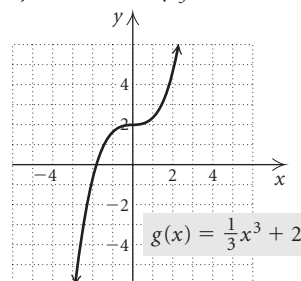

67. Start with the graph of $f(x) = \sqrt{x}$. Shift it left 2 units.

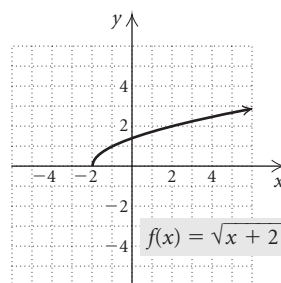

69. Start with the graph of $f(x) = \sqrt[3]{x}$. Shift it down 2 units.

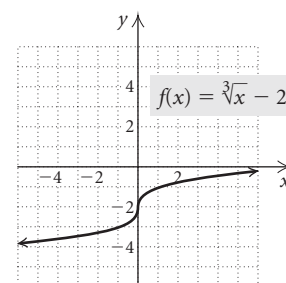

71. Start with the graph of $f(x) = |x|$. Shrink it horizontally by multiplying each x -coordinate by $\frac{1}{3}$ (or dividing each x -coordinate by 3).

73. Start with the graph of $h(x) = \frac{1}{x}$. Stretch it vertically by multiplying each y -coordinate by 2.

75. Start with the graph of $g(x) = \sqrt{x}$. Stretch it vertically by multiplying each y -coordinate by 3. Then shift it down 5 units.

77. Start with the graph of $f(x) = |x|$. Stretch it horizontally by multiplying each x -coordinate by 3. Then shift it down 4 units.

79. Start with the graph of $g(x) = x^2$. Shift it right 5 units, shrink it vertically by multiplying each y -coordinate by $\frac{1}{4}$, and then reflect it across the x -axis.

81. Start with the graph of $g(x) = \frac{1}{x}$. Shift it left 3 units, then up 2 units.

83. Start with the graph of $h(x) = x^2$. Shift it right 3 units. Then reflect it across the x -axis and shift it up 5 units.
 85. $(-12, 2)$ 87. $(12, 4)$ 89. $(-12, 2)$ 91. $(-12, 16)$
 93. B 95. A 97. $f(x) = -(x - 8)^2$

99. $f(x) = |x + 7| + 2$ 101. $f(x) = \frac{1}{2x} - 3$
 103. $f(x) = -(x - 3)^2 + 4$ 105. $f(x) = \sqrt{-(x + 2)} - 1$

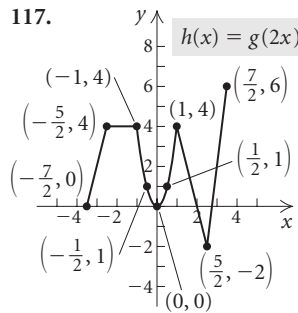
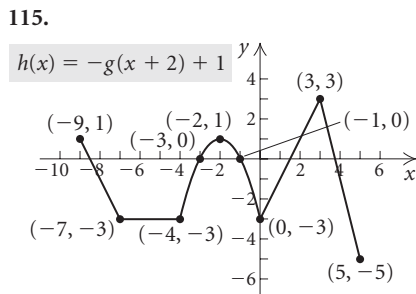
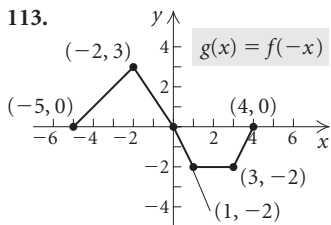
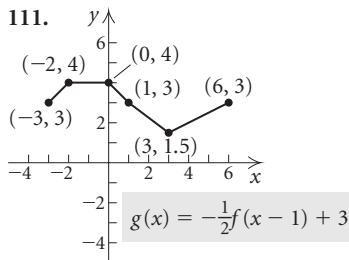
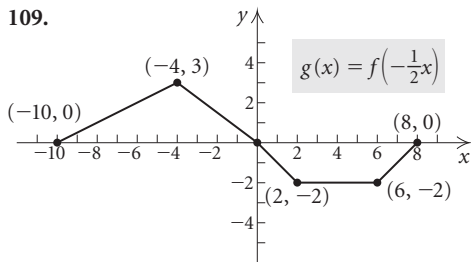
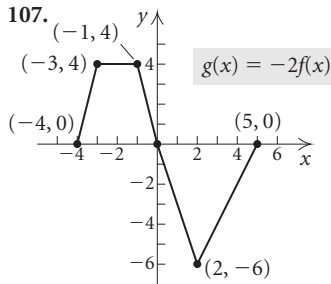

119. (f) 121. (f)
 123. (d) 125. (c)

127. $f(-x) = 2(-x)^4 - 35(-x)^3 + 3(-x) - 5 = 2x^4 + 35x^3 - 3x - 5 = g(x)$ 129. $g(x) = x^3 - 3x^2 + 2$
 131. $k(x) = (x + 1)^3 - 3(x + 1)^2$ 133. [1.5] Opening ceremonies: \$1100; closing ceremonies: \$775
 134. [1.5] 1.5 million games 135. [1.5] About \$83.3 billion
 136. [1.5] About 89.4 million returns

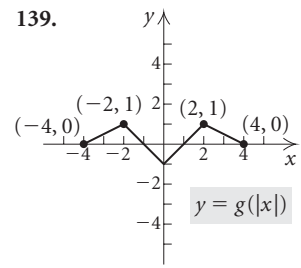
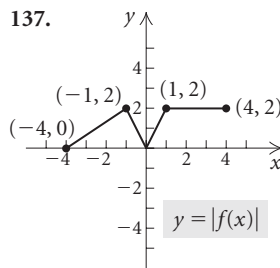

141. Odd 143. x -axis: yes; y -axis: no; origin: no
 145. x -axis: yes; y -axis: no; origin: no 147. 5 149. True
 151. $E(-x) = \frac{f(-x) + f(-(-x))}{2} = \frac{f(-x) + f(x)}{2} = E(x)$
 153. (a) $E(x) + O(x) = \frac{f(x) + f(-x)}{2} + \frac{f(x) - f(-x)}{2} = \frac{2f(x)}{2} = f(x)$; (b) $f(x) = \frac{-22x^2 + \sqrt{x} + \sqrt{-x} - 20}{2} + \frac{8x^3 + \sqrt{x} - \sqrt{-x}}{2}$

Exercise Set 2.5

1. 4.5; $y = 4.5x$ 3. 36; $y = \frac{36}{x}$ 5. 4; $y = 4x$ 7. 4;
 $y = \frac{4}{x}$ 9. $\frac{3}{8}$; $y = \frac{3}{8}x$ 11. 0.54; $y = \frac{0.54}{x}$ 13. \$1.41
 15. About 686 kg 17. 90 g 19. 3.5 hr 21. $66\frac{2}{3}$ cm
 23. 1.92 ft 25. $y = \frac{0.0015}{x^2}$ 27. $y = 15x^2$ 29. $y = xz$
 31. $y = \frac{3}{10}xz^2$ 33. $y = \frac{1}{5} \cdot \frac{xz}{wp}$, or $y = \frac{xz}{5wp}$ 35. 2.5 m
 37. 36 mph 39. 59 earned runs 41. [1.4] Parallel
 42. [1.5] Zero 43. [2.1] Relative minimum
 44. [2.4] Odd function 45. [2.5] Inverse variation
 47. \$2.32; \$2.80 49. $\frac{\pi}{4}$

Review Exercises: Chapter 2

1. True 2. False 3. True 4. True
 5. (a) $(-4, -2)$; (b) $(2, 5)$; (c) $(-2, 2)$
 6. (a) $(-1, 0)$, $(2, \infty)$; (b) $(0, 2)$; (c) $(-\infty, -1)$
 7. Increasing: $(0, \infty)$; decreasing: $(-\infty, 0)$; relative minimum: -1 at $x = 0$ 8. Increasing: $(-\infty, 0)$; decreasing: $(0, \infty)$; relative maximum: 2 at $x = 0$
 9. $A(l) = l(10 - l)$, or $10l - l^2$ 10. $A(x) = 2x\sqrt{4 - x^2}$
 11. (a) $A(x) = x^2 + \frac{432}{x}$; (b) $(0, \infty)$; (c) $x = 6$ in.,

height = 3 in.

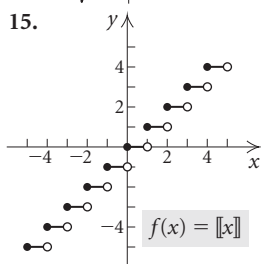
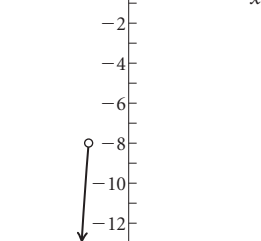
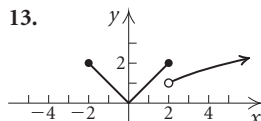
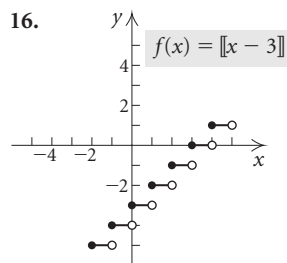
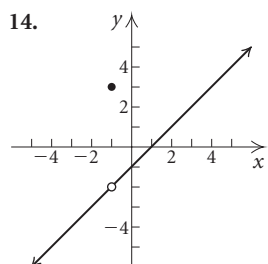
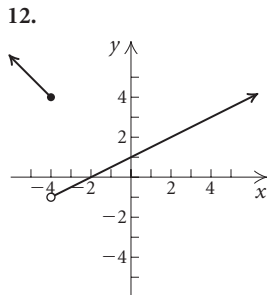

22. (a) Domain of f : $(-\infty, 0) \cup (0, \infty)$;
 domain of g : $(-\infty, \infty)$;
 domain of $f + g$, $f - g$, and fg : $(-\infty, 0) \cup (0, \infty)$;
 domain of f/g : $(-\infty, 0) \cup (0, \frac{3}{2}) \cup (\frac{3}{2}, \infty)$;
 (b) $(f + g)(x) = \frac{4}{x^2} + 3 - 2x$; $(f - g)(x) = \frac{4}{x^2} - 3 + 2x$;
 $(fg)(x) = \frac{12}{x^2} - \frac{8}{x}$; $(f/g)(x) = \frac{4}{x^2(3 - 2x)}$
 23. (a) Domain of f , g , $f + g$, $f - g$, and fg : $(-\infty, \infty)$;
 domain of f/g : $(-\infty, \frac{1}{2}) \cup (\frac{1}{2}, \infty)$; (b) $(f + g)(x) = 3x^2 + 6x - 1$; $(f - g)(x) = 3x^2 + 2x + 1$;
 $(fg)(x) = 6x^3 + 5x^2 - 4x$; $(f/g)(x) = \frac{3x^2 + 4x}{2x - 1}$

24. $P(x) = -0.5x^2 + 105x - 6$ 25. 2 26. $-2x - h$
 27. $\frac{-4}{x(x+h)}$, or $-\frac{4}{x(x+h)}$ 28. 9 29. 5 30. 128
 31. 580 32. 7 33. -509 34. $4x - 3$
 35. $-24 + 27x^3 - 9x^6 + x^9$

36. (a) $(f \circ g)(x) = \frac{4}{(3 - 2x)^2}$; $(g \circ f)(x) = 3 - \frac{8}{x^2}$;
 (b) domain of $f \circ g$: $(-\infty, \frac{3}{2}) \cup (\frac{3}{2}, \infty)$; domain of $g \circ f$: $(-\infty, 0) \cup (0, \infty)$

37. (a) $(f \circ g)(x) = 12x^2 - 4x - 1$; $(g \circ f)(x) = 6x^2 + 8x - 1$; (b) domain of $f \circ g$ and $g \circ f$: $(-\infty, \infty)$

38. $f(x) = \sqrt{x}$, $g(x) = 5x + 2$; answers may vary.
 39. $f(x) = 4x^2 + 9$, $g(x) = 5x - 1$; answers may vary.
 40. x -axis: yes; y -axis: yes; origin: yes 41. x -axis: yes; y -axis: yes; origin: yes 42. x -axis: no; y -axis: no; origin: no
 43. x -axis: no; y -axis: yes; origin: no 44. x -axis: no; y -axis: no; origin: yes 45. x -axis: no; y -axis: yes; origin: no
 46. Even 47. Even 48. Odd 49. Even 50. Even
 51. Neither 52. Odd 53. Even 54. Even 55. Odd
 56. $f(x) = (x + 3)^2$ 57. $f(x) = -\sqrt{x - 3} + 4$
 58. $f(x) = 2|x - 3|$

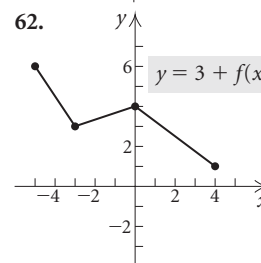
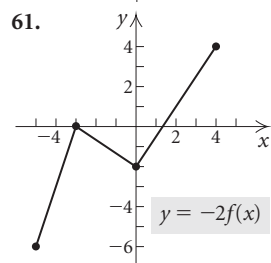
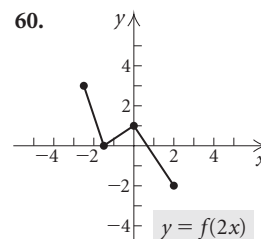
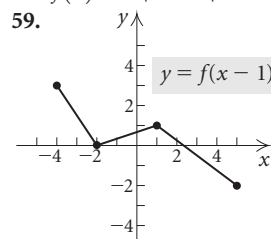

63. $y = 4x$ 64. $y = \frac{2}{3}x$ 65. $y = \frac{2500}{x}$ 66. $y = \frac{54}{x}$

67. $y = \frac{48}{x^2}$ 68. $y = \frac{1}{10} \cdot \frac{xz^2}{w}$ 69. 20 min 70. 75

71. 500 watts 72. A 73. C 74. B 75. Let $f(x)$ and $g(x)$ be odd functions. Then by definition, $f(-x) = -f(x)$, or $f(x) = -f(-x)$, and $g(-x) = -g(x)$, or $g(x) = -g(-x)$. Thus, $(f + g)(x) = f(x) + g(x) = -f(-x) + [-g(-x)] = -[f(-x) + g(-x)] = -(f + g)(-x)$ and $f + g$ is odd.
 76. Reflect the graph of $y = f(x)$ across the x -axis and then across the y -axis. 77. (a) $4x^3 - 2x + 9$;
 (b) $4x^3 + 24x^2 + 46x + 35$; (c) $4x^3 - 2x + 42$. (a) adds 2 to each function value; (b) adds 2 to each input before finding a function value; (c) adds the output for 2 to the output for x 78. In the graph of $y = f(cx)$, the constant c stretches or shrinks the graph of $y = f(x)$ horizontally. The constant c in

$y = cf(x)$ stretches or shrinks the graph of $y = f(x)$ vertically. For $y = f(cx)$, the x -coordinates of $y = f(x)$ are divided by c ; for $y = cf(x)$, the y -coordinates of $y = f(x)$ are multiplied by c . **79.** The graph of $f(x) = 0$ is symmetric with respect to the x -axis, the y -axis, and the origin. This function is both even and odd. **80.** If all the exponents are even numbers, then $f(x)$ is an even function. If $a_0 = 0$ and all the exponents are odd numbers, then $f(x)$ is an odd function. **81.** Let $y(x) = kx^2$. Then $y(2x) = k(2x)^2 = k \cdot 4x^2 = 4 \cdot kx^2 = 4 \cdot y(x)$. Thus doubling x causes y to be quadrupled. **82.** Let $y = k_1x$ and $x = \frac{k_2}{z}$. Then $y = k_1 \cdot \frac{k_2}{z}$,

or $y = \frac{k_1k_2}{z}$, so y varies inversely as z .

Test: Chapter 2

1. [2.1] (a) $(-5, -2)$; (b) $(2, 5)$; (c) $(-2, 2)$
 2. [2.1] Increasing: $(-\infty, 0)$; decreasing: $(0, \infty)$; relative maximum: 2 at $x = 0$ 3. [2.1] $A(b) = \frac{1}{2}b(4b - 6)$, or $2b^2 - 3b$ 4. [2.1]

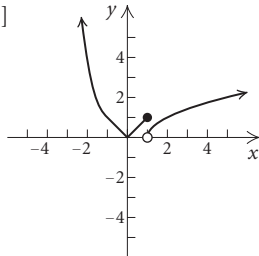

5. [2.1] $f(-\frac{7}{8}) = \frac{7}{8}$; $f(5) = 2$; $f(-4) = 16$
 6. [2.2] 66 7. [2.2] 6 8. [2.2] -1 9. [2.2] 0
 10. [1.2] $(-\infty, \infty)$ 11. [1.2], [1.6] $[3, \infty)$
 12. [2.2] $[3, \infty)$ 13. [2.2] $[3, \infty)$ 14. [2.2] $[3, \infty)$
 15. [2.2] $(3, \infty)$ 16. [2.2] $(f + g)(x) = x^2 + \sqrt{x - 3}$
 17. [2.2] $(f - g)(x) = x^2 - \sqrt{x - 3}$
 18. [2.2] $(fg)(x) = x^2\sqrt{x - 3}$
 19. [2.2] $(f/g)(x) = \frac{x^2}{\sqrt{x - 3}}$ 20. [2.2] $\frac{1}{2}$
 21. [2.2] $4x + 2h - 1$ 22. [2.3] 83 23. [2.3] 0
 24. [2.3] 4 25. [2.3] $16x + 15$
 26. [2.3] $(f \circ g)(x) = \sqrt{x^2 - 4}$; $(g \circ f)(x) = x - 4$
 27. [2.3] Domain of $(f \circ g)(x)$: $(-\infty, -2] \cup [2, \infty)$; domain of $(g \circ f)(x)$: $[5, \infty)$ 28. [2.3] $f(x) = x^4$; $g(x) = 2x - 7$; answers may vary 29. [2.4] x -axis: no; y -axis: yes; origin: no 30. [2.4] Odd
 31. [2.4] $f(x) = (x - 2)^2 - 1$
 32. [2.4] $f(x) = (x + 2)^2 - 3$
 33. [2.4]

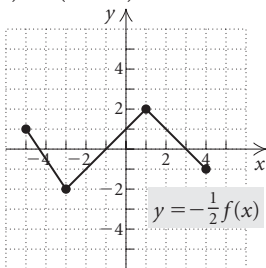

34. [2.5] $y = \frac{30}{x}$ 35. [2.5] $y = 5x$ 36. [2.5] $y = \frac{50xz^2}{w}$
 37. [2.5] 50 ft 38. [2.4] C 39. [2.4] $(-1, 1)$

Chapter 3

Exercise Set 3.1

1. $\sqrt{3}i$ 3. $5i$ 5. $-\sqrt{33}i$ 7. $-9i$ 9. $7\sqrt{2}i$
 11. $2 + 11i$ 13. $5 - 12i$ 15. $4 + 8i$ 17. $-4 - 2i$
 19. $5 + 9i$ 21. $5 + 4i$ 23. $5 + 7i$ 25. $11 - 5i$
 27. $-1 + 5i$ 29. $2 - 12i$ 31. -12 33. -45
 35. $35 + 14i$ 37. $6 + 16i$ 39. $13 - i$ 41. $-11 + 16i$
 43. $-10 + 11i$ 45. $-31 - 34i$ 47. $-14 + 23i$
 49. 41 51. 13 53. 74 55. $12 + 16i$
 57. $-45 - 28i$ 59. $-8 - 6i$ 61. $2i$ 63. $-7 + 24i$
 65. $\frac{15}{146} + \frac{33}{146}i$ 67. $\frac{10}{13} - \frac{15}{13}i$ 69. $-\frac{14}{13} + \frac{5}{13}i$
 71. $\frac{11}{25} - \frac{27}{25}i$ 73. $\frac{-4\sqrt{3} + 10}{41} + \frac{5\sqrt{3} + 8}{41}i$
 75. $-\frac{1}{2} + \frac{1}{2}i$ 77. $-\frac{1}{2} - \frac{13}{2}i$ 79. $-i$ 81. $-i$ 83. 1
 85. i 87. 625 89. [1.4] $y = -2x + 1$ 90. [2.2] All real numbers, or $(-\infty, \infty)$ 91. [2.2] $(-\infty, -\frac{5}{3}) \cup (-\frac{5}{3}, \infty)$
 92. [2.2] $x^2 - 3x - 1$ 93. [2.2] $\frac{8}{11}$ 94. [2.2] $2x + h - 3$
 95. True 97. True 99. $a^2 + b^2$ 101. $x^2 - 6x + 25$

Exercise Set 3.2

1. $\frac{2}{3}, \frac{3}{2}$ 3. $-2, 10$ 5. $-1, \frac{2}{3}$ 7. $-\sqrt{3}, \sqrt{3}$
 9. $-\sqrt{7}, \sqrt{7}$ 11. $-\sqrt{2}i, \sqrt{2}i$ 13. $-4i, 4i$ 15. 0, 3
 17. $-\frac{1}{3}, 0, 2$ 19. $-1, -\frac{1}{7}, 1$ 21. (a) $(-4, 0), (2, 0)$; (b) $-4, 2$ 23. (a) $(-1, 0), (3, 0)$; (b) $-1, 3$
 25. (a) $(-2, 0), (2, 0)$; (b) $-2, 2$ 27. (a) $(1, 0)$; (b) 1 29. $-7, 1$ 31. $4 \pm \sqrt{7}$ 33. $-4 \pm 3i$
 35. $-2, \frac{1}{3}$ 37. $-3, 5$ 39. $-1, \frac{2}{5}$ 41. $\frac{5 \pm \sqrt{7}}{3}$
 43. $-\frac{1}{2} \pm \frac{\sqrt{7}}{2}i$ 45. $\frac{4 \pm \sqrt{31}}{5}$ 47. $\frac{5}{6} \pm \frac{\sqrt{23}}{6}i$
 49. $4 \pm \sqrt{11}$ 51. $\frac{-1 \pm \sqrt{61}}{6}$ 53. $\frac{5 \pm \sqrt{17}}{4}$
 55. $-\frac{1}{5} \pm \frac{3}{5}i$ 57. 144; two real 59. -7 ; two imaginary
 61. 0; one real 63. $-5, -1$ 65. $\frac{3 \pm \sqrt{21}}{2}$; $-0.791, 3.791$
 67. $\frac{5 \pm \sqrt{21}}{2}$; 0.209, 4.791 69. $-1 \pm \sqrt{6}$; $-3.449, 1.449$
 71. $\frac{1}{4} \pm \frac{\sqrt{31}}{4}i$ 73. $\frac{1 \pm \sqrt{13}}{6}$; $-0.434, 0.768$
 75. $\frac{1 \pm \sqrt{6}}{5}$; $-0.290, 0.690$ 77. $\frac{-3 \pm \sqrt{57}}{8}$; $-1.319, 0.569$
 79. $\pm 1, \pm \sqrt{2}$ 81. $\pm \sqrt{2}, \pm \sqrt{5}i$ 83. $\pm 1, \pm \sqrt{5}i$
 85. 16 87. $-8, 64$ 89. 1, 16 91. $\frac{5}{2}, 3$
 93. $-\frac{3}{2}, -1, \frac{1}{2}, 1$ 95. 1995 97. 1997 99. About 10.216 sec 101. Length: 4 ft; width: 3 ft 103. 4 and 9; -9 and -4 105. 2 cm 107. Length: 8 ft; width: 6 ft
 109. Linear 111. Quadratic 113. Linear

115. [1.2] \$16.68 billion 116. [1.2] About 12 yr after 2004, or in 2016 117. [2.4] x -axis: yes; y -axis: yes; origin: yes
 118. [2.4] x -axis: no; y -axis: yes; origin: no 119. [2.4] Odd
 120. [2.4] Neither 121. (a) 2; (b) $\frac{11}{2}$ 123. (a) 2;
 (b) $1 - i$ 125. 1 127. $-\sqrt{7}, -\frac{3}{2}, 0, \frac{1}{3}, \sqrt{7}$
 129. $\frac{-1 \pm \sqrt{1 + 4\sqrt{2}}}{2}$ 131. $3 \pm \sqrt{5}$ 133. 19

135. $-2 \pm \sqrt{2}, \frac{1}{2} \pm \frac{\sqrt{7}}{2}i$

Visualizing the Graph

1. C 2. B 3. A 4. J 5. F 6. D 7. I 8. G
 9. H 10. E

Exercise Set 3.3

1. (a) $(-\frac{1}{2}, -\frac{9}{4})$; (b) $x = -\frac{1}{2}$; (c) minimum: $-\frac{9}{4}$
 3. (a) $(4, -4)$; (b) $x = 4$; (c) minimum: -4 ;
 (d)

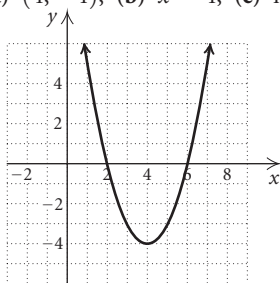

$$f(x) = x^2 - 8x + 12$$

5. (a) $(\frac{7}{2}, -\frac{1}{4})$; (b) $x = \frac{7}{2}$; (c) minimum: $-\frac{1}{4}$;
 (d)

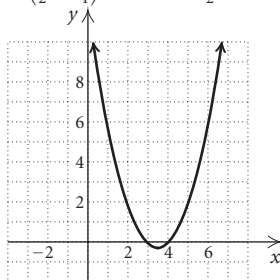

$$f(x) = x^2 - 7x + 12$$

7. (a) $(-2, 1)$; (b) $x = -2$; (c) minimum: 1;
 (d)

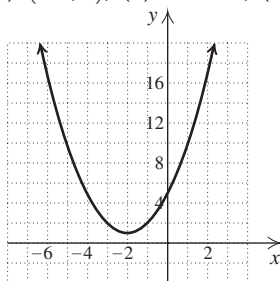

$$f(x) = x^2 + 4x + 5$$

9. (a) $(-4, -2)$; (b) $x = -4$; (c) minimum: -2 ;
 (d)

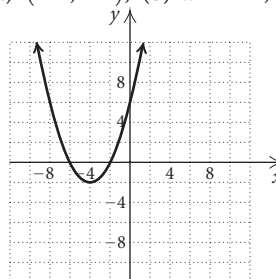

$$g(x) = \frac{x^2}{2} + 4x + 6$$

11. (a) $(-\frac{3}{2}, \frac{7}{2})$; (b) $x = -\frac{3}{2}$; (c) minimum: $\frac{7}{2}$;
 (d)

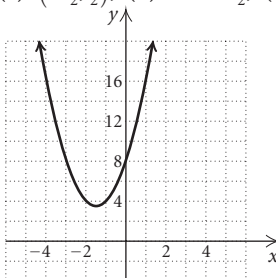

$$g(x) = 2x^2 + 6x + 8$$

13. (a) $(-3, 12)$; (b) $x = -3$; (c) maximum: 12;
 (d)

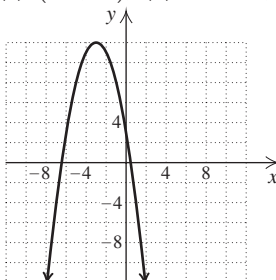

$$f(x) = -x^2 - 6x + 3$$

15. (a) $(\frac{1}{2}, \frac{3}{2})$; (b) $x = \frac{1}{2}$; (c) maximum: $\frac{3}{2}$;
 (d)

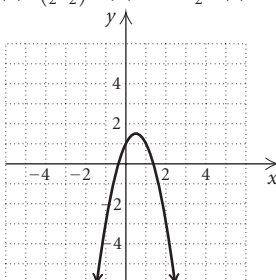

$$g(x) = -2x^2 + 2x + 1$$

17. (f) 19. (b) 21. (h) 23. (c) 25. True
 27. False 29. True 31. (a) $(3, -4)$; (b) minimum: -4 ; (c) $[-4, \infty)$; (d) increasing: $(3, \infty)$; decreasing: $(-\infty, 3)$ 33. (a) $(-1, -18)$; (b) minimum: -18 ; (c) $[-18, \infty)$; (d) increasing: $(-1, \infty)$; decreasing: $(-\infty, -1)$ 35. (a) $(5, \frac{9}{2})$; (b) maximum: $\frac{9}{2}$; (c) $(-\infty, \frac{9}{2}]$; (d) increasing: $(-\infty, 5)$; decreasing: $(5, \infty)$
 37. (a) $(-1, 2)$; (b) minimum: 2 ; (c) $[2, \infty)$; (d) increasing: $(-1, \infty)$; decreasing: $(-\infty, -1)$
 39. (a) $(-\frac{3}{2}, 18)$; (b) maximum: 18 ; (c) $(-\infty, 18]$; (d) increasing: $(-\infty, -\frac{3}{2})$; decreasing: $(-\frac{3}{2}, \infty)$
 41. 0.625 sec; 12.25 ft 43. 3.75 sec; 305 ft 45. 4.5 in.
 47. Base: 10 cm; height: 10 cm 49. 350 chairs
 51. \$797; 40 units 53. 4800 yd² 55. 350.6 ft
 57. $[2.2] 3$ 58. $[2.2] 4x + 2h - 1$

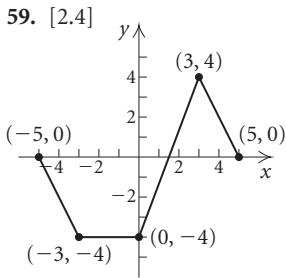

$g(x) = -2f(x)$

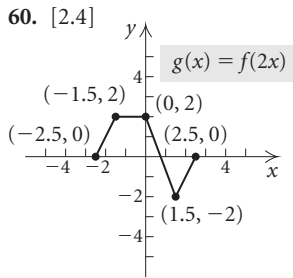

61. -236.25

63. $f(x) = (|x| - 5)^2 - 3$

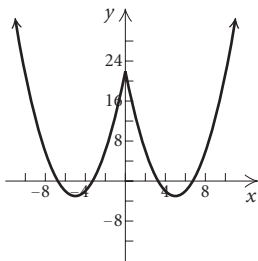

65. Pieces should be $\frac{24\pi}{4 + \pi}$ in. and $\frac{96}{4 + \pi}$ in.

Mid-Chapter Mixed Review: Chapter 3

1. True 2. False 3. True 4. False 5. $6i$ 6. $\sqrt{5}i$
 7. $-4i$ 8. $4\sqrt{2}i$ 9. $-1 + i$ 10. $-7 + 5i$
 11. $23 + 2i$ 12. $-\frac{1}{29} - \frac{17}{29}i$ 13. i 14. 1 15. $-i$
 16. -64 17. $-4, 1$ 18. $-2, -\frac{3}{2}$ 19. $\pm\sqrt{6}$
 20. $\pm 10i$ 21. $4x^2 - 8x - 3 = 0; 4x^2 - 8x = 3;$
 $x^2 - 2x = \frac{3}{4}; x^2 - 2x + 1 = \frac{3}{4} + 1; (x - 1)^2 = \frac{7}{4}$
 $x - 1 = \pm \frac{\sqrt{7}}{2}; x = 1 \pm \frac{\sqrt{7}}{2} = \frac{2 \pm \sqrt{7}}{2}$
 22. (a) 29; two real; (b) $\frac{3 \pm \sqrt{29}}{2}; -1.193, 4.193$
 23. (a) 0; one real; (b) $\frac{3}{2}$ 24. (a) -8 ; two nonreal;

(b) $-\frac{1}{3} \pm \frac{\sqrt{2}}{3}i$ 25. $\pm 1, \pm \sqrt{6}i$ 26. $\frac{1}{4}, 4$

27. 5 and 7; -7 and -5 28. (a) $(3, -2)$; (b) $x = 3$; (c) minimum: -2 ; (d) $[-2, \infty)$; (e) increasing: $(3, \infty)$; decreasing: $(-\infty, 3)$; (f)

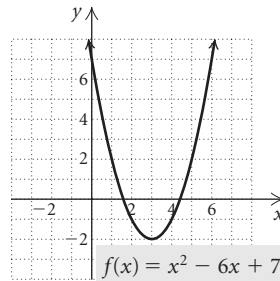

29. (a) $(-1, -3)$; (b) $x = -1$; (c) maximum: -3 ; (d) $(-\infty, -3]$; (e) increasing: $(-\infty, -1)$; decreasing: $(-1, \infty)$; (f)

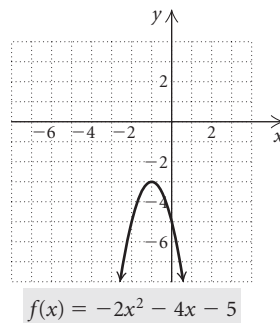





30. Base: 8 in., height: 8 in. 31. The sum of two imaginary numbers is not always an imaginary number. For example, $(2 + i) + (3 - i) = 5$, a real number. 32. Use the discriminant. If $b^2 - 4ac < 0$, there are no x -intercepts. If $b^2 - 4ac = 0$, there is one x -intercept. If $b^2 - 4ac > 0$, there are two x -intercepts. 33. Completing the square was used in Section 3.2 to solve quadratic equations. It was used again in Section 3.3 to write quadratic functions in the form $f(x) = a(x - h)^2 + k$. 34. The x -intercepts of $g(x)$ are also $(x_1, 0)$ and $(x_2, 0)$. This is true because $f(x)$ and $g(x)$ have the same zeros. Consider $g(x) = 0$, or $-ax^2 - bx - c = 0$. Multiplying by -1 on both sides, we get an equivalent equation $ax^2 + bx + c = 0$, or $f(x) = 0$.

Exercise Set 3.4

1. $\frac{20}{9}$ 3. 286 5. 6 7. 6 9. 2, 3 11. $-1, 6$
 13. $\frac{1}{2}, 5$ 15. 7 17. No solution 19. $-\frac{69}{14}$ 21. $-\frac{37}{18}$
 23. 2 25. No solution 27. $\{x \mid x \text{ is a real number and } x \neq 0 \text{ and } x \neq 6\}$ 29. $\frac{5}{3}$ 31. $\frac{9}{2}$ 33. 3 35. -4
 37. -5 39. $\pm\sqrt{2}$ 41. No solution 43. 6
 45. -1 47. $\frac{35}{2}$ 49. -98 51. -6 53. 5 55. 7
 57. 2 59. $-1, 2$ 61. 7 63. 7 65. No solution
 67. 1 69. 3, 7 71. 5 73. -1 75. -8 77. 81
 79. $T_1 = \frac{P_1 V_1 T_2}{P_2 V_2}$ 81. $C = \frac{1}{LW^2}$ 83. $R_2 = \frac{RR_1}{R_1 - R}$

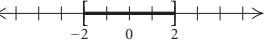
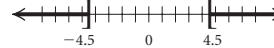
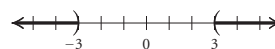
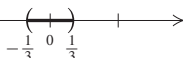
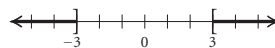
85. $P = \frac{A}{I^2 + 2I + 1}$, or $\frac{A}{(I + 1)^2}$ 87. $p = \frac{Fm}{m - F}$
 89. [1.5] 7.5 90. [1.5] 3 91. [1.5] About 4975 fatalities
 92. [1.5] Mall of America: 96 acres; Disneyland: 85 acres
 93. $3 \pm 2\sqrt{2}$ 95. -1 97. 0, 1

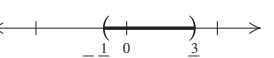
Exercise Set 3.5

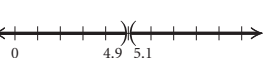
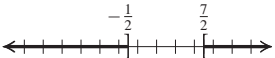
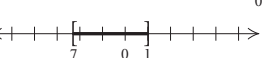
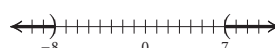
1. -7, 7 3. 0 5. $-\frac{5}{6}, \frac{5}{6}$ 7. No solution 9. $-\frac{1}{3}, \frac{1}{3}$
 11. -3, 3 13. -3, 5 15. -8, 4 17. -1, $-\frac{1}{3}$
 19. -24, 44 21. -2, 4 23. -13, 7 25. $-\frac{4}{3}, \frac{2}{3}$
 27. $-\frac{3}{4}, \frac{9}{4}$ 29. -13, 1 31. 0, 1
 33. $(-7, 7)$; 
 35. $[-2, 2]$; 
 37. $(-\infty, -4.5] \cup [4.5, \infty)$; 
 39. $(-\infty, -3) \cup (3, \infty)$; 
 41. $(-\frac{1}{3}, \frac{1}{3})$; 
 43. $(-\infty, -3] \cup [3, \infty)$; 
 45. $(-17, 1)$; 
 47. $(-\infty, -17] \cup [1, \infty)$; 
 49. $(-\frac{1}{4}, \frac{3}{4})$; 
 51. $[-6, 3]$; 
 53. $(-\infty, 4.9) \cup (5.1, \infty)$; 
 55. $(-\infty, -\frac{1}{2}] \cup [\frac{7}{2}, \infty)$; 
 57. $[-\frac{7}{3}, 1]$; 
 59. $(-\infty, -8) \cup (7, \infty)$; 
 61. No solution 63. [1.1] y-intercept 64. [1.1] Distance formula
 65. [1.2] Relation 66. [1.2] Function
 67. [1.3] Horizontal lines 68. [1.4] Parallel
 69. [2.1] Decreasing 70. [2.4] Symmetric with respect to the y-axis
 71. $(-\infty, \frac{1}{2})$ 73. No solution
 75. $(-\infty, -\frac{8}{3}) \cup (-2, \infty)$

Review Exercises: Chapter 3

1. True 2. True 3. False 4. False 5. $-\frac{5}{2}, \frac{1}{3}$
 6. -5, 1 7. $-2, \frac{4}{3}$ 8. $-\sqrt{3}, \sqrt{3}$ 9. $-\sqrt{10}i, \sqrt{10}i$
 10. 1 11. -5, 3 12. $\frac{1 \pm \sqrt{41}}{4}$ 13. $-\frac{1}{3} \pm \frac{2\sqrt{2}}{3}i$
 14. $\frac{27}{7}$ 15. $-\frac{1}{2}, \frac{9}{4}$ 16. 0, 3 17. 5 18. 1, 7 19. -8, 1

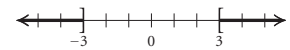
20. $(-\infty, -3] \cup [3, \infty)$; 

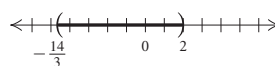
21. $(-\frac{14}{3}, 2)$; 

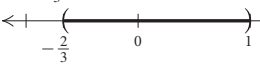
22. $(-\frac{2}{3}, 1)$; 

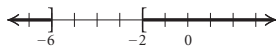
23. $(-\infty, -6] \cup [-2, \infty)$; 

24. $P = \frac{MN}{M + N}$ 25. $-2\sqrt{10}i$ 26. $-4\sqrt{15}$

27. $-\frac{7}{8}$ 28. $2 - i$ 29. $1 - 4i$ 30. $-18 - 26i$

31. $\frac{11}{10} + \frac{3}{10}i$ 32. $-i$ 33. $x^2 - 3x + \frac{9}{4} = 18 + \frac{9}{4}$;

$(x - \frac{3}{2})^2 = \frac{81}{4}$; $x = \frac{3}{2} \pm \frac{9}{2}$; -3, 6 34. $x^2 - 4x = 2$;

$x^2 - 4x + 4 = 2 + 4$; $(x - 2)^2 = 6$; $x = 2 \pm \sqrt{6}$;

$2 - \sqrt{6}, 2 + \sqrt{6}$ 35. $-4, \frac{2}{3}$ 36. $1 - 3i, 1 + 3i$

37. -2, 5 38. 1 39. $\pm \sqrt{\frac{3 \pm \sqrt{5}}{2}}$ 40. $-\sqrt{3}, 0, \sqrt{3}$

41. $-2, -\frac{2}{3}, 3$ 42. -5, -2, 2 43. (a) $(\frac{3}{8}, -\frac{7}{16})$;

(b) $x = \frac{3}{8}$; (c) maximum: $-\frac{7}{16}$; (d) $(-\infty, -\frac{7}{16}]$;

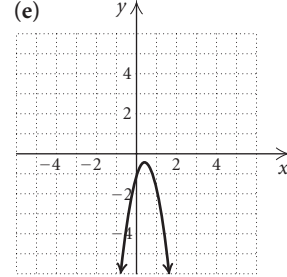

$f(x) = -4x^2 + 3x - 1$

44. (a) (1, -2); (b) $x = 1$; (c) minimum: -2;
 (d) $[-2, \infty)$; (e)

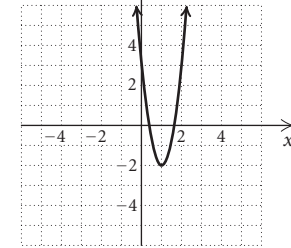

$f(x) = 5x^2 - 10x + 3$

45. (d) 46. (c) 47. (b) 48. (a) 49. 30 ft, 40 ft
 50. Cassidy: 15 km/h; Logan: 8 km/h 51. $35 - 5\sqrt{33}$ ft,
 or about 6.3 ft 52. 6 ft by 6 ft 53. $\frac{15 - \sqrt{115}}{2}$ cm, or
 about 2.1 cm 54. B 55. B 56. A 57. 256
 58. $4 \pm \sqrt[4]{243}$, or 0.052, 7.948 59. -7, 9 60. $-\frac{1}{4}, 2$
 61. -1 62. 9% 63. ± 6 64. The product of two
 imaginary numbers is not always an imaginary number.
 For example, $i \cdot i = i^2 = -1$, a real number. 65. No;
 consider the quadratic formula $x = \frac{-b \pm \sqrt{b^2 - 4ac}}{2a}$.

If $b^2 - 4ac = 0$, then $x = \frac{-b}{2a}$, so there is one real zero.

If $b^2 - 4ac > 0$, then $\sqrt{b^2 - 4ac}$ is a real number and there are two real zeros. If $b^2 - 4ac < 0$, then $\sqrt{b^2 - 4ac}$ is an imaginary number and there are two imaginary zeros. Thus a quadratic function cannot have one real zero and one imaginary zero. **66.** You can conclude that $|a_1| = |a_2|$ since these constants determine how wide the parabolas are. Nothing can be concluded about the h 's and the k 's. **67.** When both sides of an equation are multiplied by the LCD, the resulting equation might not be equivalent to the original equation. One or more of the possible solutions of the resulting equation might make a denominator of the original equation 0. **68.** When both sides of an equation are raised to an even power, the resulting equation might not be equivalent to the original equation. For example, the solution set of $x = -2$ is $\{-2\}$, but the solution set of $x^2 = (-2)^2$, or $x^2 = 4$, is $\{-2, 2\}$. **69.** Absolute value is nonnegative. **70.** $|x| \geq 0 > p$ for any real number x .

Test: Chapter 3

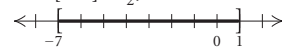
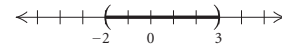
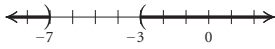
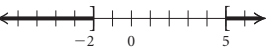
1. [3.2] $\frac{1}{2}, -5$ 2. [3.2] $-\sqrt{6}, \sqrt{6}$ 3. [3.2] $-2i, 2i$
 4. [3.2] $-1, 3$ 5. [3.2] $\frac{5 \pm \sqrt{13}}{2}$ 6. [3.2] $\frac{3}{4} \pm \frac{\sqrt{23}}{4}i$
 7. [3.2] 16 8. [3.4] $-1, \frac{13}{6}$ 9. [3.4] 5 10. [3.4] 5
 11. [3.5] $-11, 3$ 12. [3.5] $-\frac{1}{2}, 2$
 13. [3.5] $[-7, 1]$; 
 14. [3.5] $(-2, 3)$; 
 15. [3.5] $(-\infty, -7) \cup (-3, \infty)$; 
 16. [3.5] $(-\infty, -2] \cup [5, \infty)$; 
 17. [3.4] $B = \frac{AC}{A - C}$ 18. [3.4] $n = \frac{R^2}{3p}$
 19. [3.2] $x^2 + 4x = 1$; $x^2 + 4x + 4 = 1 + 4$; $(x + 2)^2 = 5$;
 $x = -2 \pm \sqrt{5}$; $-2 - \sqrt{5}, -2 + \sqrt{5}$ 20. [3.2] About
 11.4 sec 21. [3.1] $\sqrt{43}i$ 22. [3.1] $-5i$
 23. [3.1] $3 - 5i$ 24. [3.1] $10 + 5i$ 25. [3.1] $\frac{1}{10} - \frac{1}{5}i$
 26. [3.1] i 27. [3.2] $-\frac{1}{4}, 3$ 28. [3.2] $\frac{1 \pm \sqrt{57}}{4}$
 29. [3.3] (a) $(1, 9)$; (b) $x = 1$; (c) maximum: 9;
 (d) $(-\infty, 9]$; (e)

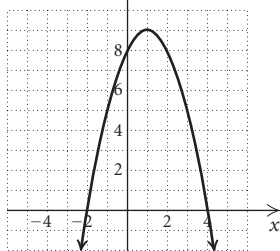

$f(x) = -x^2 + 2x + 8$

30. [3.3] 20 ft by 40 ft 31. [3.3] C 32. [3.3], [3.4] $-\frac{4}{9}$

Chapter 4

Exercise Set 4.1

1. $\frac{1}{2}x^3; \frac{1}{2}, 3$; cubic 3. $0.9x$; 0.9 ; 1; linear 5. $305x^4$; 305; 4;
 quartic 7. x^4 ; 1; 4; quartic 9. $4x^3$; 4; 3; cubic
 11. (d) 13. (b) 15. (c) 17. (a) 19. (c)
 21. (d) 23. Yes; no; no 25. No; yes; yes
 27. -3 , multiplicity 2; 1, multiplicity 1 29. 4, multiplicity 3;
 -6 , multiplicity 1 31. ± 3 , each has multiplicity 3
 33. 0, multiplicity 3; 1, multiplicity 2; -4 , multiplicity 1
 35. 3, multiplicity 2; -4 , multiplicity 3; 0, multiplicity 4
 37. $\pm\sqrt{3}, \pm 1$, each has multiplicity 1 39. $-3, -1, 1$, each
 has multiplicity 1 41. $\pm 2, \frac{1}{2}$, each has multiplicity 1
 43. False 45. True 47. 1995: 98,856; 2005: 134,457
 49. 26, 64, and 80 51. 5 sec 53. 2002: \$159,556; 2005:
 \$214,783; 2008: \$201,015; 2009: \$175,752 55. 6.3% 57. [1.1] 5
 58. [1.1] $6\sqrt{2}$ 59. [1.1] Center: $(3, -5)$; radius: 7
 60. [1.1] Center: $(-4, 3)$; radius: $2\sqrt{2}$ 61. [1.6] $\{y | y \geq 3\}$,
 or $[3, \infty)$ 62. [1.6] $\{x | x > \frac{5}{3}\}$, or $(\frac{5}{3}, \infty)$
 63. [3.5] $\{x | x \leq -13 \text{ or } x \geq 1\}$, or $(-\infty, -13] \cup [1, \infty)$
 64. [3.5] $\{x | -\frac{11}{12} \leq x \leq \frac{5}{12}\}$, or $[-\frac{11}{12}, \frac{5}{12}]$ 65. 16; x^{16}

Visualizing the Graph

1. H 2. D 3. J 4. B 5. A 6. C 7. I
 8. E 9. G 10. F

Exercise Set 4.2

1. (a) 5; (b) 5; (c) 4 3. (a) 10; (b) 10; (c) 9
 5. (a) 3; (b) 3; (c) 2 7. (d) 9. (f) 11. (b)
 13.

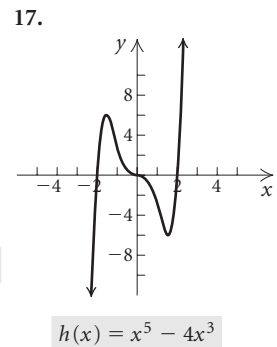
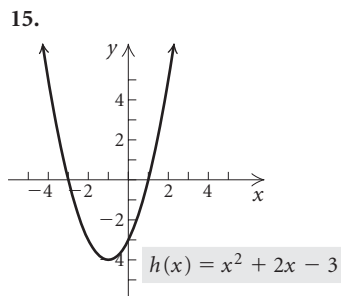
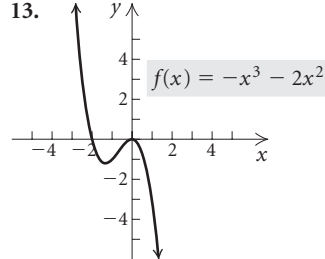

$h(x) = x^5 - 4x^3$

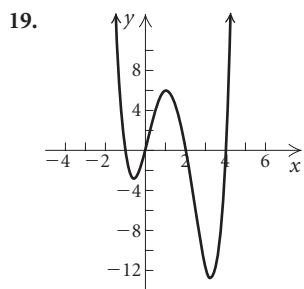

$$h(x) = x(x - 4)(x + 1)(x - 2)$$

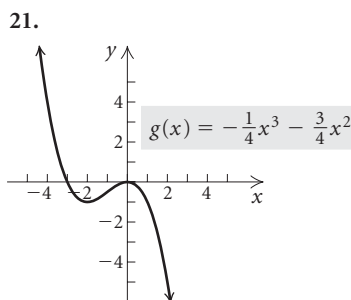

$$g(x) = -\frac{1}{4}x^3 - \frac{3}{4}x^2$$

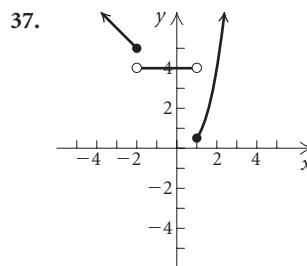

$$g(x) = \begin{cases} -x + 3, & \text{for } x \leq -2, \\ 4, & \text{for } -2 < x < 1, \\ \frac{1}{2}x^3, & \text{for } x \geq 1 \end{cases}$$

39. $f(-5) = -18$ and $f(-4) = 7$. By the intermediate value theorem, since $f(-5)$ and $f(-4)$ have opposite signs, then $f(x)$ has a zero between -5 and -4 .

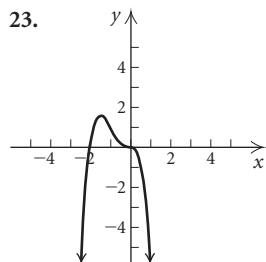

$$g(x) = -x^4 - 2x^3$$

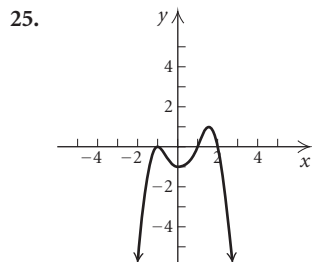

$$f(x) = -\frac{1}{2}(x - 2)(x + 1)^2(x - 1)$$

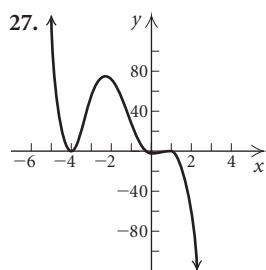

$$g(x) = -x(x - 1)^2(x + 4)^2$$

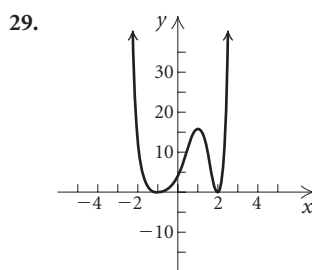

$$f(x) = (x - 2)^2(x + 1)^4$$

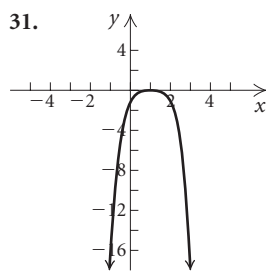

$$g(x) = -(x - 1)^4$$

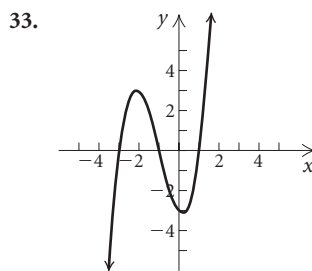

$$h(x) = x^3 + 3x^2 - x - 3$$

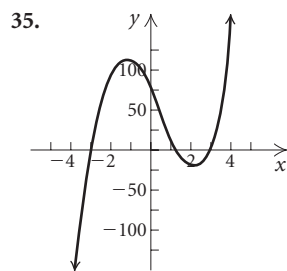

$$f(x) = 6x^3 - 8x^2 - 54x + 72$$

41. $f(-3) = 22$ and $f(-2) = 5$. Both $f(-3)$ and $f(-2)$ are positive. We cannot use the intermediate value theorem to determine if there is a zero between -3 and -2 . 43. $f(2) = 2$ and $f(3) = 57$. Both $f(2)$ and $f(3)$ are positive. We cannot use the intermediate value theorem to determine if there is a zero between 2 and 3 . 45. $f(4) = -12$ and $f(5) = 4$. By the intermediate value theorem, since $f(4)$ and $f(5)$ have opposite signs, then $f(x)$ has a zero between 4 and 5 . 47. [1.1] (d) 48. [1.3] (f) 49. [1.1] (e) 50. [1.1] (a) 51. [1.1] (b) 52. [1.3] (c) 53. [1.5] $\frac{9}{10}$ 54. [4.1] $-3, 0, 4$ 55. [3.2] $-\frac{5}{3}, \frac{11}{2}$ 56. [1.5] $\frac{196}{25}$

Exercise Set 4.3

1. (a) No; (b) yes; (c) no 3. (a) Yes; (b) no; (c) yes
 5. $P(x) = (x + 2)(x^2 - 2x + 4) - 16$
 7. $P(x) = (x + 9)(x^2 - 3x + 2) + 0$
 9. $P(x) = (x + 2)(x^3 - 2x^2 + 2x - 4) + 11$
 11. $Q(x) = 2x^3 + x^2 - 3x + 10, R(x) = -42$
 13. $Q(x) = x^2 - 4x + 8, R(x) = -24$
 15. $Q(x) = 3x^2 - 4x + 8, R(x) = -18$
 17. $Q(x) = x^4 + 3x^3 + 10x^2 + 30x + 89, R(x) = 267$
 19. $Q(x) = x^3 + x^2 + x + 1, R(x) = 0$
 21. $Q(x) = 2x^3 + x^2 + \frac{7}{2}x + \frac{7}{4}, R(x) = -\frac{1}{8}$
 23. 0; -60 ; 0 25. 10; 80; 998 27. 5,935,988; -772
 29. 0; 0; 65; $1 - 12\sqrt{2}$ 31. Yes; no 33. Yes; yes
 35. No; yes 37. No; no
 39. $f(x) = (x - 1)(x + 2)(x + 3)$; 1, -2 , -3
 41. $f(x) = (x - 2)(x - 5)(x + 1)$; 2, 5, -1
 43. $f(x) = (x - 2)(x - 3)(x + 4)$; 2, 3, -4
 45. $f(x) = (x - 3)^3(x + 2)$; 3, -2
 47. $f(x) = (x - 1)(x - 2)(x - 3)(x + 5)$; 1, 2, 3, -5
 49.

$$f(x) = x^4 - x^3 - 7x^2 + x + 6$$

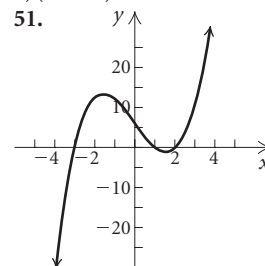

$$f(x) = x^3 - 7x + 6$$

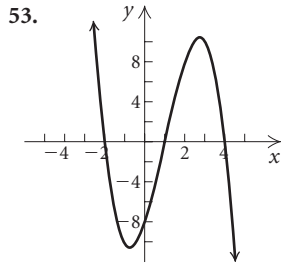

$f(x) = -x^3 + 3x^2 + 6x - 8$

53. 55. [3.2] $\frac{5}{4} \pm \frac{\sqrt{71}}{4}i$
 56. [3.2] $-1, \frac{3}{7}$ 57. [3.2] $-5, 0$ 58. [1.2] 10
 59. [3.2] $-3, -2$ 60. [1.4] $f(x) = 0.1604x + 2.69$; 1998: \$5.58; 2012: \$7.82
 61. [3.2] $b = 15$ in., $h = 15$ in.

Mid-Chapter Mixed Review: Chapter 4

1. False 2. True 3. True 4. False
 5. 5; multiplicity 6 6. $-5, -\frac{1}{2}, 5$; each has multiplicity 1
 7. $\pm 1, \pm\sqrt{2}$; each has multiplicity 1 8. 3, multiplicity 2; -4 , multiplicity 1 9. (d) 10. (a) 11. (b) 12. (c)
 13. $f(-2) = -13$ and $f(0) = 3$. By the intermediate value theorem, since $f(-2)$ and $f(0)$ have opposite signs, then $f(x)$ has at least one zero between -2 and 0 . 14. $f(-\frac{1}{2}) = 2\frac{3}{8}$ and $f(1) = 2$. Both $f(-\frac{1}{2})$ and $f(1)$ are positive. We cannot use the intermediate value theorem to determine if there is a zero between $-\frac{1}{2}$ and 1 .
 15. $P(x) = (x - 1)(x^3 - 5x^2 - 5x - 4) - 6$
 16. $Q(x) = 3x^3 + 5x^2 + 12x + 18, R(x) = 42$
 17. $Q(x) = x^4 - x^3 + x^2 - x + 1, R(x) = -6$
 18. $g(-5) = -380$ 19. $f(\frac{1}{2}) = -15$
 20. $f(-\sqrt{2}) = 20 - \sqrt{2}$ 21. Yes; no 22. Yes; yes
 23. $h(x) = (x - 1)(x - 8)(x + 7); -7, 1, 8$
 24. $g(x) = (x + 1)(x - 2)(x - 4)(x + 3); -3, -1, 2, 4$
 25. The range of a polynomial function with an odd degree is $(-\infty, \infty)$. The range of a polynomial function with an even degree is $[s, \infty)$ for some real number s if $a_n > 0$ and is $(-\infty, s]$ for some real number s if $a_n < 0$. 26. Since we can find $f(0)$ for any polynomial function $f(x)$, it is not possible for the graph of a polynomial function to have no y -intercept. It is possible for a polynomial function to have no x -intercepts. For instance, a function of the form $f(x) = x^2 + a, a > 0$, has no x -intercepts. There are other examples as well.
 27. The zeros of a polynomial function are the first coordinates of the points at which the graph of the function crosses or is tangent to the x -axis. 28. For a polynomial $P(x)$ of degree n , when we have $P(x) = d(x) \cdot Q(x) + R(x)$, where the degree of $d(x)$ is 1, then the degree of $Q(x)$ must be $n - 1$.

Exercise Set 4.4

1. $f(x) = x^3 - 6x^2 - x + 30$
 3. $f(x) = x^3 + 3x^2 + 4x + 12$
 5. $f(x) = x^3 - 3x^2 - 2x + 6$ 7. $f(x) = x^3 - 6x - 4$
 9. $f(x) = x^3 + 2x^2 + 29x + 148$
 11. $f(x) = x^3 - \frac{5}{3}x^2 - \frac{2}{3}x$ 13. $f(x) = x^5 + 2x^4 - 2x^2 - x$
 15. $f(x) = x^4 + 3x^3 + 3x^2 + x$ 17. $-\sqrt{3}$
 19. $i, 2 + \sqrt{5}$ 21. $-3i$ 23. $-4 + 3i, 2 + \sqrt{3}$
 25. $-\sqrt{5}, 4i$ 27. $2 + i$ 29. $-3 - 4i, 4 + \sqrt{5}$
 31. $4 + i$ 33. $f(x) = x^3 - 4x^2 + 6x - 4$
 35. $f(x) = x^2 + 16$ 37. $f(x) = x^3 - 5x^2 + 16x - 80$
 39. $f(x) = x^4 - 2x^3 - 3x^2 + 10x - 10$
 41. $f(x) = x^4 + 4x^2 - 45$ 43. $-\sqrt{2}, \sqrt{2}$
 45. $i, 2, 3$ 47. $1 + 2i, 1 - 2i$ 49. ± 1
 51. $\pm 1, \pm \frac{1}{2}, \pm 2, \pm 4, \pm 8$ 53. $\pm 1, \pm 2, \pm \frac{1}{3}, \pm \frac{1}{5}, \pm \frac{2}{3}, \pm \frac{2}{5}, \pm \frac{1}{15}, \pm \frac{2}{15}$ 55. (a) Rational: -3 ; other: $\pm\sqrt{2}$;
 (b) $f(x) = (x + 3)(x + \sqrt{2})(x - \sqrt{2})$
 57. (a) Rational: $\frac{1}{3}$; other: $\pm\sqrt{5}$;
 (b) $f(x) = 3(x - \frac{1}{3})(x + \sqrt{5})(x - \sqrt{5})$
 59. (a) Rational: $-2, 1$; other: none;
 (b) $f(x) = (x + 2)(x - 1)^2$ 61. (a) Rational: $-\frac{3}{2}$;
 other: $\pm 3i$; (b) $f(x) = 2(x + \frac{3}{2})(x + 3i)(x - 3i)$
 63. (a) Rational: $-\frac{1}{5}, 1$; other: $\pm 2i$;
 (b) $f(x) = 5(x + \frac{1}{5})(x - 1)(x + 2i)(x - 2i)$,
 or $(5x + 1)(x - 1)(x + 2i)(x - 2i)$
 65. (a) Rational: $-2, -1$; other: $3 \pm \sqrt{13}$;
 (b) $f(x) = (x + 2)(x + 1)(x - 3 - \sqrt{13})(x - 3 + \sqrt{13})$
 67. (a) Rational: 2; other: $1 \pm \sqrt{3}$;
 (b) $f(x) = (x - 2)(x - 1 - \sqrt{3})(x - 1 + \sqrt{3})$
 69. (a) Rational: -2 ; other: $1 \pm \sqrt{3}i$;
 (b) $f(x) = (x + 2)(x - 1 - \sqrt{3}i)(x - 1 + \sqrt{3}i)$
 71. (a) Rational: $\frac{1}{2}$; other: $\frac{1 \pm \sqrt{5}}{2}$;

(b) $f(x) = \frac{1}{3}(x - \frac{1}{2})(x - \frac{1 + \sqrt{5}}{2})(x - \frac{1 - \sqrt{5}}{2})$

73. 1, -3 75. No rational zeros 77. No rational zeros
 79. $-2, 1, 2$ 81. 3 or 1; 0 83. 0; 3 or 1 85. 2 or 0;
 2 or 0 87. 1; 1 89. 1; 0 91. 2 or 0; 2 or 0
 93. 3 or 1; 1 95. 1; 1
 97.

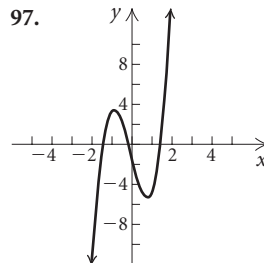

$f(x) = 4x^3 + x^2 - 8x - 2$

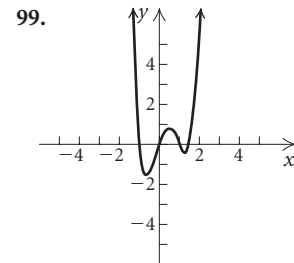

$f(x) = 2x^4 - 3x^3 - 2x^2 + 3x$

101. [3.3] (a) $(4, -6)$; (b) $x = 4$; (c) minimum: -6 at $x = 4$ 102. [3.3] (a) $(1, -4)$; (b) $x = 1$; (c) minimum: -4 at $x = 1$ 103. [1.5] 10
 104. [3.2] $-3, 11$ 105. [4.1] Cubic; $-x^3; -1; 3$; as $x \rightarrow \infty, g(x) \rightarrow -\infty$, and as $x \rightarrow -\infty, g(x) \rightarrow \infty$
 106. [3.3] Quadratic; $-x^2; -1; 2$; as $x \rightarrow \infty, f(x) \rightarrow -\infty$, and as $x \rightarrow -\infty, f(x) \rightarrow -\infty$ 107. [1.3] Constant; $-\frac{4}{9}; -\frac{4}{9}$; zero degree; for all $x, f(x) = -\frac{4}{9}$ 108. [1.3] Linear; $x; 1$; as $x \rightarrow \infty, h(x) \rightarrow \infty$, and as $x \rightarrow -\infty, h(x) \rightarrow -\infty$
 109. [4.1] Quartic; $x^4; 1; 4$; as $x \rightarrow \infty, g(x) \rightarrow \infty$, and as $x \rightarrow -\infty, g(x) \rightarrow \infty$ 110. [4.1] Cubic; $x^3; 1; 3$; as $x \rightarrow \infty, h(x) \rightarrow \infty$, and as $x \rightarrow -\infty, h(x) \rightarrow -\infty$
 111. (a) $-1, \frac{1}{2}, 3$; (b) $0, \frac{3}{2}, 4$; (c) $-3, -\frac{3}{2}, 1$; (d) $-\frac{1}{2}, \frac{1}{4}, \frac{3}{2}$
 113. $-8, -\frac{3}{2}, 4, 7, 15$

Visualizing the Graph

1. A 2. C 3. D 4. H 5. G 6. F 7. B
 8. I 9. J 10. E

Exercise Set 4.5

1. $\{x \mid x \neq 2\}$, or $(-\infty, 2) \cup (2, \infty)$
 3. $\{x \mid x \neq 1 \text{ and } x \neq 5\}$, or $(-\infty, 1) \cup (1, 5) \cup (5, \infty)$
 5. $\{x \mid x \neq -5\}$, or $(-\infty, -5) \cup (-5, \infty)$
 7. (d); $x = 2, x = -2, y = 0$ 9. (e); $x = 2, x = -2, y = 0$ 11. (c); $x = 2, x = -2, y = 8x$ 13. $x = 0$
 15. $x = 2$ 17. $x = 4, x = -6$ 19. $x = \frac{3}{2}, x = -1$
 21. $y = \frac{3}{4}$ 23. $y = 0$ 25. No horizontal asymptote
 27. $y = x + 1$ 29. $y = x$ 31. $y = x - 3$
 33. Domain: $(-\infty, 0) \cup (0, \infty)$; no x -intercepts, no y -intercept;

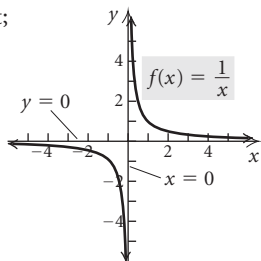

35. Domain: $(-\infty, 0) \cup (0, \infty)$; no x -intercepts, no y -intercept;

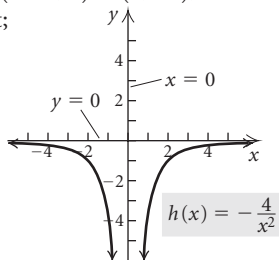

37. Domain: $(-\infty, -1) \cup (-1, \infty)$; x -intercepts: $(1, 0)$ and $(3, 0)$; y -intercept: $(0, 3)$;

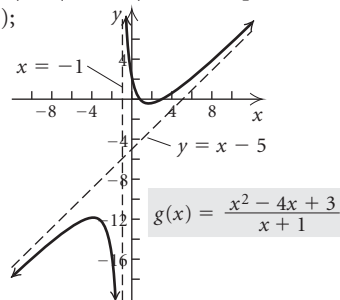

39. Domain: $(-\infty, 5) \cup (5, \infty)$; no x -intercepts, y -intercept: $(0, \frac{2}{5})$;

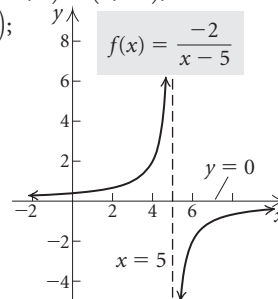

41. Domain: $(-\infty, 0) \cup (0, \infty)$; x -intercept: $(-\frac{1}{2}, 0)$, no y -intercept;

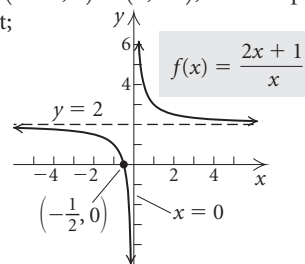

43. Domain: $(-\infty, -3) \cup (-3, 3) \cup (3, \infty)$; no x -intercepts, y -intercept: $(0, -\frac{1}{3})$;

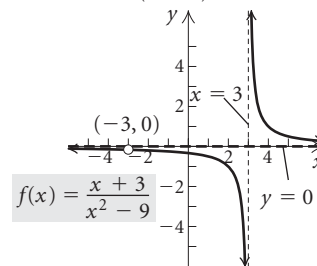

45. Domain: $(-\infty, -3) \cup (-3, 0) \cup (0, \infty)$; no x -intercepts, no y -intercept;

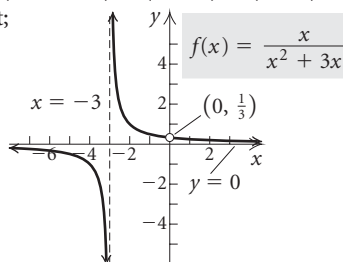

47. Domain: $(-\infty, 2) \cup (2, \infty)$; no x -intercepts, y -intercept: $(0, \frac{1}{4})$;

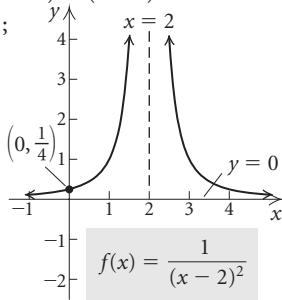

49. Domain: $(-\infty, -3) \cup (-3, -1) \cup (-1, \infty)$; x -intercept: $(1, 0)$, y -intercept: $(0, -1)$;

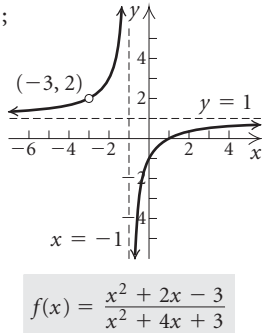

51. Domain: $(-\infty, \infty)$; no x -intercepts, y -intercept: $(0, \frac{1}{3})$;

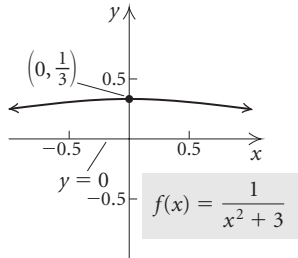

53. Domain: $(-\infty, 2) \cup (2, \infty)$; x -intercept: $(-2, 0)$, y -intercept: $(0, 2)$;

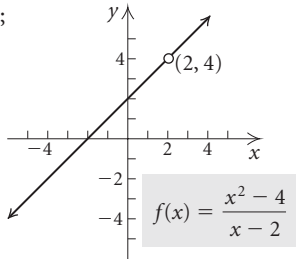

55. Domain: $(-\infty, -2) \cup (-2, \infty)$; x -intercept: $(1, 0)$, y -intercept: $(0, -\frac{1}{2})$;

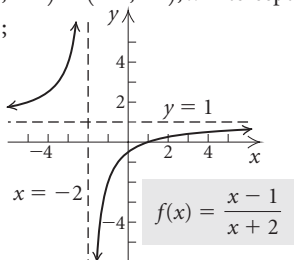

57. Domain: $(-\infty, -\frac{1}{2}) \cup (-\frac{1}{2}, 0) \cup (0, 3) \cup (3, \infty)$; x -intercept: $(-3, 0)$, no y -intercept;

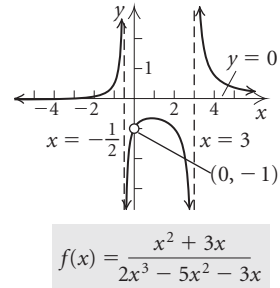

59. Domain: $(-\infty, -1) \cup (-1, \infty)$; x -intercepts: $(-3, 0)$ and $(3, 0)$, y -intercept: $(0, -9)$;

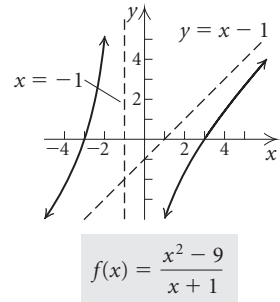

61. Domain: $(-\infty, \infty)$; x -intercepts: $(-2, 0)$ and $(1, 0)$, y -intercept: $(0, -2)$;

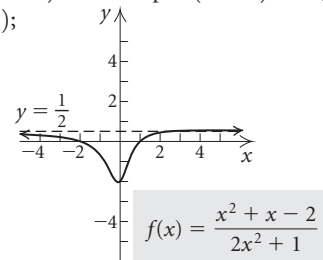

63. Domain: $(-\infty, 1) \cup (1, \infty)$; x -intercept: $(-\frac{2}{3}, 0)$, y -intercept: $(0, 2)$;

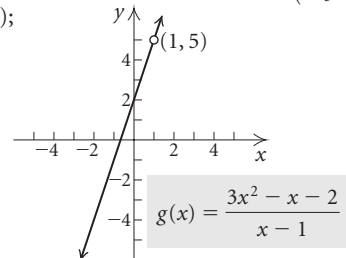

65. Domain: $(-\infty, -1) \cup (-1, 3) \cup (3, \infty)$;
 x-intercept: $(1, 0)$, y-intercept: $(0, \frac{1}{3})$;

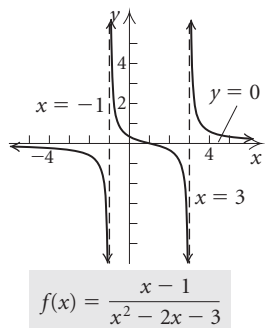

67. Domain: $(-\infty, -4) \cup (-4, 2) \cup (2, \infty)$;
 x-intercept: $(\frac{1}{3}, 0)$, y-intercept: $(0, \frac{1}{2})$;

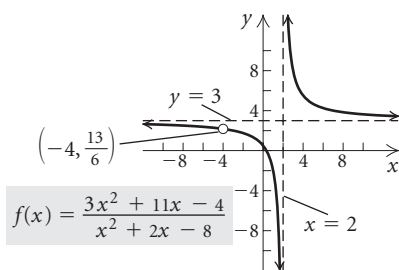

69. Domain: $(-\infty, -1) \cup (-1, \infty)$; x-intercept: $(3, 0)$,
 y-intercept: $(0, -3)$;

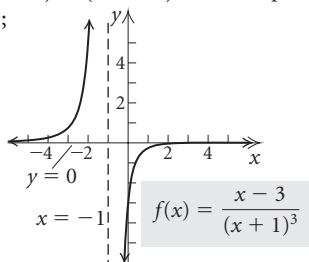

71. Domain: $(-\infty, 0) \cup (0, \infty)$; x-intercept: $(-1, 0)$,
 no y-intercept;

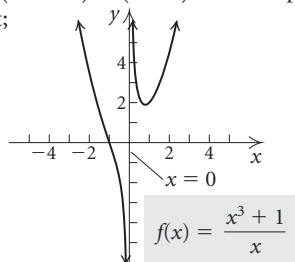

73. Domain: $(-\infty, -2) \cup (-2, 7) \cup (7, \infty)$;
 x-intercepts: $(-5, 0)$, $(0, 0)$, and $(3, 0)$, y-intercept: $(0, 0)$;

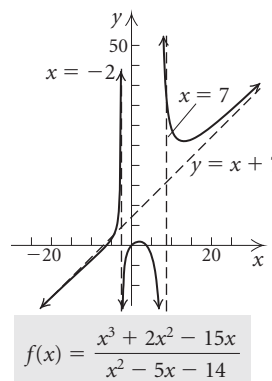

75. Domain: $(-\infty, \infty)$; x-intercept: $(0, 0)$, y-intercept: $(0, 0)$;

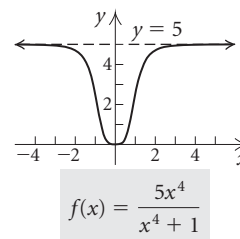

77. Domain: $(-\infty, -1) \cup (-1, 2) \cup (2, \infty)$;
 x-intercept: $(0, 0)$, y-intercept: $(0, 0)$;

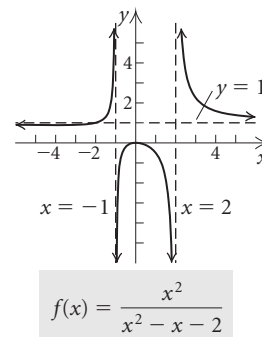

79. $f(x) = \frac{1}{x^2 - x - 20}$ 81. $f(x) = \frac{3x^2 + 12x + 12}{2x^2 - 2x - 40}$

83. (a) $N(t) \rightarrow 0.16$ as $t \rightarrow \infty$; (b) The medication never completely disappears from the body; a trace amount remains.

85. (a) $P(0) = 0$; $P(1) = 45,455$; $P(3) = 55,556$;
 $P(8) = 29,197$; (b) $P(t) \rightarrow 0$ as $t \rightarrow \infty$; (c) In time, no one lives in this community. 86. [1.2] Domain, range, domain, range 87. [1.3] Slope 88. [1.3] Slope–intercept equation
 89. [1.4] Point–slope equation 90. [1.1] x-intercept
 91. [2.4] $f(-x) = -f(x)$ 92. [1.3] Vertical lines
 93. [1.1] Midpoint formula 94. [1.1] y-intercept
 95. $y = x^3 + 4$

97.

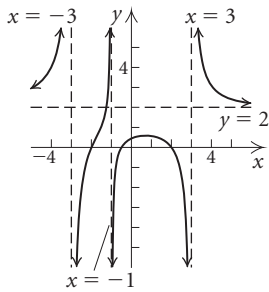

$$f(x) = \frac{2x^3 + x^2 - 8x - 4}{x^3 + x^2 - 9x - 9}$$

Exercise Set 4.6

1. $\{-5, 3\}$ 3. $[-5, 3]$ 5. $(-\infty, -5] \cup [3, \infty)$
 7. $(-\infty, -4) \cup (2, \infty)$ 9. $(-\infty, -4) \cup [2, \infty)$
 11. $\{0\}$ 13. $(-5, 0] \cup (1, \infty)$ 15. $(-\infty, -5) \cup (0, 1)$
 17. $(-\infty, -3) \cup (0, 3)$ 19. $(-3, 0) \cup (3, \infty)$
 21. $(-\infty, -5) \cup (-3, 2)$ 23. $(-2, 0] \cup (2, \infty)$
 25. $(-4, 1)$ 27. $(-\infty, -2) \cup (1, \infty)$
 29. $(-\infty, -1] \cup [3, \infty)$ 31. $(-\infty, -5) \cup (5, \infty)$
 33. $(-\infty, -2] \cup [2, \infty)$ 35. $(-\infty, 3) \cup (3, \infty)$
 37. \emptyset 39. $(-\infty, -\frac{5}{4}] \cup [0, 3]$ 41. $[-3, -1] \cup [1, \infty)$
 43. $(-\infty, -2) \cup (1, 3)$ 45. $[-\sqrt{2}, -1] \cup [\sqrt{2}, \infty)$
 47. $(-\infty, -1] \cup [\frac{3}{2}, 2]$ 49. $(-\infty, 5]$
 51. $(-\infty, -1.680) \cup (2.154, 5.526)$ 53. $-4; (-4, \infty)$
 55. $-\frac{5}{2}; (-\frac{5}{2}, \infty)$ 57. $0, 4; (-\infty, 0] \cup (4, \infty)$
 59. $-3, -\frac{1}{5}, 1; (-3, -\frac{1}{5}] \cup (1, \infty)$ 61. $2, \frac{46}{11}, 5;$
 $(2, \frac{46}{11}) \cup (5, \infty)$ 63. $2, \frac{7}{2}; [2, \frac{7}{2}]$ 65. $1 - \sqrt{2},$
 $0, 1 + \sqrt{2}; (1 - \sqrt{2}, 0) \cup (1 + \sqrt{2}, \infty)$
 67. $-3, 1, 3, \frac{11}{3}; (-\infty, -3) \cup (1, 3) \cup [\frac{11}{3}, \infty)$
 69. $0; (-\infty, \infty)$ 71. $-3, \frac{1 - \sqrt{61}}{6}, -\frac{1}{2}, 0, \frac{1 + \sqrt{61}}{6};$
 $(-3, \frac{1 - \sqrt{61}}{6}) \cup (-\frac{1}{2}, 0) \cup (\frac{1 + \sqrt{61}}{6}, \infty)$
 73. $-1, 0, \frac{2}{7}, \frac{7}{2}; (-1, 0) \cup (\frac{2}{7}, \frac{7}{2})$ 75. $-6 - \sqrt{33}, -5,$
 $-6 + \sqrt{33}, 1, 5; [-6 - \sqrt{33}, -5] \cup [-6 + \sqrt{33}, 1] \cup (5, \infty)$
 77. $(0.408, 2.449)$ 79. (a) $(10, 200)$; (b) $(0, 10) \cup (200, \infty)$
 81. $\{n \mid 9 \leq n \leq 23\}$ 83. $[1.1] (x + 2)^2 + (y - 4)^2 = 9$
 84. $[1.1] x^2 + (y + 3)^2 = \frac{49}{16}$ 85. $[3.3]$ (a) $(\frac{3}{4}, -\frac{55}{8});$
 (b) maximum: $-\frac{55}{8}$ when $x = \frac{3}{4}$; (c) $(-\infty, -\frac{55}{8}]$
 86. $[3.3]$ (a) $(5, -23)$; (b) minimum: -23 when $x = 5$;
 (c) $[-23, \infty)$ 87. $[-\sqrt{5}, \sqrt{5}]$ 89. $[-\frac{3}{2}, \frac{3}{2}]$
 91. $(-\infty, -\frac{1}{4}) \cup (\frac{1}{2}, \infty)$ 93. $x^2 + x - 12 < 0$; answers
 may vary 95. $(-\infty, -3) \cup (7, \infty)$

Review Exercises: Chapter 4

1. True 2. True 3. False 4. False 5. False
 6. $0.45x^4, 0.45, 4$, quartic 7. $-25, -25, 0$, constant

8. $-0.5x, -0.5, 1$, linear 9. $\frac{1}{3}x^3, \frac{1}{3}, 3$, cubic 10. As $x \rightarrow \infty$, $f(x) \rightarrow -\infty$, and as $x \rightarrow -\infty$, $f(x) \rightarrow -\infty$.

11. As $x \rightarrow \infty$, $f(x) \rightarrow \infty$, and as $x \rightarrow -\infty$, $f(x) \rightarrow -\infty$.

12. $\frac{2}{3}$, multiplicity 1; -2 , multiplicity 3; 5 , multiplicity 2

13. $\pm 1, \pm 5$, each has multiplicity 1 14. $\pm 3, -4$, each has multiplicity 1 15. (a) 4%; (b) 5%

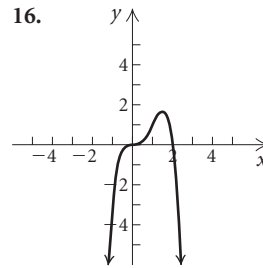

$$f(x) = -x^4 + 2x^3$$

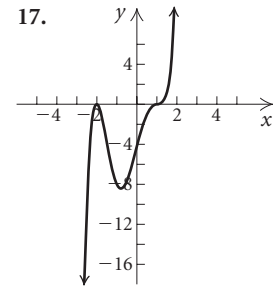

$$g(x) = (x - 1)^3(x + 2)^2$$

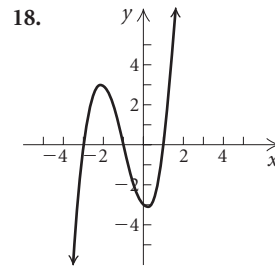

$$h(x) = x^3 + 3x^2 - x - 3$$

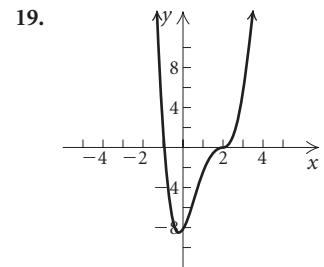

$$f(x) = x^4 - 5x^3 + 6x^2 + 4x - 8$$

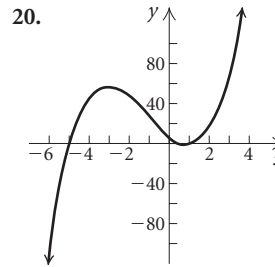

$$g(x) = 2x^3 + 7x^2 - 14x + 5$$

20. 21. $f(1) = -4$ and $f(2) = 3$. Since $f(1)$ and $f(2)$ have opposite signs, $f(x)$ has a zero between 1 and 2.
 22. $f(-1) = -3.5$ and $f(1) = -0.5$. Since $f(-1)$ and $f(1)$ have the same sign, the intermediate value theorem does not allow us to determine whether there is a zero between -1 and 1 .
 23. $Q(x) = 6x^2 + 16x + 52, R(x) = 155;$
 $P(x) = (x - 3)(6x^2 + 16x + 52) + 155$
 24. $Q(x) = x^3 - 3x^2 + 3x - 2, R(x) = 7;$
 $P(x) = (x + 1)(x^3 - 3x^2 + 3x - 2) + 7$
 25. $x^2 + 7x + 22, R 120$ 26. $x^3 + x^2 + x + 1, R 0$
 27. $x^4 - x^3 + x^2 - x - 1, R 1$ 28. 36 29. 0
 30. $-141, 220$ 31. Yes, no 32. No, yes 33. Yes, no
 34. No, yes 35. $f(x) = (x - 1)^2(x + 4); -4, 1$
 36. $f(x) = (x - 2)(x + 3)^2; -3, 2$
 37. $f(x) = (x - 2)^2(x - 5)(x + 5); -5, 2, 5$
 38. $f(x) = (x - 1)(x + 1)(x - \sqrt{2})(x + \sqrt{2});$
 $-\sqrt{2}, -1, 1, \sqrt{2}$ 39. $f(x) = x^3 + 3x^2 - 6x - 8$
 40. $f(x) = x^3 + x^2 - 4x + 6$
 41. $f(x) = x^3 - \frac{5}{2}x^2 + \frac{1}{2}$, or $2x^3 - 5x^2 + 1$

42. $f(x) = x^4 + \frac{29}{2}x^3 + \frac{135}{2}x^2 + \frac{175}{2}x - \frac{125}{2}$, or $2x^4 + 29x^3 + 135x^2 + 175x - 125$

43. $f(x) = x^5 + 4x^4 - 3x^3 - 18x^2$

44. $-\sqrt{5}, -i$ 45. $1 - \sqrt{3}, \sqrt{3}$ 46. $\sqrt{2}$

47. $f(x) = x^2 - 11$ 48. $f(x) = x^3 - 6x^2 + x - 6$

49. $f(x) = x^4 - 5x^3 + 4x^2 + 2x - 8$

50. $f(x) = x^4 - x^2 - 20$ 51. $f(x) = x^3 + \frac{8}{3}x^2 - x$

52. $\pm\frac{1}{4}, \pm\frac{1}{2}, \pm\frac{3}{4}, \pm 1, \pm\frac{3}{2}, \pm 2, \pm 3, \pm 4, \pm 6, \pm 12$

53. $\pm\frac{1}{3}, \pm 1$ 54. $\pm 1, \pm 2, \pm 3, \pm 4, \pm 6, \pm 8, \pm 12, \pm 24$

55. (a) Rational: $0, -2, \frac{1}{3}, 3$; other: none;

(b) $f(x) = 3x(x - \frac{1}{3})(x + 2)^2(x - 3)$ 56. (a) Rational: 2; other: $\pm\sqrt{3}$; (b) $f(x) = (x - 2)(x + \sqrt{3})(x - \sqrt{3})$

57. (a) Rational: $-1, 1$; other: $3 \pm i$;

(b) $f(x) = (x + 1)(x - 1)(x - 3 - i)(x - 3 + i)$

58. (a) Rational: -5 ; other: $1 \pm \sqrt{2}$;

(b) $f(x) = (x + 5)(x - 1 - \sqrt{2})(x - 1 + \sqrt{2})$

59. (a) Rational: $\frac{2}{3}, 1$; other: none;

(b) $f(x) = 3(x - \frac{2}{3})(x - 1)^2$

60. (a) Rational: 2; other: $1 \pm \sqrt{5}$;

(b) $f(x) = (x - 2)^3(x - 1 + \sqrt{5})(x - 1 - \sqrt{5})$

61. (a) Rational: $-4, 0, 3, 4$; other: none;

(b) $f(x) = x^2(x + 4)^2(x - 3)(x - 4)$

62. (a) Rational: $\frac{5}{2}, 1$; other: none;

(b) $f(x) = 2(x - \frac{5}{2})(x - 1)^4$, or $(2x - 5)(x - 1)^4$

63. 3 or 1; 0 64. 4 or 2 or 0; 2 or 0 65. 3 or 1; 0

66. Domain: $(-\infty, -2) \cup (-2, \infty)$; x-intercepts: $(-\sqrt{5}, 0)$ and $(\sqrt{5}, 0)$; y-intercept: $(0, -\frac{5}{2})$

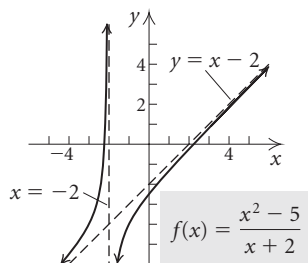

67. Domain: $(-\infty, 2) \cup (2, \infty)$; x-intercepts: none; y-intercept: $(0, \frac{5}{4})$

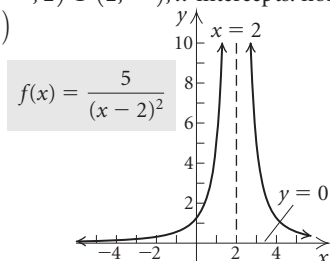

68. Domain: $(-\infty, -4) \cup (-4, 5) \cup (5, \infty)$; x-intercepts: $(-3, 0)$ and $(2, 0)$; y-intercept: $(0, \frac{3}{10})$

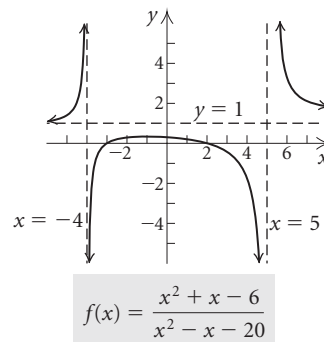

69. Domain: $(-\infty, -3) \cup (-3, 5) \cup (5, \infty)$; x-intercept: $(2, 0)$; y-intercept: $(0, \frac{2}{15})$

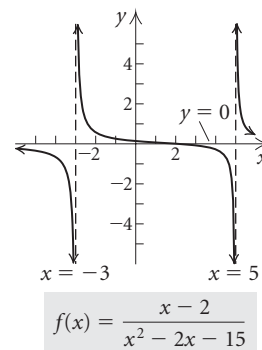

70. $f(x) = \frac{1}{x^2 - x - 6}$ 71. $f(x) = \frac{4x^2 + 12x}{x^2 - x - 6}$

 72. (a) $N(t) \rightarrow 0.0875$ as $t \rightarrow \infty$; (b) The medication never completely disappears from the body; a trace amount remains.

73. $(-3, 3)$ 74. $(-\infty, -\frac{1}{2}) \cup (2, \infty)$

75. $[-4, 1] \cup [2, \infty)$ 76. $(-\infty, -\frac{14}{3}) \cup (-3, \infty)$

77. (a) $t = 7$; (b) $(2, 3)$ 78. $\left[\frac{5 - \sqrt{15}}{2}, \frac{5 + \sqrt{15}}{2}\right]$

79. A 80. C 81. B

82. $(-\infty, -1 - \sqrt{6}) \cup [-1 + \sqrt{6}, \infty)$

83. $(-\infty, -\frac{1}{2}) \cup (\frac{1}{2}, \infty)$ 84. $\{1 + i, 1 - i, i, -i\}$

85. $(-\infty, 2)$ 86. $(x - 1)\left(x + \frac{1}{2} - \frac{\sqrt{3}}{2}i\right)\left(x + \frac{1}{2} + \frac{\sqrt{3}}{2}i\right)$

87. 7 88. -4 89. $(-\infty, -5] \cup [2, \infty)$

90. $(-\infty, 1.1] \cup [2, \infty)$ 91. $(-1, \frac{3}{7})$

92. A polynomial function is a function that can be defined by a polynomial expression. A rational function is a function that can be defined as a quotient of two polynomials. 93. No; since imaginary zeros of polynomials with rational coefficients occur in conjugate pairs, a third-degree polynomial with rational coefficients can have at most two imaginary zeros. Thus there must be at least one real zero.

94. Vertical asymptotes occur at any x -values that make the denominator zero. The graph of a rational function does not cross any vertical asymptotes. Horizontal asymptotes occur when the degree of the numerator is less than or equal to the degree of the denominator. Oblique asymptotes occur when the degree of the numerator is 1 greater than the degree of the denominator. Graphs of rational functions may cross horizontal or oblique asymptotes. 95. If $P(x)$ is an even function, then $P(-x) = P(x)$ and thus $P(-x)$ has the same number of sign changes as $P(x)$. Hence, $P(x)$ has one negative real zero also. 96. A horizontal asymptote occurs when the degree of the numerator of a rational function is less than or equal to the degree of the denominator. An oblique asymptote occurs when the degree of the numerator is 1 greater than the degree of the denominator. Thus a rational function cannot have both a horizontal asymptote and an oblique asymptote. 97. A quadratic inequality $ax^2 + bx + c \leq 0$, $a > 0$, or $ax^2 + bx + c \geq 0$, $a < 0$, has a solution set that is a closed interval.

Test: Chapter 4

1. [4.1] $-x^4$, -1 , 4 ; quartic 2. [4.1] $-4.7x$, -4.7 , 1 ; linear
 3. [4.1] $0, \frac{5}{3}$, each has multiplicity 1; 3 , multiplicity 2; -1 , multiplicity 3 4. [4.1] 1930: 11.3%; 1990: 7.9%; 2000: 10.5%
 5. [4.2]

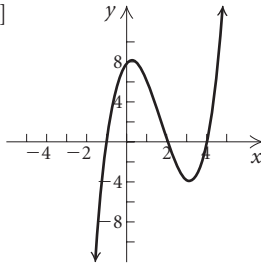

$$f(x) = x^3 - 5x^2 + 2x + 8$$

6. [4.2]

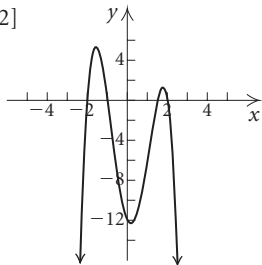

$$f(x) = -2x^4 + x^3 + 11x^2 - 4x - 12$$

7. [4.2] $f(0) = 3$ and $f(2) = -17$. Since $f(0)$ and $f(2)$ have opposite signs, $f(x)$ has a zero between 0 and 2.
 8. [4.2] $g(-2) = 5$ and $g(-1) = 1$. Both $g(-2)$ and $g(-1)$ are positive. We cannot use the intermediate value theorem to determine if there is a zero between -2 and -1 .
 9. [4.3] $Q(x) = x^3 + 4x^2 + 4x + 6$, $R(x) = 1$;
 $P(x) = (x - 1)(x^3 + 4x^2 + 4x + 6) + 1$
 10. [4.3] $3x^2 + 15x + 63$, R 322 11. [4.3] -115

12. [4.3] Yes 13. [4.4] $f(x) = x^4 - 27x^2 - 54x$
 14. [4.4] $-\sqrt{3}, 2 + i$
 15. [4.4] $f(x) = x^3 + 10x^2 + 9x + 90$
 16. [4.4] $f(x) = x^5 - 2x^4 - x^3 + 6x^2 - 6x$
 17. [4.4] $\pm 1, \pm 2, \pm 3, \pm 4, \pm 6, \pm 12, \pm \frac{1}{2}, \pm \frac{3}{2}$
 18. [4.4] $\pm \frac{1}{10}, \pm \frac{1}{5}, \pm \frac{1}{2}, \pm 1, \pm \frac{5}{2}, \pm 5$
 19. [4.4] (a) Rational: -1 ; other: $\pm \sqrt{5}$;
 (b) $f(x) = (x + 1)(x - \sqrt{5})(x + \sqrt{5})$
 20. [4.4] (a) Rational: $-\frac{1}{2}, 1, 2, 3$; other: none;
 (b) $f(x) = 2(x + \frac{1}{2})(x - 1)(x - 2)(x - 3)$
 21. [4.4] (a) Rational: -4 ; other: $\pm 2i$;
 (b) $f(x) = (x - 2i)(x + 2i)(x + 4)$
 22. [4.4] (a) Rational: $\frac{2}{3}, 1$; other: none;
 (b) $f(x) = 3(x - \frac{2}{3})(x - 1)^3$ 23. [4.4] 2 or 0; 2 or 0
 24. [4.5] Domain: $(-\infty, 3) \cup (3, \infty)$; x -intercepts: none,
 y -intercept: $(0, \frac{2}{9})$;

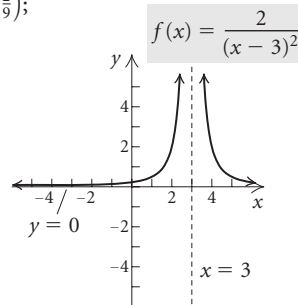

25. [4.5] Domain: $(-\infty, -1) \cup (-1, 4) \cup (4, \infty)$;
 x -intercept: $(-3, 0)$, y -intercept: $(0, -\frac{3}{4})$;

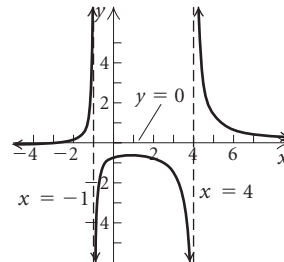

$$f(x) = \frac{x + 3}{x^2 - 3x - 4}$$

26. [4.5] Answers may vary; $f(x) = \frac{x + 4}{x^2 - x - 2}$
 27. [4.6] $(-\infty, -\frac{1}{2}) \cup (3, \infty)$ 28. [4.6] $(-\infty, 4) \cup [\frac{13}{2}, \infty)$
 29. (a) [4.1] 6 sec; (b) [4.1], [4.6] $(1, 3)$ 30. [4.2] D
 31. [4.1], [4.6] $(-\infty, -4] \cup [3, \infty)$

Chapter 5

Exercise Set 5.1

1. $\{(8, 7), (8, -2), (-4, 3), (-8, 8)\}$
 3. $\{(-1, -1), (4, -3)\}$ 5. $x = 4y - 5$
 7. $y^3x = -5$ 9. $y = x^2 - 2x$

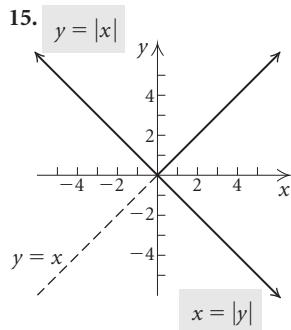
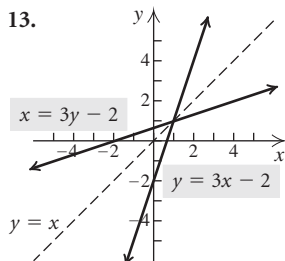
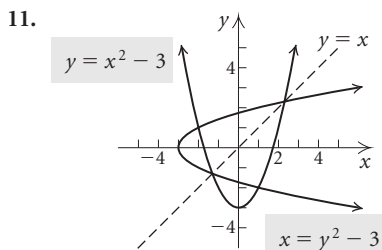

17. Assume $f(a) = f(b)$ for any numbers a and b in the domain of f . Since $f(a) = \frac{1}{3}a - 6$ and $f(b) = \frac{1}{3}b - 6$, we have

$$\frac{1}{3}a - 6 = \frac{1}{3}b - 6$$

$$\frac{1}{3}a = \frac{1}{3}b \quad \text{Adding 6}$$

$$a = b. \quad \text{Multiplying by 3}$$

Thus, if $f(a) = f(b)$, then $a = b$ and f is one-to-one.

19. Assume $f(a) = f(b)$ for any numbers a and b in the domain of f . Since $f(a) = a^3 + \frac{1}{2}$ and $f(b) = b^3 + \frac{1}{2}$, we have

$$a^3 + \frac{1}{2} = b^3 + \frac{1}{2}$$

$$a^3 = b^3 \quad \text{Subtracting } \frac{1}{2}$$

$$a = b. \quad \text{Taking the cube root}$$

Thus, if $f(a) = f(b)$, then $a = b$ and f is one-to-one.

21. Find two numbers a and b for which $a \neq b$ and $g(a) = g(b)$. Two such numbers are -2 and 2 , because $g(-2) = g(2) = -3$. Thus, g is not one-to-one.

23. Find two numbers a and b for which $a \neq b$ and $g(a) = g(b)$. Two such numbers are -1 and 1 , because $g(-1) = g(1) = 0$. Thus, g is not one-to-one.

25. Yes 27. No 29. No 31. Yes 33. Yes

35. No 37. No 39. Yes 41. No 43. No

45. (a) One-to-one; (b) $f^{-1}(x) = x - 4$

47. (a) One-to-one; (b) $f^{-1}(x) = \frac{x+1}{2}$

49. (a) One-to-one; (b) $f^{-1}(x) = \frac{4}{x} - 7$

51. (a) One-to-one; (b) $f^{-1}(x) = \frac{3x+4}{x-1}$

53. (a) One-to-one; (b) $f^{-1}(x) = \sqrt[3]{x+1}$

55. (a) Not one-to-one; (b) does not have an inverse that is a function 57. (a) One-to-one; (b) $f^{-1}(x) = \sqrt{\frac{x+2}{5}}$

59. (a) One-to-one; (b) $f^{-1}(x) = x^2 - 1, x \geq 0$ 61. $\frac{1}{3}x$

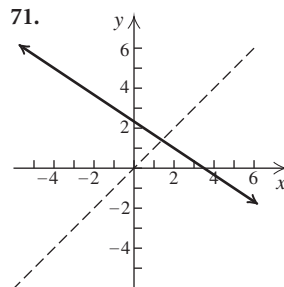
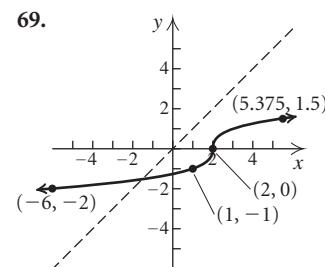
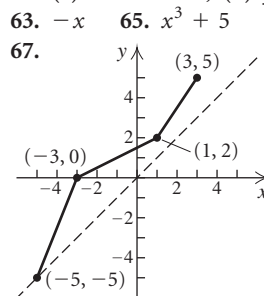

73. $f^{-1}(f(x)) = f^{-1}\left(\frac{7}{8}x\right) = \frac{8}{7} \cdot \frac{7}{8}x = x$;
 $f(f^{-1}(x)) = f\left(\frac{8}{7}x\right) = \frac{7}{8} \cdot \frac{8}{7}x = x$

75. $f^{-1}(f(x)) = f^{-1}\left(\frac{1-x}{x}\right) = \frac{1}{\frac{1-x}{x} + 1} =$

$$\frac{1}{\frac{1-x}{x} + 1} = \frac{1}{\frac{1-x}{x} + \frac{x}{x}} = \frac{1}{\frac{1-x+x}{x}} = \frac{1}{\frac{1}{x}} = 1 \cdot \frac{x}{1} = x; f(f^{-1}(x)) = f\left(\frac{1}{x+1}\right) =$$

$$\frac{1 - \frac{1}{x+1}}{\frac{1}{x+1} + 1} = \frac{\frac{x+1-1}{x+1}}{\frac{1}{x+1} + \frac{x+1}{x+1}} = \frac{\frac{x}{x+1}}{\frac{1+x+1}{x+1}} = \frac{x}{x+1} \cdot \frac{x+1}{1} = x$$

77. $f^{-1}(f(x)) = f^{-1}\left(\frac{2}{5}x + 1\right) = \frac{5\left(\frac{2}{5}x + 1\right) - 5}{2} =$

$$\frac{2x + 5 - 5}{2} = \frac{2x}{2} = x; f(f^{-1}(x)) = f\left(\frac{5x-5}{2}\right) =$$

$$\frac{2}{5}\left(\frac{5x-5}{2}\right) + 1 = x - 1 + 1 = x$$

79. $f^{-1}(x) = \frac{1}{5}x + \frac{3}{5}$; domain of f and f^{-1} : $(-\infty, \infty)$; range of f and f^{-1} : $(-\infty, \infty)$;

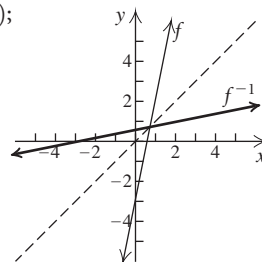

81. $f^{-1}(x) = \frac{2}{x}$; domain of f and f^{-1} : $(-\infty, 0) \cup (0, \infty)$;
range of f and f^{-1} : $(-\infty, 0) \cup (0, \infty)$;

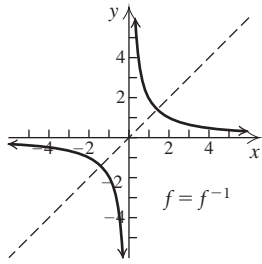

83. $f^{-1}(x) = \sqrt[3]{3x + 6}$; domain of f and f^{-1} : $(-\infty, \infty)$;
range of f and f^{-1} : $(-\infty, \infty)$;

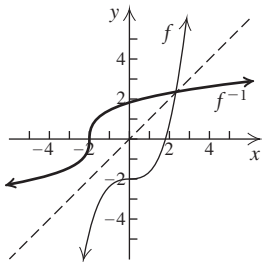

85. $f^{-1}(x) = \frac{3x + 1}{x - 1}$; domain of f : $(-\infty, 3) \cup (3, \infty)$;
range of f : $(-\infty, 1) \cup (1, \infty)$;
domain of f^{-1} : $(-\infty, 1) \cup (1, \infty)$;
range of f^{-1} : $(-\infty, 3) \cup (3, \infty)$;

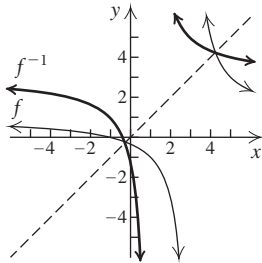

87. 5; a 89. (a) $3\frac{1}{2}$, 6, $6\frac{1}{2}$; (b) $s^{-1}(x) = \frac{2x + 3}{2}$;
(c) $4\frac{1}{2}$, 7, $8\frac{1}{2}$ 91. (a) 2005: about \$36.2 billion, 2010: about \$47.1 billion; (b) $P^{-1}(x) = \frac{x - 25.3}{2.1782}$; $P^{-1}(x)$ represents the number of years after 2000, when x billions of dollars are spent on pets per year. 93. [3.3] (b), (d), (f), (h) 94. [3.3] (a), (c), (e), (g) 95. [3.3] (a) 96. [3.3] (d) 97. [3.3] (f) 98. [3.3] (a), (b), (c), (d) 99. $f(x) = x^2 - 3$, for inputs $x \geq 0$; $f^{-1}(x) = \sqrt{x + 3}$, for inputs $x \geq -3$
101. Answers may vary; $f(x) = 3/x$, $f(x) = 1 - x$, $f(x) = x$

Exercise Set 5.2

1. 54.5982 3. 0.0856 5. (f) 7. (e) 9. (a)

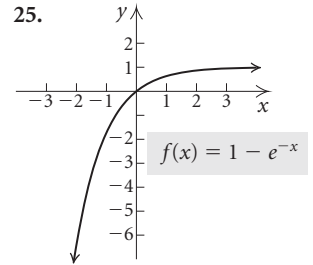
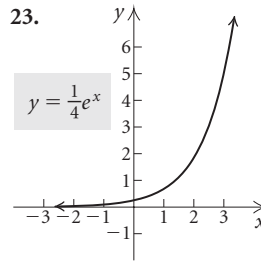
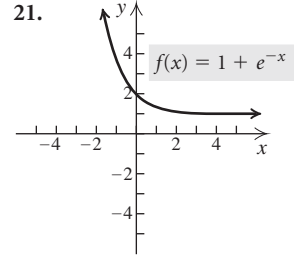
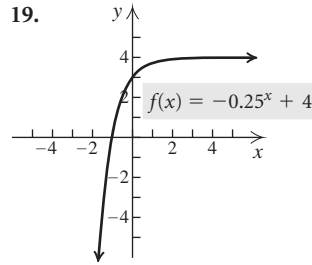
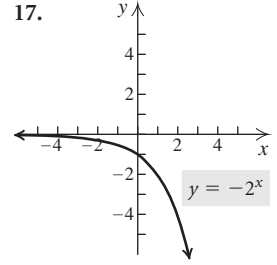
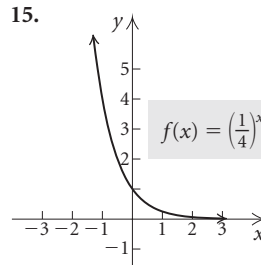
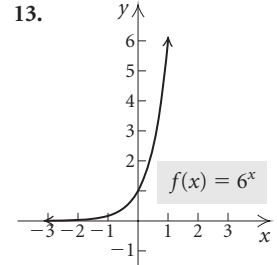
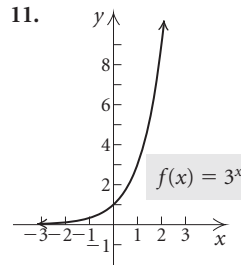

27. Shift the graph of $y = 2^x$ left 1 unit.

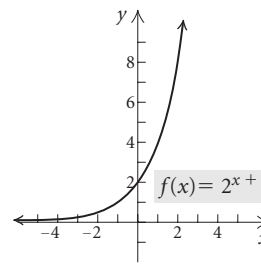

29. Shift the graph of $y = 2^x$ down 3 units.

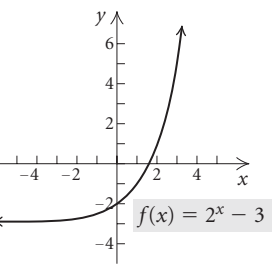

31. Shift the graph of $y = 2^x$ left 1 unit, reflect it across the y -axis, and shift it up 2 units.

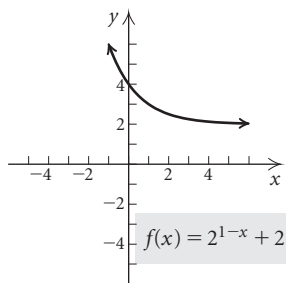

33. Reflect the graph of $y = 3^x$ across the y -axis and then across the x -axis and then shift it up 4 units.

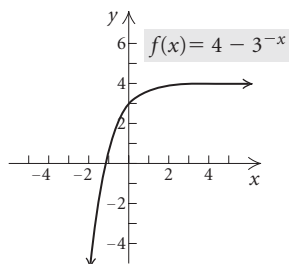

35. Shift the graph of $y = (\frac{3}{2})^x$ right 1 unit.

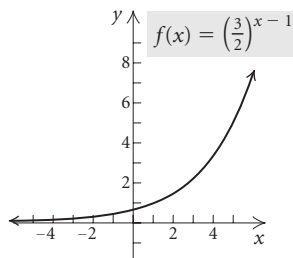

37. Shift the graph of $y = 2^x$ left 3 units and then down 5 units.

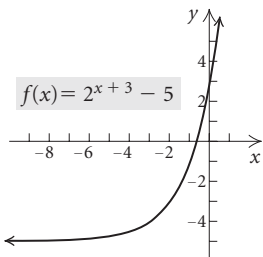

39. Shift the graph of $y = 2^x$ right 1 unit, stretch it vertically, and shift it up 1 unit.

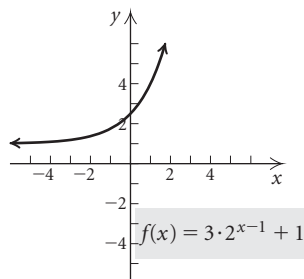

41. Shrink the graph of $y = e^x$ horizontally.

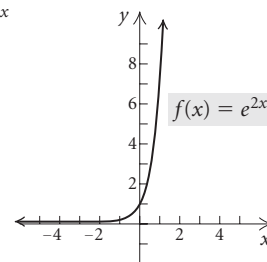

43. Reflect the graph of $y = e^x$ across the x -axis, shift it up 1 unit, and shrink it vertically.

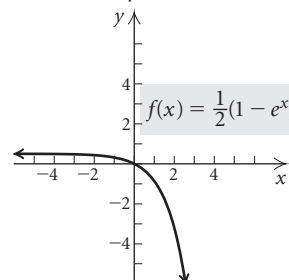

45. Shift the graph of $y = e^x$ left 1 unit and then reflect it across the y -axis.

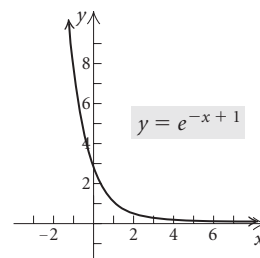

47. Reflect the graph of $y = e^x$ across the y -axis, then across the x -axis, then shift it up 1 unit, and then stretch it vertically.

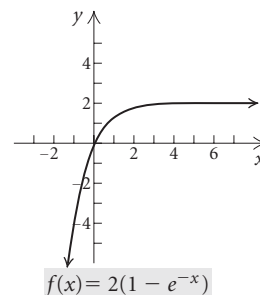

- 49.

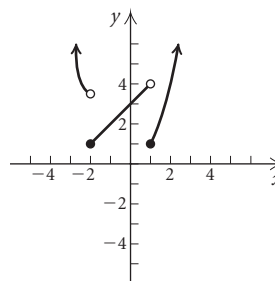

$$f(x) = \begin{cases} e^{-x} - 4, & \text{for } x < -2, \\ x + 3, & \text{for } -2 \leq x < 1, \\ x^2, & \text{for } x \geq 1 \end{cases}$$

51. (a) $A(t) = 82,000(1.01125)^{4t}$; (b) \$82,000; \$89,677.22; \$102,561.54; \$128,278.90
 53. \$4930.86 55. \$3247.30
 57. \$153,610.15 59. \$76,305.59 61. \$26,086.69
 63. 2000: 29,272 servicemembers; 2008: 68,436 servicemembers; 2011: 94,102 servicemembers 65. 1950: 2900 pages; 1990: 24,689 pages; 2000: 42,172 pages 67. 2003: \$278,574; 2007: \$540,460; 2013: \$1,460,486 69. 1999: 122,370 tons; 2007: 380,099 tons; 2012: 771,855 tons 71. 2007: about 25.5 million; 2014: about 42.4 million 73. \$56,395; \$50,756; \$41,112; \$29,971; \$19,664 75. About 63%
 77. [3.1] $31 - 22i$ 78. [3.1] $\frac{1}{2} - \frac{1}{2}i$ 79. [3.2] $(-\frac{1}{2}, 0)$, $(7, 0)$; $-\frac{1}{2}, 7$ 80. [4.4] $(1, 0)$; 1 81. [4.1] $(-1, 0)$, $(0, 0)$, $(1, 0)$; $-1, 0, 1$ 82. [4.1] $(-4, 0)$, $(0, 0)$, $(3, 0)$; $-4, 0, 3$
 83. [4.1] $-8, 0, 2$ 84. [3.2] $\frac{5 \pm \sqrt{97}}{6}$ 85. π^7 ; 70^{80}

Visualizing the Graph

1. J 2. F 3. H 4. B 5. E 6. A 7. C
 8. I 9. D 10. G

Exercise Set 5.3

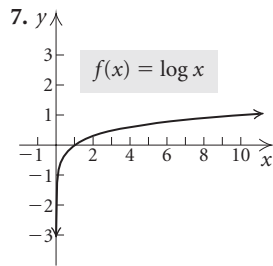
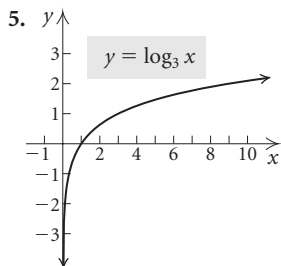
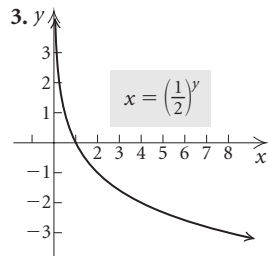
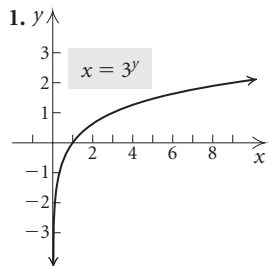

9. 4 11. 3 13. -3 15. -2 17. 0 19. 1
 21. 4 23. $\frac{1}{4}$ 25. -7 27. $\frac{1}{2}$ 29. $\frac{3}{4}$ 31. 0 33. $\frac{1}{2}$
 35. $\log_{10} 1000 = 3$, or $\log 1000 = 3$ 37. $\log_8 2 = \frac{1}{3}$
 39. $\log_e t = 3$, or $\ln t = 3$ 41. $\log_e 7.3891 = 2$, or $\ln 7.3891 = 2$ 43. $\log_p 3 = k$ 45. $5^1 = 5$
 47. $10^{-2} = 0.01$ 49. $e^{3.4012} = 30$ 51. $a^{-x} = M$
 53. $a^x = T^3$ 55. 0.4771 57. 2.7259 59. -0.2441
 61. Does not exist 63. 0.6931 65. 6.6962 67. Does not exist
 69. 3.3219 71. -0.2614 73. 0.7384
 75. 2.2619 77. 0.5880

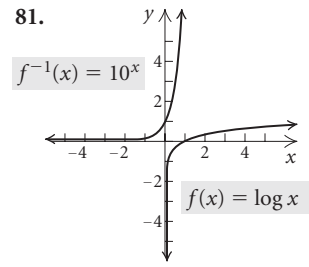
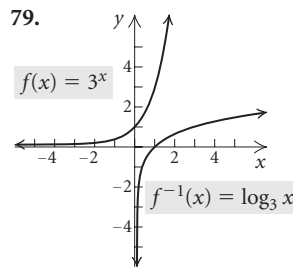

83. Shift the graph of $y = \log_2 x$ left 3 units. Domain: $(-3, \infty)$; vertical asymptote: $x = -3$;

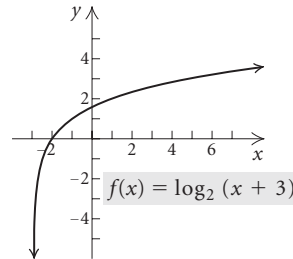

85. Shift the graph of $y = \log_3 x$ down 1 unit. Domain: $(0, \infty)$; vertical asymptote: $x = 0$;

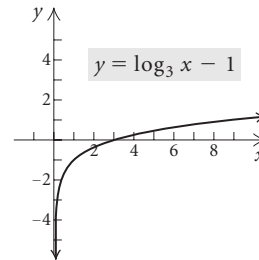

87. Stretch the graph of $y = \ln x$ vertically. Domain: $(0, \infty)$; vertical asymptote: $x = 0$;

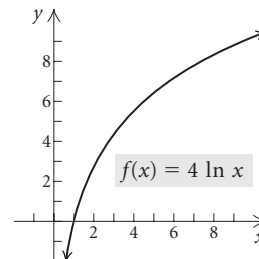

89. Reflect the graph of $y = \ln x$ across the x -axis and shift it up 2 units. Domain: $(0, \infty)$; vertical asymptote: $x = 0$;

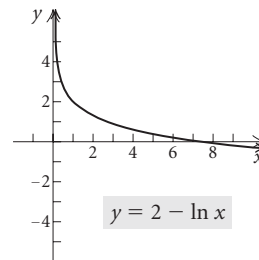

91. Shift the graph of $\log x$ right 1 unit, shrink it vertically, and shift it down 2 units.

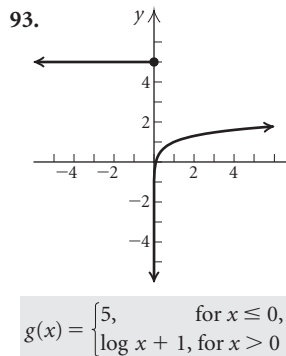
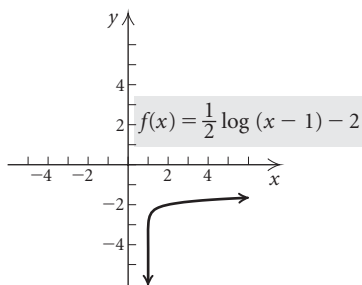

95. (a) 2.4 ft/sec;
 (b) 3.1 ft/sec; (c) 2.3 ft/sec;
 (d) 2.9 ft/sec; (e) 2.5 ft/sec;
 (f) 2.2 ft/sec; (g) 2.5 ft/sec;
 (h) 2.1 ft/sec 97. (a) 7.7;
 (b) 9.5; (c) 6.6; (d) 7.4;
 (e) 8.0; (f) 7.9; (g) 9.1;
 (h) 6.9 99. (a) 10^{-7} ;
 (b) 4.0×10^{-6} ;
 (c) 6.3×10^{-4} ;
 (d) 1.6×10^{-5}

101. (a) 140 decibels; (b) 115 decibels; (c) 90 decibels;
 (d) 65 decibels; (e) 100 decibels; (f) 194 decibels
 102. [1.4] $m = \frac{3}{10}$; y-intercept: $(0, -\frac{7}{5})$ 103. [1.4] $m = 0$;
 y-intercept: $(0, 6)$ 104. [1.4] Slope is not defined; no
 y-intercept 105. [4.3] -280 106. [4.3] -4 107. [4.4]
 $f(x) = x^3 - 7x$ 108. [4.4] $f(x) = x^3 - x^2 + 16x - 16$
 109. 3 111. $(0, \infty)$ 113. $(-\infty, 0) \cup (0, \infty)$
 115. $(-\frac{5}{2}, -2)$ 117. (d) 119. (b)

Mid-Chapter Mixed Review: Chapter 5

1. False 2. True 3. False 4. Yes; $f^{-1}(x) = -\frac{2}{x}$
 5. No 6. Yes; $f^{-1}(x) = \frac{5}{x} + 2$
 7. $(f^{-1} \circ f)(x) = f^{-1}(\sqrt{x-5}) = (\sqrt{x-5})^2 + 5 = x - 5 + 5 = x$;
 $(f \circ f^{-1})(x) = f(x^2 + 5) = \sqrt{(x^2 + 5) - 5} = \sqrt{x^2} = x$ 8. $f^{-1}(x) = \sqrt[3]{x-2}$;
 domain of f : $(-\infty, \infty)$, range of f : $(-\infty, \infty)$; domain of
 f^{-1} : $(-\infty, \infty)$, range of f^{-1} : $(-\infty, \infty)$ 9. (d) 10. (h)
 11. (c) 12. (g) 13. (b) 14. (f) 15. (e) 16. (a)
 17. \$4185.57 18. 0 19. $-\frac{4}{5}$ 20. -2 21. 2 22. 0
 23. -4 24. 0 25. 3 26. $\frac{1}{4}$ 27. 1 28. $\ln 0.0025 = -6$
 29. $10^T = T$ 30. 2.7268 31. 2.0115 32. For an even
 function f , $f(x) = f(-x)$, so we have $f(x) = f(-x)$ but
 $x \neq -x$ (for $x \neq 0$). Thus, f is not one-to-one and hence it
 does not have an inverse. 33. The most interest will be
 earned the eighth year, because the principal is greatest during
 that year. 34. In $f(x) = x^3$, the variable x is the base. The
 range of f is $(-\infty, \infty)$. In $g(x) = 3^x$, the variable x is the expo-
 nent. The range of g is $(0, \infty)$. The graph of f does not have an
 asymptote. The graph of g has an asymptote $y = 0$.
 35. If $\log b < 0$, then $0 < b < 1$.

Exercise Set 5.4

1. $\log_3 81 + \log_3 27 = 4 + 3 = 7$
 3. $\log_5 5 + \log_5 125 = 1 + 3 = 4$ 5. $\log_t 8 + \log_t Y$
 7. $\ln x + \ln y$ 9. $3 \log_b t$ 11. $8 \log y$ 13. $-6 \log_c K$
 15. $\frac{1}{3} \ln 4$ 17. $\log_t M - \log_t 8$ 19. $\log x - \log y$
 21. $\ln r - \ln s$ 23. $\log_a 6 + \log_a x + 5 \log_a y + 4 \log_a z$
 25. $2 \log_b p + 5 \log_b q - 4 \log_b m - 9$
 27. $\ln 2 - \ln 3 - 3 \ln x - \ln y$ 29. $\frac{3}{2} \log r + \frac{1}{2} \log t$
 31. $3 \log_a x - \frac{5}{2} \log_a p - 4 \log_a q$
 33. $2 \log_a m + 3 \log_a n - \frac{3}{4} - \frac{5}{4} \log_a b$
 35. $\log_a 150$ 37. $\log 100 = 2$ 39. $\log m^3 \sqrt[n]{n}$
 41. $\log_a x^{-5/2} y^4$, or $\log_a \frac{y^4}{x^{5/2}}$ 43. $\ln x$ 45. $\ln(x-2)$
 47. $\log \frac{x-7}{x-2}$ 49. $\ln \frac{x}{(x^2-25)^3}$ 51. $\ln \frac{2^{11/5} x^9}{y^8}$
 53. -0.74 55. 1.991 57. 0.356 59. 4.827
 61. -1.792 63. 0.099 65. 3 67. $|x-4|$ 69. $4x$
 71. w 73. $8t$ 75. $\frac{1}{2}$ 77. [4.1] Quartic
 78. [5.2] Exponential 79. [1.3] Linear (constant)
 80. [5.2] Exponential 81. [4.5] Rational 82. [5.3] Loga-
 rithmic 83. [4.1] Cubic 84. [4.5] Rational
 85. [1.3] Linear 86. [3.3] Quadratic 87. 4
 89. $\log_a(x^3 - y^3)$ 91. $\frac{1}{2} \log_a(x-y) - \frac{1}{2} \log_a(x+y)$
 93. 7 95. True 97. True 99. True 101. -2
 103. 3 105. $e^{-xy} = \frac{a}{b}$
 107. $\log_a \left(\frac{x + \sqrt{x^2 - 5}}{5} \cdot \frac{x - \sqrt{x^2 - 5}}{x - \sqrt{x^2 - 5}} \right)$
 $= \log_a \frac{5}{5(x - \sqrt{x^2 - 5})} = -\log_a(x - \sqrt{x^2 - 5})$

Exercise Set 5.5

1. 4 3. $\frac{3}{2}$ 5. 5.044 7. $\frac{5}{2}$ 9. $-3, \frac{1}{2}$ 11. 0.959
 13. 0 15. 0 17. 6.908 19. 84.191 21. -1.710
 23. 2.844 25. $-1.567, 1.567$ 27. 1.869
 29. $-1.518, 0.825$ 31. 625 33. 0.0001 35. e
 37. $-\frac{1}{3}$ 39. $\frac{22}{3}$ 41. 10 43. 4 45. $\frac{1}{63}$ 47. 2
 49. $\frac{2}{5}$ 51. 5 53. $\frac{21}{8}$ 55. $\frac{8}{7}$ 57. 6 59. 6.192
 61. 0 63. [3.3] (a) $(0, -6)$; (b) $x = 0$; (c) minimum:
 -6 when $x = 0$ 64. [3.3] (a) $(3, 1)$; (b) $x = 3$;
 (c) maximum: 1 when $x = 3$ 65. [3.3] (a) $(-1, -5)$;
 (b) $x = -1$; (c) maximum: -5 when $x = -1$
 66. [3.3] (a) $(2, 4)$; (b) $x = 2$; (c) minimum: 4 when
 $x = 2$ 67. 0.347 69. 10 71. 1, e^4 or 1, 54.598
 73. $\frac{1}{3}, 27$ 75. 1, e^2 or 1, 7.389 77. 0, 0.431 79. $-9, 9$
 81. e^{-2}, e^2 or 0.135, 7.389 83. $\frac{7}{4}$ 85. 5 87. -1.860 ,
 $-1.524, 1.524, 1.860$ 89. 88
 91. $f^{-1}(x) = \ln \left(\frac{x + \sqrt{x^2 + 4}}{2} \right)$

Exercise Set 5.6

1. (a) $P(t) = 6.8e^{0.0113t}$; (b) 7.0 billion; 7.7 billion;
 (c) about 14.4 yr after 2009; (d) 61.3 yr 3. (a) 0.98%;

- (b) 1.51%; (c) 21.6 yr; (d) 57.8 yr; (e) 0.28%; (f) 29.9 yr;
 (g) 49.5 yr; (h) 0.66%; (i) 2.04%; (j) 37.7 yr 5. In about
 513 yr 7. (a) $P(t) = 10,000e^{0.054t}$; (b) \$10,554.85;
 \$11,140.48; \$13,099.64; \$17,160.07; (c) about 12.8 yr
 9. About 12,320 yr 11. (a) 22.4% per minute; (b) 3.1% per
 year; (c) 60.3 days; (d) 10.7 yr; (e) 2.4% per year; (f) 1.0%
 per year; (g) 0.0029% per year 13. (a) $k \approx 0.1268$;
 $C(t) = 4.85e^{-0.1268t}$; (b) 2015: \$2.27; 2018: \$1.55;
 (c) in 2017 15. (a) $k \approx 0.2119$; $R(t) = 900e^{0.2119t}$;
 (b) \$35.9 million; (c) about 3.3 yr; (d) 48 yr after 1960, or in
 2008 17. (a) 167; (b) 500; 1758; 3007; 3449; 3495;
 (c) as $t \rightarrow \infty$, $N(t) \rightarrow 3500$; the number approaches 3500
 but never actually reaches it. 19. 46.7°F 21. 59.6°F
 23. [1.6] Multiplication principle for inequalities
 24. [5.4] Product rule 25. [3.2] Principle of zero products
 26. [3.2] Principle of square roots 27. [5.4] Power rule
 28. [1.5] Multiplication principle for equations 29. \$166.16
 31. \$14,182.70 33. $t = -\frac{L}{R} \left[\ln \left(1 - \frac{iR}{V} \right) \right]$ 35. Linear

Review Exercises: Chapter 5

1. True 2. False 3. False 4. True 5. False 6. True
 7. $\{(-2.7, 1.3), (-3, 8), (3, -5), (-3, 6), (-5, 7)\}$
 8. (a) $x = -2y + 3$; (b) $x = 3y^2 + 2y - 1$;
 (c) $0.8y^3 - 5.4x^2 = 3y$ 9. No 10. No 11. Yes
 12. Yes 13. (a) Yes; (b) $f^{-1}(x) = \frac{-x+2}{3}$ 14. (a) Yes;
 (b) $f^{-1}(x) = \frac{x+2}{x-1}$ 15. (a) Yes; (b) $f^{-1}(x) = x^2 + 6$,
 $x \geq 0$ 16. (a) Yes; (b) $f^{-1}(x) = \sqrt[3]{x+8}$ 17. (a) No
 18. (a) Yes; (b) $f^{-1}(x) = \ln x$
 19. $f^{-1}(f(x)) = f^{-1}(6x-5) = \frac{6x-5+5}{6} = \frac{6x}{6} = x$;
 $f(f^{-1}(x)) = f\left(\frac{x+5}{6}\right) = 6\left(\frac{x+5}{6}\right) - 5 = x + 5 - 5 = x$
 20. $f^{-1}(f(x)) = f^{-1}\left(\frac{x+1}{x}\right) = \frac{1}{\frac{x+1}{x} - 1} =$

$$\frac{1}{\frac{x+1}{x} - 1} = \frac{1}{\frac{1}{x}} = x; f(f^{-1}(x)) = f\left(\frac{1}{x-1}\right) =$$

$$\frac{1}{\frac{1}{x-1} + 1} = \frac{1}{\frac{1+x-1}{x-1}} = \frac{1}{\frac{x}{x-1}} = \frac{x-1}{x} \cdot \frac{x-1}{1} = x$$

21. $f^{-1}(x) = \frac{2-x}{5}$; domain

of f and f^{-1} : $(-\infty, \infty)$; range
 of f and f^{-1} : $(-\infty, \infty)$;

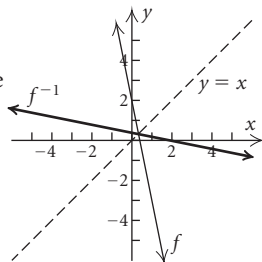

22. $f^{-1}(x) = \frac{-2x-3}{x-1}$;

domain of f : $(-\infty, -2) \cup (-2, \infty)$;
 range of f : $(-\infty, 1) \cup (1, \infty)$;
 domain of f^{-1} : $(-\infty, 1) \cup (1, \infty)$;
 range of f^{-1} : $(-\infty, -2) \cup (-2, \infty)$;

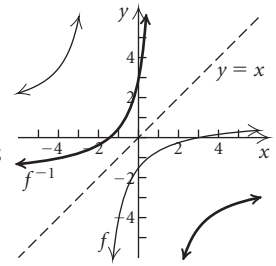

23. 657 24. a

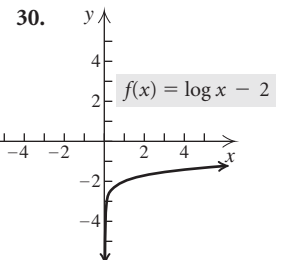
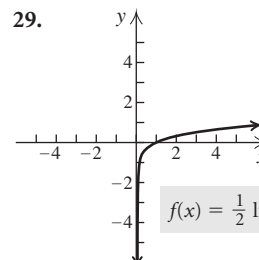
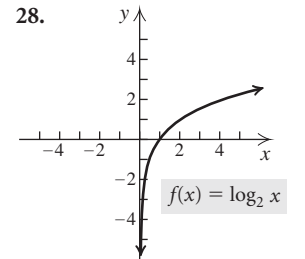
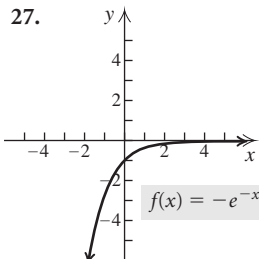
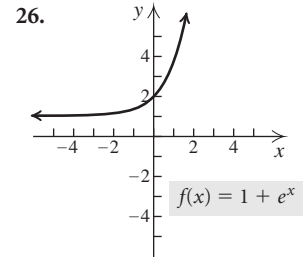
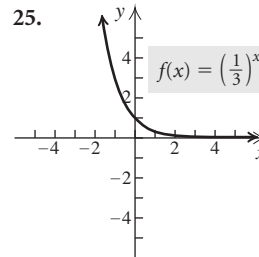

31. (c) 32. (a) 33. (b) 34. (f) 35. (e) 36. (d)
 37. 3 38. 5 39. 1 40. 0 41. $\frac{1}{4}$ 42. $\frac{1}{2}$ 43. 0
 44. 1 45. $\frac{1}{3}$ 46. -2 47. $4^2 = x$ 48. $a^k = Q$
 49. $\log_4 \frac{1}{64} = -3$ 50. $\ln 80 = x$, or $\log_e 80 = x$
 51. 1.0414 52. -0.6308 53. 1.0986 54. -3.6119
 55. Does not exist 56. Does not exist 57. 1.9746
 58. 0.5283 59. $\log_b \frac{x^3 \sqrt{z}}{y^4}$ 60. $\ln(x^2 - 4)$
 61. $\frac{1}{4} \ln w + \frac{1}{2} \ln r$ 62. $\frac{2}{3} \log M - \frac{1}{3} \log N$ 63. 0.477
 64. 1.699 65. -0.699 66. 0.233 67. $-5k$ 68. -6t
 69. 16 70. $\frac{1}{5}$ 71. 4.382 72. 2 73. $\frac{1}{2}$ 74. 5 75. 4
 76. 9 77. 1 78. 3.912 79. (a) $A(t) = 16,000(1.0105)^{4t}$;
 (b) \$16,000, \$20,588.51, \$26,415.77, \$33,941.80
 80. \$65.6 million; \$363.1 million 81. 8.1 yr 82. 2.3%
 83. About 2623 yr 84. 5.6 85. 6.3 86. 30 decibels
 87. (a) 2.2 ft/sec; (b) 8,553,143 88. (a) $k \approx 0.1492$;

(b) $S(t) = 0.035e^{0.1492t}$, where t is the number of years after 1940; (c) about \$1.459 billion; about \$128.2 billion; about \$2534 billion, or \$2.534 trillion; (d) in 2009

89. (a) $P(t) = 3.039e^{0.013t}$, where t is the number of years since 2005; (b) 3.201 million, 3.461 million; (c) in 92 yr; (d) 53.3 yr **90.** D **91.** A **92.** D **93.** B **94.** $\frac{1}{64}$, 64

95. 1 **96.** 16 **97.** $(1, \infty)$ **98.** Reflect the graph of $f(x) = \ln x$ across the line $y = x$ to obtain the graph of $h(x) = e^x$. Then shift this graph right 2 units to obtain the graph of $g(x) = e^{x-2}$. **99.** Measure the atmospheric pressure P at the top of the building. Substitute that value in the equation $P = 14.7e^{-0.00005a}$, and solve for the height, or altitude, a of the top of the building. Also measure the atmospheric pressure at the base of the building and solve for the altitude of the base. Then subtract to find the height of the building. **100.** $\log_a ab^3 \neq (\log_a a)(\log_a b^3)$. If the first step had been correct, then the second step would be as well. The correct procedure follows: $\log_a ab^3 = \log_a a + \log_a b^3 = 1 + 3\log_a b$.

101. The inverse of a function $f(x)$ is written $f^{-1}(x)$, whereas $[f(x)]^{-1}$ means $\frac{1}{f(x)}$.

Test: Chapter 5

1. [5.1] $\{(5, -2), (3, 4), (-1, 0), (-3, -6)\}$ **2.** [5.1] No
3. [5.1] Yes **4.** [5.1] (a) Yes; (b) $f^{-1}(x) = \sqrt[3]{x-1}$
5. [5.1] (a) Yes; (b) $f^{-1}(x) = 1-x$ **6.** [5.1] (a) Yes; (b) $f^{-1}(x) = \frac{2x}{1+x}$ **7.** [5.1] (a) No
- 8.** [5.1] $f^{-1}(f(x)) = f^{-1}(-4x+3) = \frac{3-(-4x+3)}{4} = \frac{4x}{4} = x$; $f(f^{-1}(x)) = f\left(\frac{3-x}{4}\right) = -4\left(\frac{3-x}{4}\right) + 3 = -3+x+3 = x$ **9.** [5.1] $f^{-1}(x) = \frac{x}{x+1}$;

domain of f : $(-\infty, 4) \cup (4, \infty)$;

range of f : $(-\infty, 0) \cup (0, \infty)$;

domain of f^{-1} : $(-\infty, 0) \cup (0, \infty)$;

range of f^{-1} : $(-\infty, 4) \cup (4, \infty)$;

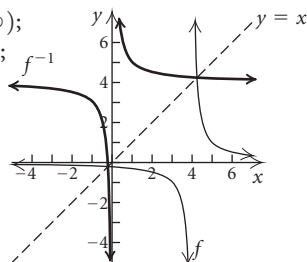

10. [5.2]

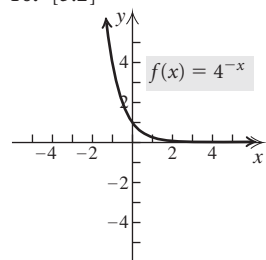

11. [5.3]

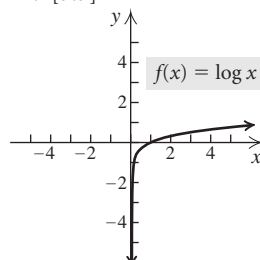

12. [5.2]

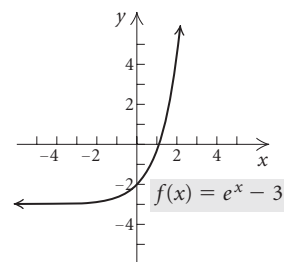

13. [5.3]

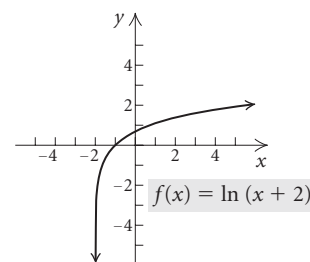

- 14.** [5.3] -5 **15.** [5.3] 1 **16.** [5.3] 0 **17.** [5.3] $\frac{1}{5}$
- 18.** [5.3] $x = e^4$ **19.** [5.3] $x = \log_3 5.4$ **20.** [5.3] 2.7726
- 21.** [5.3] -0.5331 **22.** [5.3] 1.2851 **23.** [5.4] $\log_a \frac{x^2\sqrt{z}}{y}$
- 24.** [5.4] $\frac{2}{5} \ln x + \frac{1}{5} \ln y$ **25.** [5.4] 0.656 **26.** [5.4] -4t
- 27.** [5.5] $\frac{1}{2}$ **28.** [5.5] 1 **29.** [5.5] 1 **30.** [5.5] 4.174
- 31.** [5.3] 6.6 **32.** [5.6] 0.0154 **33.** [5.6] (a) 4.5%; (b) $P(t) = 1000e^{0.045t}$; (c) \$1433.33; (d) 15.4 yr
- 34.** [5.2] C **35.** [5.5] $\frac{27}{8}$

Chapter 6

Exercise Set 6.1

1. $\sin \phi = \frac{15}{17}$, $\cos \phi = \frac{8}{17}$, $\tan \phi = \frac{15}{8}$, $\csc \phi = \frac{17}{15}$,
 $\sec \phi = \frac{17}{8}$, $\cot \phi = \frac{8}{15}$ **3.** $\sin \alpha = \frac{\sqrt{3}}{2}$, $\cos \alpha = \frac{1}{2}$,
 $\tan \alpha = \sqrt{3}$, $\csc \alpha = \frac{2\sqrt{3}}{3}$, $\sec \alpha = 2$, $\cot \alpha = \frac{\sqrt{3}}{3}$
5. $\sin \phi = \frac{27}{5\sqrt{37}}$, or $\frac{27\sqrt{37}}{185}$; $\cos \phi = \frac{14}{5\sqrt{37}}$, or $\frac{14\sqrt{37}}{185}$;
 $\tan \phi = \frac{27}{14}$; $\csc \phi = \frac{5\sqrt{37}}{27}$; $\sec \phi = \frac{5\sqrt{37}}{14}$; $\cot \phi = \frac{14}{27}$
7. $\csc \alpha = \frac{3}{\sqrt{5}}$, or $\frac{3\sqrt{5}}{5}$; $\sec \alpha = \frac{3}{2}$; $\cot \alpha = \frac{2}{\sqrt{5}}$, or $\frac{2\sqrt{5}}{5}$
9. $\cos \theta = \frac{7}{25}$, $\tan \theta = \frac{24}{7}$, $\csc \theta = \frac{25}{24}$, $\sec \theta = \frac{25}{7}$, $\cot \theta = \frac{7}{24}$
11. $\sin \phi = \frac{2\sqrt{5}}{5}$, $\cos \phi = \frac{\sqrt{5}}{5}$, $\csc \phi = \frac{\sqrt{5}}{2}$,
 $\sec \phi = \sqrt{5}$, $\cot \phi = \frac{1}{2}$ **13.** $\sin \theta = \frac{2}{3}$, $\cos \theta = \frac{\sqrt{5}}{3}$,
 $\tan \theta = \frac{2\sqrt{5}}{5}$, $\sec \theta = \frac{3\sqrt{5}}{5}$, $\cot \theta = \frac{\sqrt{5}}{2}$
15. $\sin \beta = \frac{2\sqrt{5}}{5}$, $\tan \beta = 2$, $\csc \beta = \frac{\sqrt{5}}{2}$,
 $\sec \beta = \sqrt{5}$, $\cot \beta = \frac{1}{2}$ **17.** $\frac{\sqrt{2}}{2}$ **19.** 2 **21.** $\frac{\sqrt{3}}{3}$
- 23.** $\frac{1}{2}$ **25.** 1 **27.** 2 **29.** 22.6 ft **31.** 9.72° **33.** 35.01°
- 35.** 3.03° **37.** 49.65° **39.** 0.25° **41.** 5.01°
- 43.** $17^\circ 36'$ **45.** $83^\circ 1' 30''$ **47.** $11^\circ 45'$ **49.** $47^\circ 49' 36''$
- 51.** $0^\circ 54'$ **53.** $39^\circ 27'$ **55.** 0.6293 **57.** 0.0737
- 59.** 1.2765 **61.** 0.7621 **63.** 0.9336 **65.** 12.4288
- 67.** 1.0000 **69.** 1.7032 **71.** 30.8° **73.** 12.5°
- 75.** 64.4° **77.** 46.5° **79.** 25.2° **81.** 38.6° **83.** 45°

85. 60° 87. 45° 89. 60° 91. 30°

93. $\cos 20^\circ = \sin 70^\circ = \frac{1}{\sec 20^\circ}$

95. $\tan 52^\circ = \cot 38^\circ = \frac{1}{\cot 52^\circ}$

97. $\sin 25^\circ \approx 0.4226$, $\cos 25^\circ \approx 0.9063$, $\tan 25^\circ \approx 0.4663$,
 $\csc 25^\circ \approx 2.3662$, $\sec 25^\circ \approx 1.1034$, $\cot 25^\circ \approx 2.1445$

99. $\sin 18^\circ 49' 55'' \approx 0.3228$, $\cos 18^\circ 49' 55'' \approx 0.9465$,
 $\tan 18^\circ 49' 55'' \approx 0.3411$, $\csc 18^\circ 49' 55'' \approx 3.0979$,
 $\sec 18^\circ 49' 55'' \approx 1.0565$, $\cot 18^\circ 49' 55'' \approx 2.9317$

101. $\sin 8^\circ = q$, $\cos 8^\circ = p$, $\tan 8^\circ = \frac{1}{r}$, $\csc 8^\circ = \frac{1}{q}$,

$\sec 8^\circ = \frac{1}{p}$, $\cot 8^\circ = r$

102. [5.2]

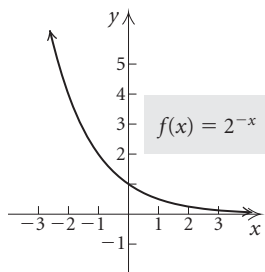

103. [5.2]

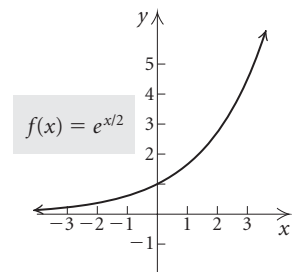

104. [5.3]

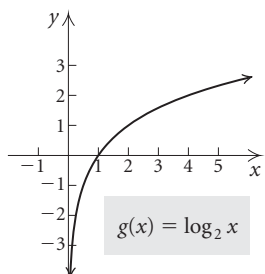

105. [5.3]

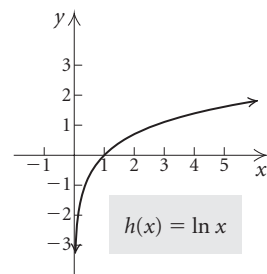

106. [5.5] 9.21 107. [5.5] 4

108. [5.5] $\frac{101}{97}$

109. [5.5] 343 111. 0.6534 113. Area = $\frac{1}{2}ab$. But
 $a = c \sin A$, so Area = $\frac{1}{2}bc \sin A$.

Exercise Set 6.2

1. $F = 60^\circ$, $d = 3$, $f \approx 5.2$ 3. $A = 22.7^\circ$, $a \approx 52.7$,
 $c \approx 136.6$ 5. $P = 47^\circ 38'$, $n \approx 34.4$, $p \approx 25.4$
 7. $B = 2^\circ 17'$, $b \approx 0.39$, $c \approx 9.74$ 9. $A \approx 77.2^\circ$, $B \approx 12.8^\circ$,
 $a \approx 439$ 11. $B = 42.42^\circ$, $a \approx 35.7$, $b \approx 32.6$
 13. $B = 55^\circ$, $a \approx 28.0$, $c \approx 48.8$ 15. $A \approx 62.4^\circ$, $B \approx 27.6^\circ$,
 $a \approx 3.56$ 17. Approximately 34° 19. About 13.9°
 21. 154 in., or 12 ft 10 in. 23. 401 ft 25. About 424 ft
 27. About 92.9 cm 29. About 45 ft 31. Radius: 9.15 in.;
 length: 73.20 in.; width: 54.90 in. 33. 17.9 ft
 35. About 8 km 37. About 19.5 mi 39. About 24 km
 40. [1.1] $3\sqrt{10}$, or about 9.487 41. [1.1] $10\sqrt{2}$,
 or about 14.142 42. [5.3] $\ln t = 4$ 43. [5.3] $10^{-3} = 0.001$
 45. 3.3 47. $\theta \approx 27^\circ$

Exercise Set 6.3

1. III 3. III 5. I 7. III 9. II 11. II
 13. 434° , 794° , -286° , -646° 15. 475.3° , 835.3° ,
 -244.7° , -604.7° 17. 180° , 540° , -540° , -900°
 19. 72.89° , 162.89° 21. $77^\circ 56' 46''$, $167^\circ 56' 46''$
 23. 44.8° , 134.8° 25. $\sin \beta = \frac{5}{13}$, $\cos \beta = -\frac{12}{13}$,
 $\tan \beta = -\frac{5}{12}$, $\csc \beta = \frac{13}{5}$, $\sec \beta = -\frac{13}{12}$, $\cot \beta = -\frac{12}{5}$
 27. $\sin \phi = -\frac{2\sqrt{7}}{7}$, $\cos \phi = -\frac{\sqrt{21}}{7}$, $\tan \phi = \frac{2\sqrt{3}}{3}$,
 $\csc \phi = -\frac{\sqrt{7}}{2}$, $\sec \phi = -\frac{\sqrt{21}}{3}$, $\cot \phi = \frac{\sqrt{3}}{2}$
 29. $\sin \theta = -\frac{2\sqrt{13}}{13}$, $\cos \theta = \frac{3\sqrt{13}}{13}$, $\tan \theta = -\frac{2}{3}$
 31. $\sin \theta = \frac{5\sqrt{41}}{41}$, $\cos \theta = \frac{4\sqrt{41}}{41}$, $\tan \theta = \frac{5}{4}$
 33. $\cos \theta = -\frac{2\sqrt{2}}{3}$, $\tan \theta = \frac{\sqrt{2}}{4}$, $\csc \theta = -3$,
 $\sec \theta = -\frac{3\sqrt{2}}{4}$, $\cot \theta = 2\sqrt{2}$ 35. $\sin \theta = -\frac{\sqrt{5}}{5}$,
 $\cos \theta = \frac{2\sqrt{5}}{5}$, $\tan \theta = -\frac{1}{2}$, $\csc \theta = -\sqrt{5}$, $\sec \theta = \frac{\sqrt{5}}{2}$
 37. $\sin \phi = -\frac{4}{5}$, $\tan \phi = -\frac{4}{3}$, $\csc \phi = -\frac{5}{4}$, $\sec \phi = \frac{5}{3}$,
 $\cot \phi = -\frac{3}{4}$ 39. 30° ; $-\frac{\sqrt{3}}{2}$ 41. 45° ; 1 43. 0
 45. 45° ; $-\frac{\sqrt{2}}{2}$ 47. 30° ; 2 49. 30° ; $\sqrt{3}$ 51. 30° ; $-\frac{\sqrt{3}}{3}$
 53. Not defined 55. -1 57. 60° ; $\sqrt{3}$
 59. 45° ; $\frac{\sqrt{2}}{2}$ 61. 45° ; $-\sqrt{2}$ 63. 1 65. 0 67. 0
 69. 0 71. Positive: cos, sec; negative: sin, csc, tan, cot
 73. Positive: tan, cot; negative: sin, csc, cos, sec 75. Positive:
 sin, csc; negative: cos, sec, tan, cot 77. Positive: all
 79. $\sin 319^\circ = -0.6561$, $\cos 319^\circ = 0.7547$,
 $\tan 319^\circ = -0.8693$, $\csc 319^\circ \approx -1.5242$,
 $\sec 319^\circ \approx 1.3250$, $\cot 319^\circ \approx -1.1504$
 81. $\sin 115^\circ = 0.9063$, $\cos 115^\circ = -0.4226$,
 $\tan 115^\circ = -2.1445$, $\csc 115^\circ \approx 1.1034$,
 $\sec 115^\circ \approx -2.3663$, $\cot 115^\circ \approx -0.4663$ 83. East: about
 130 km; south: 75 km 85. About 223 km
 87. -1.1585 89. -1.4910 91. 0.8771
 93. 0.4352 95. 0.9563 97. 2.9238 99. 275.4°
 101. 200.1° 103. 288.1° 105. 72.6°
 107. [4.5]

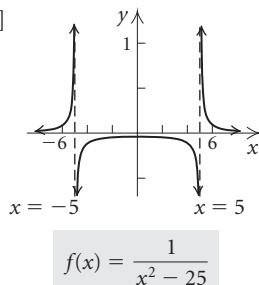

108. [4.2]

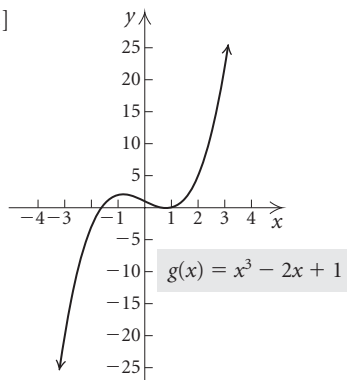

109. [1.2], [4.5] Domain: $\{x \mid x \neq -2\}$; range: $\{y \mid y \neq 1\}$

110. [1.2], [4.1], [4.5] Domain: $\{x \mid x \neq -\frac{3}{2} \text{ and } x \neq 5\}$; range: all real numbers

111. [1.5] 12 112. [3.2] $-2, 3$

113. [1.5] (12, 0) 114. [3.2] $(-2, 0), (3, 0)$ 115. 19.625 in.

Mid-Chapter Mixed Review: Chapter 6

1. True 2. True 3. True 4. $S = 47.5^\circ, s \approx 59.9, q \approx 54.9$ 5. $A \approx 27.8^\circ, B \approx 62.2^\circ, b \approx 27.2$

6. $285^\circ, 645^\circ; -435^\circ, -1155^\circ$ 7. $574^\circ 30', 1294^\circ 30'; -145^\circ 30', -505^\circ 30'$ 8. $71.8^\circ; 161.8^\circ$ 9. $2^\circ 44' 50''; 92^\circ 44' 50''$ 10. $\sin 155^\circ = 0.4226, \cos 155^\circ = -0.9063,$
 $\tan 155^\circ = -0.4663, \csc 155^\circ = 2.3663,$

$\sec 155^\circ = -1.1034, \cot 155^\circ = -2.1445$ 11. $\sin \alpha = -\frac{5}{13},$
 $\cos \alpha = -\frac{12}{13}, \tan \alpha = \frac{5}{12}, \csc \alpha = -\frac{13}{5}, \sec \alpha = -\frac{13}{12},$

$\cot \alpha = \frac{12}{5}$ 12. $\sin \theta = -\frac{1}{\sqrt{5}},$ or $-\frac{\sqrt{5}}{5}; \cos \theta = -\frac{2}{\sqrt{5}},$

or $-\frac{2\sqrt{5}}{5}; \tan \theta = \frac{1}{2}; \csc \theta = -\sqrt{5}; \sec \theta = -\frac{\sqrt{5}}{2}$

13. $\sin \alpha = \frac{\sqrt{77}}{9}; \tan \alpha = \frac{\sqrt{77}}{2}; \csc \alpha = \frac{9}{\sqrt{77}},$

or $\frac{9\sqrt{77}}{77}; \sec \alpha = \frac{9}{2}; \cot \alpha = \frac{2}{\sqrt{77}},$ or $\frac{2\sqrt{77}}{77}$

14. 42.1472° 15. $51^\circ 10' 48''$ 16. $\sin 81^\circ \approx 0.9877,$
 $\cos 81^\circ \approx 0.1564, \tan 81^\circ \approx 6.3131, \csc 81^\circ \approx 1.0125,$
 $\sec 81^\circ \approx 6.3939, \cot 81^\circ \approx 0.1584$ 17. 67.5°

18. About 290 mi 19. $\frac{\sqrt{3}}{3}$ 20. $\frac{\sqrt{2}}{2}$ 21. $\sqrt{3}$

22. $-\sqrt{2}$ 23. $\frac{\sqrt{2}}{2}$ 24. -2 25. 1 26. 0

27. $\frac{\sqrt{3}}{2}$ 28. -1 29. $-\sqrt{3}$ 30. 1 31. $\frac{1}{2}$

32. $\sqrt{2}$ 33. $-\frac{\sqrt{3}}{2}$ 34. Not defined 35. 2

36. Not defined 37. 1 38. $-\frac{\sqrt{2}}{2}$ 39. 0.7683

40. 1.5557 41. 0.4245 42. 0.1817 43. -1.0403

44. -1.3127 45. -0.6441 46. 0.0480 47. Given points P and Q on the terminal side of an angle θ , the reference triangles determined by them are similar. Thus corresponding

sides are proportional and the trigonometric ratios are the same. See the specific example on p. 509. 48. If f and g are

reciprocal functions, then $f(\theta) = \frac{1}{g(\theta)}$. If f and g are

cofunctions, then $f(\theta) = g(90^\circ - \theta)$. 49. Sine: (0, 1); cosine: (0, 1); tangent: $(0, \infty)$ 50. Since $\sin \theta = y/r$ and $\cos \theta = x/r$ and $r > 0$ for all angles θ , the domain of the sine function and the cosine function is the set of all angles θ . How-

ever, $\tan \theta = y/x$ and $x = 0$ for all angles that are odd multiples of 90° . Thus the domain of the tangent function must be restricted to avoid division by 0.

Exercise Set 6.4

1.

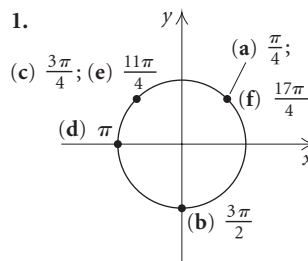

3.

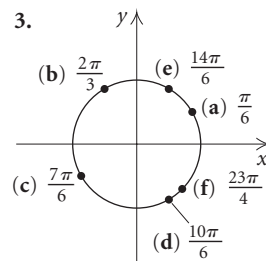

5. $M: \frac{2\pi}{3}, -\frac{4\pi}{3}; N: \frac{3\pi}{2}, -\frac{\pi}{2}; P: \frac{5\pi}{4}, -\frac{3\pi}{4}; Q: \frac{11\pi}{6}, -\frac{\pi}{6}$

7.

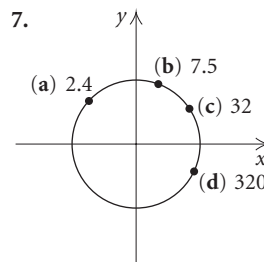

9. $\frac{9\pi}{4}, -\frac{7\pi}{4}$ 11. $\frac{19\pi}{6}, -\frac{5\pi}{6}$

13. $\frac{4\pi}{3}, -\frac{8\pi}{3}$

15. Complement: $\frac{\pi}{6}$; supplement: $\frac{2\pi}{3}$ 17. Complement: $\frac{\pi}{8}$;

supplement: $\frac{5\pi}{8}$ 19. Complement: $\frac{5\pi}{12}$; supplement: $\frac{11\pi}{12}$

21. $\frac{5\pi}{12}$ 23. $\frac{10\pi}{9}$ 25. $-\frac{214.6\pi}{180},$ or $-\frac{1073\pi}{900}$

27. $-\pi$ 29. $\frac{12.5\pi}{180},$ or $\frac{5\pi}{72}$ 31. $-\frac{17\pi}{9}$ 33. 4.19

35. -1.05 37. 2.06 39. 0.02 41. 6.02 43. 1.66

45. -135° 47. 1440° 49. 57.30° 51. 134.47°

53. 225° 55. -5156.62° 57. 51.43°

59. $0^\circ = 0$ radians, $30^\circ = \frac{\pi}{6}, 45^\circ = \frac{\pi}{4}, 60^\circ = \frac{\pi}{3},$

$90^\circ = \frac{\pi}{2}, 135^\circ = \frac{3\pi}{4}, 180^\circ = \pi, 225^\circ = \frac{5\pi}{4}, 270^\circ = \frac{3\pi}{2},$

$315^\circ = \frac{7\pi}{4}, 360^\circ = 2\pi$ 61. 2.29 63. 5.50 in.

65. 1.1; 63° 67. 3.2 yd 69. 4581 71. $3150 \frac{\text{cm}}{\text{min}}$

73. 0.92 mph 75. 1047 mph 77. 18,812 revolutions/hr
 79. About 202 80. [5.1] One-to-one 81. [6.1] Cosine of θ
 82. [5.2] Exponential function 83. [4.5] Horizontal asymptote
 84. [2.4] Odd function 85. [5.3] Natural
 86. [5.1] Horizontal line; inverse 87. [5.3] Logarithm
 89. 111.7 km; 69.8 mi 91. (a) $5^\circ 37' 30''$; (b) $19^\circ 41' 15''$
 93. 1.676 radians/sec 95. 1.46 nautical miles

Exercise Set 6.5

1. (a) $\left(-\frac{3}{4}, -\frac{\sqrt{7}}{4}\right)$; (b) $\left(\frac{3}{4}, \frac{\sqrt{7}}{4}\right)$; (c) $\left(\frac{3}{4}, -\frac{\sqrt{7}}{4}\right)$
 3. (a) $\left(\frac{2}{5}, \frac{\sqrt{21}}{5}\right)$; (b) $\left(-\frac{2}{5}, -\frac{\sqrt{21}}{5}\right)$; (c) $\left(-\frac{2}{5}, \frac{\sqrt{21}}{5}\right)$
 5. $\left(\frac{\sqrt{2}}{2}, -\frac{\sqrt{2}}{2}\right)$ 7. 0 9. $\sqrt{3}$ 11. 0 13. $-\frac{\sqrt{3}}{2}$
 15. Not defined 17. $\frac{\sqrt{3}}{2}$ 19. $-\frac{\sqrt{2}}{2}$ 21. 0 23. 0
 25. 0.4816 27. 1.3065 29. -2.1599 31. 1
 33. -1.1747 35. -1 37. -0.7071 39. 0 41. 0.8391
 43. (a)

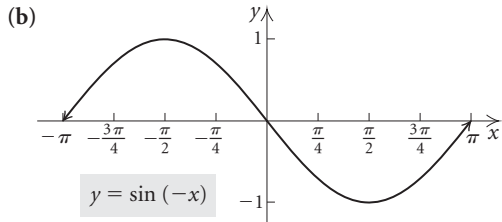
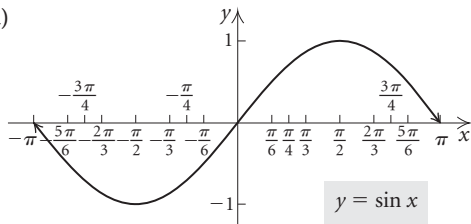

(c) same as (b); (d) the same

45. (a) See Exercise 43(a);

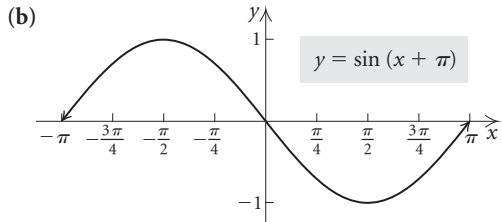

(c) same as (b); (d) the same

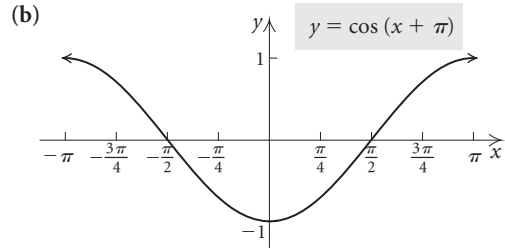
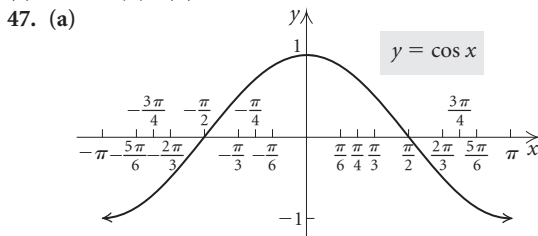

(c) same as (b); (d) the same

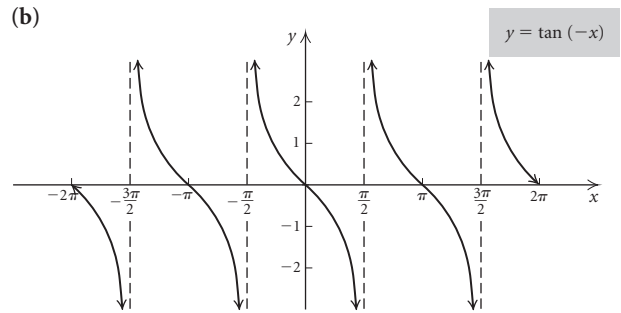
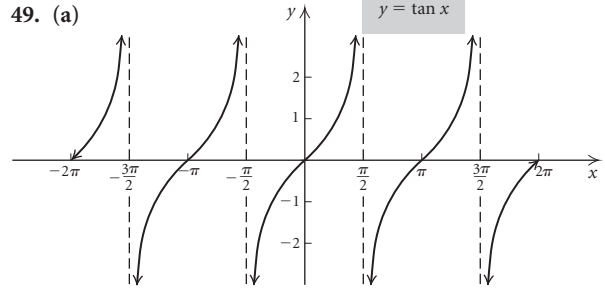

(c) same as (b); (d) the same 51. Even: cosine, secant; odd:

sine, tangent, cosecant, cotangent 53. Positive: I, III;

negative: II, IV 55. Positive: I, IV; negative: II, III

57. [2.4]

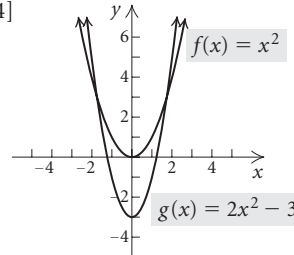

Stretch the graph of f vertically, then shift it down 3 units.

58. [2.4]

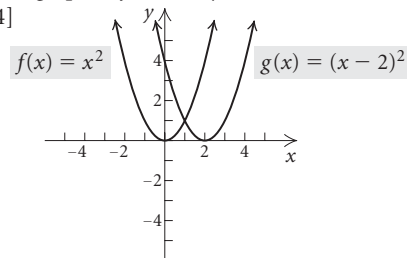

Shift the graph of f right 2 units.

59. [2.4]

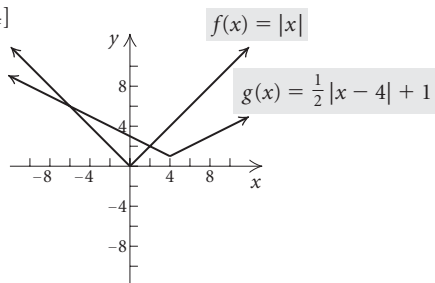

Shift the graph of f to the right 4 units, shrink it vertically, then shift it up 1 unit.

60. [2.4]

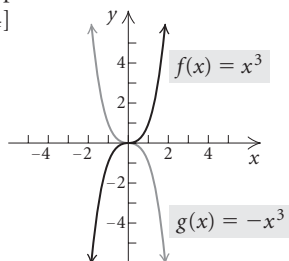

Reflect the graph of f across the x -axis.

61. [2.4] $y = -(x - 2)^3 - 1$ 62. [2.4] $y = \frac{1}{4x} + 3$

63. $\cos x$ 65. $\sin x$ 67. $\sin x$ 69. $-\cos x$

71. $-\sin x$ 73. (a) $\frac{\pi}{2} + 2k\pi, k \in \mathbb{Z}$;

(b) $\pi + 2k\pi, k \in \mathbb{Z}$; (c) $k\pi, k \in \mathbb{Z}$

75. $\left[-\frac{\pi}{2} + 2k\pi, \frac{\pi}{2} + 2k\pi\right], k \in \mathbb{Z}$

77. $\left\{x \mid x \neq \frac{\pi}{2} + k\pi, k \in \mathbb{Z}\right\}$

79.

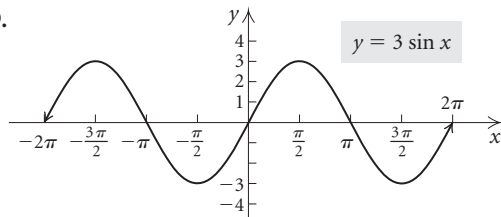

81.

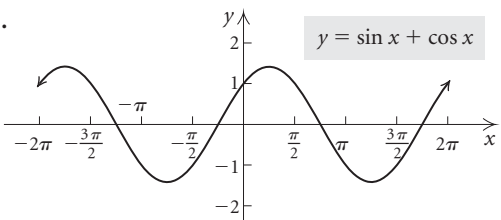

83. (a) $\triangle OPA \sim \triangle ODB$;

Thus, $\frac{AP}{OA} = \frac{BD}{OB}$
 $\frac{\sin \theta}{\cos \theta} = \frac{BD}{1}$
 $\tan \theta = BD$

(b) $\triangle OPA \sim \triangle ODB$;

$\frac{OD}{OP} = \frac{OB}{OA}$
 $\frac{OD}{1} = \frac{1}{\cos \theta}$
 $OD = \sec \theta$

(c) $\triangle OAP \sim \triangle ECO$;

$\frac{OE}{PO} = \frac{CO}{AP}$
 $\frac{OE}{1} = \frac{1}{\sin \theta}$
 $OE = \csc \theta$

(d) $\triangle OAP \sim \triangle ECO$

$\frac{CE}{AO} = \frac{CO}{AP}$
 $\frac{CE}{1} = \frac{1}{\sin \theta}$
 $CE = \frac{\cos \theta}{\sin \theta}$
 $CE = \cot \theta$

Visualizing the Graph

1. J 2. H 3. E 4. F 5. B 6. D 7. G
 8. A 9. C 10. I

Exercise Set 6.6

1. Amplitude: 1; period: 2π ; phase shift: 0

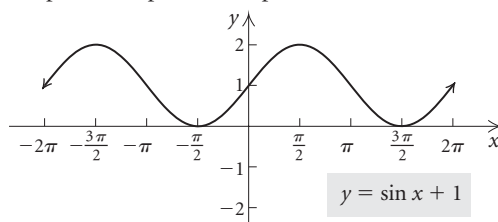

3. Amplitude: 3; period: 2π ; phase shift: 0

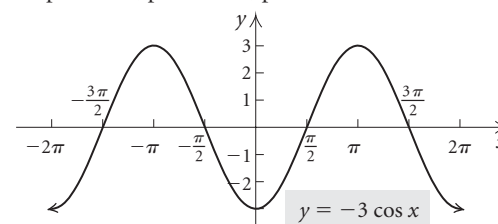

5. Amplitude: $\frac{1}{2}$; period: 2π ; phase shift: 0

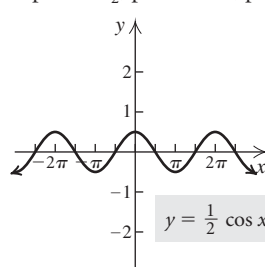

7. Amplitude: 1; period: π ; phase shift: 0

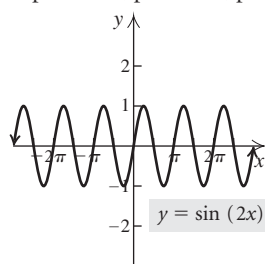

9. Amplitude: 2; period: 4π ; phase shift: 0

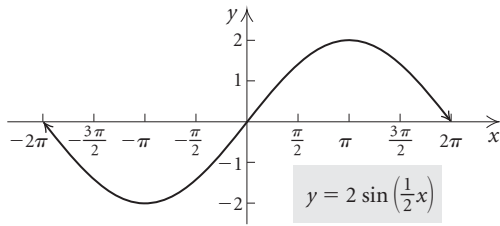

11. Amplitude: $\frac{1}{2}$; period: 2π ; phase shift: $-\frac{\pi}{2}$

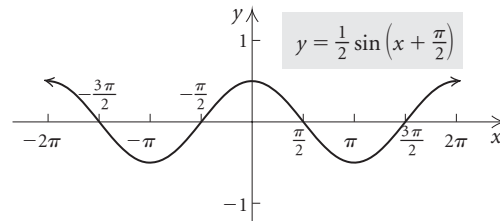

13. Amplitude: 3; period: 2π ; phase shift: π

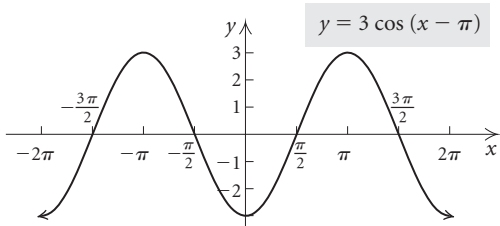

15. Amplitude: $\frac{1}{3}$; period: 2π ; phase shift: 0

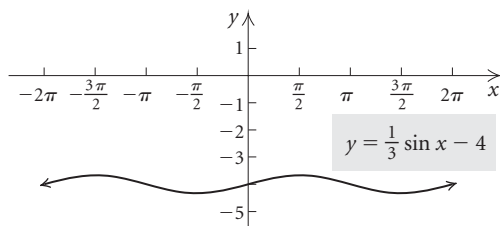

17. Amplitude: 1; period: 2π ; phase shift: 0

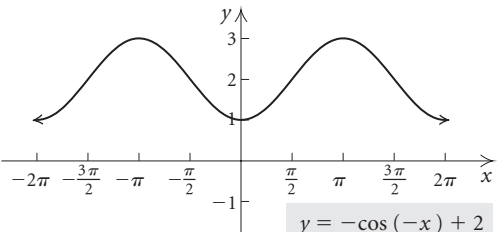

19. Amplitude: 2; period: 4π ; phase shift: π 21. Amplitude:

$\frac{1}{2}$; period: π ; phase shift: $-\frac{\pi}{4}$ 23. Amplitude: 3; period: 2;

phase shift: $\frac{3}{\pi}$ 25. Amplitude: $\frac{1}{2}$; period: 1; phase shift: 0

27. Amplitude: 1; period: 4π ; phase shift: π 29. Amplitude: 1;

period: 1; phase shift: 0 31. Amplitude: $\frac{1}{4}$; period: 2;

phase shift: $\frac{4}{\pi}$ 33. (b) 35. (h) 37. (a) 39. (f)

41. $y = \frac{1}{2} \cos x + 1$ 43. $y = \cos\left(x + \frac{\pi}{2}\right) - 2$

45.

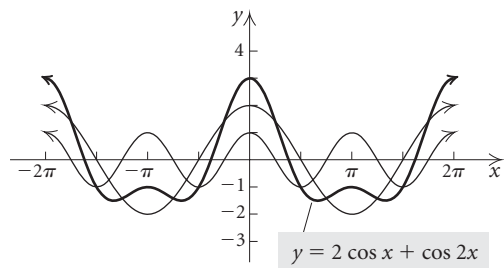

47.

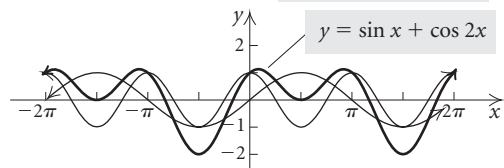

49.

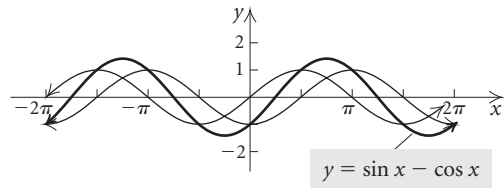

51.

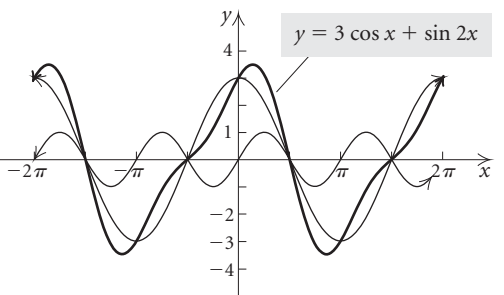

53.

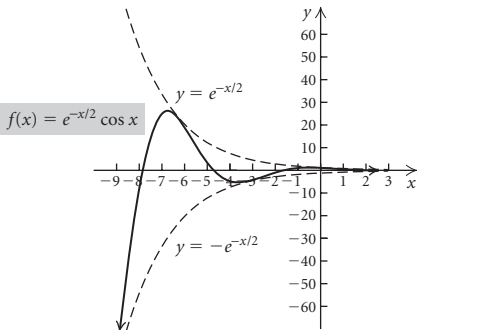

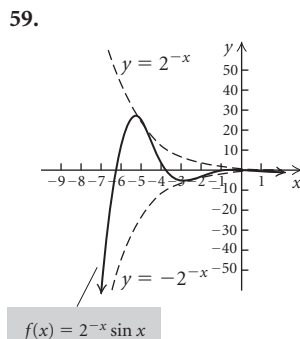
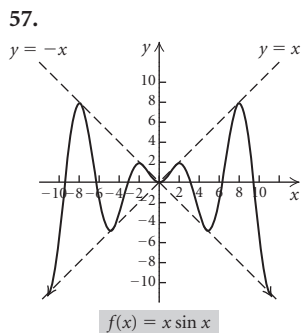
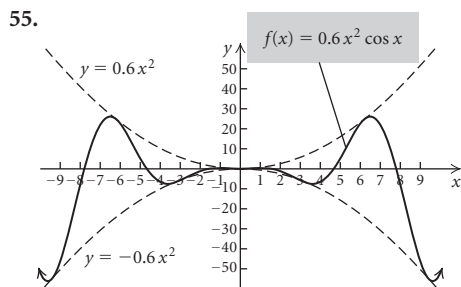

61. [4.5] Rational 62. [5.3] Logarithmic
 63. [4.1] Quartic 64. [1.3] Linear
 65. [6.6] Trigonometric 66. [5.2] Exponential
 67. [1.3] Linear 68. [6.6] Trigonometric
 69. [4.1] Cubic 70. [5.2] Exponential
 71. Maximum: 8; minimum: 4

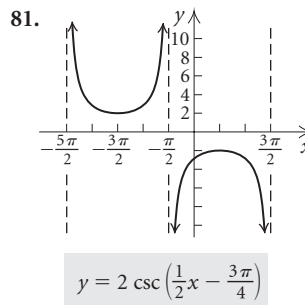
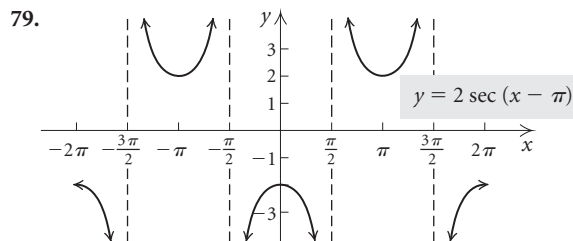
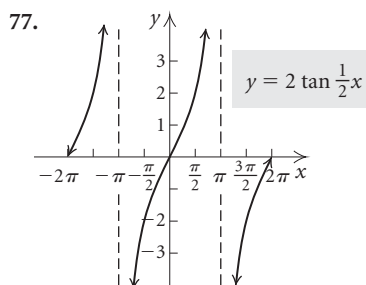
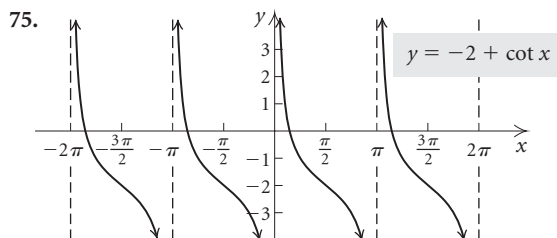
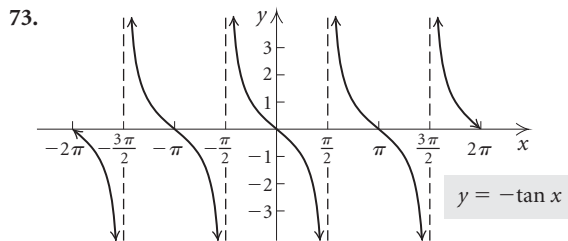

83. Amplitude: 3000; period: 90; phase shift: 10 85. 4 in.

Review Exercises: Chapter 6

1. False 2. False 3. True 4. True 5. False
 6. False 7. $\sin \theta = \frac{3\sqrt{73}}{73}$, $\cos \theta = \frac{8\sqrt{73}}{73}$, $\tan \theta = \frac{3}{8}$,
 $\csc \theta = \frac{\sqrt{73}}{3}$, $\sec \theta = \frac{\sqrt{73}}{8}$, $\cot \theta = \frac{8}{3}$
 8. $\cos \beta = \frac{3}{10}$, $\tan \beta = \frac{\sqrt{91}}{3}$, $\csc \beta = \frac{10\sqrt{91}}{91}$,
 $\sec \beta = \frac{10}{3}$, $\cot \beta = \frac{3\sqrt{91}}{91}$ 9. $\frac{\sqrt{2}}{2}$ 10. $\frac{\sqrt{3}}{3}$
 11. $-\frac{\sqrt{2}}{2}$ 12. $\frac{1}{2}$ 13. Not defined 14. $-\sqrt{3}$
 15. $\frac{2\sqrt{3}}{3}$ 16. -1 17. 22°16'12" 18. 47.56°
 19. 0.4452 20. 1.1315 21. 0.9498 22. -0.9092
 23. -1.5282 24. -0.2778 25. 205.3° 26. 47.2°
 27. 60° 28. 60° 29. 45° 30. 30°
 31. $\sin 30.9^\circ \approx 0.5135$, $\cos 30.9^\circ \approx 0.8581$,
 $\tan 30.9^\circ \approx 0.5985$, $\csc 30.9^\circ \approx 1.9474$, $\sec 30.9^\circ \approx 1.1654$,
 $\cot 30.9^\circ \approx 1.6709$ 32. $b \approx 4.5$, $A \approx 58.1^\circ$, $B \approx 31.9^\circ$
 33. $A = 38.83^\circ$, $b \approx 37.9$, $c \approx 48.6$ 34. 1748 m
 35. 14 ft 36. II 37. I 38. IV 39. 425°, -295°
 40. $\frac{\pi}{3}$, $-\frac{5\pi}{3}$ 41. Complement: 76.6°; supplement: 166.6°
 42. Complement: $\frac{\pi}{3}$; supplement: $\frac{5\pi}{6}$
 43. $\sin \theta = \frac{3\sqrt{13}}{13}$, $\cos \theta = \frac{-2\sqrt{13}}{13}$, $\tan \theta = -\frac{3}{2}$,
 $\csc \theta = \frac{\sqrt{13}}{3}$, $\sec \theta = -\frac{\sqrt{13}}{2}$, $\cot \theta = -\frac{2}{3}$
 44. $\sin \theta = -\frac{2}{3}$, $\cos \theta = -\frac{\sqrt{5}}{3}$, $\cot \theta = \frac{\sqrt{5}}{2}$,
 $\sec \theta = -\frac{3\sqrt{5}}{5}$, $\csc \theta = -\frac{3}{2}$ 45. About 1743 mi

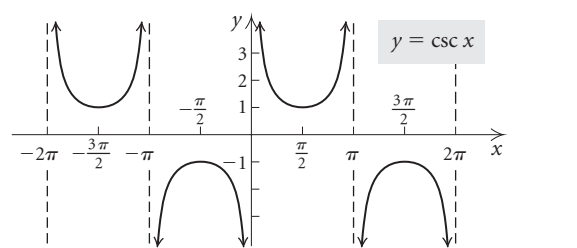
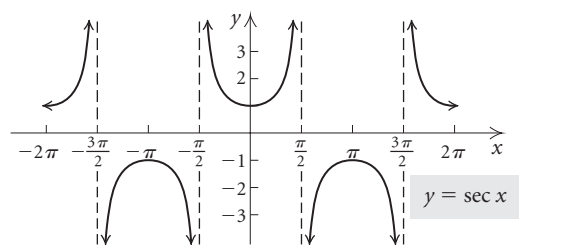
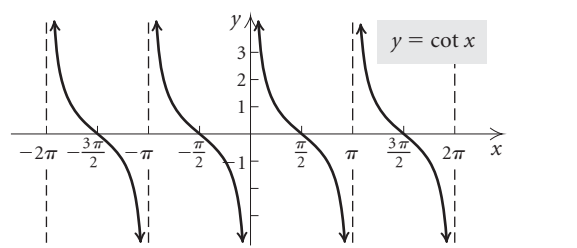
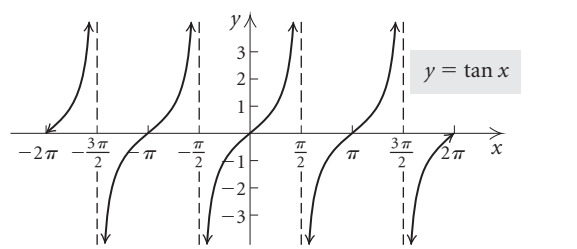
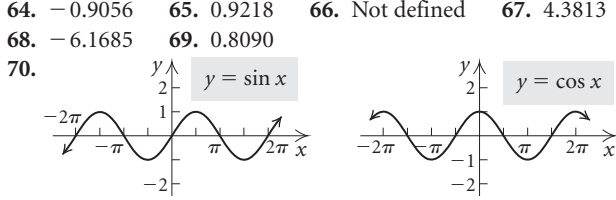
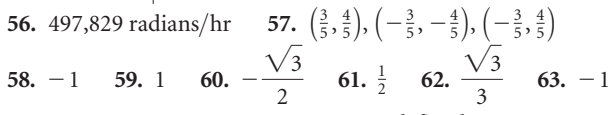
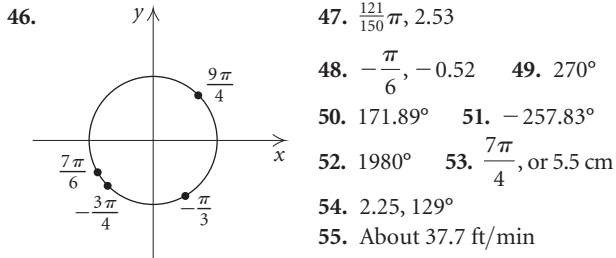

71. Period of sin, cos, sec, csc: 2π ; period of tan, cot: π
 72.

Function	Domain	Range
Sine	$(-\infty, \infty)$	$[-1, 1]$
Cosine	$(-\infty, \infty)$	$[-1, 1]$
Tangent	$\{x \mid x \neq \frac{\pi}{2} + k\pi, k \in \mathbb{Z}\}$	$(-\infty, \infty)$

73.

Function	I	II	III	IV
Sine	+	+	-	-
Cosine	+	-	-	+
Tangent	+	-	+	-

74. Amplitude: 1; period: 2π ; phase shift: $-\frac{\pi}{2}$

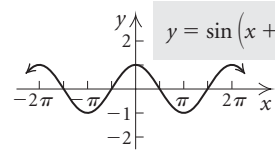

75. Amplitude: $\frac{1}{2}$; period: π ; phase shift: $\frac{\pi}{4}$

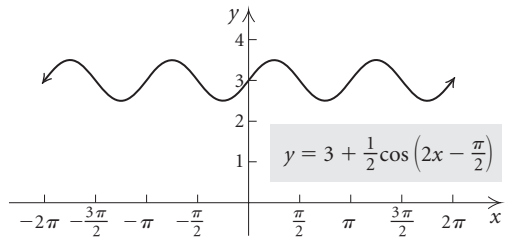

76. (d) 77. (a) 78. (c) 79. (b)
 80.

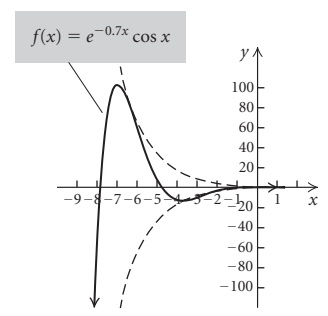
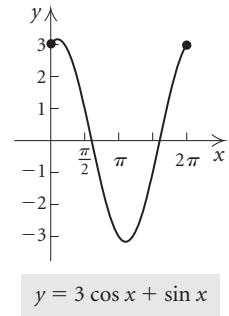

82. C 83. B 84. B

85. Domain: $(-\infty, \infty)$; range: $[-3, 3]$; period 4π

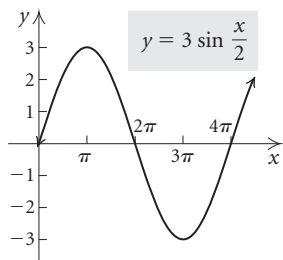

86. $y_2 = 2 \sin\left(x + \frac{\pi}{2}\right) - 2$ 87. The domain consists

of the intervals $\left(-\frac{\pi}{2} + 2k\pi, \frac{\pi}{2} + 2k\pi\right)$, $k \in \mathbb{Z}$.

88. $\cos x = -0.7890$, $\tan x = -0.7787$,
 $\cot x = -1.2842$, $\sec x = -1.2674$, $\csc x = 1.6276$

89. Both degrees and radians are units of angle measure.

Degree notation has been in use since Babylonian times.

A degree is defined to be $\frac{1}{360}$ of one complete positive revolution. Radians are defined in terms of intercepted arc length on a circle, with one radian being the measure of the angle for which the arc length equals the radius. There are 2π radians in one complete revolution. 90. For a point at a distance r from the center of rotation with a fixed angular speed k , the linear speed

is given by $v = r \cdot k$, or $r = \frac{1}{k}v$. Thus the length of the radius is

directly proportional to the linear speed. 91. The numbers

for which the value of the cosine function is 0 are not in the domain of the tangent function. 92. The denominator B in the phase shift C/B serves to shrink or stretch the translation of C units by the same factor as the horizontal shrinking or stretching of the period. Thus the translation must be done after the horizontal shrinking or stretching. For example, consider $y = \sin(2x - \pi)$. The phase shift of this function is $\pi/2$. First translate the graph of $y = \sin x$ to the right $\pi/2$ units and then shrink it horizontally by a factor of 2. Compare this graph with the one formed by first shrinking the graph of $y = \sin x$ horizontally by a factor of 2 and then translating it to the right $\pi/2$ units. The graphs differ; the second one is correct. 93. The constants B , C , and D translate the graphs, and the constants A and B stretch or shrink the graphs. See the chart on p. 559 for a complete description of the effect of each constant. 94. We see from the formula $\theta = \frac{s}{r}$ that the tire

with the 15-in. diameter will rotate through a larger angle than the tire with the 16-in. diameter. Thus the car with the 15-in. tires will probably need new tires first.

Test: Chapter 6

1. [6.1] $\sin \theta = \frac{4}{\sqrt{65}}$, or $\frac{4\sqrt{65}}{65}$; $\cos \theta = \frac{7}{\sqrt{65}}$, or $\frac{7\sqrt{65}}{65}$;
 $\tan \theta = \frac{4}{7}$; $\csc \theta = \frac{\sqrt{65}}{4}$; $\sec \theta = \frac{\sqrt{65}}{7}$; $\cot \theta = \frac{7}{4}$

2. [6.3] $\frac{\sqrt{3}}{2}$ 3. [6.3] -1 4. [6.4] -1 5. [6.4] $-\sqrt{2}$

6. [6.1] 38.47° 7. [6.3] -0.2419 8. [6.3] -0.2079

9. [6.4] -5.7588 10. [6.4] 0.7827 11. [6.1] 30°

12. [6.1] $\sin 61.6^\circ \approx 0.8796$; $\cos 61.6^\circ \approx 0.4756$;

$\tan 61.6^\circ \approx 1.8495$; $\csc 61.6^\circ \approx 1.1369$;

$\sec 61.6^\circ \approx 2.1026$; $\cot 61.6^\circ \approx 0.5407$

13. [6.2] $B = 54.1^\circ$, $a \approx 32.6$, $c \approx 55.7$ 14. [6.3] Answers

may vary; 472° , -248° 15. [6.4] $\frac{\pi}{6}$

16. [6.3] $\cos \theta = \frac{5}{\sqrt{41}}$, or $\frac{5\sqrt{41}}{41}$; $\tan \theta = -\frac{4}{5}$;

$\csc \theta = -\frac{\sqrt{41}}{4}$; $\sec \theta = \frac{\sqrt{41}}{5}$; $\cot \theta = -\frac{5}{4}$ 17. [6.4] $\frac{7\pi}{6}$

18. [6.4] 135° 19. [6.4] $\frac{16\pi}{3} \approx 16.755$ cm 20. [6.6] 1

21. [6.6] 2π 22. [6.6] $\frac{\pi}{2}$ 23. [6.6] (c)

24. [6.2] About 10.4° 25. [6.2] About 272 mi

26. [6.4] $18\pi \approx 56.55$ m/min

27. [6.6]

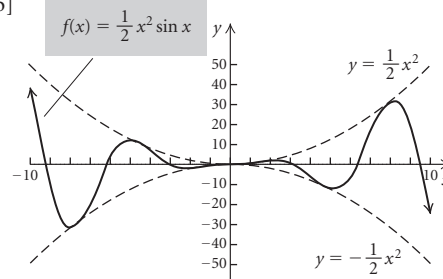

28. [6.6] C

29. [6.5] $\left\{x \mid -\frac{\pi}{2} + 2k\pi < x < \frac{\pi}{2} + 2k\pi, k \text{ an integer}\right\}$

Chapter 7

Exercise Set 7.1

1. $\sin^2 x - \cos^2 x$ 3. $\sin y + \cos y$ 5. $1 - 2 \sin \phi \cos \phi$

7. $\sin^3 x + \csc^3 x$ 9. $\cos x (\sin x + \cos x)$

11. $(\sin x + \cos x)(\sin x - \cos x)$

13. $(2 \cos x + 3)(\cos x - 1)$

15. $(\sin x + 3)(\sin^2 x - 3 \sin x + 9)$ 17. $\tan x$

19. $\sin x + 1$ 21. $\frac{2 \tan t + 1}{3 \tan t + 1}$ 23. 1

25. $\frac{5 \cot \phi}{\sin \phi + \cos \phi}$ 27. $\frac{1 + 2 \sin s + 2 \cos s}{\sin^2 s - \cos^2 s}$

29. $\frac{5(\sin \theta - 3)}{3}$ 31. $\sin x \cos x$

33. $\sqrt{\cos \alpha}(\sin \alpha - \cos \alpha)$ 35. $1 - \sin y$

37. $\frac{\sqrt{\sin x \cos x}}{\cos x}$ 39. $\frac{\sqrt{2} \cot y}{2}$ 41. $\frac{\cos x}{\sqrt{\sin x \cos x}}$

43. $\frac{1 + \sin y}{\cos y}$ 45. $\cos \theta = \frac{\sqrt{a^2 - x^2}}{a}$, $\tan \theta = \frac{x}{\sqrt{a^2 - x^2}}$

47. $\sin \theta = \frac{\sqrt{x^2 - 9}}{x}$, $\cos \theta = \frac{3}{x}$ 49. $\sin \theta \tan \theta$

51. $\frac{\sqrt{6} - \sqrt{2}}{4}$ 53. $\frac{\sqrt{3} + 1}{1 - \sqrt{3}}$, or $-2 - \sqrt{3}$

55. $\frac{\sqrt{6} + \sqrt{2}}{4}$ 57. $\sin 59^\circ \approx 0.8572$

59. $\cos 24^\circ \approx 0.9135$ 61. $\tan 52^\circ \approx 1.2799$

63. $\tan(\mu + \nu) = \frac{\sin(\mu + \nu)}{\cos(\mu + \nu)}$
 $= \frac{\sin \mu \cos \nu + \cos \mu \sin \nu}{\cos \mu \cos \nu - \sin \mu \sin \nu}$
 $= \frac{\sin \mu \cos \nu + \cos \mu \sin \nu}{\cos \mu \cos \nu} \cdot \frac{1}{\frac{1}{\cos \mu \cos \nu}}$
 $= \frac{\frac{\sin \mu}{\cos \mu} + \frac{\sin \nu}{\cos \nu}}{1 - \frac{\sin \mu \sin \nu}{\cos \mu \cos \nu}} = \frac{\tan \mu + \tan \nu}{1 - \tan \mu \tan \nu}$

65. 0 67. $-\frac{7}{25}$ 69. -1.5789 71. 0.7071

73. $2 \sin \alpha \cos \beta$ 75. $\cos u$ 77. [1.5] All real numbers

78. [1.5] No solution 79. [6.1] 1.9417 80. [6.1] 1.6645

81. 0° ; the lines are parallel 83. $\frac{3\pi}{4}$, or 135° 85. 4.57°

87. $\frac{\cos(x + h) - \cos x}{h}$
 $= \frac{\cos x \cos h - \sin x \sin h - \cos x}{h}$
 $= \frac{\cos x \cos h - \cos x}{h} - \frac{\sin x \sin h}{h}$
 $= \cos x \left(\frac{\cos h - 1}{h} \right) - \sin x \left(\frac{\sin h}{h} \right)$

89. Let $x = \frac{\pi}{5}$. Then $\frac{\sin 5x}{x} = \frac{\sin \pi}{\pi/5} = 0 \neq \sin 5$. Answers

may vary. 91. Let $\alpha = \frac{\pi}{4}$. Then $\cos(2\alpha) = \cos \frac{\pi}{2} = 0$,

but $2 \cos \alpha = 2 \cos \frac{\pi}{4} = \sqrt{2}$. Answers may vary.

93. Let $x = \frac{\pi}{6}$. Then $\frac{\cos 6x}{\cos x} = \frac{\cos \pi}{\cos \frac{\pi}{6}} = \frac{-1}{\sqrt{3}/2} \neq 6$. Answers

may vary. 95. $\frac{6 - 3\sqrt{3}}{9 + 2\sqrt{3}} \approx 0.0645$ 97. 168.7°

99. $\cos 2\theta = \cos^2 \theta - \sin^2 \theta$, or $1 - 2 \sin^2 \theta$, or $2 \cos^2 \theta - 1$

101. $\tan \left(x + \frac{\pi}{4} \right) = \frac{\tan x + \tan \frac{\pi}{4}}{1 - \tan x \tan \frac{\pi}{4}} = \frac{1 + \tan x}{1 - \tan x}$

103. $\sin(\alpha + \beta) + \sin(\alpha - \beta) = \sin \alpha \cos \beta + \cos \alpha \sin \beta + \sin \alpha \cos \beta - \cos \alpha \sin \beta = 2 \sin \alpha \cos \beta$

Exercise Set 7.2

1. (a) $\tan \frac{3\pi}{10} \approx 1.3763$, $\csc \frac{3\pi}{10} \approx 1.2361$, $\sec \frac{3\pi}{10} \approx 1.7013$,

$\cot \frac{3\pi}{10} \approx 0.7266$; (b) $\sin \frac{\pi}{5} \approx 0.5878$, $\cos \frac{\pi}{5} \approx 0.8090$,

$\tan \frac{\pi}{5} \approx 0.7266$, $\csc \frac{\pi}{5} \approx 1.7013$, $\sec \frac{\pi}{5} \approx 1.2361$,

$\cot \frac{\pi}{5} \approx 1.3763$ 3. (a) $\cos \theta = -\frac{2\sqrt{2}}{3}$, $\tan \theta = -\frac{\sqrt{2}}{4}$,

$\csc \theta = 3$, $\sec \theta = -\frac{3\sqrt{2}}{4}$, $\cot \theta = -2\sqrt{2}$;

(b) $\sin \left(\frac{\pi}{2} - \theta \right) = -\frac{2\sqrt{2}}{3}$, $\cos \left(\frac{\pi}{2} - \theta \right) = \frac{1}{3}$,

$\tan \left(\frac{\pi}{2} - \theta \right) = -2\sqrt{2}$, $\csc \left(\frac{\pi}{2} - \theta \right) = -\frac{3\sqrt{2}}{4}$,

$\sec \left(\frac{\pi}{2} - \theta \right) = 3$, $\cot \left(\frac{\pi}{2} - \theta \right) = -\frac{\sqrt{2}}{4}$;

(c) $\sin \left(\theta - \frac{\pi}{2} \right) = \frac{2\sqrt{2}}{3}$, $\cos \left(\theta - \frac{\pi}{2} \right) = \frac{1}{3}$,

$\tan \left(\theta - \frac{\pi}{2} \right) = 2\sqrt{2}$, $\csc \left(\theta - \frac{\pi}{2} \right) = \frac{3\sqrt{2}}{4}$,

$\sec \left(\theta - \frac{\pi}{2} \right) = 3$, $\cot \left(\theta - \frac{\pi}{2} \right) = \frac{\sqrt{2}}{4}$

5. $\sec \left(x + \frac{\pi}{2} \right) = -\csc x$ 7. $\tan \left(x - \frac{\pi}{2} \right) = -\cot x$

9. $\sin 2\theta = \frac{24}{25}$, $\cos 2\theta = -\frac{7}{25}$, $\tan 2\theta = -\frac{24}{7}$; II

11. $\sin 2\theta = \frac{24}{25}$, $\cos 2\theta = -\frac{7}{25}$, $\tan 2\theta = -\frac{24}{7}$; II

13. $\sin 2\theta = -\frac{120}{169}$, $\cos 2\theta = \frac{119}{169}$, $\tan 2\theta = -\frac{120}{119}$; IV

15. $\cos 4x = 1 - 8 \sin^2 x \cos^2 x$, or

$\cos^4 x - 6 \sin^2 x \cos^2 x + \sin^4 x$, or $8 \cos^4 x - 8 \cos^2 x + 1$

17. $\frac{\sqrt{2 + \sqrt{3}}}{2}$ 19. $\frac{\sqrt{2 + \sqrt{2}}}{2}$ 21. $2 + \sqrt{3}$

23. 0.6421 25. 0.1735 27. $\cos x$ 29. 1 31. $\cos 2x$

33. 8 35. [7.1] $\sin^2 x$ 36. [7.1] 1 37. [7.1] $-\cos^2 x$

38. [7.1] $\csc^2 x$ 39. [7.1] 1 40. [7.1] $\sec^2 x$

41. [7.1] $\cos^2 x$ 42. [7.1] $\tan^2 x$ 43. [6.5] (a), (e)

44. [6.5] (b), (c), (f) 45. [6.5] (d) 46. [6.5] (e)

47. $\sin 141^\circ \approx 0.6293$, $\cos 141^\circ \approx -0.7772$,

$\tan 141^\circ \approx -0.8097$, $\csc 141^\circ \approx 1.5891$, $\sec 141^\circ \approx -1.2867$,

$\cot 141^\circ \approx -1.2350$ 49. $-\cos x(1 + \cot x)$ 51. $\cot^2 y$

53. $\sin \theta = -\frac{15}{17}$, $\cos \theta = -\frac{8}{17}$, $\tan \theta = \frac{15}{8}$

55. (a) 9.80359 m/sec²; (b) 9.80180 m/sec²;

(c) $g = 9.78049(1 + 0.005264 \sin^2 \phi + 0.000024 \sin^4 \phi)$

Exercise Set 7.3

1.

$$\frac{\sec x - \sin x \tan x}{\cos x} - \sin x \cdot \frac{\sin x}{\cos x} = \frac{1 - \sin^2 x}{\cos x} - \frac{\cos^2 x}{\cos x} = \frac{\cos^2 x}{\cos x} - \frac{\cos^2 x}{\cos x} = 0$$

3.

$$\frac{1 - \cos x}{\sin x} \cdot \frac{\sin x}{1 + \cos x} = \frac{\sin x}{1 + \cos x} \cdot \frac{1 - \cos x}{\sin x (1 - \cos x)} = \frac{1 - \cos^2 x}{\sin x (1 - \cos x)} = \frac{\sin^2 x}{\sin x (1 - \cos x)} = \frac{1 - \cos x}{1 - \cos x} = 1$$

5.

$$\frac{1 + \tan \theta}{1 - \tan \theta} + \frac{1 + \cot \theta}{1 - \cot \theta} = \frac{1 + \frac{\sin \theta}{\cos \theta}}{1 - \frac{\sin \theta}{\cos \theta}} + \frac{1 + \frac{\cos \theta}{\sin \theta}}{1 - \frac{\cos \theta}{\sin \theta}} = \frac{\cos \theta + \sin \theta}{\cos \theta - \sin \theta} + \frac{\sin \theta + \cos \theta}{\sin \theta - \cos \theta} = \frac{\cos \theta + \sin \theta}{\cos \theta - \sin \theta} - \frac{\sin \theta + \cos \theta}{\cos \theta - \sin \theta} = \frac{\cos \theta + \sin \theta - \sin \theta - \cos \theta}{\cos \theta - \sin \theta} = \frac{0}{\cos \theta - \sin \theta} = 0$$

7.

$$\frac{\cos^2 \alpha + \cot \alpha}{\cos^2 \alpha - \cot \alpha} = \frac{\cos^2 \alpha \tan \alpha + 1}{\cos^2 \alpha \tan \alpha - 1} = \frac{\cos^2 \alpha \frac{\sin \alpha}{\cos \alpha} + 1}{\cos^2 \alpha \frac{\sin \alpha}{\cos \alpha} - 1} = \frac{\cos \alpha \left(\cos \alpha + \frac{1}{\sin \alpha} \right)}{\cos \alpha \left(\cos \alpha - \frac{1}{\sin \alpha} \right)} = \frac{\cos \alpha + \frac{1}{\sin \alpha}}{\cos \alpha - \frac{1}{\sin \alpha}} = \frac{\sin \alpha \cos \alpha + 1}{\sin \alpha \cos \alpha - 1}$$

9.

$$\frac{2 \tan \theta}{1 + \tan^2 \theta} = \frac{2 \tan \theta}{\sec^2 \theta} = \frac{2 \sin \theta}{\cos \theta} \cdot \frac{\cos^2 \theta}{1} = 2 \sin \theta \cos \theta$$

11.

$$\frac{1 - \cos 5\theta \cos 3\theta - \sin 5\theta \sin 3\theta}{1 - [\cos 5\theta \cos 3\theta + \sin 5\theta \sin 3\theta]} = \frac{2 \sin^2 \theta}{1 - \cos(5\theta - 3\theta)} = \frac{2 \sin^2 \theta}{1 - \cos 2\theta}$$

13.

$$\frac{2 \sin \theta \cos^3 \theta + 2 \sin^3 \theta \cos \theta}{2 \sin \theta \cos \theta (\cos^2 \theta + \sin^2 \theta)} = \frac{\sin^2 \theta}{2 \sin \theta \cos \theta} = \frac{\sin \theta}{2 \cos \theta}$$

15.

$$\frac{\tan x - \sin x}{2 \tan x} = \frac{\frac{\sin x}{\cos x} - \sin x}{\frac{2 \sin x}{\cos x}} = \frac{1 - \cos x}{2}$$

17.

$$\frac{\sin(\alpha + \beta) \sin(\alpha - \beta)}{(\sin \alpha \cos \beta + \cos \alpha \sin \beta)(\sin \alpha \cos \beta - \cos \alpha \sin \beta)} = \frac{\sin^2 \alpha - \sin^2 \beta}{1 - \cos^2 \alpha - (1 - \cos^2 \beta)} = \frac{\sin^2 \alpha - \sin^2 \beta}{\cos^2 \beta - \cos^2 \alpha} = \frac{\cos^2 \beta (1 - \cos^2 \alpha) - \cos^2 \alpha (1 - \cos^2 \beta)}{\cos^2 \beta - \cos^2 \alpha} = \frac{\cos^2 \beta - \cos^2 \alpha \cos^2 \beta - \cos^2 \alpha + \cos^2 \alpha \cos^2 \beta}{\cos^2 \beta - \cos^2 \alpha} = 1$$

19.

$$\frac{\tan \theta (\tan \theta + \cot \theta)}{\tan^2 \theta + \tan \theta \cot \theta} = \frac{\tan^2 \theta + 1}{\tan^2 \theta + 1} = \sec^2 \theta$$

21.

$$\frac{1 + \cos^2 x}{\sin^2 x} = \frac{1}{\sin^2 x} + \frac{\cos^2 x}{\sin^2 x} = \csc^2 x + \cot^2 x = \csc^2 x + \csc^2 x - 1 = 2 \csc^2 x - 1$$

$$23. \frac{\frac{1 + \sin x}{1 - \sin x} + \frac{\sin x - 1}{1 + \sin x}}{(1 + \sin x)^2 - (1 - \sin x)^2} \cdot \frac{1 - \sin^2 x}{\cos^2 x} = \frac{4 \sec x \tan x}{\cos^2 x} = 4 \cdot \frac{1}{\cos x} \cdot \frac{\sin x}{\cos x} = \frac{4 \sin x}{\cos^2 x}$$

$$25. \frac{\cos^2 \alpha \cot^2 \alpha}{(1 - \sin^2 \alpha) \cot^2 \alpha} = \frac{\cot^2 \alpha - \cos^2 \alpha}{\cot^2 \alpha - \sin^2 \alpha \cdot \frac{\cos^2 \alpha}{\sin^2 \alpha}} = \frac{\cot^2 \alpha - \cos^2 \alpha}{\cot^2 \alpha - \cos^2 \alpha}$$

$$27. \frac{2 \sin^2 \theta \cos^2 \theta + \cos^4 \theta}{\cos^2 \theta (2 \sin^2 \theta + \cos^2 \theta)} = \frac{1 - \sin^4 \theta}{(1 + \sin^2 \theta)(1 - \sin^2 \theta)} = \frac{\cos^2 \theta (\sin^2 \theta + \sin^2 \theta + \cos^2 \theta)}{\cos^2 \theta (\sin^2 \theta + 1)(\cos^2 \theta)} = \frac{\cos^2 \theta (\sin^2 \theta + 1)}{\cos^2 \theta (\sin^2 \theta + 1)(\cos^2 \theta)} = \frac{1}{\cos^2 \theta}$$

$$29. \frac{\frac{1 + \sin x}{1 - \sin x} \cdot \frac{1 + \sin x}{1 + \sin x}}{(1 + \sin x)^2} = \frac{(\sec x + \tan x)^2}{(1 + \sin x)^2} = \frac{\left(\frac{1}{\cos x} + \frac{\sin x}{\cos x}\right)^2}{(1 + \sin x)^2} = \frac{1 + \sin x}{\cos^2 x}$$

31. Sine sum and difference identities:

$$\sin(x + y) = \sin x \cos y + \cos x \sin y,$$

$$\sin(x - y) = \sin x \cos y - \cos x \sin y.$$

Add the sum and difference identities:

$$\sin(x + y) + \sin(x - y) = 2 \sin x \cos y$$

$$\frac{1}{2}[\sin(x + y) + \sin(x - y)] = \sin x \cos y. \quad (3)$$

Subtract the difference identity from the sum identity:

$$\sin(x + y) - \sin(x - y) = 2 \cos x \sin y$$

$$\frac{1}{2}[\sin(x + y) - \sin(x - y)] = \cos x \sin y. \quad (4)$$

$$33. \sin 3\theta - \sin 5\theta = 2 \cos \frac{8\theta}{2} \sin \frac{-2\theta}{2} = -2 \cos 4\theta \sin \theta$$

$$35. \sin 8\theta + \sin 5\theta = 2 \sin \frac{13\theta}{2} \cos \frac{3\theta}{2}$$

$$37. \sin 7u \sin 5u = \frac{1}{2}(\cos 2u - \cos 12u)$$

$$39. 7 \cos \theta \sin 7\theta = \frac{7}{2}[\sin 8\theta - \sin(-6\theta)] = \frac{7}{2}(\sin 8\theta + \sin 6\theta)$$

$$41. \cos 55^\circ \sin 25^\circ = \frac{1}{2}(\sin 80^\circ - \sin 30^\circ) = \frac{1}{2} \sin 80^\circ - \frac{1}{4}$$

$$43. \frac{\sin 4\theta + \sin 6\theta}{2 \sin \frac{10\theta}{2} \cos \frac{-2\theta}{2}} = \frac{\cot \theta (\cos 4\theta - \cos 6\theta)}{\sin \theta \left(2 \sin \frac{10\theta}{2} \sin \frac{2\theta}{2}\right)} = \frac{2 \sin 5\theta \cos(-\theta)}{2 \sin 5\theta \cos \theta} = \frac{\cos \theta}{\sin \theta} (2 \sin 5\theta \sin \theta) = 2 \sin 5\theta \cos \theta$$

$$45. \frac{\cot 4x (\sin x + \sin 4x + \sin 7x)}{\cos 4x \left(\sin 4x + 2 \sin \frac{8x}{2} \cos \frac{-6x}{2}\right)} = \frac{\cos x + \cos 4x + \cos 7x}{\cos 4x + 2 \cos \frac{8x}{2} \cdot \cos \frac{6x}{2}} = \frac{\cos 4x}{\sin 4x} (\sin 4x + 2 \sin 4x \cos 3x) = \frac{\cos 4x (1 + 2 \cos 3x)}{\cos 4x (1 + 2 \cos 3x)}$$

$$47. \frac{\cot \frac{x+y}{2}}{\cos \frac{x+y}{2}} = \frac{\sin y - \sin x}{\cos x - \cos y} = \frac{2 \cos \frac{x+y}{2} \sin \frac{y-x}{2}}{2 \sin \frac{x+y}{2} \sin \frac{y-x}{2}} = \frac{\cos \frac{x+y}{2}}{\sin \frac{x+y}{2}}$$

$$49. \frac{\tan \frac{\theta + \phi}{2} (\sin \theta - \sin \phi)}{\frac{\sin \frac{\theta + \phi}{2}}{\cos \frac{\theta + \phi}{2}}} = \frac{\tan \frac{\theta - \phi}{2} (\sin \theta + \sin \phi)}{\frac{\sin \frac{\theta - \phi}{2}}{\cos \frac{\theta - \phi}{2}}} = \frac{2 \cos \frac{\theta + \phi}{2} \sin \frac{\theta - \phi}{2}}{2 \sin \frac{\theta + \phi}{2} \cdot \sin \frac{\theta - \phi}{2}} = \frac{\cos \frac{\theta + \phi}{2}}{\sin \frac{\theta + \phi}{2}}$$

51. [5.1] (a), (d)

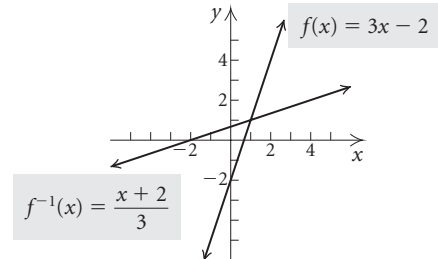

(b) yes; (c) $f^{-1}(x) = \frac{x + 2}{3}$

52. [5.1] (a), (d)

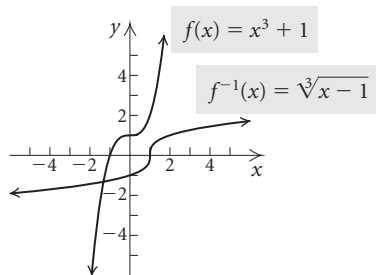

(b) yes; (c) $f^{-1}(x) = \sqrt[3]{x-1}$

53. [5.1] (a), (d)

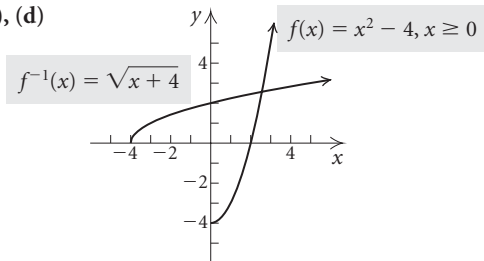

(b) yes; (c) $f^{-1}(x) = \sqrt{x+4}$

54. [5.1] (a), (d)

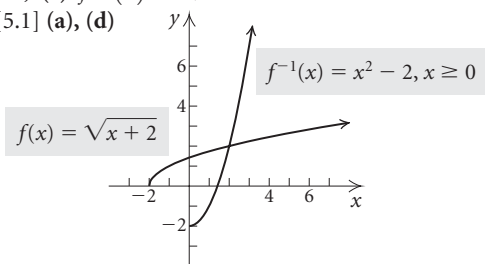

(b) yes; (c) $f^{-1}(x) = x^2 - 2, x \geq 0$

55. [3.2] $0, \frac{5}{2}$ 56. [3.2] $-4, \frac{7}{3}$ 57. [3.2] $\pm 2, \pm 3i$

58. [3.2] $5 \pm 2\sqrt{6}$ 59. [3.4] 27 60. [3.4] 9

61.

$$\begin{array}{l|l} \ln |\tan x| & -\ln |\cot x| \\ \ln \left| \frac{1}{\cot x} \right| & \\ \ln |1| - \ln |\cot x| & \\ 0 - \ln |\cot x| & \\ -\ln |\cot x| & \end{array}$$

63. $\log(\cos x - \sin x) + \log(\cos x + \sin x)$
 $= \log[(\cos x - \sin x)(\cos x + \sin x)]$
 $= \log(\cos^2 x - \sin^2 x) = \log \cos 2x$

65. $\frac{1}{\omega C(\tan \theta + \tan \phi)} = \frac{1}{\omega C\left(\frac{\sin \theta}{\cos \theta} + \frac{\sin \phi}{\cos \phi}\right)}$
 $= \frac{1}{\omega C\left(\frac{\sin \theta \cos \phi + \sin \phi \cos \theta}{\cos \theta \cos \phi}\right)}$
 $= \frac{\cos \theta \cos \phi}{\omega C \sin(\theta + \phi)}$

Mid-Chapter Mixed Review: Chapter 7

1. True 2. False 3. True 4. True 5. J 6. H
 7. D 8. I 9. C 10. E 11. A 12. G 13. F

14. B 15. $\frac{\sqrt{\cos x}}{\sin x}$ 16. 1 17. $2 \cos x + 1$

18. $-\cos x$ 19. $1 - \sin 2x$ 20. $\cos x$ 21. $\frac{\sqrt{\sec x + 1}}{\sin x}$

22. $\cos 12^\circ \approx 0.9781$ 23. $\frac{\sqrt{2 - \sqrt{2}}}{2}$ 24. $\frac{\sqrt{6 + \sqrt{2}}}{4}$

25. $-\frac{119}{120}$ 26. $-\frac{24}{25}$; quadrant IV

27.
$$\frac{\cos^2 x}{2} \cdot \frac{\tan x + \sin x}{2 \tan x} = \frac{1 + \cos x}{2} \cdot \frac{1}{2} \left[\frac{\frac{\sin x}{\cos x} + \sin x}{\frac{\sin x}{\cos x}} \right]$$

$$= \frac{1 + \cos x}{2} \cdot \frac{1}{2} \frac{\sin x + \sin x \cos x}{\cos x} \cdot \frac{\cos x}{\sin x}$$

$$= \frac{1 + \cos x}{2} \cdot \frac{1}{2} \frac{\sin x(1 + \cos x)}{\sin x}$$

$$= \frac{1 + \cos x}{2}$$

28.
$$\frac{1 - \sin x}{\cos x} \cdot \frac{1 + \sin x}{1 + \sin x} = \frac{1 - \sin^2 x}{\cos x(1 + \sin x)}$$

$$= \frac{\cos^2 x}{\cos x(1 + \sin x)} = \frac{\cos x}{1 + \sin x}$$

29.

$$\frac{\frac{\sin^3 x - \cos^3 x}{\sin x - \cos x}}{(\sin x - \cos x)(\sin^2 x + \sin x \cos x + \cos^2 x)} = \frac{\frac{2 + \sin 2x}{2}}{2 + 2 \sin x \cos x}$$

$$= \frac{\frac{2 + \sin 2x}{2}}{2(1 + \sin x \cos x)} = \frac{2 + \sin 2x}{2(1 + \sin x \cos x)}$$

30.

$$\frac{\sin 6\theta - \sin 2\theta}{2 \cos \frac{8\theta}{2} \sin \frac{4\theta}{2}} = \frac{\tan 2\theta (\cos 2\theta + \cos 6\theta)}{\cos 2\theta \left(2 \cos \frac{8\theta}{2} \cos \frac{4\theta}{2}\right)}$$

$$= \frac{\sin 2\theta}{\cos 2\theta} (2 \cos 4\theta \cos 2\theta) = 2 \cos 4\theta \sin 2\theta$$

31. The expression $\tan(x + 450^\circ)$ can be simplified using the sine and cosine sum formulas but cannot be simplified using the tangent sum formula because although $\sin 450^\circ$ and $\cos 450^\circ$ are both defined, $\tan 450^\circ$ is undefined. 32. Each has amplitude 1 and is periodic. The period of $y_1 = \sin x$ is 2π , of $y_2 = \sin 2x$ is π , and of $y_3 = \sin(x/2)$ is 4π . 33. (a) $x \neq k\pi/2$, k odd; the tangent function is not defined for these values of x ; (b) $\sin x = 0$ for $x = k\pi$, k an integer; $\cos x = -1$ for $x = k\pi$, k an odd integer; thus the restriction $x \neq k\pi$, k an integer applies. 34. In the first line, $\cos 4x \neq 2 \cos 2x$. In the second line, $\cos 2x \neq \cos^2 x + \sin^2 x$. If the second line had been correct, the third line would have been correct as well.

Exercise Set 7.4

1. $-\frac{\pi}{3}, -60^\circ$ 3. $\frac{\pi}{4}, 45^\circ$ 5. $\frac{\pi}{4}, 45^\circ$ 7. $0, 0^\circ$
 9. $\frac{\pi}{6}, 30^\circ$ 11. $\frac{\pi}{6}, 30^\circ$ 13. $\frac{5\pi}{6}, 150^\circ$ 15. $-\frac{\pi}{6}, -30^\circ$
 17. $\frac{\pi}{2}, 90^\circ$ 19. $\frac{\pi}{3}, 60^\circ$ 21. $0.3520, 20.2^\circ$ 23. $1.2917, 74.0^\circ$
 25. $2.9463, 168.8^\circ$ 27. $-0.1600, -9.2^\circ$
 29. $0.8289, 47.5^\circ$ 31. $-0.9600, -55.0^\circ$
 33. $\sin^{-1}: [-1, 1]; \cos^{-1}: [-1, 1]; \tan^{-1}: (-\infty, \infty)$
 35. $\theta = \sin^{-1}\left(\frac{2000}{d}\right)$ 37. 0.3 39. $\frac{\pi}{4}$ 41. $\frac{\pi}{5}$
 43. $-\frac{\pi}{3}$ 45. $\frac{1}{2}$ 47. 1 49. $\frac{\pi}{3}$ 51. $\frac{\sqrt{11}}{33}$ 53. $-\frac{\pi}{6}$
 55. $\frac{a}{\sqrt{a^2 + 9}}$ 57. $\frac{\sqrt{q^2 - p^2}}{p}$ 59. $\frac{p}{3}$ 61. $\frac{\sqrt{3}}{2}$
 63. $-\frac{\sqrt{2}}{10}$ 65. $xy + \sqrt{(1-x^2)(1-y^2)}$ 67. 0.9861
 69. [6.5] Periodic 70. [6.4] Radian measure
 71. [6.1] Similar 72. [6.2] Angle of depression
 73. [6.4] Angular speed 74. [6.3] Supplementary
 75. [6.5] Amplitude 76. [6.5] Circular
 77.

$\sin^{-1} x + \cos^{-1} x$	$\frac{\pi}{2}$
$\sin(\sin^{-1} x + \cos^{-1} x)$	$\sin \frac{\pi}{2}$
$[\sin(\sin^{-1} x)][\cos(\cos^{-1} x)] +$ $[\cos(\sin^{-1} x)][\sin(\cos^{-1} x)]$	1
$x \cdot x + \sqrt{1-x^2} \cdot \sqrt{1-x^2}$ $x^2 + 1 - x^2$	1

79.

$\sin^{-1} x$	$\tan^{-1} \frac{x}{\sqrt{1-x^2}}$
$\sin(\sin^{-1} x)$	$\sin\left(\tan^{-1} \frac{x}{\sqrt{1-x^2}}\right)$
x	x

81.

$\sin^{-1} x$	$\cos^{-1} \sqrt{1-x^2}$
$\sin(\sin^{-1} x)$	$\sin(\cos^{-1} \sqrt{1-x^2})$
x	x

83. $\theta = \tan^{-1} \frac{y+h}{x} - \tan^{-1} \frac{y}{x}; 38.7^\circ$

Visualizing the Graph

1. D 2. G 3. C 4. H 5. I 6. A 7. E
 8. J 9. F 10. B

Exercise Set 7.5

1. $\frac{\pi}{6} + 2k\pi, \frac{11\pi}{6} + 2k\pi$, or $30^\circ + k \cdot 360^\circ, 330^\circ + k \cdot 360^\circ$
 3. $\frac{2\pi}{3} + k\pi$, or $120^\circ + k \cdot 180^\circ$ 5. $\frac{\pi}{6} + 2k\pi, \frac{5\pi}{6} + 2k\pi$, or
 $30^\circ + k \cdot 360^\circ, 150^\circ + k \cdot 360^\circ$ 7. $\frac{3\pi}{4} + 2k\pi, \frac{5\pi}{4} + 2k\pi$,
 or $135^\circ + k \cdot 360^\circ, 225^\circ + k \cdot 360^\circ$ 9. $1.7120, 4.5712$, or
 $98.09^\circ, 261.91^\circ$ 11. $\frac{4\pi}{3}, \frac{5\pi}{3}$, or $240^\circ, 300^\circ$ 13. $\frac{\pi}{4}, \frac{3\pi}{4},$
 $\frac{5\pi}{4}, \frac{7\pi}{4}$, or $45^\circ, 135^\circ, 225^\circ, 315^\circ$ 15. $\frac{\pi}{6}, \frac{5\pi}{6}, \frac{3\pi}{2}$, or
 $30^\circ, 150^\circ, 270^\circ$ 17. $\frac{\pi}{6}, \frac{\pi}{2}, \frac{3\pi}{2}, \frac{11\pi}{6}$, or $30^\circ, 90^\circ, 270^\circ, 330^\circ$
 19. $1.9106, \frac{2\pi}{3}, \frac{4\pi}{3}, 4.3726$, or $109.47^\circ, 120^\circ, 240^\circ, 250.53^\circ$
 21. $0, \frac{\pi}{4}, \frac{3\pi}{4}, \pi, \frac{5\pi}{4}, \frac{7\pi}{4}$, or $0^\circ, 45^\circ, 135^\circ, 180^\circ, 225^\circ, 315^\circ$
 23. $2.4402, 3.8430$, or $139.81^\circ, 220.19^\circ$ 25. $0.6496, 2.9557,$
 $3.7912, 6.0973$, or $37.22^\circ, 169.35^\circ, 217.22^\circ, 349.35^\circ$
 27. $0, \pi, \frac{7\pi}{6}, \frac{11\pi}{6}$ 29. $0, \pi$ 31. $0, \pi$ 33. $\frac{3\pi}{4}, \frac{7\pi}{4}$
 35. $\frac{2\pi}{3}, \frac{4\pi}{3}, \frac{3\pi}{2}$ 37. $\frac{\pi}{4}, \frac{3\pi}{4}, \frac{5\pi}{4}, \frac{7\pi}{4}$ 39. $\frac{\pi}{12}, \frac{5\pi}{12}$
 41. $0.967, 1.853, 4.108, 4.994$ 43. $\frac{2\pi}{3}, \frac{4\pi}{3}$
 45. (a) April 5th: 14.5 hr; August 18th: 16.6 hr; November 29th: 5.1 hr; (b) 75th day (March 16th) and 268th day (September 25th) 47. [6.2] $B = 35^\circ, b \approx 140.7, c \approx 245.4$
 48. [6.2] $R \approx 15.5^\circ, T \approx 74.5^\circ, t \approx 13.7$ 49. [1.5] 36
 50. [1.5] 14 51. $\frac{\pi}{3}, \frac{2\pi}{3}, \frac{4\pi}{3}, \frac{5\pi}{3}$ 53. $\frac{\pi}{3}, \frac{4\pi}{3}$ 55. 0
 57. $e^{3\pi/2 + 2k\pi}$, where k (an integer) ≤ -1 59. 1.24 days,
 6.76 days 61. 16.5°N 63. 1 65. $\frac{5}{26}$, or about 0.1923

Review Exercises: Chapter 7

1. True 2. True 3. True 4. False 5. False
 6. $\csc^2 x$ 7. 1 8. $\tan^2 y - \cot^2 y$ 9. $\frac{(\cos^2 x + 1)^2}{\cos^2 x}$
 10. $\csc x (\sec x - \csc x)$ 11. $(3 \sin y + 5)(\sin y - 4)$

12. $(10 - \cos u)(100 + 10 \cos u + \cos^2 u)$ 13. 1
 14. $\frac{1}{2} \sec x$ 15. $\frac{3 \tan x}{\sin x - \cos x}$ 16. $\frac{3 \cos y + 3 \sin y + 2}{\cos^2 y - \sin^2 y}$
 17. 1 18. $\frac{1}{4} \cot x$ 19. $\sin x + \cos x$ 20. $\frac{\cos x}{1 - \sin x}$
 21. $\frac{\cos x}{\sqrt{\sin x}}$ 22. $3 \sec \theta$ 23. $\cos x \cos \frac{3\pi}{2} - \sin x \sin \frac{3\pi}{2}$
 24. $\frac{\tan 45^\circ - \tan 30^\circ}{1 + \tan 45^\circ \tan 30^\circ}$ 25. $\cos(27^\circ - 16^\circ)$, or $\cos 11^\circ$
 26. $\frac{-\sqrt{6} - \sqrt{2}}{4}$ 27. $2 - \sqrt{3}$ 28. -0.3745

29. $-\sin x$ 30. $\sin x$ 31. $-\cos x$
 32. (a) $\sin \alpha = -\frac{4}{5}$, $\tan \alpha = \frac{4}{3}$, $\cot \alpha = \frac{3}{4}$, $\sec \alpha = -\frac{5}{3}$,
 $\csc \alpha = -\frac{5}{4}$; (b) $\sin\left(\frac{\pi}{2} - \alpha\right) = -\frac{3}{5}$, $\cos\left(\frac{\pi}{2} - \alpha\right) = -\frac{4}{5}$,
 $\tan\left(\frac{\pi}{2} - \alpha\right) = \frac{3}{4}$, $\cot\left(\frac{\pi}{2} - \alpha\right) = \frac{4}{3}$,
 $\sec\left(\frac{\pi}{2} - \alpha\right) = -\frac{5}{4}$, $\csc\left(\frac{\pi}{2} - \alpha\right) = -\frac{5}{3}$;
 (c) $\sin\left(\alpha + \frac{\pi}{2}\right) = -\frac{3}{5}$, $\cos\left(\alpha + \frac{\pi}{2}\right) = \frac{4}{5}$,
 $\tan\left(\alpha + \frac{\pi}{2}\right) = -\frac{3}{4}$, $\cot\left(\alpha + \frac{\pi}{2}\right) = -\frac{4}{3}$,
 $\sec\left(\alpha + \frac{\pi}{2}\right) = \frac{5}{4}$, $\csc\left(\alpha + \frac{\pi}{2}\right) = -\frac{5}{3}$ 33. $-\sec x$
 34. $\tan 2\theta = \frac{24}{7}$, $\cos 2\theta = \frac{7}{25}$, $\sin 2\theta = \frac{24}{25}$; I

35. $\frac{\sqrt{2} - \sqrt{2}}{2}$ 36. $\sin 2\beta = 0.4261$, $\cos \frac{\beta}{2} = 0.9940$,
 $\cos 4\beta = 0.6369$ 37. $\cos x$ 38. 1 39. $\sin 2x$

40. $\tan 2x$

41.

$\frac{1 - \sin x}{\cos x}$	$\frac{\cos x}{1 + \sin x}$
$\frac{1 - \sin x}{\cos x} \cdot \frac{\cos x}{\cos x}$	$\frac{1 + \sin x}{\cos x} \cdot \frac{1 - \sin x}{1 - \sin x}$
$\frac{\cos x - \sin x \cos x}{\cos^2 x}$	$\frac{1 - \sin^2 x}{\cos x - \sin x \cos x}$
	$\frac{1 - \sin^2 x}{\cos^2 x}$

42.

$\frac{1 + \cos 2\theta}{\sin 2\theta}$	$\cot \theta$
$\frac{1 + 2 \cos^2 \theta - 1}{2 \sin \theta \cos \theta}$	$\frac{\cos \theta}{\sin \theta}$
$\frac{\cos \theta}{\sin \theta}$	

43.

$\frac{\tan y + \sin y}{2 \tan y}$	$\cos^2 \frac{y}{2}$
$\frac{1}{2} \left[\frac{\sin y + \sin y \cos y}{\cos y} \right]$	$\frac{1 + \cos y}{2}$
$\frac{1}{2} \left[\frac{\sin y (1 + \cos y) \cdot \cos y}{\cos y \sin y} \right]$	
$\frac{1 + \cos y}{2}$	

44.

$\frac{\sin x - \cos x}{\cos^2 x}$	$\frac{\tan^2 x - 1}{\sin x + \cos x}$
	$\frac{\frac{\sin^2 x}{\cos^2 x} - 1}{\sin x + \cos x}$
	$\frac{\sin x + \cos x}{\sin^2 x - \cos^2 x} \cdot \frac{1}{\sin x + \cos x}$
	$\frac{\sin x - \cos x}{\cos^2 x}$

45. $3 \cos 2\theta \sin \theta = \frac{3}{2}(\sin 3\theta - \sin \theta)$
 46. $\sin \theta - \sin 4\theta = -2 \cos \frac{5\theta}{2} \sin \frac{3\theta}{2}$ 47. $-\frac{\pi}{6}, -30^\circ$
 48. $\frac{\pi}{6}, 30^\circ$ 49. $\frac{\pi}{4}, 45^\circ$ 50. $0, 0^\circ$ 51. 1.7920, 102.7°
 52. 0.3976, 22.8° 53. $\frac{1}{2}$ 54. $\frac{\sqrt{3}}{3}$ 55. $\frac{\pi}{7}$ 56. $\frac{\sqrt{2}}{2}$
 57. $\frac{3}{\sqrt{b^2 + 9}}$ 58. $-\frac{7}{25}$ 59. $\frac{3\pi}{4} + 2k\pi, \frac{5\pi}{4} + 2k\pi$, or
 $135^\circ + k \cdot 360^\circ, 225^\circ + k \cdot 360^\circ$ 60. $\frac{\pi}{3} + k\pi$, or

- $60^\circ + k \cdot 180^\circ$ 61. $\frac{\pi}{6}, \frac{5\pi}{6}, \frac{7\pi}{6}, \frac{11\pi}{6}$ 62. $\frac{\pi}{4}, \frac{\pi}{2}, \frac{3\pi}{4}, \frac{5\pi}{4}$,
 $\frac{3\pi}{2}, \frac{7\pi}{4}$ 63. $\frac{2\pi}{3}, \pi, \frac{4\pi}{3}$ 64. $0, \pi$ 65. $\frac{\pi}{4}, \frac{3\pi}{4}, \frac{5\pi}{4}, \frac{7\pi}{4}$
 66. $0, \frac{\pi}{2}, \pi, \frac{3\pi}{2}$ 67. $\frac{7\pi}{12}, \frac{23\pi}{12}$ 68. 0.864, 2.972, 4.006,
 6.114 69. B 70. A 71. C 72. 108.4°

73. $\cos(u + v) = \cos u \cos v - \sin u \sin v$
 $= \cos u \cos v - \cos\left(\frac{\pi}{2} - u\right) \cos\left(\frac{\pi}{2} - v\right)$
 74. $\cos^2 x$ 75. $\sin \theta = \sqrt{\frac{1}{2} + \frac{\sqrt{6}}{5}}$; $\cos \theta = \sqrt{\frac{1}{2} - \frac{\sqrt{6}}{5}}$;
 $\tan \theta = \sqrt{\frac{5 + 2\sqrt{6}}{5 - 2\sqrt{6}}}$ 76. $\ln e^{\sin t} = \log_e e^{\sin t} = \sin t$

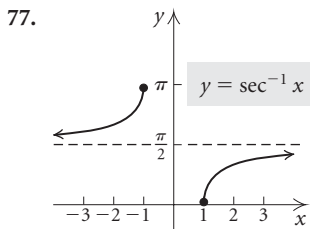

78. Let $x = \frac{\sqrt{2}}{2}$. Then $\tan^{-1} \frac{\sqrt{2}}{2} \approx 0.6155$ and

$$\frac{\sin^{-1} \frac{\sqrt{2}}{2}}{\cos^{-1} \frac{\sqrt{2}}{2}} = \frac{\frac{\pi}{4}}{\frac{3\pi}{4}} = 1. \quad 79. \frac{\pi}{2}, \frac{3\pi}{2}$$

80. The ranges of the inverse trigonometric functions are restricted in order that they might be functions. 81. Yes; first note that $7\pi/6 = \pi/6 + \pi$. Since $\pi/6 + k\pi$ includes both odd and even multiples of π , it is equivalent to $\pi/6 + 2k\pi$ and $7\pi/6 + 2k\pi$. 82. The graphs have different domains and ranges. The graph of $y = \sin^{-1} x$ is the reflection of the portion of the graph of $y = \sin x$ for $-\pi/2 \leq x \leq \pi/2$, across the line $y = x$. 83. A trigonometric equation that is an identity is true for all possible replacements of the variables. A trigonometric equation that is not true for all possible replacements is not an identity. The equation $\sin^2 x + \cos^2 x = 1$ is an identity whereas $\sin^2 x = 1$ is not. 84. The range of the arcsine function does not include $5\pi/6$. It is $[-\pi/2, \pi/2]$.

Test: Chapter 7

1. [7.1] $2 \cos x + 1$ 2. [7.1] 1 3. [7.1] $\frac{\cos \theta}{1 + \sin \theta}$
 4. [7.1] $2 \cos \theta$ 5. [7.1] $\frac{\sqrt{2} + \sqrt{6}}{4}$ 6. [7.1] $\frac{3 - \sqrt{3}}{3 + \sqrt{3}}$
 7. [7.1] $\frac{120}{169}$ 8. [7.2] $\frac{\sqrt{5}}{3}$ 9. [7.2] $\frac{24}{25}, \Pi$
 10. [7.2] $\frac{\sqrt{2} + \sqrt{3}}{2}$ 11. [7.2] 0.9304 12. [7.2] $3 \sin 2x$

13. [7.3]

$\frac{\csc x - \cos x \cot x}{\sin x} - \cos x \cdot \frac{\cos x}{\sin x}$	$\sin x$
$\frac{1 - \cos^2 x}{\sin x}$	
$\frac{\sin^2 x}{\sin x}$	
$\sin x$	

14. [7.3]

$\frac{(\sin x + \cos x)^2}{\sin^2 x + 2 \sin x \cos x + \cos^2 x}$	$1 + \sin 2x$
$\frac{1 + 2 \sin x \cos x}{1 + \sin 2x}$	

15. [7.3]

$(\csc \beta + \cot \beta)^2$	$\frac{1 + \cos \beta}{1 - \cos \beta}$
$\left(\frac{1}{\sin \beta} + \frac{\cos \beta}{\sin \beta}\right)^2$	$\frac{1 + \cos \beta}{1 - \cos \beta} \cdot \frac{1 + \cos \beta}{1 + \cos \beta}$
$\left(\frac{1 + \cos \beta}{\sin \beta}\right)^2$	$\frac{(1 + \cos \beta)^2}{1 - \cos^2 \beta}$
$\frac{(1 + \cos \beta)^2}{\sin^2 \beta}$	$\frac{(1 + \cos \beta)^2}{\sin^2 \beta}$

16. [7.3]

$\frac{1 + \sin \alpha}{1 + \csc \alpha}$	$\frac{\tan \alpha}{\sec \alpha}$
$\frac{1 + \sin \alpha}{1 + \frac{1}{\sin \alpha}}$	$\frac{\sin \alpha}{\cos \alpha}$
$\frac{1 + \sin \alpha}{\sin \alpha + 1}$	$\frac{\cos \alpha}{1}$
$\frac{\sin \alpha}{\sin \alpha}$	$\cos \alpha$

17. [7.4] $\cos 8\alpha - \cos \alpha = -2 \sin \frac{9\alpha}{2} \sin \frac{7\alpha}{2}$
 18. [7.4] $4 \sin \beta \cos 3\beta = 2(\sin 4\beta - \sin 2\beta)$
 19. [7.4] -45° 20. [7.4] $\frac{\pi}{3}$ 21. [7.4] 2.3072
 22. [7.4] $\frac{\sqrt{3}}{2}$ 23. [7.4] $\frac{5}{\sqrt{x^2 - 25}}$ 24. [7.4] 0
 25. [7.5] $\frac{\pi}{6}, \frac{5\pi}{6}, \frac{7\pi}{6}, \frac{11\pi}{6}$ 26. [7.5] $0, \frac{\pi}{4}, \frac{3\pi}{4}, \pi$
 27. [7.5] $\frac{\pi}{2}, \frac{11\pi}{6}$ 28. [7.4] D 29. [7.2] $\sqrt{\frac{11}{12}}$

Chapter 8

Exercise Set 8.1

1. $A = 121^\circ, a \approx 33, c \approx 14$ 3. $B \approx 57.4^\circ, C \approx 86.1^\circ, c \approx 40$, or $B \approx 122.6^\circ, C \approx 20.9^\circ, c \approx 14$ 5. $B \approx 44^\circ 24', A \approx 74^\circ 26', a \approx 33.3$ 7. $A = 110.36^\circ, a \approx 5$ mi, $b \approx 3.4$ mi
 9. $B \approx 83.78^\circ, A \approx 12.44^\circ, a \approx 12.30$ yd 11. $B \approx 14.7^\circ, C \approx 135.0^\circ, c \approx 28.04$ cm 13. No solution
 15. $B = 125.27^\circ, b \approx 302$ m, $c \approx 138$ m 17. 8.2 ft²
 19. 12 yd² 21. 596.98 ft² 23. About 3894 ft 25. 787 ft²
 27. About 51 ft 29. From A: about 35 mi; from B: about 66 mi 31. About 102 mi 33. [6.1] 1.348, 77.2°
 34. [6.1] No angle 35. [6.1] 18.24° 36. [6.1] 125.06°
 37. [R.1] 5 38. [6.3] $\frac{\sqrt{3}}{2}$ 39. [6.3] $\frac{\sqrt{2}}{2}$
 40. [6.3] $-\frac{\sqrt{3}}{2}$ 41. [6.3] $-\frac{1}{2}$ 42. [3.1] 2
 43. Use the formula for the area of a triangle and the law of sines.

$$K = \frac{1}{2} bc \sin A \quad \text{and} \quad b = \frac{c \sin B}{\sin C}$$

so $K = \frac{c^2 \sin A \sin B}{2 \sin C}$.

$K = \frac{1}{2} ab \sin C$ and $b = \frac{a \sin B}{\sin A}$,

so $K = \frac{a^2 \sin B \sin C}{2 \sin A}$.

$K = \frac{1}{2} bc \sin A$ and $c = \frac{b \sin C}{\sin B}$,

so $K = \frac{b^2 \sin A \sin C}{2 \sin B}$.

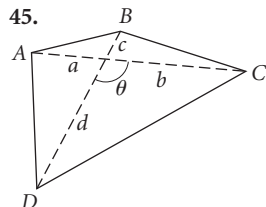

For the quadrilateral $ABCD$, we have

$$\begin{aligned} \text{Area} &= \frac{1}{2} bd \sin \theta + \frac{1}{2} ac \sin \theta \\ &+ \frac{1}{2} ad(\sin 180^\circ - \theta) + \frac{1}{2} bc \sin(180^\circ - \theta) \end{aligned}$$

Note: $\sin \theta = \sin(180^\circ - \theta)$.

$$\begin{aligned} &= \frac{1}{2} (bd + ac + ad + bc) \sin \theta \\ &= \frac{1}{2} (a + b)(c + d) \sin \theta \\ &= \frac{1}{2} d_1 d_2 \sin \theta, \end{aligned}$$

where $d_1 = a + b$ and $d_2 = c + d$.

47. 44.1" from wall 1 and 104.3" from wall 4

Exercise Set 8.2

1. $a \approx 15, B \approx 24^\circ, C \approx 126^\circ$ 3. $A \approx 36.18^\circ, B \approx 43.53^\circ, C \approx 100.29^\circ$ 5. $b \approx 75 \text{ m}, A \approx 94^\circ 51', C \approx 12^\circ 29'$
 7. $A \approx 24.15^\circ, B \approx 30.75^\circ, C \approx 125.10^\circ$ 9. No solution
 11. $A \approx 79.93^\circ, B \approx 53.55^\circ, C \approx 46.52^\circ$ 13. $c \approx 45.17 \text{ mi}, A \approx 89.3^\circ, B \approx 42.0^\circ$ 15. $a \approx 13.9 \text{ in.}, B \approx 36.127^\circ, C \approx 90.417^\circ$ 17. Law of sines; $C = 98^\circ, a \approx 96.7, c \approx 101.9$ 19. Law of cosines; $A \approx 73.71^\circ, B \approx 51.75^\circ, C \approx 54.54^\circ$ 21. Cannot be solved 23. Law of cosines; $A \approx 33.71^\circ, B \approx 107.08^\circ, C \approx 39.21^\circ$ 25. About 340 ft
 27. About 1.5 mi 29. $S \approx 112.5^\circ, T \approx 27.2^\circ, U \approx 40.3^\circ$
 31. About 912 km 33. (a) About 16 ft; (b) about 122 ft²
 35. About 4.7 cm 37. [4.1] Quartic 38. [1.3] Linear
 39. [6.5] Trigonometric 40. [5.2] Exponential
 41. [4.5] Rational 42. [4.1] Cubic 43. [5.2] Exponential
 44. [5.3] Logarithmic 45. [6.5] Trigonometric

46. [3.2] Quadratic 47. About 9386 ft 49. $A = \frac{1}{2} a^2 \sin \theta$; when $\theta = 90^\circ$

Exercise Set 8.3

1. 5;

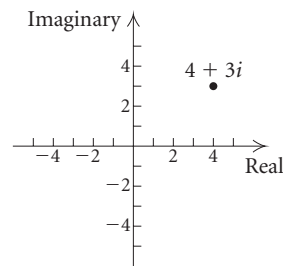

3. 1;

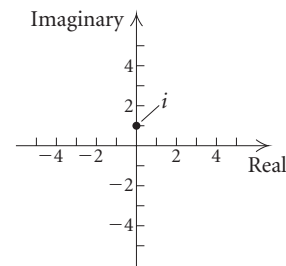

5. $\sqrt{17}$;

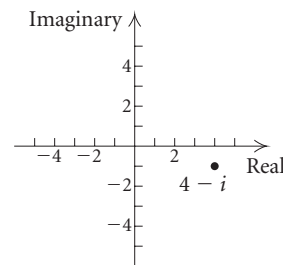

7. 3;

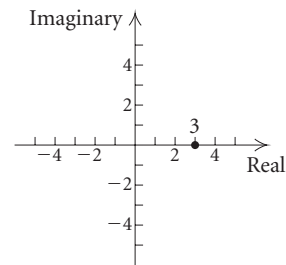

9. $3 - 3i; 3\sqrt{2} \left(\cos \frac{7\pi}{4} + i \sin \frac{7\pi}{4} \right)$, or $3\sqrt{2} (\cos 315^\circ + i \sin 315^\circ)$ 11. $4i; 4 \left(\cos \frac{\pi}{2} + i \sin \frac{\pi}{2} \right)$, or $4(\cos 90^\circ + i \sin 90^\circ)$ 13. $\sqrt{2} \left(\cos \frac{7\pi}{4} + i \sin \frac{7\pi}{4} \right)$, or $\sqrt{2} (\cos 315^\circ + i \sin 315^\circ)$ 15. $3 \left(\cos \frac{3\pi}{2} + i \sin \frac{3\pi}{2} \right)$, or $3(\cos 270^\circ + i \sin 270^\circ)$ 17. $2 \left(\cos \frac{\pi}{6} + i \sin \frac{\pi}{6} \right)$, or $2(\cos 30^\circ + i \sin 30^\circ)$ 19. $\frac{2}{5} (\cos 0 + i \sin 0)$, or $\frac{2}{5} (\cos 0^\circ + i \sin 0^\circ)$ 21. $6 \left(\cos \frac{5\pi}{4} + i \sin \frac{5\pi}{4} \right)$, or $6(\cos 225^\circ + i \sin 225^\circ)$ 23. $\frac{3\sqrt{3}}{2} + \frac{3}{2}i$ 25. $-10i$
 27. $2 + 2i$ 29. $2i$ 31. $\frac{\sqrt{2}}{2} - \frac{\sqrt{6}}{2}i$
 33. $4(\cos 42^\circ + i \sin 42^\circ)$ 35. $11.25(\cos 56^\circ + i \sin 56^\circ)$
 37. 4 39. $-i$ 41. $6 + 6\sqrt{3}i$ 43. $-2i$
 45. $8(\cos \pi + i \sin \pi)$ 47. $8 \left(\cos \frac{3\pi}{2} + i \sin \frac{3\pi}{2} \right)$
 49. $\frac{27}{2} + \frac{27\sqrt{3}}{2}i$ 51. $-4 + 4i$ 53. -1
 55. $-\frac{\sqrt{2}}{2} + \frac{\sqrt{2}}{2}i, \frac{\sqrt{2}}{2} - \frac{\sqrt{2}}{2}i$
 57. $2(\cos 157.5^\circ + i \sin 157.5^\circ), 2(\cos 337.5^\circ + i \sin 337.5^\circ)$
 59. $\frac{\sqrt{3}}{2} + \frac{1}{2}i, -\frac{\sqrt{3}}{2} + \frac{1}{2}i, -i$

61. $\sqrt[3]{4}(\cos 110^\circ + i \sin 110^\circ)$, $\sqrt[3]{4}(\cos 230^\circ + i \sin 230^\circ)$, $\sqrt[3]{4}(\cos 350^\circ + i \sin 350^\circ)$

63. $2, 2i, -2, -2i$;

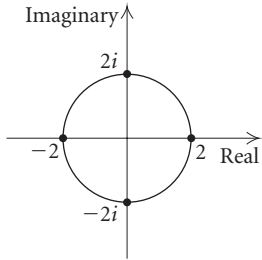

65. $\cos 36^\circ + i \sin 36^\circ$,
 $\cos 108^\circ + i \sin 108^\circ, -1$,
 $\cos 252^\circ + i \sin 252^\circ$,
 $\cos 324^\circ + i \sin 324^\circ$;

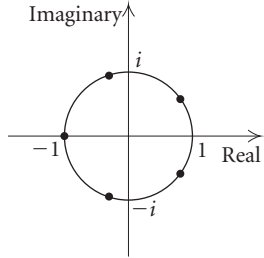

67. $\sqrt[10]{8}, \sqrt[10]{8}(\cos 36^\circ + i \sin 36^\circ), \sqrt[10]{8}(\cos 72^\circ + i \sin 72^\circ)$,
 $\sqrt[10]{8}(\cos 108^\circ + i \sin 108^\circ), \sqrt[10]{8}(\cos 144^\circ + i \sin 144^\circ), -\sqrt[10]{8}$,

$\sqrt[10]{8}(\cos 216^\circ + i \sin 216^\circ), \sqrt[10]{8}(\cos 252^\circ + i \sin 252^\circ)$,

$\sqrt[10]{8}(\cos 288^\circ + i \sin 288^\circ), \sqrt[10]{8}(\cos 324^\circ + i \sin 324^\circ)$

69. $\frac{\sqrt{3}}{2} + \frac{1}{2}i, i, -\frac{\sqrt{3}}{2} + \frac{1}{2}i, -\frac{\sqrt{3}}{2} - \frac{1}{2}i, -i, \frac{\sqrt{3}}{2} - \frac{1}{2}i$

71. $1, -\frac{1}{2} + \frac{\sqrt{3}}{2}i, -\frac{1}{2} - \frac{\sqrt{3}}{2}i$

73. $\cos 67.5^\circ + i \sin 67.5^\circ, \cos 157.5^\circ + i \sin 157.5^\circ$,

$\cos 247.5^\circ + i \sin 247.5^\circ, \cos 337.5^\circ + i \sin 337.5^\circ$

75. $\sqrt{3} + i, 2i, -\sqrt{3} + i, -\sqrt{3} - i, -2i, \sqrt{3} - i$

77. $[6.4] 15^\circ$ 78. $[6.4] 540^\circ$ 79. $[6.4] \frac{11\pi}{6}$

80. $[6.4] -\frac{5\pi}{4}$ 81. $[R.7] 3\sqrt{5}$

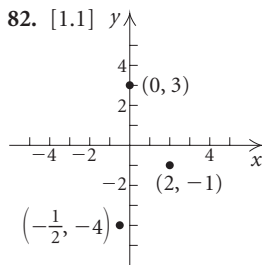

83. $[6.5] \frac{\sqrt{3}}{2}$

84. $[6.5] \frac{\sqrt{3}}{2}$

85. $[6.5] \frac{\sqrt{2}}{2}$

86. $[6.5] \frac{1}{2}$

87. $-\frac{1 + \sqrt{3}}{2} + \frac{1 + \sqrt{3}}{2}i, -\frac{1 - \sqrt{3}}{2} + \frac{1 - \sqrt{3}}{2}i$

89. $\cos \theta - i \sin \theta$ 91. $z = a + bi, |z| = \sqrt{a^2 + b^2}$;

$\bar{z} = a - bi, |\bar{z}| = \sqrt{a^2 + (-b)^2} = \sqrt{a^2 + b^2}, \therefore |z| = |\bar{z}|$

93. $|(a + bi)^2| = |a^2 - b^2 + 2abi| = \sqrt{(a^2 - b^2)^2 + 4a^2b^2}$
 $= \sqrt{a^4 + 2a^2b^2 + b^4} = a^2 + b^2$,

$|a + bi|^2 = (\sqrt{a^2 + b^2})^2 = a^2 + b^2$

95. $\frac{z}{w} = \frac{r_1(\cos \theta_1 + i \sin \theta_1)}{r_2(\cos \theta_2 + i \sin \theta_2)}$

$= \frac{r_1}{r_2}(\cos(\theta_1 - \theta_2) + i \sin(\theta_1 - \theta_2))$,

$\left| \frac{z}{w} \right| = \sqrt{\left[\frac{r_1}{r_2} \cos(\theta_1 - \theta_2) \right]^2 + \left[\frac{r_1}{r_2} \sin(\theta_1 - \theta_2) \right]^2}$

$= \sqrt{\frac{r_1^2}{r_2^2} = \frac{|r_1|}{|r_2|}}$,

$|z| = \sqrt{(r_1 \cos \theta_1)^2 + (r_1 \sin \theta_1)^2} = \sqrt{r_1^2} = |r_1|$;

$|w| = \sqrt{(r_2 \cos \theta_2)^2 + (r_2 \sin \theta_2)^2} = \sqrt{r_2^2} = |r_2|$;

Then $\left| \frac{z}{w} \right| = \frac{|r_1|}{|r_2|} = \frac{|z|}{|w|}$.

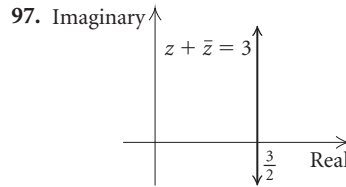

Mid-Chapter Mixed Review: Chapter 8

1. True 2. True 3. False 4. True 5. $B = 63^\circ$,
 $b \approx 9.4$ in., $c \approx 9.5$ in. 6. No solution 7. $A \approx 40.5^\circ$,

$B \approx 28.5^\circ, C \approx 111.0^\circ$ 8. $B \approx 70.2^\circ, C \approx 67.1^\circ$,
 $c \approx 39.9$ cm or $B \approx 109.8^\circ, C \approx 27.5^\circ, c \approx 20.0$ cm

9. $a \approx 370$ yd, $B \approx 16.6^\circ, C \approx 15.4^\circ$

10. $C \approx 45^\circ, A \approx 107^\circ, a \approx 37$ ft, or $C \approx 135^\circ, A \approx 17^\circ$,
 $a \approx 11$ ft 11. About 446 in²

12. Imaginary \uparrow ; $\sqrt{34}$ 13. Imaginary \uparrow ; 1

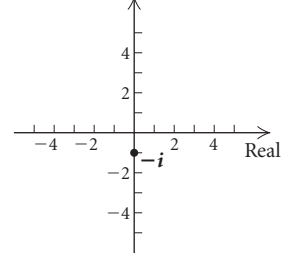
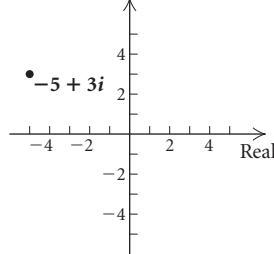

14. Imaginary \uparrow ; 4

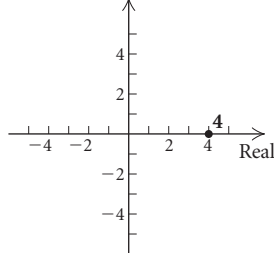

15. Imaginary \uparrow ; $\sqrt{26}$

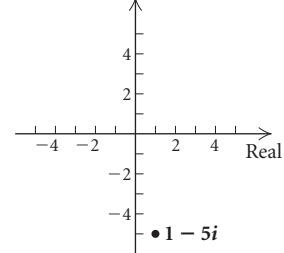

16. $\sqrt{2} \left(\cos \frac{\pi}{3} + i \sin \frac{\pi}{3} \right)$, or $\sqrt{2}(\cos 60^\circ + i \sin 60^\circ)$

17. $2 \left(\cos \frac{5\pi}{3} + i \sin \frac{5\pi}{3} \right)$, or $2(\cos 300^\circ + i \sin 300^\circ)$

18. $5 \left(\cos \frac{\pi}{2} + i \sin \frac{\pi}{2} \right)$, or $5(\cos 90^\circ + i \sin 90^\circ)$

19. $2\sqrt{2} \left(\cos \frac{5\pi}{4} + i \sin \frac{5\pi}{4} \right)$, or $2\sqrt{2}(\cos 225^\circ + i \sin 225^\circ)$

20. $\sqrt{2} - \sqrt{2}i$ 21. $6\sqrt{3} + 6i$ 22. $\sqrt{5}$ 23. $4i$
 24. $16(\cos 45^\circ + i \sin 45^\circ)$
 25. $9\left[\cos\left(\frac{\pi}{12}\right) + i \sin\left(\frac{\pi}{12}\right)\right]$
 26. $2\sqrt{2}(\cos 285^\circ + i \sin 285^\circ)$
 27. $\sqrt{2}(\cos 255^\circ + i \sin 255^\circ)$
 28. $8\sqrt{2}(\cos 45^\circ + i \sin 45^\circ)$ 29. $8 + 8\sqrt{3}i$
 30. $2(\cos 120^\circ + i \sin 120^\circ)$ and $2(\cos 300^\circ + i \sin 300^\circ)$,
 or $-1 + \sqrt{3}i$ and $1 - \sqrt{3}i$ 31. $1(\cos 60^\circ + i \sin 60^\circ)$,
 $1(\cos 180^\circ + i \sin 180^\circ)$, and $1(\cos 300^\circ + i \sin 300^\circ)$, or
 $\frac{1}{2} + \frac{\sqrt{3}}{2}i$, -1 , and $\frac{1}{2} - \frac{\sqrt{3}}{2}i$

32. Using the law of cosines, it is necessary to solve the quadratic equation:

$$(11.1)^2 = a^2 + (28.5)^2 - 2a(28.5) \cos 19^\circ, \text{ or}$$

$$0 = a^2 - [2(28.5) \cos 19^\circ]a + [(28.5)^2 - (11.1)^2].$$

The law of sines requires less complicated computations.

33. A nonzero complex number has n different complex n th roots. Thus, 1 has three different complex cube roots, one of which is the real number 1. The other two roots are complex conjugates. Since the set of real numbers is a subset of the set of complex numbers, the real cube root of 1 is also a complex root of 1. 34. The law of sines involves two angles of a triangle and the sides opposite them. Three of these four values must be known in order to find the fourth. Given SAS, only two of these four values are known. 35. The law of sines involves two angles of a triangle and the sides opposite them. Three of these four values must be known in order to find the fourth.

Thus we must know the measure of one angle in order to use the law of sines. 36. Trigonometric notation is not unique because there are infinitely many angles coterminal with a given angle. Standard notation is unique because any point has a unique ordered pair (a, b) associated with it.

37. $x^6 - 2x^3 + 1 = 0$
 $(x^3 - 1)^2 = 0$
 $x^3 - 1 = 0$
 $x^3 = 1$
 $x = 1^{1/3}$

This equation has three distinct solutions because there are three distinct cube roots of 1.

$$x^6 - 2x^3 = 0$$

$$x^3(x^3 - 2) = 0$$

$$x^3 = 0 \text{ or } x^3 - 2 = 0$$

$$x^3 = 0 \text{ or } x^3 = 2$$

$$x = 0 \text{ or } x = 2^{1/3}$$

This equation has four distinct solutions because 0 is one solution and the three distinct cube roots of 2 provide an additional three solutions.

$$x^6 - 2x = 0$$

$$x(x^5 - 2) = 0$$

$$x = 0 \text{ or } x^5 - 2 = 0$$

$$x = 0 \text{ or } x^5 = 2$$

$$x = 0 \text{ or } x = 2^{1/5}$$

This equation has six distinct solutions because 0 is one solution and the five fifth roots of 2 provide an additional five solutions.

Visualizing the Graph

1. J 2. C 3. E 4. H 5. I 6. A 7. D 8. G
 9. B 10. F

Exercise Set 8.4

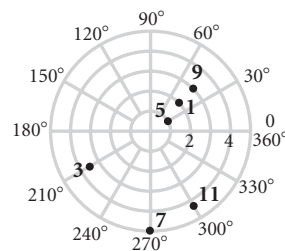

13. A: $(4, 30^\circ)$, $(4, 390^\circ)$, $(-4, 210^\circ)$; B: $(5, 300^\circ)$, $(5, -60^\circ)$, $(-5, 120^\circ)$; C: $(2, 150^\circ)$, $(2, 510^\circ)$, $(-2, 330^\circ)$; D: $(3, 225^\circ)$, $(3, -135^\circ)$, $(-3, 45^\circ)$; answers may vary

15. $(3, 270^\circ)$, $\left(3, \frac{3\pi}{2}\right)$ 17. $(6, 300^\circ)$, $\left(6, \frac{5\pi}{3}\right)$

19. $(8, 330^\circ)$, $\left(8, \frac{11\pi}{6}\right)$ 21. $(2, 225^\circ)$, $\left(2, \frac{5\pi}{4}\right)$

23. $(2, 60^\circ)$, $\left(2, \frac{\pi}{3}\right)$ 25. $(5, 315^\circ)$, $\left(5, \frac{7\pi}{4}\right)$

27. $\left(\frac{5}{2}, \frac{5\sqrt{3}}{2}\right)$ 29. $\left(-\frac{3\sqrt{2}}{2}, -\frac{3\sqrt{2}}{2}\right)$

31. $\left(-\frac{3}{2}, -\frac{3\sqrt{3}}{2}\right)$ 33. $(-1, \sqrt{3})$ 35. $(-\sqrt{3}, -1)$

37. $(3\sqrt{3}, -3)$ 39. $r(3 \cos \theta + 4 \sin \theta) = 5$

41. $r \cos \theta = 5$ 43. $r = 6$ 45. $r^2 \cos^2 \theta = 25r \sin \theta$

47. $r^2 \sin^2 \theta - 5r \cos \theta - 25 = 0$ 49. $r^2 = 2r \cos \theta$

51. $x^2 + y^2 = 25$ 53. $y = 2$ 55. $y^2 = -6x + 9$

57. $x^2 - 9x + y^2 - 7y = 0$ 59. $x = 5$ 61. $y = -\sqrt{3x}$

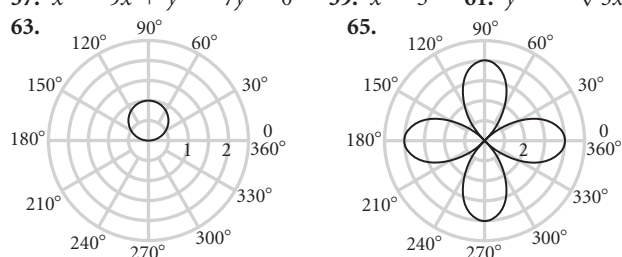

63. $r = \sin \theta$

65. $r = 4 \cos 2\theta$

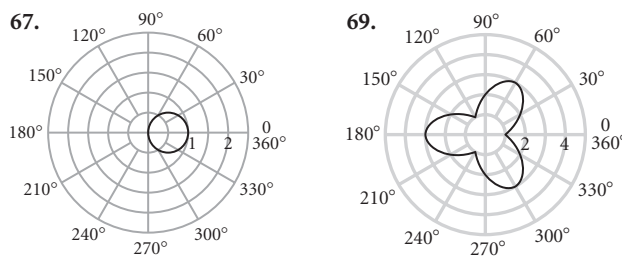

67. $r = \cos \theta$

69. $r = 2 - \cos 3\theta$

71. [1.5] 12 72. $[1.5] \frac{1}{5}$

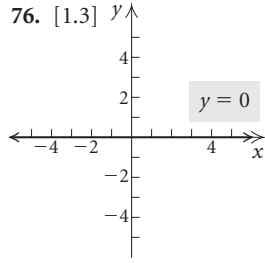
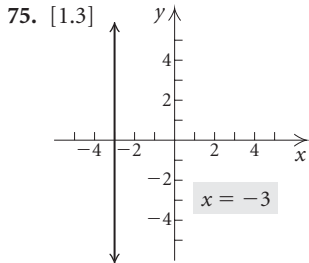
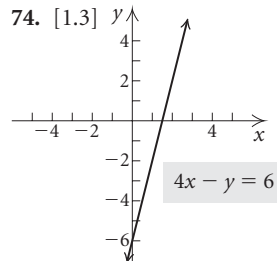
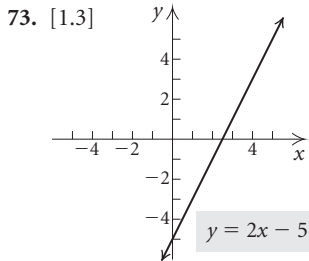

77. (d) 79. (g) 81. (j) 83. (b) 85. (e) 87. (k)
89. $y^2 = -4x + 4$

Exercise Set 8.5

1. Yes 3. No 5. Yes 7. No 9. No 11. Yes
13. 55 N, 55° 15. 929 N, 19° 17. 57.0, 38°
19. 18.4, 37° 21. 20.9, 58° 23. 68.3, 18°
25. 11 ft/sec, 63° 27. 726 lb, 47° 29. 60° 31. 70.7 east;
70.7 south 33. Horizontal: 215.17 mph forward; vertical:
65.78 mph up 35. Horizontal: 390 lb forward; vertical:
675.5 lb up 37. Northerly: 115 km/h; westerly: 164 km/h
39. Perpendicular: 90.6 lb; parallel: 42.3 lb 41. 48.1 lb
43. [5.3] Natural 44. [7.2] Half-angle 45. [6.4] Linear
speed 46. [6.1] Cosine 47. [7.1] Identity
48. [6.1] Cotangent of θ 49. [6.3] Coterminal
50. [8.1] Sines 51. [5.1] Horizontal line; inverse
52. [6.3] Reference angle; acute 53. (a) (4.950, 4.950);
(b) (0.950, -1.978)

Exercise Set 8.6

1. $\langle -9, 5 \rangle$; $\sqrt{106}$ 3. $\langle -3, 6 \rangle$; $3\sqrt{5}$ 5. $\langle 4, 0 \rangle$; 4
7. $\sqrt{37}$ 9. $\langle 4, -5 \rangle$ 11. $\sqrt{257}$ 13. $\langle -9, 9 \rangle$
15. $\langle 41, -38 \rangle$ 17. $\sqrt{261} - \sqrt{65}$ 19. $\langle -1, -1 \rangle$
21. $\langle -8, 14 \rangle$ 23. 1 25. -34

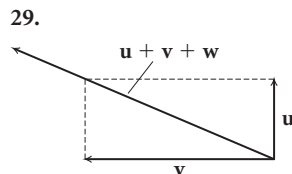
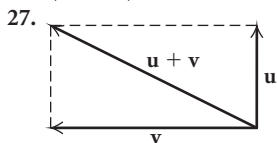

31. (a) $\mathbf{w} = \mathbf{u} + \mathbf{v}$; (b) $\mathbf{v} = \mathbf{w} - \mathbf{u}$ 33. $\langle -\frac{5}{13}, \frac{12}{13} \rangle$
35. $\langle \frac{1}{\sqrt{101}}, -\frac{10}{\sqrt{101}} \rangle$ 37. $\langle -\frac{1}{\sqrt{17}}, -\frac{4}{\sqrt{17}} \rangle$

39. $\mathbf{w} = -4\mathbf{i} + 6\mathbf{j}$ 41. $\mathbf{s} = 2\mathbf{i} + 5\mathbf{j}$ 43. $-7\mathbf{i} + 5\mathbf{j}$
45. (a) $3\mathbf{i} + 29\mathbf{j}$; (b) $\langle 3, 29 \rangle$ 47. (a) $4\mathbf{i} + 16\mathbf{j}$; (b) $\langle 4, 16 \rangle$

49. \mathbf{j} , or $\langle 0, 1 \rangle$ 51. $-\frac{1}{2}\mathbf{i} - \frac{\sqrt{3}}{2}\mathbf{j}$, or $\langle -\frac{1}{2}, -\frac{\sqrt{3}}{2} \rangle$

53. 248° 55. 63° 57. 50° 59. $|\mathbf{u}| = 3$; $\theta = 45^\circ$

61. 1; 120° 63. 144.2° 65. 14.0° 67. 101.3°

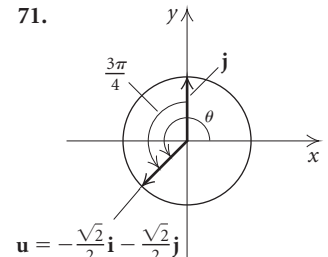
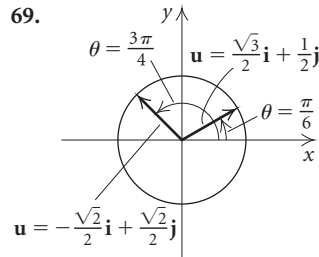

73. $\mathbf{u} = -\frac{\sqrt{10}}{10}\mathbf{i} + \frac{3\sqrt{10}}{10}\mathbf{j}$

75. $\sqrt{13} \left(\frac{2\sqrt{13}}{13}\mathbf{i} - \frac{3\sqrt{13}}{13}\mathbf{j} \right)$

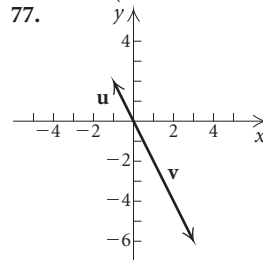

79. 174 nautical mi, $S17^\circ E$
81. 60° 83. 500 lb on left, 866 lb on right
85. Cable: 224-lb tension; boom: 167-lb compression

87. $\mathbf{u} + \mathbf{v} = \langle u_1, u_2 \rangle + \langle v_1, v_2 \rangle$
 $= \langle u_1 + v_1, u_2 + v_2 \rangle$
 $= \langle v_1 + u_1, v_2 + u_2 \rangle$
 $= \langle v_1, v_2 \rangle + \langle u_1, u_2 \rangle$
 $= \mathbf{v} + \mathbf{u}$

89. [1.3] $-\frac{1}{5}$; (0, -15) 90. [1.3] 0; (0, 7) 91. [4.1] 0, 4

92. [3.2] $-\frac{11}{3}, \frac{5}{2}$ 93. (a) $\cos \theta = \frac{\mathbf{u} \cdot \mathbf{v}}{|\mathbf{u}||\mathbf{v}|} = \frac{0}{|\mathbf{u}||\mathbf{v}|}$
 $\therefore \cos \theta = 0$ and $\theta = 90^\circ$. (b) Answers may vary. $\mathbf{u} = \langle 2, -3 \rangle$
and $\mathbf{v} = \langle -3, -2 \rangle$; $\mathbf{u} \cdot \mathbf{v} = 2(-3) + (-3)(-2) = 0$

95. $\frac{3}{5}\mathbf{i} - \frac{4}{5}\mathbf{j}$; $-\frac{3}{5}\mathbf{i} + \frac{4}{5}\mathbf{j}$ 97. (5, 8)

Review Exercises: Chapter 8

1. True 2. False 3. False 4. False 5. False
6. True 7. $A \approx 153^\circ, B \approx 18^\circ, C \approx 9^\circ$ 8. $A = 118^\circ$,
 $a \approx 37$ in., $c \approx 24$ in. 9. $B = 14^\circ 50'$, $a \approx 2523$ m,
 $c \approx 1827$ m 10. No solution 11. 33 m^2 12. 13.72 ft^2
13. 63 ft^2 14. $92^\circ, 33^\circ, 55^\circ$ 15. 419 ft
16. About 650 km

17. $\sqrt{29}$;

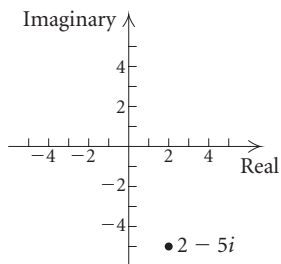

18. 4;

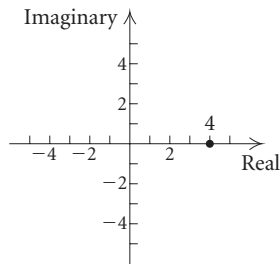

19. 2;

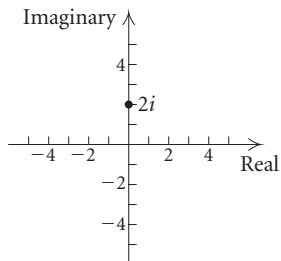

20. $\sqrt{10}$;

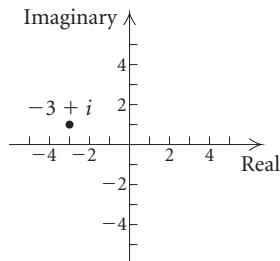

21. $\sqrt{2}\left(\cos \frac{\pi}{4} + i \sin \frac{\pi}{4}\right)$, or $\sqrt{2}(\cos 45^\circ + i \sin 45^\circ)$

22. $4\left(\cos \frac{3\pi}{2} + i \sin \frac{3\pi}{2}\right)$, or $4(\cos 270^\circ + i \sin 270^\circ)$

23. $10\left(\cos \frac{5\pi}{6} + i \sin \frac{5\pi}{6}\right)$, or $10(\cos 150^\circ + i \sin 150^\circ)$

24. $\frac{3}{4}(\cos 0 + i \sin 0)$, or $\frac{3}{4}(\cos 0^\circ + i \sin 0^\circ)$

25. $2 + 2\sqrt{3}i$ 26. 7 27. $-\frac{5}{2} + \frac{5\sqrt{3}}{2}i$ 28. $\sqrt{3} - i$

29. $1 + \sqrt{3} + (-1 + \sqrt{3})i$ 30. $-i$ 31. $2i$

32. $3\sqrt{3} + 3i$ 33. $8(\cos 180^\circ + i \sin 180^\circ)$

34. $4(\cos 7\pi + i \sin 7\pi)$ 35. $-8i$ 36. $-\frac{1}{2} - \frac{\sqrt{3}}{2}i$

37. $\sqrt[4]{2}\left(\cos \frac{3\pi}{8} + i \sin \frac{3\pi}{8}\right)$, $\sqrt[4]{2}\left(\cos \frac{11\pi}{8} + i \sin \frac{11\pi}{8}\right)$

38. $\sqrt[3]{6}(\cos 110^\circ + i \sin 110^\circ)$, $\sqrt[3]{6}(\cos 230^\circ + i \sin 230^\circ)$, $\sqrt[3]{6}(\cos 350^\circ + i \sin 350^\circ)$

39. $3, 3i, -3, -3i$

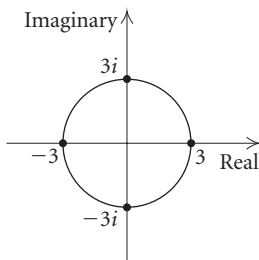

40. $1, \cos 72^\circ + i \sin 72^\circ$,
 $\cos 144^\circ + i \sin 144^\circ$,
 $\cos 216^\circ + i \sin 216^\circ$,
 $\cos 288^\circ + i \sin 288^\circ$

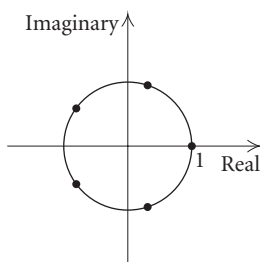

41. $\cos 22.5^\circ + i \sin 22.5^\circ, \cos 112.5^\circ + i \sin 112.5^\circ$,
 $\cos 202.5^\circ + i \sin 202.5^\circ, \cos 292.5^\circ + i \sin 292.5^\circ$

42. $\frac{1}{2} + \frac{\sqrt{3}}{2}i, -1, \frac{1}{2} - \frac{\sqrt{3}}{2}i$ 43. A: $(5, 120^\circ), (5, 480^\circ)$,
 $(-5, 300^\circ)$; B: $(3, 210^\circ), (-3, 30^\circ), (-3, 390^\circ)$; C: $(4, 60^\circ)$,
 $(4, 420^\circ), (-4, 240^\circ)$; D: $(1, 300^\circ), (1, -60^\circ), (-1, 120^\circ)$;

answers may vary 44. $(8, 135^\circ), \left(8, \frac{3\pi}{4}\right)$

45. $(5, 270^\circ), \left(5, \frac{3\pi}{2}\right)$ 46. $(5.385, 111.8^\circ), (5.385, 1.951)$

47. $(4.964, 147.8^\circ), (4.964, 2.579)$ 48. $\left(\frac{3\sqrt{2}}{2}, \frac{3\sqrt{2}}{2}\right)$

49. $(3, 3\sqrt{3})$ 50. $(1.93, -0.52)$ 51. $(-1.86, -1.35)$

52. $r(5 \cos \theta - 2 \sin \theta) = 6$ 53. $r \sin \theta = 3$ 54. $r = 3$

55. $r^2 \sin^2 \theta - 4r \cos \theta - 16 = 0$ 56. $x^2 + y^2 = 36$

57. $x^2 + 2y = 1$ 58. $y^2 - 6x = 9$

59. $x^2 - 2x + y^2 - 3y = 0$ 60. (b) 61. (d) 62. (a)

63. (c) 64. $13.7, 71^\circ$ 65. $98.7, 15^\circ$

66.

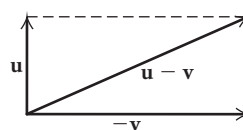

67.

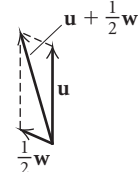

68. 666.7 N, 36° 69. 29 km/h, 149° 70. 102.4 nautical mi,

$S43^\circ E$ 71. $(-4, 3)$ 72. $(2, -6)$ 73. $\sqrt{61}$

74. $(10, -21)$ 75. $(14, -64)$ 76. $5 + \sqrt{116}$ 77. 14

78. $\left\langle -\frac{3}{\sqrt{10}}, -\frac{1}{\sqrt{10}} \right\rangle$ 79. $-9i + 4j$ 80. 194.0°

81. $\sqrt{34}; \theta = 211.0^\circ$ 82. 111.8° 83. 85.1°

84. $34i - 55j$ 85. $i - 12j$ 86. $5\sqrt{2}$

87. $3\sqrt{65} + \sqrt{109}$ 88. $-5i + 5j$

89.

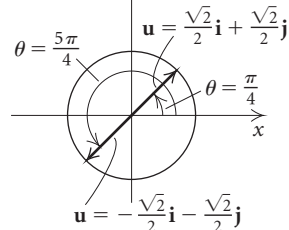

90.

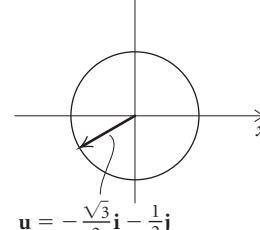

91. $\sqrt{10}\left(\frac{3\sqrt{10}}{10}i - \frac{\sqrt{10}}{10}j\right)$ 92. D 93. A 94. D

95. $\frac{36}{13}i + \frac{15}{13}j$ 96. $50.52^\circ, 129.48^\circ$ 97. A triangle has no solution when a sine value or a cosine value found is less than -1 or greater than 1 . A triangle also has no solution if the sum of the angle measures calculated is greater than 180° . A triangle has only one solution if only one possible answer is found, or if one of the possible answers has an angle sum greater than 180° . A triangle has two solutions when two possible answers are found and neither results in an angle sum greater than 180° .

98. One example is the equation of a circle not centered at the origin. Often, in rectangular coordinates, we must complete the square in order to graph the circle. 99. Rectangular coordinates are unique because any point has a unique ordered pair (x, y) associated with it. Polar coordinates are not unique because there are infinitely many angles coterminal with a given angle and also because r can be positive or negative depending on the angle used. 100. Vectors \overrightarrow{QR} and \overrightarrow{RQ} have opposite directions, so they are not equivalent. 101. The terminal point of a unit vector in standard position is a point on the unit circle. 102. Answers may vary. For $\mathbf{u} = 3\mathbf{i} - 4\mathbf{j}$ and $\mathbf{w} = 2\mathbf{i} - 4\mathbf{j}$, find \mathbf{v} , where $\mathbf{v} = \mathbf{u} + \mathbf{w}$.

Test: Chapter 8

1. [8.1] $A = 83^\circ, b \approx 14.7 \text{ ft}, c \approx 12.4 \text{ ft}$
 2. [8.1] $A \approx 73.9^\circ, B \approx 70.1^\circ, a \approx 8.2 \text{ m}, \text{ or } A \approx 34.1^\circ, B \approx 109.9^\circ, a \approx 4.8 \text{ m}$ 3. [8.2] $A \approx 99.9^\circ, B \approx 36.8^\circ, C \approx 43.3^\circ$ 4. [8.1] About 43.6 cm^2 5. [8.1] About 77 m
 6. [8.5] About 930 km
 7. [8.3]

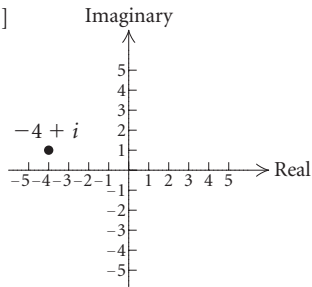

8. [8.3] $\sqrt{13}$ 9. [8.3] $3\sqrt{2}(\cos 315^\circ + i \sin 315^\circ)$, or $3\sqrt{2}\left(\cos \frac{7\pi}{4} + i \sin \frac{7\pi}{4}\right)$ 10. [8.3] $\frac{1}{4}i$ 11. [8.3] 16
 12. [8.4] $2(\cos 120^\circ + i \sin 120^\circ)$ 13. [8.4] $\left(\frac{1}{2}, -\frac{\sqrt{3}}{2}\right)$

14. [8.4] $r = \sqrt{10}$
 15. [8.4]

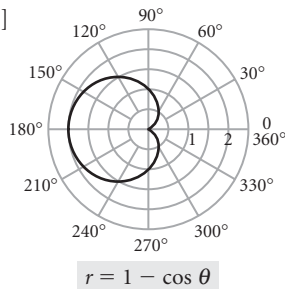

16. [8.5] Magnitude: 11.2 ; direction: 23.4°
 17. [8.6] $-11\mathbf{i} - 17\mathbf{j}$ 18. [8.6] $-\frac{4}{5}\mathbf{i} + \frac{3}{5}\mathbf{j}$
 19. [8.4] A 20. [8.1] $28.9^\circ, 151.1^\circ$

Chapter 9

Visualizing the Graph

1. C 2. G 3. D 4. J 5. A 6. F 7. I
 8. B 9. H 10. E

Exercise Set 9.1

1. (c) 3. (f) 5. (b) 7. $(-1, 3)$ 9. $(-1, 1)$
 11. No solution 13. $(-2, 4)$ 15. Infinitely many solutions; $\left(x, \frac{x-1}{2}\right)$ or $(2y+1, y)$ 17. $(5, 4)$ 19. $(1, -3)$
 21. $(2, -2)$ 23. No solution 25. $\left(\frac{39}{11}, -\frac{1}{11}\right)$ 27. $\left(\frac{1}{2}, \frac{3}{4}\right)$
 29. Infinitely many solutions; $(x, 3x-5)$ or $\left(\frac{1}{3}y + \frac{5}{3}, y\right)$
 31. $(1, 3)$; consistent, independent 33. $(-4, -2)$; consistent, independent 35. Infinitely many solutions; $(4y+2, y)$ or $\left(x, \frac{1}{4}x - \frac{1}{2}\right)$; consistent, dependent 37. No solution; inconsistent, independent 39. $(1, 1)$; consistent, independent 41. $(-3, 0)$; consistent, independent 43. $(10, 8)$; consistent, independent 45. True 47. False 49. True 51. Cell-phone providers: $37,477$ complaints; cable/satellite TV providers: $32,616$ complaints 53. Knee replacements: 3.5 million; hip replacements: 0.572 million, or $572,000$ 55. Skiing: $144,400$ injuries; snowboarding: $144,000$ injuries 57. Standard: 76 packages; express: 44 packages 59. 4%: $\$6000$; 5%: $\$9000$ 61. 6 lb of French roast, 4 lb of Kenyan 63. 1.5 servings of spaghetti, 2 servings of lettuce 65. Boat: 20 km/h ; stream: 3 km/h 67. 2 hr 69. $(15, \$100)$ 71. 140 73. 6000
 75. [1.5] About 838.3 million travelers 76. [1.5] About $\$44.5$ billion 77. [3.2] $-2, 6$ 78. [3.2] $-1, 5$
 79. [1.2] 15 80. [3.2] 1, 3 81. 4 km 83. First train: 36 km/h ; second train: 54 km/h 85. $A = \frac{1}{10}, B = -\frac{7}{10}$
 87. City: 294 mi ; highway: 153 mi

Exercise Set 9.2

1. $(3, -2, 1)$ 3. $(-3, 2, 1)$ 5. $\left(2, \frac{1}{2}, -2\right)$
 7. No solution 9. Infinitely many solutions; $\left(\frac{11y+19}{5}, y, \frac{9y+11}{5}\right)$ 11. $\left(\frac{1}{2}, \frac{2}{3}, -\frac{5}{6}\right)$ 13. $(-1, 4, 3)$
 15. $(1, -2, 4, -1)$ 17. North America: 6 sites; Europe: 13 sites; Asia: 2 sites 19. In a restaurant: 78 meals; in a car: 34 meals; at home: 58 meals 21. Brewed coffee: 80 mg; Red Bull: 80 mg; Mountain Dew: 37 mg 23. Fish: 183 million; cats: 94 million; dogs: 78 million 25. *The Dark Knight*: $\$158$ million; *Spider-Man 3*: $\$151$ million; *The Twilight Saga: New Moon*: $\$143$ million 27. $1\frac{1}{4}$ servings of beef, 1 baked potato, $\frac{3}{4}$ serving of strawberries 29. 3%: $\$1300$; 4%: $\$900$; 6%: $\$2800$ 31. Orange juice: $\$1.60$; bagel: $\$2.25$; coffee: $\$1.50$ 33. (a) $f(x) = \frac{5}{52}x^2 - \frac{87}{52}x + 16$; (b) 10.5%
 35. (a) $f(x) = -0.66x^2 + 5.3x + 431$, or $f(x) = -\frac{33}{50}x^2 + \frac{53}{10}x + 431$; (b) about 400 acres 37. [1.4] Perpendicular
 38. [4.1] The leading-term test 39. [1.2] A vertical line
 40. [5.1] A one-to-one function 41. [4.5] A rational function 42. [2.5] Inverse variation 43. [4.5] A vertical asymptote 44. [4.5] A horizontal asymptote
 45. $\left(-1, \frac{1}{5}, -\frac{1}{2}\right)$ 47. 180° 49. $3x + 4y + 2z = 12$

51. $y = -4x^3 + 5x^2 - 3x + 1$ 53. Adults: 5; students: 1; children: 94

Exercise Set 9.3

1. 3×2 3. 1×4 5. 3×3 7. $\begin{bmatrix} 2 & -1 & | & 7 \\ 1 & 4 & | & -5 \end{bmatrix}$

9. $\begin{bmatrix} 1 & -2 & 3 & | & 12 \\ 2 & 0 & -4 & | & 8 \\ 0 & 3 & 1 & | & 7 \end{bmatrix}$

11. $3x - 5y = 1,$
 $x + 4y = -2$

13. $2x + y - 4z = 12,$
 $3x + 5z = -1,$
 $x - y + z = 2$ 15. $(\frac{3}{2}, \frac{5}{2})$ 17. $(-\frac{63}{29}, -\frac{114}{29})$
19. $(-1, \frac{5}{2})$ 21. $(0, 3)$
23. No solution

25. Infinitely many solutions; $(3y - 2, y)$

27. $(-1, 2, -2)$ 29. $(\frac{3}{2}, -4, 3)$ 31. $(-1, 6, 3)$

33. Infinitely many solutions; $(\frac{1}{2}z + \frac{1}{2}, -\frac{1}{2}z - \frac{1}{2}, z)$

35. Infinitely many solutions; $(r - 2, -2r + 3, r)$

37. No solution 39. $(1, -3, -2, -1)$ 41. 8%: \$8000;
10%: \$12,000; 12%: \$10,000 43. 1:00 A.M.

45. [5.2] Exponential 46. [1.3] Linear 47. [4.5] Rational

48. [4.1] Quartic 49. [5.3] Logarithmic 50. [4.1] Cubic

51. [1.3] Linear 52. [3.2] Quadratic

53. $y = 3x^2 + \frac{5}{2}x - \frac{15}{2}$ 55. $\begin{bmatrix} 1 & 5 \\ 0 & 1 \end{bmatrix}, \begin{bmatrix} 1 & 0 \\ 0 & 1 \end{bmatrix}$

57. $(-\frac{4}{3}, -\frac{1}{3}, 1)$ 59. Infinitely many solutions;

$(-\frac{14}{13}z - 1, \frac{3}{13}z - 2, z)$ 61. $(-3, 3)$

Exercise Set 9.4

1. $x = -3, y = 5$ 3. $x = -1, y = 1$ 5. $\begin{bmatrix} -2 & 7 \\ 6 & 2 \end{bmatrix}$

7. $\begin{bmatrix} 1 & 3 \\ 2 & 6 \end{bmatrix}$ 9. $\begin{bmatrix} 9 & 9 \\ -3 & -3 \end{bmatrix}$ 11. $\begin{bmatrix} 11 & 13 \\ 5 & 3 \end{bmatrix}$

13. $\begin{bmatrix} -4 & 3 \\ -2 & -4 \end{bmatrix}$ 15. $\begin{bmatrix} 17 & 9 \\ -2 & 1 \end{bmatrix}$ 17. $\begin{bmatrix} 0 & 0 \\ 0 & 0 \end{bmatrix}$

19. $\begin{bmatrix} 1 & 2 \\ 4 & 3 \end{bmatrix}$ 21. $\begin{bmatrix} 1 \\ 40 \end{bmatrix}$ 23. $\begin{bmatrix} -10 & 28 \\ 14 & -26 \\ 0 & -6 \end{bmatrix}$ 25. Not

defined 27. $\begin{bmatrix} 3 & 16 & 3 \\ 0 & -32 & 0 \\ -6 & 4 & 5 \end{bmatrix}$ 29. (a) $[300 \ 80 \ 40];$

(b) $[315 \ 84 \ 42];$ (c) $[615 \ 164 \ 82];$
the total budget for each area in June and July

31. (a) $C = [140 \ 27 \ 3 \ 13 \ 64],$
 $P = [180 \ 4 \ 11 \ 24 \ 662], B = [50 \ 5 \ 1 \ 82 \ 20];$
(b) $[650 \ 50 \ 28 \ 307 \ 1448];$ the total nutritional value
of a meal of 1 serving of chicken, 1 cup of potato salad, and
3 broccoli spears

33. (a) $\begin{bmatrix} 1.50 & 0.15 & 0.26 & 0.23 & 0.64 \\ 1.55 & 0.14 & 0.24 & 0.21 & 0.75 \\ 1.62 & 0.22 & 0.31 & 0.28 & 0.53 \\ 1.70 & 0.20 & 0.29 & 0.33 & 0.68 \end{bmatrix};$

(b) $[65 \ 48 \ 93 \ 57];$

(c) $[419.46 \ 48.33 \ 73.78 \ 69.88 \ 165.65];$

(d) the total cost, in dollars, for each item for the day's meals

35. (a) $\begin{bmatrix} 8 & 15 \\ 6 & 10 \\ 4 & 3 \end{bmatrix};$ (b) $[4 \ 2.50 \ 3];$ (c) $[59 \ 94];$

(d) the total cost, in dollars, of ingredients for each coffee shop

37. (a) $[6 \ 4.50 \ 5.20];$ (b) $PS = [95.80 \ 150.60]$

39. $\begin{bmatrix} 2 & -3 \\ 1 & 5 \end{bmatrix} \begin{bmatrix} x \\ y \end{bmatrix} = \begin{bmatrix} 7 \\ -6 \end{bmatrix}$

41. $\begin{bmatrix} 1 & 1 & -2 \\ 3 & -1 & 1 \\ 2 & 5 & -3 \end{bmatrix} \begin{bmatrix} x \\ y \\ z \end{bmatrix} = \begin{bmatrix} 6 \\ 7 \\ 8 \end{bmatrix}$

43. $\begin{bmatrix} 3 & -2 & 4 \\ 2 & 1 & -5 \end{bmatrix} \begin{bmatrix} x \\ y \\ z \end{bmatrix} = \begin{bmatrix} 17 \\ 13 \end{bmatrix}$

45. $\begin{bmatrix} -4 & 1 & -1 & 2 \\ 1 & 2 & -1 & -1 \\ -1 & 1 & 4 & -3 \\ 2 & 3 & 5 & -7 \end{bmatrix} \begin{bmatrix} w \\ x \\ y \\ z \end{bmatrix} = \begin{bmatrix} 12 \\ 0 \\ 1 \\ 9 \end{bmatrix}$

47. [3.3]

(a) $(\frac{1}{2}, -\frac{25}{4});$

(b) $x = \frac{1}{2};$

(c) minimum: $-\frac{25}{4};$

(d)

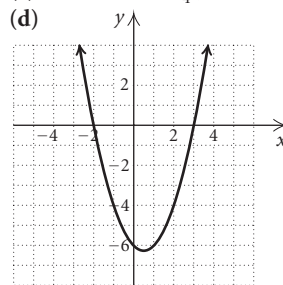

$f(x) = x^2 - x - 6$

48. [3.3]

(a) $(\frac{5}{4}, -\frac{49}{8});$

(b) $x = \frac{5}{4};$

(c) minimum: $-\frac{49}{8};$

(d)

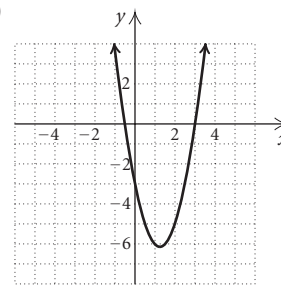

$f(x) = 2x^2 - 5x - 3$

49. [3.3]

(a) $(-\frac{3}{2}, \frac{17}{4});$

(b) $x = -\frac{3}{2};$

(c) maximum: $\frac{17}{4};$

(d)

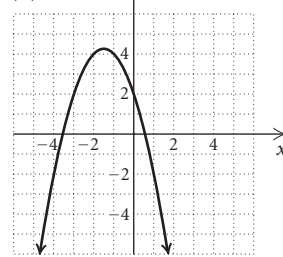

$f(x) = -x^2 - 3x + 2$

50. [3.3]

(a) $(\frac{2}{3}, \frac{16}{3});$

(b) $x = \frac{2}{3};$

(c) maximum: $\frac{16}{3};$

(d)

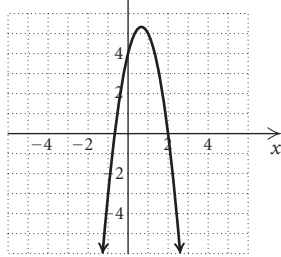

$f(x) = -3x^2 + 4x + 4$

51. $(\mathbf{A} + \mathbf{B})(\mathbf{A} - \mathbf{B}) = \begin{bmatrix} -2 & 1 \\ 2 & -1 \end{bmatrix}; \mathbf{A}^2 - \mathbf{B}^2 = \begin{bmatrix} 0 & 3 \\ 0 & -3 \end{bmatrix}$

53. $(\mathbf{A} + \mathbf{B})(\mathbf{A} - \mathbf{B}) = \begin{bmatrix} -2 & 1 \\ 2 & -1 \end{bmatrix}$
 $= \mathbf{A}^2 + \mathbf{BA} - \mathbf{AB} - \mathbf{B}^2$

55. $\mathbf{A} + \mathbf{B} = \begin{bmatrix} a_{11} + b_{11} & a_{12} + b_{12} & a_{13} + b_{13} & \cdots & a_{1n} + b_{1n} \\ a_{21} + b_{21} & a_{22} + b_{22} & a_{23} + b_{23} & \cdots & a_{2n} + b_{2n} \\ a_{31} + b_{31} & a_{32} + b_{32} & a_{33} + b_{33} & \cdots & a_{3n} + b_{3n} \\ \vdots & \vdots & \vdots & \ddots & \vdots \\ a_{m1} + b_{m1} & a_{m2} + b_{m2} & a_{m3} + b_{m3} & \cdots & a_{mn} + b_{mn} \end{bmatrix}$
 $= \begin{bmatrix} b_{11} + a_{11} & b_{12} + a_{12} & b_{13} + a_{13} & \cdots & b_{1n} + a_{1n} \\ b_{21} + a_{21} & b_{22} + a_{22} & b_{23} + a_{23} & \cdots & b_{2n} + a_{2n} \\ b_{31} + a_{31} & b_{32} + a_{32} & b_{33} + a_{33} & \cdots & b_{3n} + a_{3n} \\ \vdots & \vdots & \vdots & \ddots & \vdots \\ b_{m1} + a_{m1} & b_{m2} + a_{m2} & b_{m3} + a_{m3} & \cdots & b_{mn} + a_{mn} \end{bmatrix}$
 $= \mathbf{B} + \mathbf{A}$

57. $(kl)\mathbf{A} = \begin{bmatrix} (kl)a_{11} & (kl)a_{12} & (kl)a_{13} & \cdots & (kl)a_{1n} \\ (kl)a_{21} & (kl)a_{22} & (kl)a_{23} & \cdots & (kl)a_{2n} \\ (kl)a_{31} & (kl)a_{32} & (kl)a_{33} & \cdots & (kl)a_{3n} \\ \vdots & \vdots & \vdots & \ddots & \vdots \\ (kl)a_{m1} & (kl)a_{m2} & (kl)a_{m3} & \cdots & (kl)a_{mn} \end{bmatrix}$
 $= \begin{bmatrix} k(la_{11}) & k(la_{12}) & k(la_{13}) & \cdots & k(la_{1n}) \\ k(la_{21}) & k(la_{22}) & k(la_{23}) & \cdots & k(la_{2n}) \\ k(la_{31}) & k(la_{32}) & k(la_{33}) & \cdots & k(la_{3n}) \\ \vdots & \vdots & \vdots & \ddots & \vdots \\ k(la_{m1}) & k(la_{m2}) & k(la_{m3}) & \cdots & k(la_{mn}) \end{bmatrix}$
 $= k \begin{bmatrix} la_{11} & la_{12} & la_{13} & \cdots & la_{1n} \\ la_{21} & la_{22} & la_{23} & \cdots & la_{2n} \\ la_{31} & la_{32} & la_{33} & \cdots & la_{3n} \\ \vdots & \vdots & \vdots & \ddots & \vdots \\ la_{m1} & la_{m2} & la_{m3} & \cdots & la_{mn} \end{bmatrix}$
 $= k(l\mathbf{A})$

59. $(k + l)\mathbf{A} = \begin{bmatrix} (k + l)a_{11} & (k + l)a_{12} & (k + l)a_{13} & \cdots & (k + l)a_{1n} \\ (k + l)a_{21} & (k + l)a_{22} & (k + l)a_{23} & \cdots & (k + l)a_{2n} \\ (k + l)a_{31} & (k + l)a_{32} & (k + l)a_{33} & \cdots & (k + l)a_{3n} \\ \vdots & \vdots & \vdots & \ddots & \vdots \\ (k + l)a_{m1} & (k + l)a_{m2} & (k + l)a_{m3} & \cdots & (k + l)a_{mn} \end{bmatrix}$
 $= \begin{bmatrix} ka_{11} + la_{11} & ka_{12} + la_{12} & ka_{13} + la_{13} & \cdots & ka_{1n} + la_{1n} \\ ka_{21} + la_{21} & ka_{22} + la_{22} & ka_{23} + la_{23} & \cdots & ka_{2n} + la_{2n} \\ ka_{31} + la_{31} & ka_{32} + la_{32} & ka_{33} + la_{33} & \cdots & ka_{3n} + la_{3n} \\ \vdots & \vdots & \vdots & \ddots & \vdots \\ ka_{m1} + la_{m1} & ka_{m2} + la_{m2} & ka_{m3} + la_{m3} & \cdots & ka_{mn} + la_{mn} \end{bmatrix}$
 $= k\mathbf{A} + l\mathbf{A}$

Mid-Chapter Mixed Review: Chapter 9

1. False 2. True 3. True 4. False 5. $(-3, 2)$
 6. No solution 7. $(1, -2)$ 8. Infinitely many solutions;

$\left(x, \frac{x-1}{3}\right)$ or $(3y + 1, y)$ 9. $\left(\frac{1}{3}, -\frac{1}{6}, \frac{4}{3}\right)$ 10. Under

10 lb: 60 packages; 10 lb up to 15 lb: 70 packages; 15 lb or more: 20 packages 11. $(4, -3)$ 12. $(-3, 2, -1)$

13. $\begin{bmatrix} 1 & 5 \\ 6 & 1 \end{bmatrix}$ 14. $\begin{bmatrix} -5 & 7 \\ -4 & -7 \end{bmatrix}$ 15. $\begin{bmatrix} -8 & 12 & 0 \\ 4 & -4 & 8 \\ -12 & 16 & 4 \end{bmatrix}$

16. $\begin{bmatrix} 0 & 16 \\ 13 & -1 \end{bmatrix}$ 17. $\begin{bmatrix} -7 & 21 \\ -6 & 18 \end{bmatrix}$ 18. $\begin{bmatrix} 24 & 26 \\ -12 & -13 \end{bmatrix}$

19. $\begin{bmatrix} 20 & 16 & -10 \\ -10 & -8 & 5 \end{bmatrix}$ 20. Not defined

21. $\begin{bmatrix} 2 & -1 & 3 \\ 1 & 2 & -1 \\ 3 & -4 & 2 \end{bmatrix} \begin{bmatrix} x \\ y \\ z \end{bmatrix} = \begin{bmatrix} 7 \\ 3 \\ 5 \end{bmatrix}$

22. When a variable is not alone on one side of an equation or when solving for a variable is difficult or produces an expression containing fractions, the elimination method is preferable to the substitution method.

23. Add a nonzero multiple of one equation to a nonzero multiple of the other equation, where the multiples are not opposites.

24. See Example 4 in Section 9.3.

25. No; see Exercise 17 in Section 9.4, for example.

Exercise Set 9.5

1. Yes 3. No 5. $\begin{bmatrix} -3 & 2 \\ 5 & -3 \end{bmatrix}$ 7. Does not exist

9. $\begin{bmatrix} \frac{2}{5} & -\frac{3}{5} \\ \frac{1}{5} & -\frac{4}{5} \end{bmatrix}$ 11. $\begin{bmatrix} \frac{3}{8} & -\frac{1}{4} & \frac{1}{8} \\ -\frac{1}{8} & \frac{3}{4} & -\frac{3}{8} \\ -\frac{1}{4} & \frac{1}{2} & \frac{1}{4} \end{bmatrix}$ 13. Does not exist

15. $\begin{bmatrix} -1 & -1 & -6 \\ 1 & 0 & 2 \\ 0 & 1 & 3 \end{bmatrix}$ 17. $\begin{bmatrix} 1 & 1 & 2 \\ 1 & 1 & 1 \\ 2 & 3 & 4 \end{bmatrix}$

19. Does not exist 21. $\begin{bmatrix} 1 & -2 & 3 & 8 \\ 0 & 1 & -3 & 1 \\ 0 & 0 & 1 & -2 \\ 0 & 0 & 0 & -1 \end{bmatrix}$

23. $\begin{bmatrix} 0.25 & 0.25 & 1.25 & -0.25 \\ 0.5 & 1.25 & 1.75 & -1 \\ -0.25 & -0.25 & -0.75 & 0.75 \\ 0.25 & 0.5 & 0.75 & -0.5 \end{bmatrix}$ 25. $(-23, 83)$

27. $(-1, 5, 1)$ 29. $(2, -2)$ 31. $(0, 2)$

33. $(3, -3, -2)$ 35. $(-1, 0, 1)$ 37. $(1, -1, 0, 1)$

39. Sausages: 50; hot dogs: 95

41. Topsoil: \$239; mulch: \$179; pea gravel: \$222

43. [4.3] -48 44. [4.3] 194 45. [3.2] $\frac{-1 \pm \sqrt{57}}{4}$

46. [3.4] -3, -2 47. [3.4] 4 48. [3.4] 9

49. [4.3] $(x + 2)(x - 1)(x - 4)$

50. [4.3] $(x + 5)(x + 1)(x - 1)(x - 3)$

51. A^{-1} exists if and only if $x \neq 0$. $A^{-1} = \begin{bmatrix} 1 \\ x \end{bmatrix}$

53. A^{-1} exists if and only if $xyz \neq 0$. $A^{-1} = \begin{bmatrix} 0 & 0 & \frac{1}{z} \\ 0 & \frac{1}{y} & 0 \\ \frac{1}{x} & 0 & 0 \end{bmatrix}$

Exercise Set 9.6

1. -14 3. -2 5. -11 7. $x^3 - 4x$

9. $M_{11} = 6, M_{32} = -9, M_{22} = -29$

11. $A_{11} = 6, A_{32} = 9, A_{22} = -29$

13. -10 15. -10 17. $M_{12} = 32, M_{44} = 7$

19. $A_{22} = -10, A_{34} = 1$ 21. 110 23. -109

25. $-x^4 + x^2 - 5x$ 27. $(-\frac{25}{2}, -\frac{11}{2})$ 29. (3, 1)

31. $(\frac{1}{2}, -\frac{1}{3})$ 33. (1, 1) 35. $(\frac{3}{2}, \frac{13}{14}, \frac{33}{14})$ 37. (3, -2, 1)

39. (1, 3, -2) 41. $(\frac{1}{2}, \frac{2}{3}, -\frac{5}{6})$ 43. [5.1] $f^{-1}(x) = \frac{x - 2}{3}$

44. [5.1] Not one-to-one 45. [5.1] Not one-to-one

46. [5.1] $f^{-1}(x) = (x - 1)^3$ 47. [3.1] $5 - 3i$

48. [3.1] $6 - 2i$ 49. [3.1] $10 - 10i$ 50. [3.1] $\frac{9}{25} + \frac{13}{25}i$

51. ± 2 53. $(-\infty, -\sqrt{3}] \cup [\sqrt{3}, \infty)$ 55. -34 57. 4

59. Answers may vary. $\begin{vmatrix} L & -W \\ 2 & 2 \end{vmatrix}$ 61. Answers may vary. $\begin{vmatrix} a & b \\ -b & a \end{vmatrix}$ 63. Answers may vary. $\begin{vmatrix} 2\pi r & 2\pi r \\ -h & r \end{vmatrix}$

Exercise Set 9.7

1. (f) 3. (h) 5. (g) 7. (b)

9.

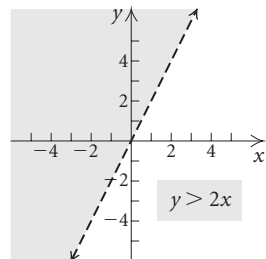

11.

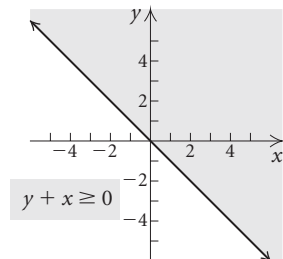

13.

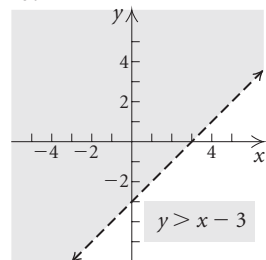

15.

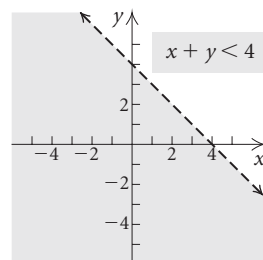

17.

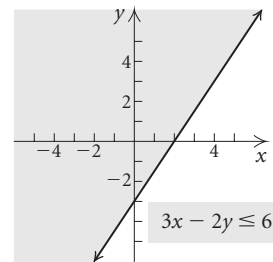

19.

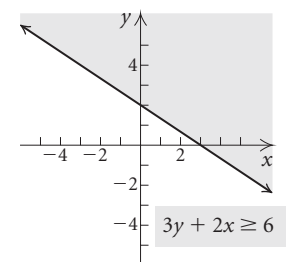

21.

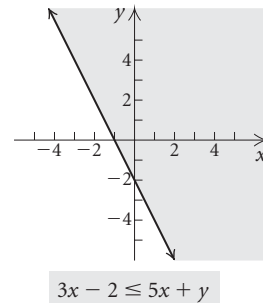

23.

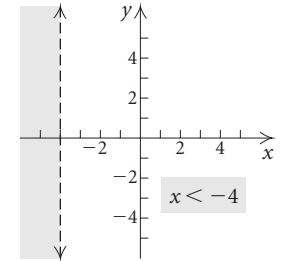

25.

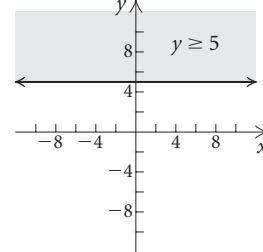

27.

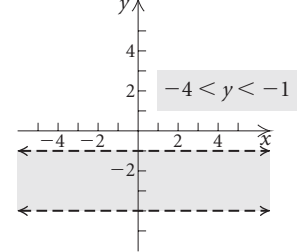

29.

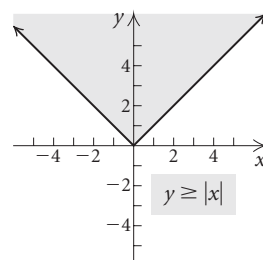

31. (f) 33. (a) 35. (b)

37. $y \leq -x + 4,$

$y \leq 3x$

39. $x < 2,$

$y > -1$

41. $y \leq -x + 3,$

$y \leq x + 1,$

$x \geq 0,$

$y \geq 0$

43.

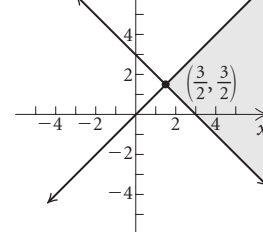

45.

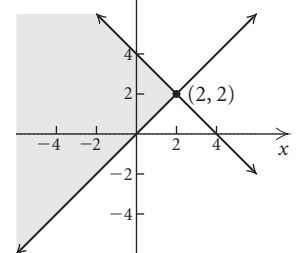

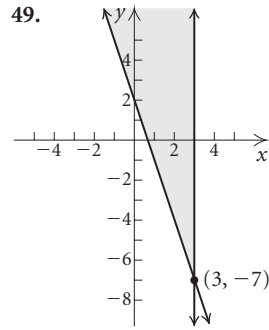
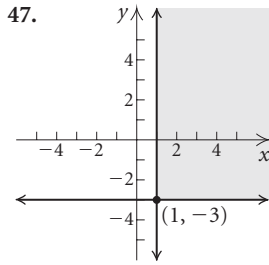

83. $[4.6]\{x \mid -1 \leq x \leq 3\}$, or $[-1, 3]$

84. $[4.6]\{x \mid -3 < x < -2\}$, or $(-3, -2)$

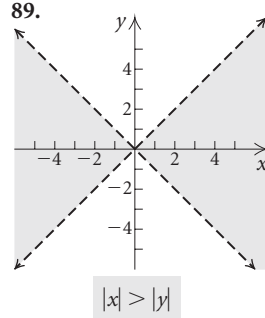
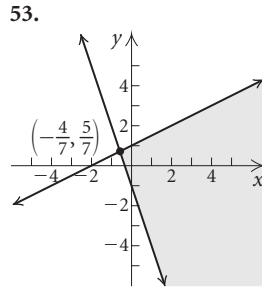
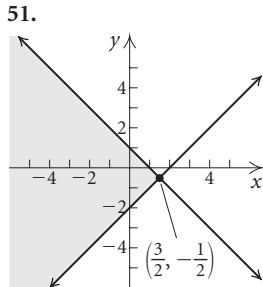
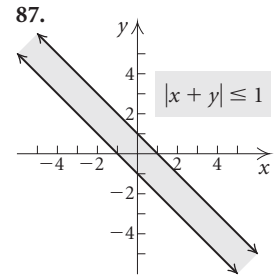
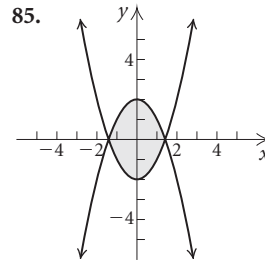

91. Maximum income of \$28,500 is achieved by making 30 less expensive assemblies and 30 more expensive assemblies.

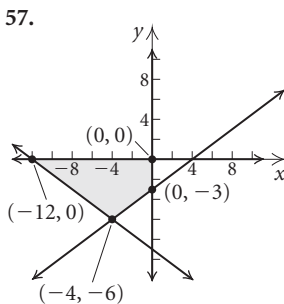
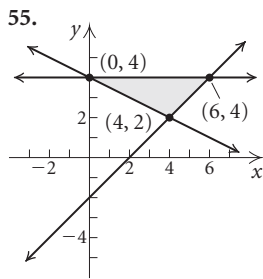

Exercise Set 9.8

1. $\frac{2}{x-3} - \frac{1}{x+2}$ 3. $\frac{5}{2x-1} - \frac{4}{3x-1}$

5. $\frac{2}{x+2} - \frac{3}{x-2} + \frac{4}{x+1}$

7. $-\frac{3}{(x+2)^2} - \frac{1}{x+2} + \frac{1}{x-1}$ 9. $\frac{3}{x-1} - \frac{4}{2x-1}$

11. $x - 2 + \frac{17/16}{x+1} - \frac{11/4}{(x+1)^2} - \frac{17/16}{x-3}$

13. $\frac{3x+5}{x^2+2} - \frac{4}{x-1}$ 15. $\frac{3}{2x-1} - \frac{2}{x+2} + \frac{10}{(x+2)^2}$

17. $3x + 1 + \frac{2}{2x-1} + \frac{3}{x+1}$

19. $-\frac{1}{x-3} + \frac{3x}{x^2+2x-5}$

21. $\frac{5}{3x+5} - \frac{3}{x+1} + \frac{4}{(x+1)^2}$ 23. $\frac{8}{4x-5} + \frac{3}{3x+2}$

25. $\frac{2x-5}{3x^2+1} - \frac{2}{x-2}$ 27. $[4.1], [4.3], [4.4] -1, \pm 3i$

28. $[4.1], [4.3], [4.4] 3, \pm i$ 29. $[4.4] -2, \frac{1 \pm \sqrt{5}}{2}$

30. $[4.4] -2, 3, \pm i$ 31. $[4.4] -3, -1 \pm \sqrt{2}$

33. $-\frac{1}{2a^2x} + \frac{1}{4a^2} + \frac{1}{4a^2}$

35. $-\frac{3}{25(\ln x + 2)} + \frac{3}{25(\ln x - 3)} + \frac{7}{5(\ln x - 3)^2}$

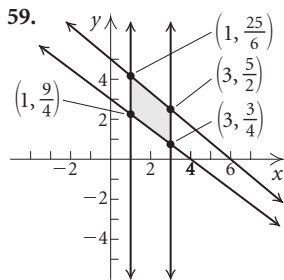

61. Maximum: 179 when $x = 7$ and $y = 0$; minimum: 48 when $x = 0$ and $y = 4$
 63. Maximum: 216 when $x = 0$ and $y = 6$; minimum: 0 when $x = 0$ and $y = 0$
 65. Maximum income of \$18 is achieved when 100 of each type of biscuit are made.

67. Maximum profit of \$11,000 is achieved by producing 100 units of lumber and 300 units of plywood.

69. Minimum cost of \$36 $\frac{12}{13}$ is achieved by using $1 \frac{11}{13}$ sacks of soybean meal and $1 \frac{11}{13}$ sacks of oats.

71. Maximum income of \$3110 is achieved when \$22,000 is invested in corporate bonds and \$18,000 is invested in municipal bonds.

73. Minimum cost of \$460 thousand is achieved using 30 P_1 's and 10 P_2 's.

75. Maximum profit per day of \$192 is achieved when 2 knit suits and 4 worsted suits are made.

77. Minimum weekly cost of \$19.05 is achieved when 1.5 lb of meat and 3 lb of cheese are used.

79. Maximum total number of 800 is achieved when there are 550 of A and 250 of B.

81. $[1.6]\{x \mid -7 \leq x < 2\}$, or $[-7, 2)$

82. $[3.5]\{x \mid x \leq 1 \text{ or } x \geq 5\}$, or $(-\infty, 1] \cup [5, \infty)$

Review Exercises: Chapter 9

1. True 2. False 3. True 4. False 5. (a) 6. (e)
 7. (h) 8. (d) 9. (b) 10. (g) 11. (c) 12. (f)
 13. $(-2, -2)$ 14. $(-5, 4)$ 15. No solution
 16. Infinitely many solutions; $(-y - 2, y)$ or $(x, -x - 2)$
 17. $(3, -1, -2)$ 18. No solution 19. $(-5, 13, 8, 2)$
 20. Consistent: 13, 14, 16, 17, 19; the others are inconsistent.
 21. Dependent: 16; the others are independent. 22. $(1, 2)$

23. $(-3, 4, -2)$ 24. Infinitely many solutions; $(\frac{z}{2}, -\frac{z}{2}, z)$
 25. $(-4, 1, -2, 3)$ 26. Nickels: 31; dimes: 44 27. 3%:
 \$1600; 3.5%: \$3400 28. 1 bagel, $\frac{1}{2}$ serving of cream cheese,
 2 bananas 29. 75, 69, 82 30. (a) $f(x) = -8x^2 + 16x + 40$;

(b) 16 thousand trademarks

31. $\begin{bmatrix} 0 & -1 & 6 \\ 3 & 1 & -2 \\ -2 & 1 & -2 \end{bmatrix}$ 32. $\begin{bmatrix} -3 & 3 & 0 \\ -6 & -9 & 6 \\ 6 & 0 & -3 \end{bmatrix}$

33. $\begin{bmatrix} -1 & 1 & 0 \\ -2 & -3 & 2 \\ 2 & 0 & -1 \end{bmatrix}$ 34. $\begin{bmatrix} -2 & 2 & 6 \\ 1 & -8 & 18 \\ 2 & 1 & -15 \end{bmatrix}$

35. Not defined 36. $\begin{bmatrix} 2 & -1 & -6 \\ 1 & 5 & -2 \\ -2 & -1 & 4 \end{bmatrix}$

37. $\begin{bmatrix} -13 & 1 & 6 \\ -3 & -7 & 4 \\ 8 & 3 & -5 \end{bmatrix}$ 38. $\begin{bmatrix} -2 & -1 & 18 \\ 5 & -3 & -2 \\ -2 & 3 & -8 \end{bmatrix}$

39. (a) $\begin{bmatrix} 0.98 & 0.23 & 0.30 & 0.28 & 0.45 \\ 1.03 & 0.19 & 0.27 & 0.34 & 0.41 \\ 1.01 & 0.21 & 0.35 & 0.31 & 0.39 \\ 0.99 & 0.25 & 0.29 & 0.33 & 0.42 \end{bmatrix}$;

(b) $[32 \ 19 \ 43 \ 38]$;

(c) $[131.98 \ 29.50 \ 40.80 \ 41.29 \ 54.92]$;

(d) the total cost, in dollars, for each item for the day's meals

40. $\begin{bmatrix} -\frac{1}{2} & 0 \\ \frac{1}{6} & \frac{1}{3} \end{bmatrix}$ 41. $\begin{bmatrix} 0 & 0 & \frac{1}{4} \\ 0 & -\frac{1}{2} & 0 \\ \frac{1}{3} & 0 & 0 \end{bmatrix}$

42. $\begin{bmatrix} 1 & 0 & 0 & 0 \\ 0 & \frac{1}{9} & \frac{5}{18} & 0 \\ 0 & -\frac{1}{9} & \frac{2}{9} & 0 \\ 0 & 0 & 0 & 1 \end{bmatrix}$ 43. $\begin{bmatrix} 3 & -2 & 4 \\ 1 & 5 & -3 \\ 2 & -3 & 7 \end{bmatrix} \begin{bmatrix} x \\ y \\ z \end{bmatrix} = \begin{bmatrix} 13 \\ 7 \\ -8 \end{bmatrix}$

44. $(-8, 7)$ 45. $(1, -2, 5)$ 46. $(2, -1, 1, -3)$
 47. 10 48. -18 49. -6 50. -1 51. $(3, -2)$
 52. $(-1, 5)$ 53. $(\frac{3}{2}, \frac{13}{14}, \frac{33}{14})$ 54. $(2, -1, 3)$

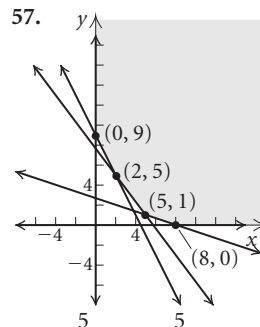
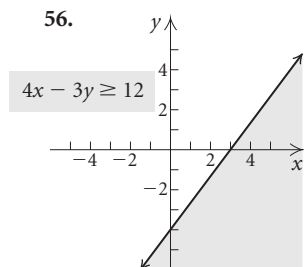
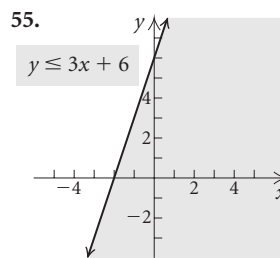

58. Minimum: 52 when $x = 2$ and $y = 4$; maximum: 92 when $x = 2$ and $y = 8$

59. Maximum score of 96 is achieved when 0 group A questions and 8 group B questions are answered.

60. $\frac{5}{x+1} - \frac{5}{x+2} - \frac{5}{(x+2)^2}$ 61. $\frac{2}{2x-3} - \frac{5}{x+4}$

62. C 63. A 64. B 65. 4%: \$10,000; 5%: \$12,000;
 5½%: \$18,000 66. $(\frac{5}{18}, \frac{1}{7})$ 67. $(1, \frac{1}{2}, \frac{1}{3})$

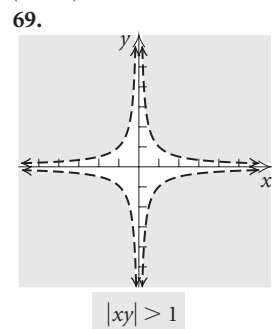
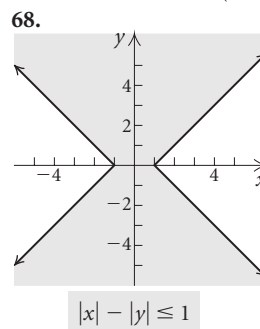

70. The solution of the equation $2x + 5 = 3x - 7$ is the first coordinate of the point of intersection of the graphs of $y_1 = 2x + 5$ and $y_2 = 3x - 7$. The solution of the system of equations $y = 2x + 5$, $y = 3x - 7$ is the ordered pair that is the point of intersection of y_1 and y_2 . 71. In general, $(\mathbf{AB})^2 \neq \mathbf{A}^2\mathbf{B}^2$. $(\mathbf{AB})^2 = \mathbf{ABAB}$ and $\mathbf{A}^2\mathbf{B}^2 = \mathbf{AABB}$.

Since matrix multiplication is not commutative, $\mathbf{BA} \neq \mathbf{AB}$, so $(\mathbf{AB})^2 \neq \mathbf{A}^2\mathbf{B}^2$.

72. If $\begin{vmatrix} a_1 & b_1 \\ a_2 & b_2 \end{vmatrix} = 0$, then $a_1 = ka_2$ and $b_1 = kb_2$ for some number k . This means that the equations $a_1x + b_1y = c_1$ and $a_2x + b_2y = c_2$ are dependent if $c_1 = kc_2$, or the system is inconsistent if $c_1 \neq kc_2$. 73. If $a_1x + b_1y = c_1$ and $a_2x + b_2y = c_2$ are parallel lines, then $a_1 = ka_2$, $b_1 = kb_2$, and $c_1 \neq kc_2$, for some number k .

Then $\begin{vmatrix} a_1 & b_1 \\ a_2 & b_2 \end{vmatrix} = 0$, $\begin{vmatrix} c_1 & b_1 \\ c_2 & b_2 \end{vmatrix} \neq 0$, and $\begin{vmatrix} a_1 & c_1 \\ a_2 & c_2 \end{vmatrix} \neq 0$.

74. The graph of a linear equation consists of a set of points on a line. The graph of a linear inequality consists of the set of points in a half-plane and might also include the points on the line that is the boundary of the half-plane.
 75. The denominator of the second fraction, $x^2 - 5x + 6$, can be factored into linear factors with real coefficients: $(x - 3)(x - 2)$. Thus the given expression is not a partial fraction decomposition.

Test: Chapter 9

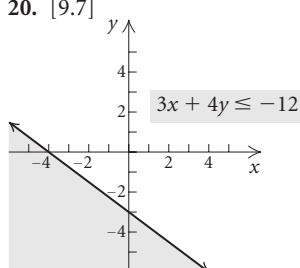
1. [9.1] $(-3, 5)$; consistent, independent
 2. [9.1] Infinitely many solutions; $(x, 2x - 3)$ or $(\frac{y + 3}{2}, y)$; consistent, dependent
 3. [9.1] No solution; inconsistent, independent
 4. [9.1] $(1, -2)$; consistent, independent
 5. [9.2] $(-1, 3, 2)$ 6. [9.1] Student: 342 tickets; nonstudent: 408 tickets 7. [9.2] Tricia: 120 orders; Maria: 104 orders; Antonio: 128 orders
 8. [9.4] $\begin{bmatrix} -2 & -3 \\ -3 & 4 \end{bmatrix}$
 9. [9.4] Not defined 10. [9.4] $\begin{bmatrix} -7 & -13 \\ 5 & -1 \end{bmatrix}$
 11. [9.4] Not defined 12. [9.4] $\begin{bmatrix} 2 & -2 & 6 \\ -4 & 10 & 4 \end{bmatrix}$
 13. [9.5] $\begin{bmatrix} 0 & -1 \\ -\frac{1}{4} & -\frac{3}{4} \end{bmatrix}$ 14. [9.4] (a) $\begin{bmatrix} 0.95 & 0.40 & 0.39 \\ 1.10 & 0.35 & 0.41 \\ 1.05 & 0.39 & 0.36 \end{bmatrix}$
 (b) $[26 \ 18 \ 23]$; (c) $[68.65 \ 25.67 \ 25.80]$; (d) the total cost, in dollars, for each type of menu item served on the given day
 15. [9.4] $\begin{bmatrix} 3 & -4 & 2 \\ 2 & 3 & 1 \\ 1 & -5 & -3 \end{bmatrix} \begin{bmatrix} x \\ y \\ z \end{bmatrix} = \begin{bmatrix} -8 \\ 7 \\ 3 \end{bmatrix}$
 16. [9.5] $(-2, 1, 1)$ 17. [9.6] 61 18. [9.6] -33
 19. [9.6] $(-\frac{1}{2}, \frac{3}{4})$
 20. [9.7]  $3x + 4y \leq -12$
 21. [9.7] Maximum: 15 when $x = 3$ and $y = 3$; minimum: 2 when $x = 1$ and $y = 0$
 22. [9.7] Maximum profit of \$375 occurs when 25 pound cakes and 75 carrot cakes are prepared.
 23. [9.8] $-\frac{2}{x-1} + \frac{5}{x+3}$ 24. [9.7] D
 25. [9.2] $A = 1, B = -3, C = 2$

Chapter 10

Exercise Set 10.1

1. (f) 3. (b) 5. (d)
 7. $V: (0, 0); F: (0, 5); D: y = -5$

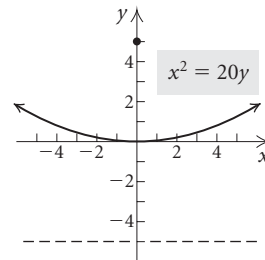

11. $V: (0, 0); F: (0, 1); D: y = -1$

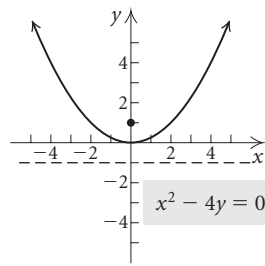

15. $y^2 = 16x$ 17. $x^2 = -4\pi y$

19. $(y - 2)^2 = 14(x + \frac{1}{2})$
 21. $V: (-2, 1); F: (-2, -\frac{1}{2}); D: y = \frac{5}{2}$

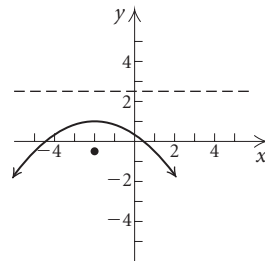

25. $V: (0, -2); F: (0, -1\frac{3}{4}); D: y = -2\frac{1}{4}$

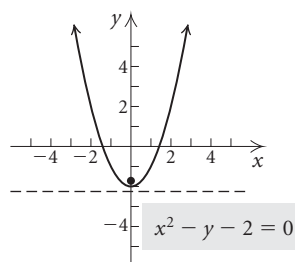

9. $V: (0, 0); F: (-\frac{3}{2}, 0); D: x = \frac{3}{2}$

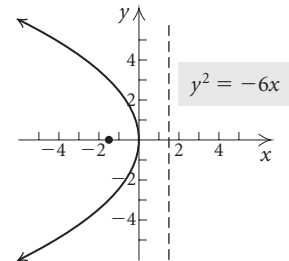

13. $V: (0, 0); F: (\frac{1}{8}, 0); D: x = -\frac{1}{8}$

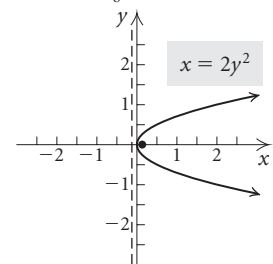

23. $V: (-1, -3); F: (-1, -\frac{7}{2}); D: y = -\frac{5}{2}$

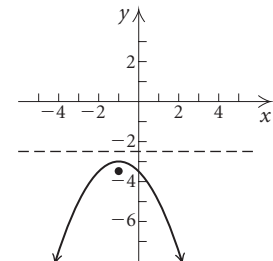

27. $V: (-2, -1); F: (-2, -\frac{3}{4}); D: y = -1\frac{1}{4}$

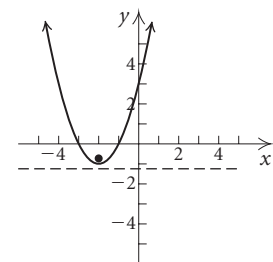

$y = x^2 + 4x + 3$

29. $V: (5\frac{3}{4}, \frac{1}{2}); F: (6, \frac{1}{2}); D: x = 5\frac{1}{2}$

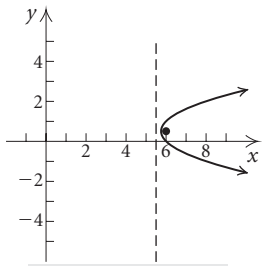

$$y^2 - y - x + 6 = 0$$

31. (a) $y^2 = 16x$; (b) $3\frac{33}{64}$ ft
 33. $\frac{2}{3}$ ft or 8 in. 35. [1.1] (h)
 36. [1.1], [1.4] (d)
 37. [1.3] (a), (b), (f), (g)
 38. [1.3] (b) 39. [1.3] (b)
 40. [1.1] (f)
 41. [1.4] (a) and (g)
 42. [1.4] (a) and (h); (g) and (h); (b) and (c)

43. $(x + 1)^2 = -4(y - 2)$

45. 10 ft, 11.6 ft, 16.4 ft, 24.4 ft, 35.6 ft, 50 ft

Exercise Set 10.2

1. (b) 3. (d) 5. (a)

7. (7, -2); 8

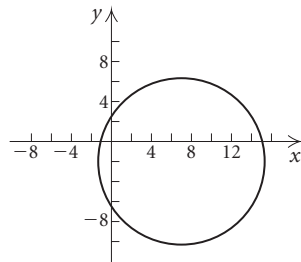

$$x^2 + y^2 - 14x + 4y = 11$$

9. (-3, 1); 4

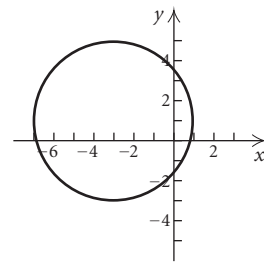

$$x^2 + y^2 + 6x - 2y = 6$$

11. (-2, 3); 5

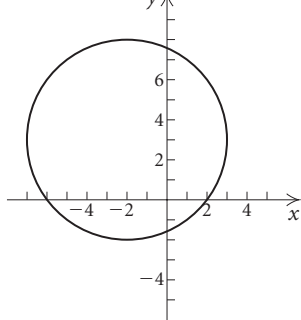

$$x^2 + y^2 + 4x - 6y - 12 = 0$$

13. (3, 4); 3

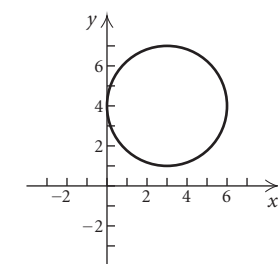

$$x^2 + y^2 - 6x - 8y + 16 = 0$$

15. (-3, 5); $\sqrt{34}$

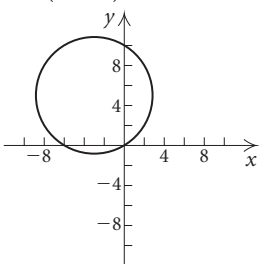

$$x^2 + y^2 + 6x - 10y = 0$$

17. $(\frac{9}{2}, -2)$; $\frac{5\sqrt{5}}{2}$

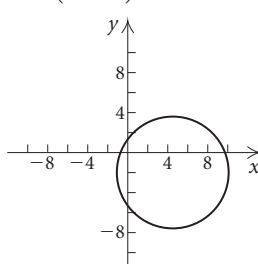

$$x^2 + y^2 - 9x = 7 - 4y$$

19. (c) 21. (d)

23. $V: (2, 0), (-2, 0); F: (\sqrt{3}, 0), (-\sqrt{3}, 0)$

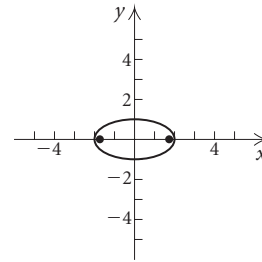

$$\frac{x^2}{4} + \frac{y^2}{1} = 1$$

27. $V: (-\sqrt{3}, 0), (\sqrt{3}, 0); F: (-1, 0), (1, 0)$

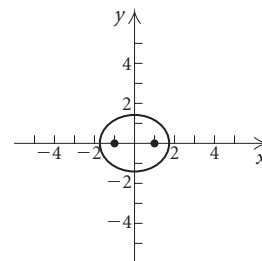

$$2x^2 + 3y^2 = 6$$

25. $V: (0, 4), (0, -4); F: (0, \sqrt{7}), (0, -\sqrt{7})$

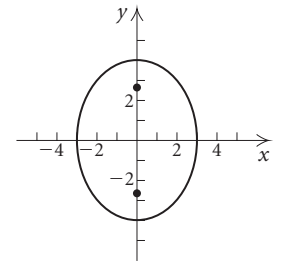

$$16x^2 + 9y^2 = 144$$

29. $V: (-\frac{1}{2}, 0), (\frac{1}{2}, 0); F: (-\frac{\sqrt{5}}{6}, 0), (\frac{\sqrt{5}}{6}, 0)$

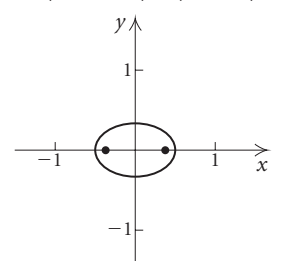

$$4x^2 + 9y^2 = 1$$

31. $\frac{x^2}{49} + \frac{y^2}{40} = 1$ 33. $\frac{x^2}{25} + \frac{y^2}{64} = 1$ 35. $\frac{x^2}{9} + \frac{y^2}{5} = 1$

37. $C: (1, 2); V: (4, 2), (-2, 2); F: (1 + \sqrt{5}, 2), (1 - \sqrt{5}, 2)$

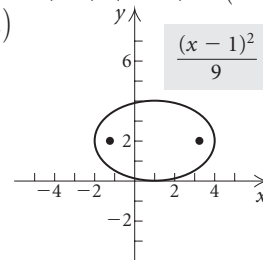

$$\frac{(x-1)^2}{9} + \frac{(y-2)^2}{4} = 1$$

39. $C: (-3, 5); V: (-3, 11), (-3, -1); F: (-3, 5 + \sqrt{11}), (-3, 5 - \sqrt{11})$

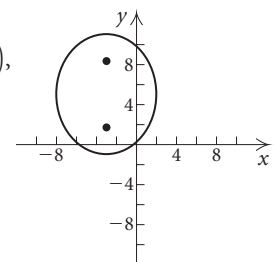

$$\frac{(x+3)^2}{25} + \frac{(y-5)^2}{36} = 1$$

41. C: $(-2, 1)$; V: $(-10, 1), (6, 1)$;
F: $(-6, 1), (2, 1)$

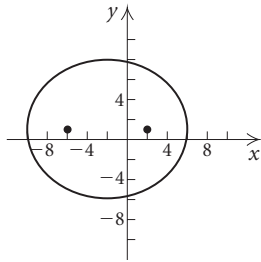

$$3(x + 2)^2 + 4(y - 1)^2 = 192$$

43. C: $(2, -1)$; V: $(-1, -1), (5, -1)$; F: $(2 + \sqrt{5}, -1), (2 - \sqrt{5}, -1)$

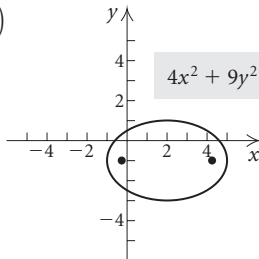

$$4x^2 + 9y^2 - 16x + 18y - 11 = 0$$

45. C: $(1, 1)$; V: $(1, 3), (1, -1)$;
F: $(1, 1 + \sqrt{3}), (1, 1 - \sqrt{3})$

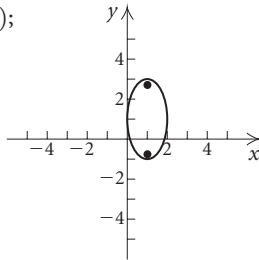

$$4x^2 + y^2 - 8x - 2y + 1 = 0$$

47. Example 2; $\frac{3}{5} < \frac{\sqrt{12}}{4}$ 49. $\frac{x^2}{15} + \frac{y^2}{16} = 1$

51. $\frac{x^2}{2500} + \frac{y^2}{144} = 1$ 53. 2×10^6 mi

55. [1.1] Midpoint 56. [1.5] Zero 57. [1.1] y -intercept
58. [3.2] Two different real-number solutions
59. [4.3] Remainder 60. [10.2] Ellipse 61. [10.1] Parabola

62. [10.2] Circle 63. $\frac{(x - 3)^2}{4} + \frac{(y - 1)^2}{25} = 1$

65. $\frac{x^2}{9} + \frac{y^2}{484/5} = 1$ 67. About 9.1 ft

Exercise Set 10.3

1. (b) 3. (c) 5. (a) 7. $\frac{y^2}{9} - \frac{x^2}{16} = 1$

9. $\frac{x^2}{4} - \frac{y^2}{9} = 1$

11. C: $(0, 0)$; V: $(2, 0), (-2, 0)$;
F: $(2\sqrt{2}, 0), (-2\sqrt{2}, 0)$;
A: $y = x, y = -x$

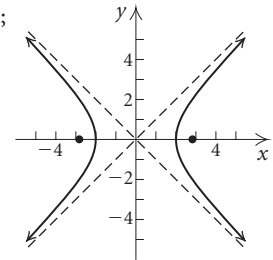

$$\frac{x^2}{4} - \frac{y^2}{4} = 1$$

13. C: $(2, -5)$; V: $(-1, -5), (5, -5)$;
F: $(2 - \sqrt{10}, -5), (2 + \sqrt{10}, -5)$;

- A: $y = -\frac{x}{3} - \frac{13}{3}, y = \frac{x}{3} - \frac{17}{3}$

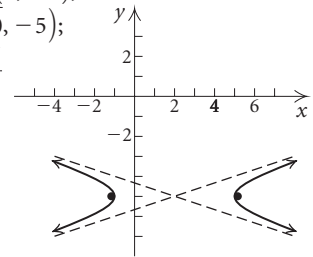

$$\frac{(x - 2)^2}{9} - \frac{(y + 5)^2}{1} = 1$$

15. C: $(-1, -3)$; V: $(-1, -1), (-1, -5)$;
F: $(-1, -3 + 2\sqrt{5}), (-1, -3 - 2\sqrt{5})$;

- A: $y = \frac{1}{2}x - \frac{5}{2}, y = -\frac{1}{2}x - \frac{7}{2}$

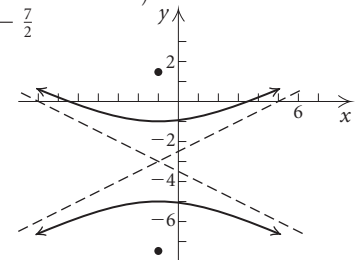

$$\frac{(y + 3)^2}{4} - \frac{(x + 1)^2}{16} = 1$$

17. C: $(0, 0)$; V: $(-2, 0), (2, 0)$; F: $(-\sqrt{5}, 0), (\sqrt{5}, 0)$;
A: $y = -\frac{1}{2}x, y = \frac{1}{2}x$

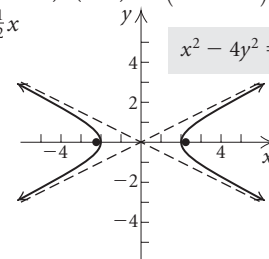

$$x^2 - 4y^2 = 4$$

19. C: $(0, 0)$; V: $(0, -3), (0, 3)$; F: $(0, -3\sqrt{10}), (0, 3\sqrt{10})$;
A: $y = \frac{1}{3}x, y = -\frac{1}{3}x$

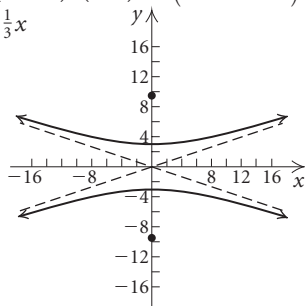

$$9y^2 - x^2 = 81$$

21. C: $(0, 0)$; V: $(-\sqrt{2}, 0), (\sqrt{2}, 0)$; F: $(-2, 0), (2, 0)$;
A: $y = x, y = -x$

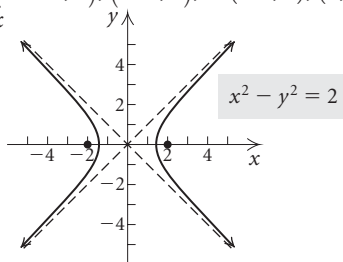

$$x^2 - y^2 = 2$$

23. C: $(0, 0)$; V: $(0, -\frac{1}{2}), (0, \frac{1}{2})$; F: $(0, -\frac{\sqrt{2}}{2}), (0, \frac{\sqrt{2}}{2})$;
A: $y = x, y = -x$

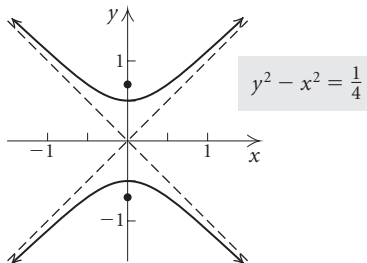

$$y^2 - x^2 = \frac{1}{4}$$

25. C: $(1, -2)$; V: $(0, -2), (2, -2)$; F: $(1 - \sqrt{2}, -2), (1 + \sqrt{2}, -2)$;
A: $y = -x - 1, y = x - 3$

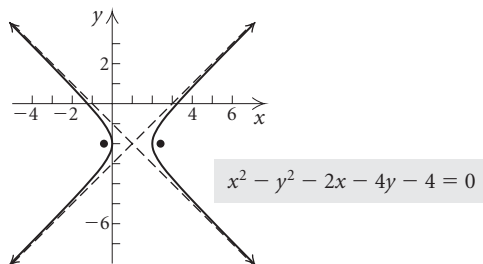

$$x^2 - y^2 - 2x - 4y - 4 = 0$$

27. C: $(\frac{1}{3}, 3)$; V: $(-\frac{2}{3}, 3), (\frac{4}{3}, 3)$; F: $(\frac{1}{3} - \sqrt{37}, 3), (\frac{1}{3} + \sqrt{37}, 3)$;
A: $y = 6x + 1, y = -6x + 5$

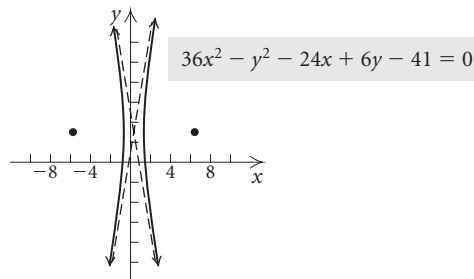

$$36x^2 - y^2 - 24x + 6y - 41 = 0$$

29. C: $(3, 1)$; V: $(3, 3), (3, -1)$; F: $(3, 1 + \sqrt{13}), (3, 1 - \sqrt{13})$;
A: $y = \frac{2}{3}x - 1, y = -\frac{2}{3}x + 3$

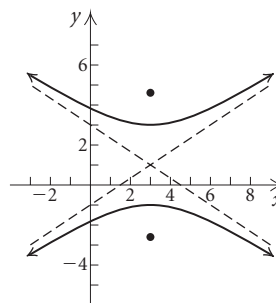

$$9y^2 - 4x^2 - 18y + 24x - 63 = 0$$

31. C: $(1, -2)$; V: $(2, -2), (0, -2)$;
F: $(1 + \sqrt{2}, -2), (1 - \sqrt{2}, -2)$;
A: $y = x - 3, y = -x - 1$

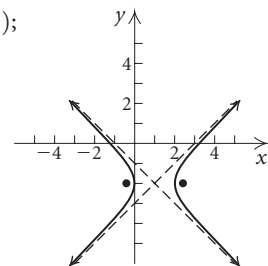

$$x^2 - y^2 - 2x - 4y = 4$$

33. C: $(-3, 4)$; V: $(-3, 10), (-3, -2)$;
F: $(-3, 4 + 6\sqrt{2}), (-3, 4 - 6\sqrt{2})$;
A: $y = x + 7, y = -x + 1$

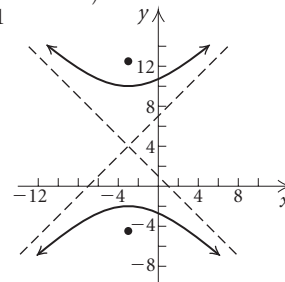

$$y^2 - x^2 - 6x - 8y - 29 = 0$$

35. Example 3; $\frac{\sqrt{5}}{1} > \frac{5}{4}$ 37. $\frac{x^2}{9} - \frac{(y-7)^2}{16} = 1$
 39. $\frac{y^2}{25} - \frac{x^2}{11} = 1$ 41. [5.1] (a) Yes; (b) $f^{-1}(x) = \frac{x+3}{2}$
 42. [5.1] (a) Yes; (b) $f^{-1}(x) = \sqrt[3]{x-2}$
 43. [5.1] (a) Yes; (b) $f^{-1}(x) = \frac{5}{x} + 1$, or $\frac{5+x}{x}$
 44. [5.1] (a) Yes; (b) $f^{-1}(x) = x^2 - 4, x \geq 0$
 45. [9.1], [9.3], [9.5], [9.6] (6, -1) 46. [9.1], [9.3], [9.5], [9.6] (1, -1) 47. [9.1], [9.3], [9.5], [9.6] (2, -1)
 48. [9.1], [9.3], [9.5], [9.6] (-3, 4)
 49. $\frac{(y+5)^2}{9} - (x-3)^2 = 1$ 51. $\frac{x^2}{345.96} - \frac{y^2}{22,154.04} = 1$

Visualizing the Graph

1. B 2. J 3. F 4. I 5. H 6. G 7. E
 8. D 9. C 10. A

Exercise Set 10.4

1. (e) 3. (c) 5. (b) 7. (-4, -3), (3, 4)
 9. (0, 2), (3, 0) 11. (-5, 0), (4, 3), (4, -3)
 13. (3, 0), (-3, 0) 15. (0, -3), (4, 5) 17. (-2, 1)
 19. (3, 4), (-3, -4), (4, 3), (-4, -3)
 21. $\left(\frac{6\sqrt{21}}{7}, \frac{4i\sqrt{35}}{7}\right), \left(\frac{6\sqrt{21}}{7}, -\frac{4i\sqrt{35}}{7}\right),$
 $\left(-\frac{6\sqrt{21}}{7}, \frac{4i\sqrt{35}}{7}\right), \left(-\frac{6\sqrt{21}}{7}, -\frac{4i\sqrt{35}}{7}\right)$
 23. (3, 2), $\left(4, \frac{3}{2}\right)$
 25. $\left(\frac{5+\sqrt{70}}{3}, \frac{-1+\sqrt{70}}{3}\right), \left(\frac{5-\sqrt{70}}{3}, \frac{-1-\sqrt{70}}{3}\right)$
 27. $(\sqrt{2}, \sqrt{14}), (-\sqrt{2}, \sqrt{14}), (\sqrt{2}, -\sqrt{14}),$
 $(-\sqrt{2}, -\sqrt{14})$ 29. (1, 2), (-1, -2), (2, 1), (-2, -1)
 31. $\left(\frac{15+\sqrt{561}}{8}, \frac{11-3\sqrt{561}}{8}\right), \left(\frac{15-\sqrt{561}}{8}, \frac{11+3\sqrt{561}}{8}\right)$
 33. $\left(\frac{7-\sqrt{33}}{2}, \frac{7+\sqrt{33}}{2}\right), \left(\frac{7+\sqrt{33}}{2}, \frac{7-\sqrt{33}}{2}\right)$
 35. (3, 2), (-3, -2), (2, 3), (-2, -3)
 37. $\left(\frac{5-9\sqrt{15}}{20}, \frac{-45+3\sqrt{15}}{20}\right), \left(\frac{5+9\sqrt{15}}{20}, \frac{-45-3\sqrt{15}}{20}\right)$
 39. (3, -5), (-1, 3) 41. (8, 5), (-5, -8) 43. (3, 2),
 (-3, -2) 45. (2, 1), (-2, -1), (1, 2), (-1, -2)
 47. $\left(4 + \frac{3i\sqrt{6}}{2}, -4 + \frac{3i\sqrt{6}}{2}\right), \left(4 - \frac{3i\sqrt{6}}{2}, -4 - \frac{3i\sqrt{6}}{2}\right)$
 49. $(3, \sqrt{5}), (-3, -\sqrt{5}), (\sqrt{5}, 3), (-\sqrt{5}, -3)$
 51. $\left(\frac{8\sqrt{5}}{5}i, \frac{3\sqrt{105}}{5}\right), \left(\frac{8\sqrt{5}}{5}i, -\frac{3\sqrt{105}}{5}\right),$
 $\left(-\frac{8\sqrt{5}}{5}i, \frac{3\sqrt{105}}{5}\right), \left(-\frac{8\sqrt{5}}{5}i, -\frac{3\sqrt{105}}{5}\right)$

53. (2, 1), (-2, -1), $\left(-i\sqrt{5}, \frac{2i\sqrt{5}}{5}\right), \left(i\sqrt{5}, -\frac{2i\sqrt{5}}{5}\right)$
 55. True 57. True 59. 6 cm by 8 cm 61. 4 in. by 5 in.
 63. 30 yd by 75 yd 65. Length: $\sqrt{3}$ m; width: 1 m
 67. 16 ft, 24 ft 69. (b) 71. (d) 73. (a)
 75.

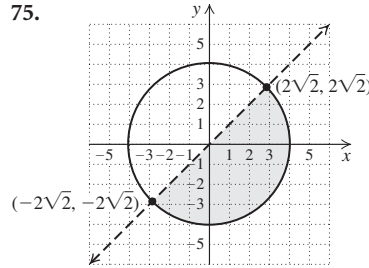

77.

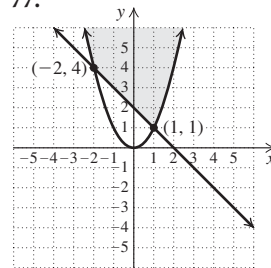

79.

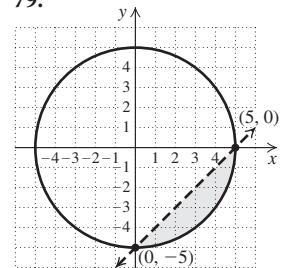

81.

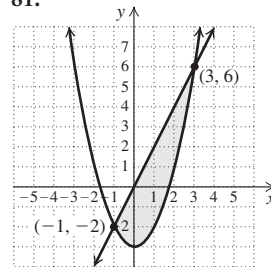

83.

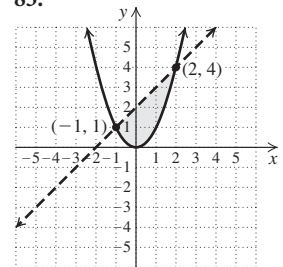

85. [5.5] 2 86. [5.5] 2.048 87. [5.5] 81 88. [5.5] 5

89. $(x-2)^2 + (y-3)^2 = 1$ 91. $\frac{x^2}{4} + y^2 = 1$

93. $(x-1)^2 + (y-2)^2 = 25$

95. There is no number x such that $\frac{x^2}{a^2} - \left(\frac{b}{a}x\right)^2 = 1$,

because the left side simplifies to $\frac{x^2}{a^2} - \frac{x^2}{a^2}$, which is 0.

97. $\left(\frac{1}{2}, \frac{1}{4}\right), \left(\frac{1}{2}, -\frac{1}{4}\right), \left(-\frac{1}{2}, \frac{1}{4}\right), \left(-\frac{1}{2}, -\frac{1}{4}\right)$

99. Factor: $x^3 + y^3 = (x+y)(x^2 - xy + y^2)$. We know that $x + y = 1$, so $(x+y)^2 = x^2 + 2xy + y^2 = 1$, or $x^2 + y^2 = 1 - 2xy$. We also know that $xy = 1$, so $x^2 + y^2 = 1 - 2 \cdot 1 = -1$. Then $x^3 + y^3 = 1 \cdot (-1 - 1) = -2$.

101. (2, 4), (4, 2)

103. (3, -2), (-3, 2), (2, -3), (-2, 3)

105. $\left(\frac{2 \log 3 + 3 \log 5}{3(\log 3 \cdot \log 5)}, \frac{4 \log 3 - 3 \log 5}{3(\log 3 \cdot \log 5)}\right)$

Mid-Chapter Mixed Review: Chapter 10

1. True 2. False 3. True 4. False 5. (b)
 6. (e) 7. (d) 8. (a) 9. (g) 10. (f)
 11. (h) 12. (c)
 13. V: (0, 0); F: (3, 0);
 D: $x = -3$

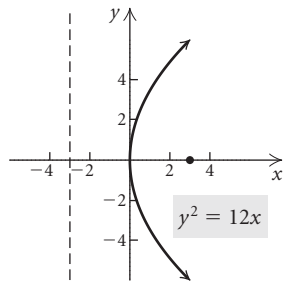

15. (-2, 4); 5

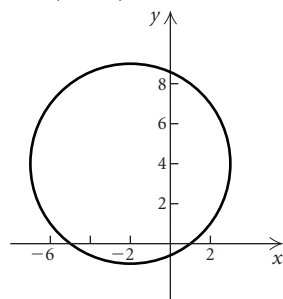

17. V: (0, -3), (0, 3);
 F: (0, -2√2), (0, 2√2)

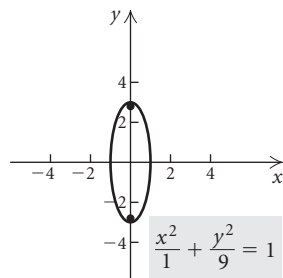

14. V: (3, 2); F: (3, 3);
 D: $y = 1$

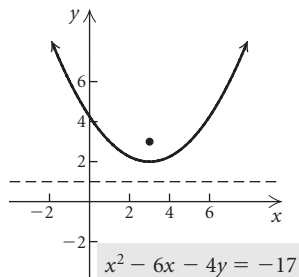

16. (3, -1); 4

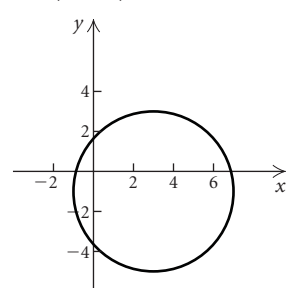

18. V: (1, -6), (1, 4);
 F: (1, -1 - √21),
 (1, -1 + √21)

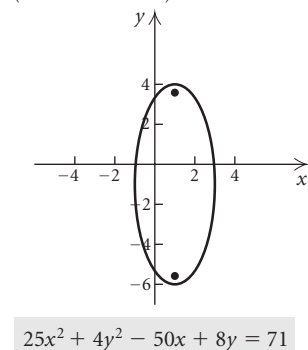

19. C: (0, 0); V: (0, -4), (0, 4); F: (0, -5), (0, 5);
 A: $y = -\frac{4}{3}x, y = \frac{4}{3}x$

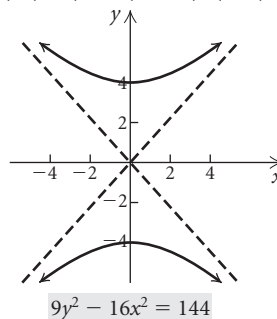

20. C: (-3, 2); V: (-4, 2), (-2, 2);
 F: (-3 - √5, 2), (-3 + √5, 2);
 A: $y - 2 = 2(x + 3), y - 2 = -2(x + 3)$

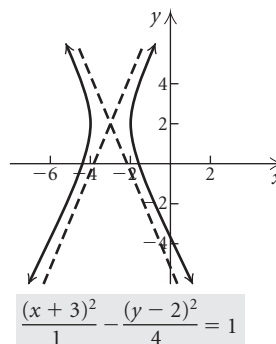

21. (-2, -5), (5, 2) 22. (2, 2), (-2, -2)
 23. (2i√3, 4), (2i√3, -4); (-2i√3, 4), (-2i√3, -4)
 24. (-1/3, 10/3), (-1, 2)
 25. -2 and 3

26.

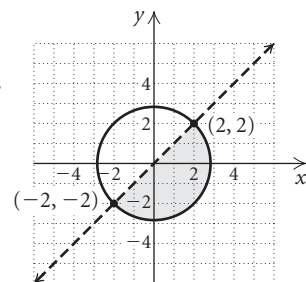

27.

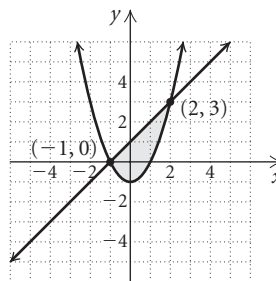

28. No; parabolas with a horizontal axis of symmetry fail the vertical-line test. 29. No; the center of an ellipse is not part of the graph of the ellipse. Its coordinates do not satisfy the equation of the ellipse.

30. No; the asymptotes of a hyperbola are not part of the graph of the hyperbola. The coordinates of points on the asymptotes do not satisfy the equation of the hyperbola.
 31. Although we can always visualize the real-number solutions, we cannot visualize the imaginary-number solutions.

Exercise Set 10.5

1. $(0, -2)$ 3. $(1, \sqrt{3})$ 5. $(\sqrt{2}, 0)$ 7. $(\sqrt{3}, 1)$
 9. Ellipse or circle 11. Hyperbola 13. Parabola
 15. Hyperbola 17. Ellipse or circle
 19.

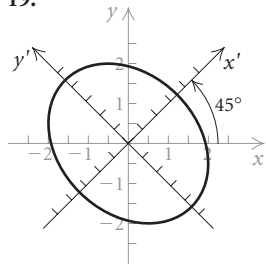

$$\frac{(x')^2}{3} + \frac{(y')^2}{5} = 1$$

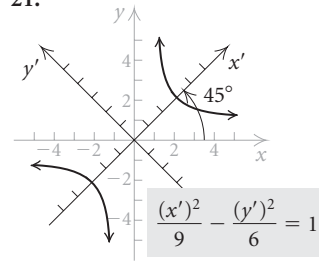

$$\frac{(x')^2}{9} - \frac{(y')^2}{6} = 1$$

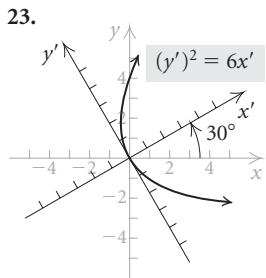

$$(y')^2 = 6x'$$

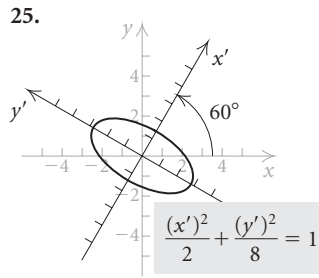

$$\frac{(x')^2}{2} + \frac{(y')^2}{8} = 1$$

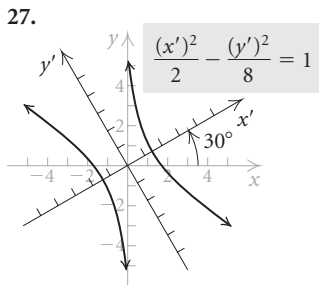

$$\frac{(x')^2}{2} - \frac{(y')^2}{8} = 1$$

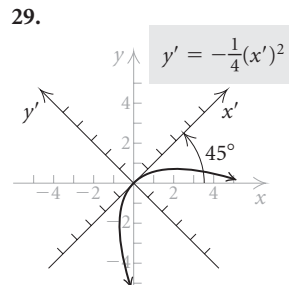

$$y' = -\frac{1}{4}(x')^2$$

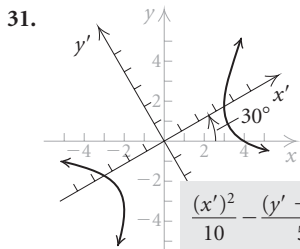

$$\frac{(x')^2}{10} - \frac{(y' + 1)^2}{5} = 1$$

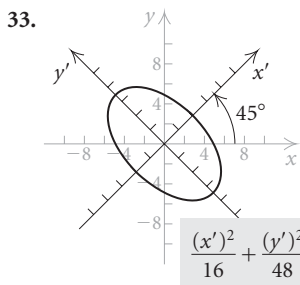

$$\frac{(x')^2}{16} + \frac{(y')^2}{48} = 1$$

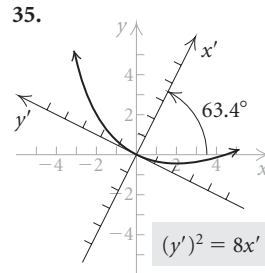

$$(y')^2 = 8x'$$

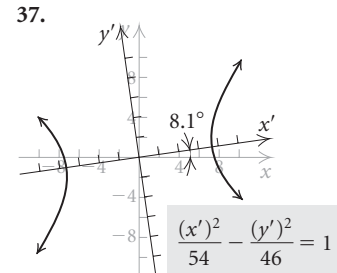

$$\frac{(x')^2}{54} - \frac{(y')^2}{46} = 1$$

35. [9.4] $\frac{2\pi}{3}$ 40. [9.4] $-\frac{7\pi}{4}$ 41. [9.4] 60°
 42. [9.4] 135° 43. $x = x' \cos \theta - y' \sin \theta, y = x' \sin \theta + y' \cos \theta$
 45. $A' + C' = A \cos^2 \theta + B \sin \theta \cos \theta + C \sin^2 \theta$
 $+ A \sin^2 \theta - B \sin \theta \cos \theta + C \cos^2 \theta$
 $= A(\sin^2 \theta + \cos^2 \theta) + C(\sin^2 \theta + \cos^2 \theta)$
 $= A + C$

Exercise Set 10.6

1. (b) 3. (a) 5. (d)
 7. (a) Parabola; (b) vertical, 1 unit to the right of the pole;
 (c) $(\frac{1}{2}, 0)$; (d)

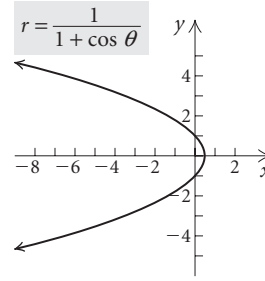

9. (a) Hyperbola; (b) horizontal, $\frac{3}{2}$ units below the pole;
 (c) $(-3, \frac{\pi}{2}), (1, \frac{3\pi}{2})$; (d)

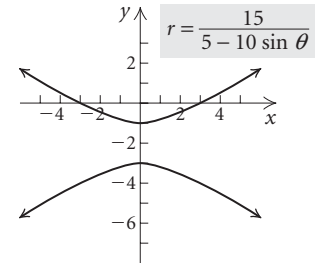

11. (a) Ellipse; (b) vertical, $\frac{8}{3}$ units to the left of the pole;
 (c) $(\frac{8}{3}, 0), (\frac{8}{9}, \pi)$; (d)

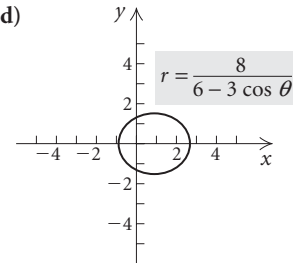

13. (a) Hyperbola; (b) horizontal, $\frac{4}{3}$ units above the pole;

(c) $(\frac{4}{5}, \frac{\pi}{2}), (-4, \frac{3\pi}{2})$; (d)

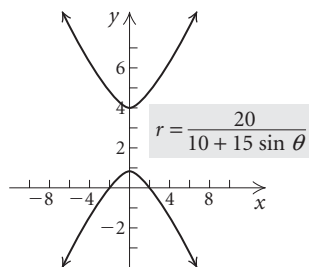

15. (a) Ellipse; (b) vertical, 3 units to the right of the pole;

(c) (1, 0), (3, π); (d)

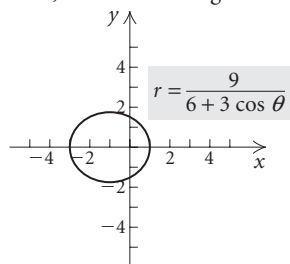

17. (a) Parabola; (b) horizontal, $\frac{3}{2}$ units below the pole;

(c) $(\frac{3}{4}, \frac{3\pi}{2})$; (d)

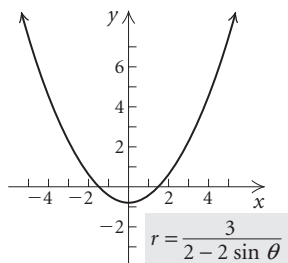

19. (a) Ellipse; (b) vertical, 4 units to the left of the pole;

(c) (4, 0), $(\frac{4}{3}, \pi)$; (d)

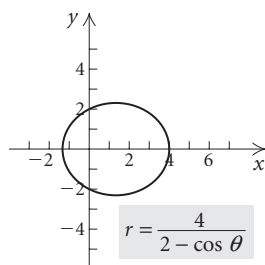

21. (a) Hyperbola; (b) horizontal, $\frac{7}{10}$ units above the pole;

(c) $(\frac{7}{12}, \frac{\pi}{2}), (-\frac{7}{8}, \frac{3\pi}{2})$; (d)

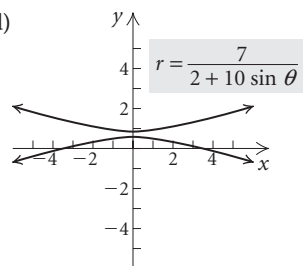

23. $y^2 + 2x - 1 = 0$ 25. $x^2 - 3y^2 - 12y - 9 = 0$

27. $27x^2 + 36y^2 - 48x - 64 = 0$

29. $4x^2 - 5y^2 + 24y - 16 = 0$

31. $3x^2 + 4y^2 + 6x - 9 = 0$ 33. $4x^2 - 12y - 9 = 0$

35. $3x^2 + 4y^2 - 8x - 16 = 0$

37. $4x^2 - 96y^2 + 140y - 49 = 0$ 39. $r = \frac{6}{1 + 2 \sin \theta}$

41. $r = \frac{4}{1 + \cos \theta}$ 43. $r = \frac{2}{2 - \cos \theta}$

45. $r = \frac{15}{4 + 3 \sin \theta}$ 47. $r = \frac{8}{1 - 4 \sin \theta}$

49. [1.2] $f(t) = (t - 3)^2 + 4$, or $t^2 - 6t + 13$

50. [1.2] $f(2t) = (2t - 3)^2 + 4$, or $4t^2 - 12t + 13$

51. [1.2] $f(t - 1) = (t - 4)^2 + 4$, or $t^2 - 8t + 20$

52. [1.2] $f(t + 2) = (t - 1)^2 + 4$, or $t^2 - 2t + 5$

53. $r = \frac{1.5 \times 10^8}{1 + \sin \theta}$

Exercise Set 10.7

1.

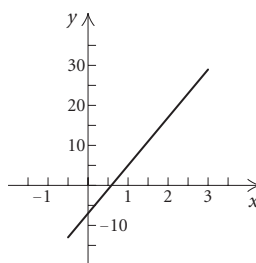

$x = \frac{1}{2}t, y = 6t - 7; -1 \leq t \leq 6$

$y = 12x - 7, -\frac{1}{2} \leq x \leq 3$

3.

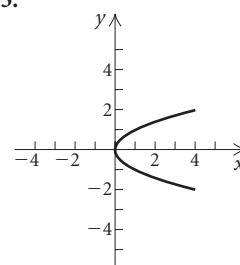

$x = 4t^2, y = 2t; -1 \leq t \leq 1$

$x = y^2, 0 \leq x \leq 4$

5. $x = y^4, 0 \leq x \leq 16$ 7. $y = \frac{1}{x}, 1 \leq x \leq 5$

9. $y = \frac{1}{4}(x + 1)^2, -7 \leq x \leq 5$ 11. $y = \frac{1}{x}, x > 0$

13. $x^2 + y^2 = 9, -3 \leq x \leq 3$

15. $x^2 + \frac{y^2}{4} = 1, -1 \leq x \leq 1$ 17. $y = \frac{1}{x}, x \geq 1$

19. $(x - 1)^2 + (y - 2)^2 = 4, -1 \leq x \leq 3$

21. Answers may vary. $x = t, y = 4t - 3; x = \frac{t}{4} + 3,$

$y = t + 9$ 23. Answers may vary. $x = t,$
 $y = (t - 2)^2 - 6t; x = t + 2, y = t^2 - 6t - 12$

25. (a) $x = 40\sqrt{3}t, y = 7 + 40t - 16t^2$; (b) 31 ft, 23 ft;

(c) about 2.7 sec; (d) about 187.1 ft; (e) 32 ft

27. [1.1]

28. [1.1]

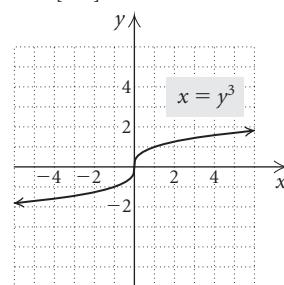
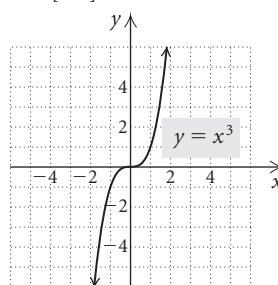

29. [1.2]

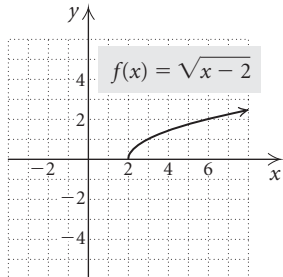

30. [4.5]

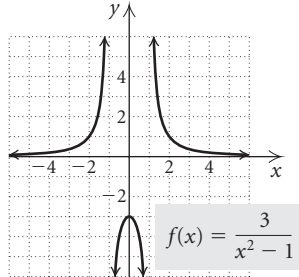

31. $x = 3 \cos t, y = -3 \sin t$

Review Exercises: Chapter 10

1. True 2. False 3. False 4. True 5. False
 6. (d) 7. (a) 8. (e) 9. (g) 10. (b) 11. (f)
 12. (h) 13. (c) 14. $x^2 = -6y$ 15. $F: (-3, 0)$;
 $V: (0, 0)$; $D: x = 3$ 16. $V: (-5, 8)$; $F: (-5, \frac{13}{2})$; $D: y = \frac{17}{2}$
 17. $C: (2, -1)$; $V: (-3, -1), (7, -1)$; $F: (-1, -1), (5, -1)$

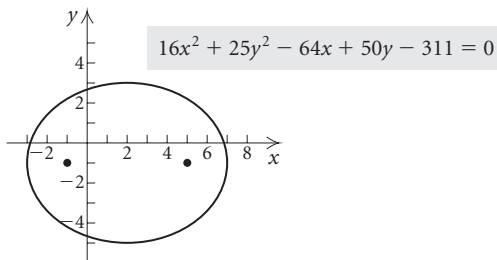

18. $\frac{x^2}{9} + \frac{y^2}{16} = 1$

19. $C: (-2, \frac{1}{4})$; $V: (0, \frac{1}{4}), (-4, \frac{1}{4})$;
 $F: (-2 + \sqrt{6}, \frac{1}{4}), (-2 - \sqrt{6}, \frac{1}{4})$;

$A: y - \frac{1}{4} = \frac{\sqrt{2}}{2}(x + 2), y - \frac{1}{4} = -\frac{\sqrt{2}}{2}(x + 2)$

20. 0.167 ft 21. $(-8\sqrt{2}, 8), (8\sqrt{2}, 8)$

22. $(3, \frac{\sqrt{29}}{2}), (-3, \frac{\sqrt{29}}{2}), (3, -\frac{\sqrt{29}}{2}),$

$(-3, -\frac{\sqrt{29}}{2})$ 23. (7, 4) 24. (2, 2), $(\frac{32}{9}, -\frac{10}{9})$

25. (0, -3), (2, 1) 26. (4, 3), (4, -3), (-4, 3), (-4, -3)

27. $(-\sqrt{3}, 0), (\sqrt{3}, 0), (-2, 1), (2, 1)$ 28. $(-\frac{3}{5}, \frac{21}{5}),$
 (3, -3) 29. (6, 8), (6, -8), (-6, 8), (-6, -8)

30. (2, 2), (-2, -2), $(2\sqrt{2}, \sqrt{2}), (-2\sqrt{2}, -\sqrt{2})$

31. 7, 4 32. 7 m by 12 m 33. 4, 8 34. 32 cm, 20 cm

35. 11 ft, 3 ft

36.

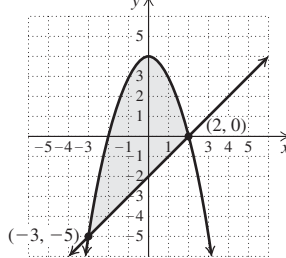

37.

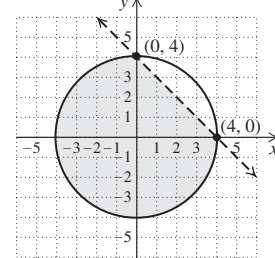

38.

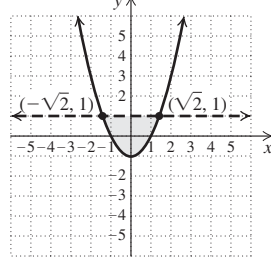

39.

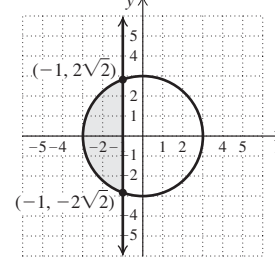

40.

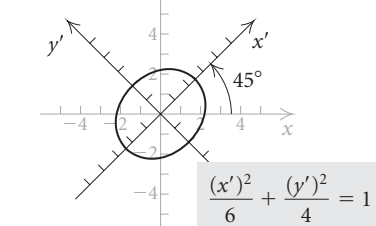

41.

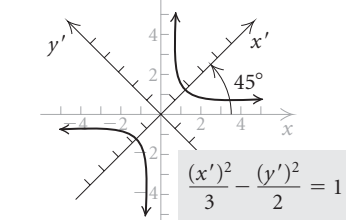

42.

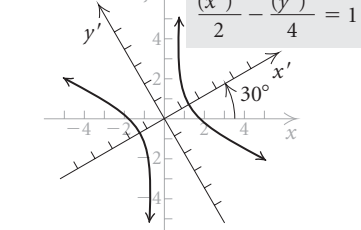

43.

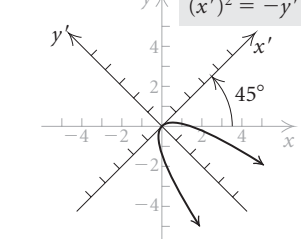

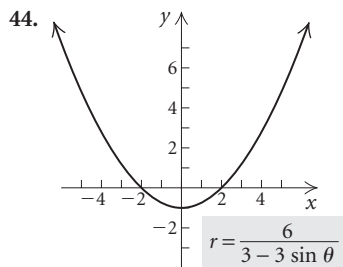

Horizontal directrix 2 units below the pole; vertex: $(1, \frac{3\pi}{2})$

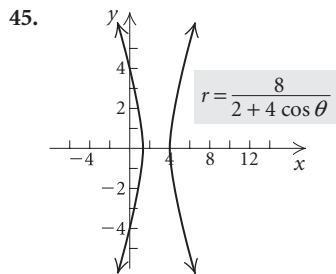

Vertical directrix 2 units to the right of the pole; vertices: $(\frac{4}{3}, 0), (-4, \pi)$

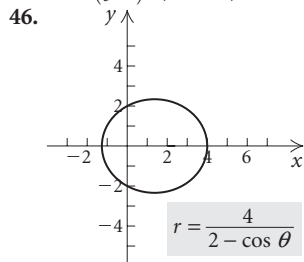

Vertical directrix 4 units to the left of the pole; vertices: $(4, 0), (\frac{4}{3}, \pi)$

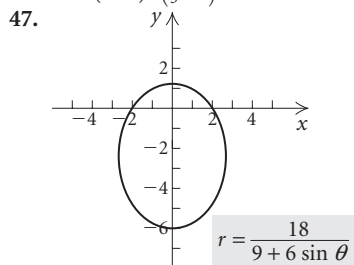

Horizontal directrix 3 units above the pole;

vertices: $(\frac{6}{5}, \frac{\pi}{2}), (6, \frac{3\pi}{2})$ 48. $x^2 - 4y - 4 = 0$

49. $3x^2 - y^2 - 16x + 16 = 0$

50. $3x^2 + 4y^2 - 8x - 16 = 0$

51. $9x^2 + 5y^2 + 24y - 36 = 0$

52. $r = \frac{1}{1 + \frac{1}{2} \cos \theta}$, or $r = \frac{2}{2 + \cos \theta}$ 53. $r = \frac{18}{1 - 3 \sin \theta}$

54. $r = \frac{4}{1 - \cos \theta}$ 55. $r = \frac{6}{1 + 2 \sin \theta}$

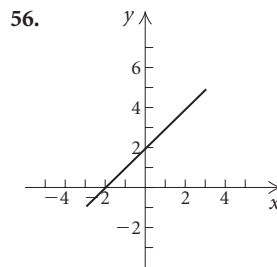

$x = t, y = 2 + t; -3 \leq t \leq 3$

$y = 2 + x, -3 \leq x \leq 3$

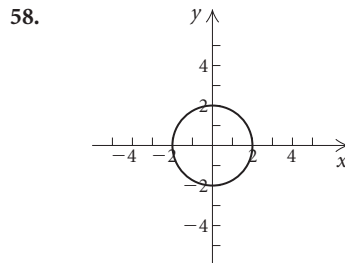

$x = 2 \cos t, y = 2 \sin t; 0 \leq t \leq 2\pi$

$x^2 + y^2 = 4$

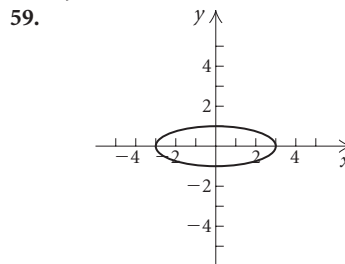

$x = 3 \sin t, y = \cos t; 0 \leq t \leq 2\pi$ $\frac{x^2}{9} + y^2 = 1$

60. Answers may vary. $x = t, y = 2t - 3; x = t + 1, y = 2t - 1$ 61. Answers may vary. $x = t, y = t^2 + 4;$

$x = t - 2, y = t^2 - 4t + 8$ 62. (a) $x = 75\sqrt{2}t, y = 75\sqrt{2}t - 16t^2;$ (b) 174.2 ft, 60.4 ft; (c) about 6.6 sec;

(d) about 700.0 ft; (e) about 175.8 ft 63. B 64. D

65. C 66. $\frac{8}{7}, \frac{7}{2}$ 67. $(x - 2)^2 + (y - 1)^2 = 100$

68. $x^2 + \frac{y^2}{9} = 1$ 69. $\frac{x^2}{778.41} - \frac{y^2}{39,221.59} = 1$

70. See p. 833 in the text. 71. Circles and ellipses are not functions. 72. The procedure for rotation of axes would be done first when $B \neq 0$. Then we would proceed as when $B = 0$.

73. Each graph is an ellipse. The value of e determines the location of the center and the lengths of the major and minor axes. The larger the value of e , the farther the center is from the pole and the longer the axes.

Test: Chapter 10

1. [10.3] (c) 2. [10.1] (b) 3. [10.2] (a) 4. [10.2] (d)
 5. [10.1] V: (0, 0); F: (0, 3); D: $y = -3$
 6. [10.1] V: (-1, -1); F: (1, -1); D: $x = -3$

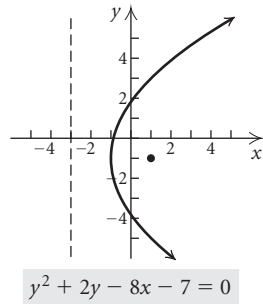
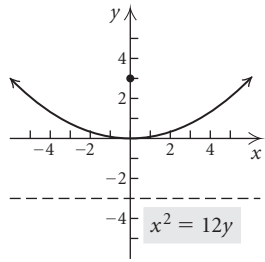

7. [10.1] $x^2 = 8y$
 8. [10.2] Center: (-1, 3); radius: 5

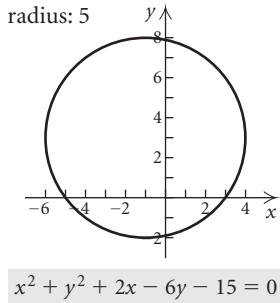

9. [10.2] C: (0, 0); V: (-4, 0), (4, 0); F: $(-\sqrt{7}, 0), (\sqrt{7}, 0)$

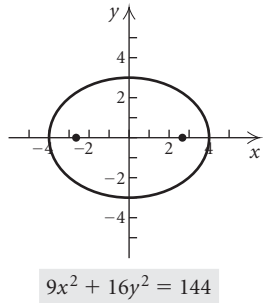

10. [10.2] C: (-1, 2); V: (-1, -1), (-1, 5); F: $(-1, 2 - \sqrt{5}), (-1, 2 + \sqrt{5})$

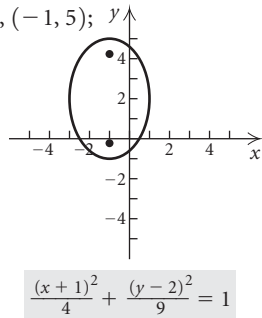

11. [10.2] $\frac{x^2}{4} + \frac{y^2}{25} = 1$

12. [10.3] C: (0, 0); V: (-1, 0), (1, 0); F: $(-\sqrt{5}, 0), (\sqrt{5}, 0)$
 A: $y = -2x, y = 2x$

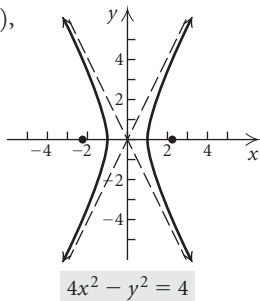

13. [10.3] C: (-1, 2); V: (-1, 0), (-1, 4); F: $(-1, 2 - \sqrt{13}), (-1, 2 + \sqrt{13})$
 A: $y = -\frac{2}{3}x + \frac{4}{3}, y = \frac{2}{3}x + \frac{8}{3}$

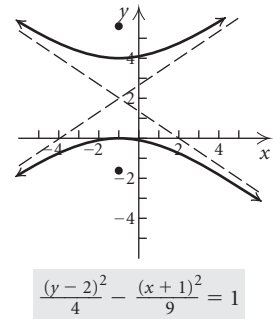

14. [10.3] $y = \frac{\sqrt{2}}{2}x, y = -\frac{\sqrt{2}}{2}x$ 15. [10.1] $\frac{27}{8}$ in.

16. [10.4] (1, 2), (1, -2), (-1, 2), (-1, -2)
 17. [10.4] (3, -2), (-2, 3) 18. [10.4] (2, 3), (3, 2)
 19. [10.4] 5 ft by 4 ft 20. [10.4] 60 ft by 45 ft

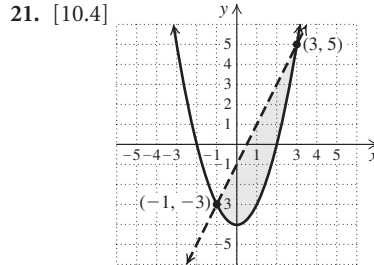

21. [10.4]
 22. [10.5] After using the rotation of axes formulas with $\theta = 45^\circ$, we have $\frac{(x')^2}{9} + (y')^2 = 1$.

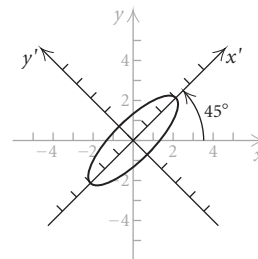

23. [10.6]

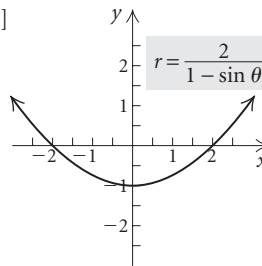

Horizontal directrix 2 units below the pole; vertex: $(1, \frac{3\pi}{2})$

24. [10.6] $r = \frac{6}{1 + 2 \cos \theta}$

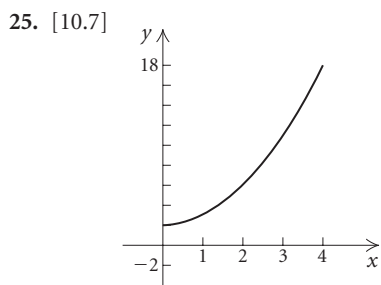

$x = \sqrt{t}, y = t + 2; 0 \leq t \leq 16$

26. [10.7] $x^2 + y^2 = 9, -3 \leq x \leq 3$ 27. [10.7] Answers may vary. $x = t, y = t - 5; x = t + 5, y = t$
 28. [10.7] (a) $x = 125\sqrt{3}t, y = 10 + 125t - 16t^2$;
 (b) 119 ft, 241 ft; (c) about 7.9 sec; (d) about 1710.4 ft;
 (e) about 254.1 ft 29. [10.1] A
 30. [10.2] $(x - 3)^2 + (y + 1)^2 = 8$

Chapter 11

Exercise Set 11.1

1. 3, 7, 11, 15; 39; 59 3. $2, \frac{3}{2}, \frac{4}{3}, \frac{5}{4}, \frac{10}{9}, \frac{15}{14}$ 5. $0, \frac{3}{5}, \frac{4}{5}, \frac{15}{17}, \frac{99}{101}, \frac{112}{113}$
 7. -1, 4, -9, 16; 100; -225 9. 7, 3, 7, 3; 3; 7 11. 34
 13. 225 15. -33,880 17. 67 19. $2n$
 21. $(-1)^n \cdot 2 \cdot 3^{n-1}$ 23. $\frac{n+1}{n+2}$ 25. $n(n+1)$
 27. $\log 10^{n-1}$, or $n - 1$ 29. 6; 28 31. 20; 30
 33. $\frac{1}{2} + \frac{1}{4} + \frac{1}{6} + \frac{1}{8} + \frac{1}{10} = \frac{137}{120}$ 35. $1 + 2 + 4 + 8 + 16 + 32 + 64 = 127$ 37. $\ln 7 + \ln 8 + \ln 9 + \ln 10 = \ln(7 \cdot 8 \cdot 9 \cdot 10) = \ln 5040 \approx 8.5252$ 39. $\frac{1}{2} + \frac{2}{3} + \frac{3}{4} + \frac{4}{5} + \frac{5}{6} + \frac{6}{7} + \frac{7}{8} + \frac{8}{9} = \frac{15,551}{2520}$ 41. $-1 + 1 - 1 + 1 - 1 = -1$
 43. $3 - 6 + 9 - 12 + 15 - 18 + 21 - 24 = -12$
 45. $2 + 1 + \frac{2}{5} + \frac{1}{5} + \frac{2}{17} + \frac{1}{13} + \frac{2}{37} = \frac{157,351}{40,885}$
 47. $3 + 2 + 3 + 6 + 11 + 18 = 43$ 49. $\frac{1}{2} + \frac{2}{3} + \frac{4}{5} + \frac{8}{9} + \frac{16}{17} + \frac{32}{33} + \frac{64}{65} + \frac{128}{129} + \frac{256}{257} + \frac{512}{513} + \frac{1024}{1025} \approx 9.736$
 51. $\sum_{k=1}^{\infty} 5k$ 53. $\sum_{k=1}^6 (-1)^{k+1} 2^k$ 55. $\sum_{k=1}^6 (-1)^k \frac{k}{k+1}$
 57. $\sum_{k=2}^n (-1)^k k^2$ 59. $\sum_{k=1}^{\infty} \frac{1}{k(k+1)}$ 61. $4, 1\frac{1}{4}, 1\frac{4}{5}, 1\frac{5}{9}$
 63. 6561, -81, 9i, $-3\sqrt{i}$ 65. 2, 3, 5, 8 67. (a) 1062, 1127.84, 1197.77, 1272.03, 1350.90, 1434.65, 1523.60, 1618.07, 1718.39, 1824.93; (b) \$3330.35 69. 1, 2, 4, 8, 16, 32, 64, 128, 256, 512, 1024, 2048, 4096, 8192, 16,384, 32,768, 65,536
 71. 1, 1, 2, 3, 5, 8, 13 72. [9.1], [9.3], [9.5], [9.6] (-1, -3)
 73. [9.1], [9.3], [9.5], [9.6] 2008: 9.5 million visitors; 2009: 8.6 million visitors 74. [10.2] (3, -2); 4
 75. [10.2] $\left(-\frac{5}{2}, 4\right); \frac{\sqrt{97}}{2}$ 77. $i, -1, -i, 1, i; i$
 79. $\ln(1 \cdot 2 \cdot 3 \cdots n)$

Exercise Set 11.2

1. $a_1 = 3, d = 5$ 3. $a_1 = 9, d = -4$ 5. $a_1 = \frac{3}{2}, d = \frac{3}{4}$
 7. $a_1 = \$316, d = -\3 9. $a_{12} = 46$ 11. $a_{14} = -\frac{17}{3}$
 13. $a_{10} = \$7941.62$ 15. 33rd 17. 46th 19. $a_1 = 5$
 21. $n = 39$ 23. $a_1 = \frac{1}{3}, d = \frac{1}{2}, \frac{1}{3}, \frac{5}{6}, \frac{4}{3}, \frac{11}{6}, \frac{7}{3}$ 25. 670
 27. 160,400 29. 735 31. 990 33. 1760 35. $\frac{65}{2}$
 37. $-\frac{6026}{13}$ 39. 1260 poles 41. 4960¢, or \$49.60
 43. Yes; 32; 1600 ft 45. 3 plants; 171 plants 47. Yes; 3
 48. [9.1], [9.3], [9.5], [9.6] (2, 5) 49. [9.2], [9.3], [9.5], [9.6] (2, -1, 3) 50. [10.2] (-4, 0), (4, 0); $(-\sqrt{7}, 0)$, $(\sqrt{7}, 0)$ 51. [10.2] $\frac{x^2}{4} + \frac{y^2}{25} = 1$ 53. n^2
 55. $a_1 = 60 - 5p - 5q; d = 5p + 2q - 20$ 57. 6, 8, 10
 59. $5\frac{4}{5}, 7\frac{3}{5}, 9\frac{2}{5}, 11\frac{1}{5}$ 61. Insert 16 arithmetic means between 1 and 50 with $d = \frac{49}{17}$.
 63. $m = p + d$
 $m = q - d$
 $2m = p + q$ Adding
 $m = \frac{p + q}{2}$

Visualizing the Graph

1. J 2. A 3. C 4. G 5. F 6. H 7. E
 8. D 9. B 10. I

Exercise Set 11.3

1. 2 3. -1 5. -2 7. 0.1 9. $\frac{a}{2}$ 11. 128
 13. 162 15. $7(5)^{40}$ 17. 3^{n-1} 19. $(-1)^{n-1}$ 21. $\frac{1}{x^n}$
 23. 762 25. $\frac{4921}{18}$ 27. True 29. True 31. True
 33. 8 35. 125 37. Does not exist 39. $\frac{2}{3}$
 41. $29\frac{38,569}{59,049}$ 43. 2 45. Does not exist 47. \$4545.45
 49. $\frac{160}{9}$ 51. $\frac{13}{99}$ 53. 9 55. $\frac{34,091}{9990}$ 57. \$2,684,354.55
 59. (a) About 297 ft; (b) 300 ft 61. \$23,841.50
 63. \$523,619.17 65. \$86,666,666,667
 67. [2.3] $(f \circ g)(x) = 16x^2 + 40x + 25$;
 $(g \circ f)(x) = 4x^2 + 5$ 68. [2.3] $(f \circ g)(x) = x^2 + x + 2$;
 $(g \circ f)(x) = x^2 - x + 3$ 69. [5.5] 2.209 70. [5.5] $\frac{1}{16}$
 71. $(4 - \sqrt{6})/(\sqrt{3} - \sqrt{2}) = 2\sqrt{3} + \sqrt{2}$,
 $(6\sqrt{3} - 2\sqrt{2})/(4 - \sqrt{6}) = 2\sqrt{3} + \sqrt{2}$; there exists
 a common ratio, $2\sqrt{3} + \sqrt{2}$; thus the sequence is geometric.
 73. (a) $\frac{13}{3}, \frac{22}{3}, \frac{34}{3}, \frac{46}{3}, \frac{58}{3}$; (b) $-\frac{11}{3}, -\frac{2}{3}, \frac{10}{3}, -\frac{50}{3}, \frac{250}{3}$ or 5; 8, 12,
 18, 27 75. $S_n = \frac{x^2(1 - (-x)^n)}{x + 1}$ 77. $\frac{a_{n+1}}{a_n} = r$, so
 $\ln \frac{a_{n+1}}{a_n} = \ln r$. But $\ln \frac{a_{n+1}}{a_n} = \ln a_{n+1} - \ln a_n = \ln r$. Thus,
 $\ln a_1, \ln a_2, \dots$ is an arithmetic sequence with common
 difference $\ln r$. 79. 512 cm²

Exercise Set 11.4

1. $1^2 < 1^3$, false; $2^2 < 2^3$, true; $3^2 < 3^3$, true; $4^2 < 4^3$, true;
 $5^2 < 5^3$, true 3. A polygon of 3 sides has $\frac{3(3-3)}{2}$

diagonals. True; A polygon of 4 sides has $\frac{4(4-3)}{2}$ diagonals.

True; A polygon of 5 sides has $\frac{5(5-3)}{2}$ diagonals. True;

A polygon of 6 sides has $\frac{6(6-3)}{2}$ diagonals. True; A polygon

of 7 sides has $\frac{7(7-3)}{2}$ diagonals. True.

5. $S_n: 2 + 4 + 6 + \dots + 2n = n(n + 1)$

$S_1: 2 = 1(1 + 1)$

$S_k: 2 + 4 + 6 + \dots + 2k = k(k + 1)$

$S_{k+1}: 2 + 4 + 6 + \dots + 2k + 2(k + 1)$
 $= (k + 1)(k + 2)$

(1) *Basis step:* S_1 true by substitution.

(2) *Induction step:* Assume S_k . Deduce S_{k+1} .

Starting with the left side of S_{k+1} , we have

$2 + 4 + 6 + \dots + 2k + 2(k + 1)$

$= k(k + 1) + 2(k + 1)$ **By S_k**

$= (k + 1)(k + 2)$ **Distributive law**

7. $S_n: 1 + 5 + 9 + \dots + (4n - 3) = n(2n - 1)$

$S_1: 1 = 1(2 \cdot 1 - 1)$

$S_k: 1 + 5 + 9 + \dots + (4k - 3) = k(2k - 1)$

$S_{k+1}: 1 + 5 + 9 + \dots + (4k - 3) + [4(k + 1) - 3]$
 $= (k + 1)[2(k + 1) - 1]$
 $= (k + 1)(2k + 1)$

(1) *Basis step:* S_1 true by substitution.

(2) *Induction step:* Assume S_k . Deduce S_{k+1} .

Starting with the left side of S_{k+1} , we have

$1 + 5 + 9 + \dots + (4k - 3) + [4(k + 1) - 3]$

$= k(2k - 1) + [4(k + 1) - 3]$ **By S_k**

$= 2k^2 - k + 4k + 4 - 3$

$= 2k^2 + 3k + 1$

$= (k + 1)(2k + 1)$.

9. $S_n: 2 + 4 + 8 + \dots + 2^n = 2(2^n - 1)$

$S_1: 2 = 2(2 - 1)$

$S_k: 2 + 4 + 8 + \dots + 2^k = 2(2^k - 1)$

$S_{k+1}: 2 + 4 + 8 + \dots + 2^k + 2^{k+1} = 2(2^{k+1} - 1)$

(1) *Basis step:* S_1 is true by substitution.

(2) *Induction step:* Assume S_k . Deduce S_{k+1} .

Starting with the left side of S_{k+1} , we have

$2 + 4 + 8 + \dots + 2^k + 2^{k+1}$

$= \underbrace{2(2^k - 1)}_{2^{k+1} - 2} + 2^{k+1}$ **By S_k**

$= 2^{k+1} - 2 + 2^{k+1}$

$= 2 \cdot 2^{k+1} - 2$

$= 2(2^{k+1} - 1)$.

11. $S_n: n < n + 1$

$S_1: 1 < 1 + 1$

$S_k: k < k + 1$

$S_{k+1}: k + 1 < (k + 1) + 1$

(1) *Basis step:* Since $1 < 1 + 1$, S_1 is true.

(2) *Induction step:* Assume S_k . Deduce S_{k+1} . Now

$k < k + 1$

By S_k

$k + 1 < k + 1 + 1$

Adding 1

$k + 1 < k + 2$.

Simplifying

13. $S_n: 2n \leq 2^n$

$S_1: 2 \cdot 1 \leq 2^1$

$S_k: 2k \leq 2^k$

$S_{k+1}: 2(k + 1) \leq 2^{k+1}$

(1) *Basis step:* Since $2 = 2$, S_1 is true.

(2) *Induction step:* Let k be any natural number.

Assume S_k . Deduce S_{k+1} .

$2k \leq 2^k$

By S_k

$2 \cdot 2k \leq 2 \cdot 2^k$

Multiplying by 2

$4k \leq 2^{k+1}$

Since $1 \leq k$, $k + 1 \leq k + k$, or $k + 1 \leq 2k$.

Then $2(k + 1) \leq 4k$. **Multiplying by 2**

Thus, $2(k + 1) \leq 4k \leq 2^{k+1}$, so $2(k + 1) \leq 2^{k+1}$.

15.

$S_n: \frac{1}{1 \cdot 2 \cdot 3} + \frac{1}{2 \cdot 3 \cdot 4} + \frac{1}{3 \cdot 4 \cdot 5} + \dots$
 $+ \frac{1}{n(n+1)(n+2)} = \frac{n(n+3)}{4(n+1)(n+2)}$

$S_1: \frac{1}{1 \cdot 2 \cdot 3} = \frac{1(1+3)}{4(1+1)(1+2)}$

$S_k: \frac{1}{1 \cdot 2 \cdot 3} + \frac{1}{2 \cdot 3 \cdot 4} + \dots + \frac{1}{k(k+1)(k+2)}$
 $= \frac{k(k+3)}{4(k+1)(k+2)}$

$S_{k+1}: \frac{1}{1 \cdot 2 \cdot 3} + \frac{1}{2 \cdot 3 \cdot 4} + \dots + \frac{1}{k(k+1)(k+2)}$
 $+ \frac{1}{(k+1)(k+2)(k+3)}$
 $= \frac{(k+1)(k+4)}{4(k+1+1)(k+1+2)} = \frac{(k+1)(k+4)}{4(k+2)(k+3)}$

(1) *Basis step:* Since $\frac{1}{1 \cdot 2 \cdot 3} = \frac{1}{6}$ and

$\frac{1(1+3)}{4(1+1)(1+2)} = \frac{1 \cdot 4}{4 \cdot 2 \cdot 3} = \frac{1}{6}$, S_1 is true.

(2) *Induction step:* Assume S_k . Deduce S_{k+1} .

Add $\frac{1}{(k+1)(k+2)(k+3)}$ on both sides of S_k and

simplify the right side. Only the right side is shown here.

$\frac{k(k+3)}{4(k+1)(k+2)} + \frac{1}{(k+1)(k+2)(k+3)}$
 $= \frac{k(k+3)(k+3) + 4}{4(k+1)(k+2)(k+3)}$
 $= \frac{k^3 + 6k^2 + 9k + 4}{4(k+1)(k+2)(k+3)}$
 $= \frac{(k+1)^2(k+4)}{4(k+1)(k+2)(k+3)}$
 $= \frac{(k+1)(k+4)}{4(k+2)(k+3)}$

17.

$$S_n: 1 + 2 + 3 + \cdots + n = \frac{n(n+1)}{2}$$

$$S_1: 1 = \frac{1(1+1)}{2}$$

$$S_k: 1 + 2 + 3 + \cdots + k = \frac{k(k+1)}{2}$$

$$S_{k+1}: 1 + 2 + 3 + \cdots + k + (k+1) = \frac{(k+1)(k+2)}{2}$$

 (1) *Basis step:* S_1 true by substitution.

 (2) *Induction step:* Assume S_k . Deduce S_{k+1} . Starting with the left side of S_{k+1} , we have

$$\begin{aligned} & \underbrace{1 + 2 + 3 + \cdots + k + (k+1)} \\ &= \frac{k(k+1)}{2} + (k+1) \quad \text{By } S_k \\ &= \frac{k(k+1) + 2(k+1)}{2} \quad \text{Adding} \\ &= \frac{(k+1)(k+2)}{2}. \quad \text{Distributive law} \end{aligned}$$

$$19. S_n: 1^3 + 2^3 + 3^3 + \cdots + n^3 = \frac{n^2(n+1)^2}{4}$$

$$S_1: 1^3 = \frac{1^2(1+1)^2}{4}$$

$$S_k: 1^3 + 2^3 + 3^3 + \cdots + k^3 = \frac{k^2(k+1)^2}{4}$$

$$S_{k+1}: 1^3 + 2^3 + 3^3 + \cdots + k^3 + (k+1)^3 = \frac{(k+1)^2[(k+1)+1]^2}{4}$$

 (1) *Basis step:* $S_1: 1^3 = \frac{1^2(1+1)^2}{4} = 1$. True.

 (2) *Induction step:* Assume S_k . Deduce S_{k+1} .

$$1^3 + 2^3 + \cdots + k^3 = \frac{k^2(k+1)^2}{4} \quad S_k$$

$$1^3 + 2^3 + \cdots + k^3 + (k+1)^3 = \frac{k^2(k+1)^2}{4} + (k+1)^3$$

$$\begin{aligned} & \text{Adding } (k+1)^3 \\ &= \frac{k^2(k+1)^2 + 4(k+1)^3}{4} \end{aligned}$$

$$= \frac{(k+1)^2}{4} [k^2 + 4(k+1)]$$

$$= \frac{(k+1)^2}{4} (k^2 + 4k + 4)$$

$$= \frac{(k+1)^2(k+2)^2}{4}$$

$$21. S_n: 1^5 + 2^5 + 3^5 + \cdots + n^5 = \frac{n^2(n+1)^2(2n^2+2n-1)}{12}$$

$$S_1: 1^5 = \frac{1^2(1+1)^2(2 \cdot 1^2 + 2 \cdot 1 - 1)}{12}$$

$$S_k: 1^5 + 2^5 + 3^5 + \cdots + k^5 = \frac{k^2(k+1)^2(2k^2+2k-1)}{12}$$

$$S_{k+1}: 1^5 + 2^5 + 3^5 + \cdots + k^5 + (k+1)^5 = \frac{(k+1)^2[(k+1)+1]^2[2(k+1)^2+2(k+1)-1]}{12}$$

 (1) *Basis step:* $S_1: 1^5 = \frac{1^2(1+1)^2(2 \cdot 1^2 + 2 \cdot 1 - 1)}{12}$. True.

 (2) *Induction step:* Assume S_k :

$$1^5 + 2^5 + \cdots + k^5 = \frac{k^2(k+1)^2(2k^2+2k-1)}{12}$$

$$\begin{aligned} \text{Then } & 1^5 + 2^5 + \cdots + k^5 + (k+1)^5 \\ &= \frac{k^2(k+1)^2(2k^2+2k-1)}{12} + (k+1)^5 \\ &= \frac{k^2(k+1)^2(2k^2+2k-1) + 12(k+1)^5}{12} \\ &= \frac{(k+1)^2(2k^4 + 14k^3 + 35k^2 + 36k + 12)}{12} \\ &= \frac{(k+1)^2(k+2)^2(2k^2+6k+3)}{12} \\ &= \frac{(k+1)^2(k+1+1)^2(2(k+1)^2+2(k+1)-1)}{12}. \end{aligned}$$

$$23. S_n: 2 + 6 + 12 + \cdots + n(n+1) = \frac{n(n+1)(n+2)}{3}$$

$$S_1: 1(1+1) = \frac{1(1+1)(1+2)}{3}$$

$$S_k: 2 + 6 + 12 + \cdots + k(k+1) = \frac{k(k+1)(k+2)}{3}$$

$$S_{k+1}: 2 + 6 + 12 + \cdots + k(k+1) + (k+1)[(k+1)+1] = \frac{(k+1)[(k+1)+1][(k+1)+2]}{3}$$

 (1) *Basis step:* $S_1: 1(1+1) = \frac{1(1+1)(1+2)}{3}$. True.

 (2) *Induction step:* Assume S_k :

$$2 + 6 + 12 + \cdots + k(k+1) = \frac{k(k+1)(k+2)}{3}$$

$$\begin{aligned} \text{Then } & 2 + 6 + 12 + \cdots + k(k+1) + (k+1)(k+1+1) \\ &= \frac{k(k+1)(k+2)}{3} + (k+1)(k+2) \\ &= \frac{k(k+1)(k+2) + 3(k+1)(k+2)}{3} \\ &= \frac{(k+1)(k+2)(k+3)}{3} \\ &= \frac{(k+1)(k+1+1)(k+1+2)}{3}. \end{aligned}$$

$$25. S_n: a_1 + (a_1 + d) + (a_1 + 2d) + \cdots + [a_1 + (n-1)d] = \frac{n}{2} [2a_1 + (n-1)d]$$

$$S_1: a_1 = \frac{1}{2}[2a_1 + (1 - 1)d]$$

$$S_k: a_1 + (a_1 + d) + (a_1 + 2d) + \cdots + [a_1 + (k - 1)d] = \frac{k}{2}[2a_1 + (k - 1)d]$$

$$S_{k+1}: a_1 + (a_1 + d) + (a_1 + 2d) + \cdots + [a_1 + (k - 1)d] + [a_1 + ((k + 1) - 1)d] = \frac{k + 1}{2}[2a_1 + ((k + 1) - 1)d]$$

(1) *Basis step:* Since $\frac{1}{2}[2a_1 + (1 - 1)d] = \frac{1}{2} \cdot 2a_1 = a_1$, S_1 is true.

(2) *Induction step:* Assume S_k . Deduce S_{k+1} . Starting with the left side of S_{k+1} , we have

$$\underbrace{a_1 + (a_1 + d) + \cdots + [a_1 + (k - 1)d]}_{\frac{k}{2}[2a_1 + (k - 1)d]} + [a_1 + kd]$$

$$= \frac{k}{2}[2a_1 + (k - 1)d] + [a_1 + kd]$$

By S_k

$$= \frac{k[2a_1 + (k - 1)d]}{2} + \frac{2[a_1 + kd]}{2}$$

$$= \frac{2ka_1 + k(k - 1)d + 2a_1 + 2kd}{2}$$

$$= \frac{2a_1(k + 1) + k(k - 1)d + 2kd}{2}$$

$$= \frac{2a_1(k + 1) + (k - 1 + 2)kd}{2}$$

$$= \frac{2a_1(k + 1) + (k + 1)kd}{2}$$

$$= \frac{k + 1}{2}[2a_1 + kd].$$

26. [9.1], [9.3], [9.5], [9.6] (5, 3) 27. [9.2], [9.3], [9.5], [9.6] (2, -3, 4) 28. [9.1], [9.3], [9.5], [9.6] Hardback: 50; paperback: 30 29. [9.2], [9.3], [9.5], [9.6] 1.5%: \$800; 2%: \$1600; 3%: \$2000

31. S_n : $x + y$ is a factor of $x^{2n} - y^{2n}$.
 S_1 : $x + y$ is a factor of $x^2 - y^2$.
 S_k : $x + y$ is a factor of $x^{2k} - y^{2k}$.
 S_{k+1} : $x + y$ is a factor of $x^{2(k+1)} - y^{2(k+1)}$.

(1) *Basis step:* S_1 : $x + y$ is a factor of $x^2 - y^2$. True.
 S_2 : $x + y$ is a factor of $x^4 - y^4$. True.

(2) *Induction step:* Assume S_{k-1} : $x + y$ is a factor of $x^{2(k-1)} - y^{2(k-1)}$. Then $x^{2(k-1)} - y^{2(k-1)} = (x + y)Q(x)$ for some polynomial $Q(x)$.

Assume S_k : $x + y$ is a factor of $x^{2k} - y^{2k}$. Then $x^{2k} - y^{2k} = (x + y)P(x)$ for some polynomial $P(x)$.

$$x^{2(k+1)} - y^{2(k+1)} = (x^{2k} - y^{2k})(x^2 + y^2) - (x^{2(k-1)} - y^{2(k-1)})(x^2y^2)$$

$$= (x + y)P(x)(x^2 + y^2) - (x + y)Q(x)(x^2y^2)$$

$$= (x + y)[P(x)(x^2 + y^2) - Q(x)(x^2y^2)]$$

so $x + y$ is a factor of $x^{2(k+1)} - y^{2(k+1)}$.

33. S_2 : $\log_a(b_1b_2) = \log_a b_1 + \log_a b_2$
 S_k : $\log_a(b_1b_2 \cdots b_k) = \log_a b_1 + \log_a b_2 + \cdots + \log_a b_k$

$$S_{k+1}: \log_a(b_1b_2 \cdots b_{k+1}) = \log_a b_1 + \log_a b_2 + \cdots + \log_a b_{k+1}$$

(1) *Basis step:* S_2 is true by the properties of logarithms.

(2) *Induction step:* Let k be a natural number $k \geq 2$.

Assume S_k . Deduce S_{k+1} .

$$\log_a(b_1b_2 \cdots b_{k+1}) \quad \text{Left side of } S_{k+1}$$

$$= \log_a(b_1b_2 \cdots b_k) + \log_a b_{k+1} \quad \text{By } S_2$$

$$= \log_a b_1 + \log_a b_2 + \cdots + \log_a b_k + \log_a b_{k+1}$$

35. S_2 : $\frac{z_1 + z_2}{(a + bi) + (c + di)} = \frac{\bar{z}_1 + \bar{z}_2}{(a + bi) + (c + di)}$

$$\frac{z_1 + z_2}{(a + bi) + (c + di)} = \frac{\bar{z}_1 + \bar{z}_2}{(a + bi) + (c + di)}$$

$$\frac{z_1 + z_2 + \cdots + z_k}{(z_1 + z_2 + \cdots + z_k) + z_{k+1}} = \frac{\bar{z}_1 + \bar{z}_2 + \cdots + \bar{z}_k}{\bar{z}_1 + \bar{z}_2 + \cdots + \bar{z}_k + \bar{z}_{k+1}}$$

$$S_k: \frac{z_1 + z_2 + \cdots + z_k}{(z_1 + z_2 + \cdots + z_k) + z_{k+1}} = \frac{\bar{z}_1 + \bar{z}_2 + \cdots + \bar{z}_k}{\bar{z}_1 + \bar{z}_2 + \cdots + \bar{z}_k + \bar{z}_{k+1}}$$

By S_2
By S_k

37. S_1 : i is either i or -1 or $-i$ or 1 .

S_k : i^k is either i or -1 or $-i$ or 1 .

$i^{k+1} = i^k \cdot i$ is then $i \cdot i = -1$ or $-1 \cdot i = -i$ or $-i \cdot i = 1$ or $1 \cdot i = i$.

39. S_1 : 3 is a factor of $1^3 + 2 \cdot 1$.

S_k : 3 is a factor of $k^3 + 2k$, i.e., $k^3 + 2k = 3 \cdot m$.

S_{k+1} : 3 is a factor of $(k + 1)^3 + 2(k + 1)$.

Consider

$$(k + 1)^3 + 2(k + 1) = k^3 + 3k^2 + 5k + 3$$

$$= (k^3 + 2k) + 3k^2 + 3k + 3$$

$$= 3m + 3(k^2 + k + 1).$$

A multiple of 3

Mid-Chapter Mixed Review: Chapter 11

1. False 2. True 3. False 4. False 5. 8, 11, 14, 17; 32; 47 6. 0, -1, 2, -3; 8; -13 7. $a_n = 3n$
 8. $a_n = (-1)^n n^2$ 9. $1\frac{7}{8}$, or $\frac{15}{8}$ 10. $2 + 6 + 12$

+ 20 + 30 = 70 11. $\sum_{k=1}^{\infty} (-1)^k 4k$ 12. 2, 6, 22, 86

13. -5 14. 22 15. 21 16. 696 17. $-\frac{1}{2}$

18. (a) 8; (b) $\frac{1023}{16}$, or 63.9375 19. $-\frac{16}{3}$ 20. Does not exist

21. 126 plants 22. \$6369.70

23. S_n : $1 + 4 + 7 + \cdots + (3n - 2) = \frac{1}{2}n(3n - 1)$

$$S_1: 3 \cdot 1 - 2 = \frac{1}{2} \cdot 1(3 \cdot 1 - 1)$$

$$S_k: 1 + 4 + 7 + \cdots + (3k - 2) = \frac{1}{2}k(3k - 1)$$

$$S_{k+1}: 1 + 4 + 7 + \cdots + (3k - 2) + [3(k + 1) - 2]$$

$$= \frac{1}{2}(k + 1)[3(k + 1) - 1]$$

$$= \frac{1}{2}(k + 1)(3k + 2)$$

(1) *Basis step:* S_1 : $3 \cdot 1 - 2 = \frac{1}{2} \cdot 1(3 \cdot 1 - 1)$. True

(2) *Induction step:* Assume S_k :

$$1 + 4 + 7 + \cdots + (3k - 2) = \frac{1}{2}k(3k - 1).$$

Then $1 + 4 + 7 + \cdots + (3k - 2) + [3(k + 1) - 2]$

$$= \frac{1}{2}k(3k - 1) + [3(k + 1) - 2]$$

$$= \frac{3}{2}k^2 - \frac{1}{2}k + 3k + 1$$

$$= \frac{3}{2}k^2 + \frac{5}{2}k + 1$$

$$= \frac{1}{2}(3k^2 + 5k + 2)$$

$$= \frac{1}{2}(k + 1)(3k + 2).$$

24. The first formula can be derived from the second by substituting $a_1 + (n - 1)d$ for a_n . When the first and last terms of the sum are known, the second formula is the better one to use. If the last term is not known, the first formula allows us to compute the sum in one step without first finding a_n .

$$\begin{aligned} 25. & 1 + 2 + 3 + \cdots + 100 \\ &= (1 + 100) + (2 + 99) + (3 + 98) + \cdots + \\ & \quad (50 + 51) \\ &= \underbrace{101 + 101 + 101 + \cdots + 101}_{50 \text{ addends of } 101} \\ &= 50 \cdot 101 \\ &= 5050 \end{aligned}$$

A formula for the first n natural numbers is $\frac{n}{2}(1 + n)$.

26. Answers may vary. One possibility is given. Casey invests \$900 at 8% interest, compounded annually. How much will be in the account at the end of 40 yr? 27. We can prove an infinite sequence of statements S_n by showing that a basis statement S_1 is true and then that for all natural numbers k , if S_k is true, then S_{k+1} is true.

Exercise Set 11.5

1. 720 3. 604,800 5. 120 7. 1 9. 3024 11. 120
 13. 120 15. 1 17. 6,497,400 19. $n(n - 1)(n - 2)$
 21. n 23. $6! = 720$ 25. $9! = 362,880$ 27. ${}_9P_4 = 3024$
 29. ${}_5P_5 = 120$; $5^5 = 3125$ 31. ${}_5P_5 \cdot {}_4P_4 = 2880$
 33. $8 \cdot 10^6 = 8,000,000$; 8 million 35. $\frac{9!}{2!3!4!} = 1260$
 37. (a) ${}_6P_5 = 720$; (b) $6^5 = 7776$; (c) $1 \cdot {}_5P_4 = 120$;
 (d) $1 \cdot 1 \cdot {}_4P_3 = 24$ 39. (a) 10^5 , or 100,000; (b) 100,000
 41. (a) $10^9 = 1,000,000,000$; (b) yes 42. $[1.5] \frac{9}{4}$, or 2.25
 43. $[3.2] - 3, 2$ 44. $[3.2] \frac{3 \pm \sqrt{17}}{4}$ 45. $[4.4] -2, 1, 5$
 47. 8 49. 11 51. $n - 1$

Exercise Set 11.6

1. 78 3. 78 5. 7 7. 10 9. 1 11. 15
 13. 128 15. 270,725 17. 13,037,895 19. n
 21. 1 23. ${}_{23}C_4 = 8855$ 25. ${}_{13}C_{10} = 286$
 27. $\binom{10}{7} \cdot \binom{5}{3} = 1200$ 29. $\binom{52}{5} = 2,598,960$
 31. (a) ${}_{31}P_2 = 930$; (b) $31^2 = 961$; (c) ${}_{31}C_2 = 465$
 32. $[1.5] - \frac{17}{2}$ 33. $[3.2] - 1, \frac{3}{2}$ 34. $[3.2] \frac{-5 \pm \sqrt{21}}{2}$
 35. $[4.4] -4, -2, 3$ 37. $\binom{13}{5} = 1287$ 39. $\binom{n}{2}; 2\binom{n}{2}$
 41. 4 43. 7 45. Line segments:

$${}_nC_2 = \frac{n!}{2!(n-2)!} = \frac{n(n-1)(n-2)!}{2 \cdot 1 \cdot (n-2)!} = \frac{n(n-1)}{2}$$

Diagonals: The n line segments that form the sides of the n -gon are not diagonals. Thus the number of diagonals is

$$\begin{aligned} {}_nC_2 - n &= \frac{n(n-1)}{2} - n \\ &= \frac{n^2 - n - 2n}{2} = \frac{n^2 - 3n}{2} \\ &= \frac{n(n-3)}{2}, n \geq 4. \end{aligned}$$

Let D_n be the number of diagonals of an n -gon. Prove the result above for diagonals using mathematical induction.

$$S_n: D_n = \frac{n(n-3)}{2}, \text{ for } n = 4, 5, 6, \dots$$

$$S_4: D_4 = \frac{4 \cdot 1}{2}$$

$$S_k: D_k = \frac{k(k-3)}{2}$$

$$S_{k+1}: D_{k+1} = \frac{(k+1)(k-2)}{2}$$

(1) *Basis step:* S_4 is true (a quadrilateral has 2 diagonals).

(2) *Induction step:* Assume S_k . Note that when an additional vertex V_{k+1} is added to the k -gon, we gain k segments, 2 of which are sides of the $(k+1)$ -gon, and a former side $\overline{V_1V_k}$ becomes a diagonal. Thus the additional number of diagonals is $k - 2 + 1$, or $k - 1$. Then the new total of diagonals is $D_k + (k - 1)$, or

$$\begin{aligned} D_{k+1} &= D_k + (k - 1) \\ &= \frac{k(k-3)}{2} + (k - 1) \quad \text{By } S_k \\ &= \frac{(k+1)(k-2)}{2} \end{aligned}$$

Exercise Set 11.7

1. $x^4 + 20x^3 + 150x^2 + 500x + 625$
 3. $x^5 - 15x^4 + 90x^3 - 270x^2 + 405x - 243$
 5. $x^5 - 5x^4y + 10x^3y^2 - 10x^2y^3 + 5xy^4 - y^5$
 7. $15,625x^6 + 75,000x^5y + 150,000x^4y^2 + 160,000x^3y^3 + 96,000x^2y^4 + 30,720xy^5 + 4096y^6$
 9. $128t^7 + 448t^5 + 672t^3 + 560t + 280t^{-1} + 84t^{-3} + 14t^{-5} + t^{-7}$ 11. $x^{10} - 5x^8 + 10x^6 - 10x^4 + 5x^2 - 1$
 13. $125 + 150\sqrt{5}t + 375t^2 + 100\sqrt{5}t^3 + 75t^4 + 6\sqrt{5}t^5 + t^6$ 15. $a^9 - 18a^7 + 144a^5 - 672a^3 + 2016a - 4032a^{-1} + 5376a^{-3} - 4608a^{-5} + 2304a^{-7} - 512a^{-9}$
 17. $140\sqrt{2}$ 19. $x^{-8} + 4x^{-4} + 6 + 4x^4 + x^8$
 21. $21a^5b^2$ 23. $-252x^5y^5$ 25. $-745,472a^3$
 27. $1120x^{12}y^2$ 29. $-1,959,552u^5v^{10}$ 31. 2^7 , or 128
 33. 2^{24} , or 16,777,216 35. 20 37. $-12 + 316i$
 39. $-7 - 4\sqrt{2}i$ 41. $\sum_{k=0}^n \binom{n}{k} (-1)^k a^{n-k} b^k$
 43. $\sum_{k=1}^n \binom{n}{k} x^{n-k} h^{k-1}$ 44. $[2.2] x^2 + 2x - 2$
 45. $[2.2] 2x^3 - 3x^2 + 2x - 3$ 46. $[2.3] 4x^2 - 12x + 10$
 47. $[2.3] 2x^2 - 1$ 49. $3, 9, 6 \pm 3i$ 51. $-4320x^6y^{9/2}$

53. $-\frac{35}{x^{1/6}}$ 55. 2^{100} 57. $[\log_a(xt)]^{23}$

59. (1) *Basis step:* Since $a + b = (a + b)^1$, S_1 is true.

(2) *Induction step:* Let S_k be the statement of the binomial theorem with n replaced by k . Multiply both sides of S_k by $(a + b)$ to obtain

$$\begin{aligned} (a + b)^{k+1} &= \left[a^k + \dots + \binom{k}{r-1} a^{k-(r-1)} b^{r-1} \right. \\ &\quad \left. + \binom{k}{r} a^{k-r} b^r + \dots + b^k \right] (a + b) \\ &= a^{k+1} + \dots + \left[\binom{k}{r-1} + \binom{k}{r} \right] a^{(k+1)-r} b^r + \dots + b^{k+1} \\ &= a^{k+1} + \dots + \binom{k+1}{r} a^{(k+1)-r} b^r + \dots + b^{k+1}. \end{aligned}$$

This proves S_{k+1} , assuming S_k . Hence S_n is true for $n = 1, 2, 3, \dots$

Exercise Set 11.8

1. (a) 0.18, 0.24, 0.23, 0.23, 0.12; (b) Opinions may vary, but it seems that people tend not to pick the first or last numbers.

3. 11,700 pieces 5. (a) $\frac{2}{7}$; (b) $\frac{5}{7}$; (c) 0; (d) 1 7. $\frac{1}{2}$

9. (a) $\frac{1}{13}$; (b) $\frac{2}{13}$; (c) $\frac{1}{4}$; (d) $\frac{1}{26}$ 11. $\frac{1}{5525}$ 13. $\frac{135}{323}$

15. $\frac{1}{108,290}$ 17. $\frac{33}{66,640}$ 19. (a) HHH, HHT, HTH, HTT, THH, THT, TTH, TTT; (b) $\frac{3}{8}$; (c) $\frac{7}{8}$; (d) $\frac{7}{8}$; (e) $\frac{3}{8}$ 21. $\frac{9}{19}$

23. $\frac{1}{38}$ 25. $\frac{18}{19}$ 27. $\frac{9}{19}$ 29. [1.5] Zero 30. [5.1] One-to-one 31. [1.2] Function; domain; range; domain; range

32. [1.5] Zero 33. [11.6] Combination 34. [2.5] Inverse variation 35. [4.3] Factor 36. [11.3] Geometric sequence

37. (a) $4 \cdot \left(\frac{13}{5}\right) - 4 - 36 = 5108$; (b) 0.0475

39. (a) $13 \cdot \binom{4}{3} \cdot \binom{48}{2} - 3744$, or 54,912;

(b) $\frac{54,912}{\binom{52}{5}} \approx 0.0211$

Review Exercises: Chapter 11

1. True 2. False 3. True 4. False 5. $-\frac{1}{2}, \frac{4}{17}$, $-\frac{9}{82}, \frac{16}{257}$, $-\frac{121}{14,642}$, $-\frac{529}{279,842}$ 6. $(-1)^{n+1}(n^2 + 1)$

7. $\frac{3}{2} - \frac{9}{8} + \frac{27}{26} - \frac{81}{80} = \frac{417}{1040}$ 8. $\sum_{k=1}^7 (k^2 - 1)$ 9. $\frac{15}{4}$

10. $a + 4b$ 11. 531 12. 20,100 13. 11 14. -4

15. $n = 6$, $S_n = -126$ 16. $a_1 = 8$, $a_5 = \frac{1}{2}$ 17. Does not exist 18. $\frac{3}{11}$ 19. $\frac{3}{8}$ 20. $\frac{241}{99}$ 21. $5\frac{4}{5}, 6\frac{3}{5}, 7\frac{2}{5}, 8\frac{1}{5}$

22. 167.3 ft 23. \$45,993.04 24. (a) \$7.38;

(b) \$1365.10 25. \$88,888,888,889

26. $S_n: 1 + 4 + 7 + \dots + (3n - 2) = \frac{n(3n - 1)}{2}$

$S_1: 1 = \frac{1(3 - 1)}{2}$

$S_k: 1 + 4 + 7 + \dots + (3k - 2) = \frac{k(3k - 1)}{2}$

$S_{k+1}: 1 + 4 + 7 + \dots + (3k - 2) + [3(k + 1) - 2]$
 $= 1 + 4 + 7 + \dots + (3k - 2) + (3k + 1)$
 $= \frac{(k + 1)(3k + 2)}{2}$

(1) *Basis step:* $\frac{1(3 - 1)}{2} = \frac{2}{2} = 1$ is true.

(2) *Induction step:* Assume S_k . Add $(3k + 1)$ on both sides.
 $1 + 4 + 7 + \dots + (3k - 2) + (3k + 1)$
 $= \frac{k(3k - 1)}{2} + (3k + 1) = \frac{k(3k - 1)}{2} + \frac{2(3k + 1)}{2}$
 $= \frac{3k^2 - k + 6k + 2}{2} = \frac{3k^2 + 5k + 2}{2}$
 $= \frac{(k + 1)(3k + 2)}{2}$

27. $S_n: 1 + 3 + 3^2 + \dots + 3^{n-1} = \frac{3^n - 1}{2}$

$S_1: 1 = \frac{3^1 - 1}{2}$

$S_k: 1 + 3 + 3^2 + \dots + 3^{k-1} = \frac{3^k - 1}{2}$

$S_{k+1}: 1 + 3 + 3^2 + \dots + 3^{(k+1)-1} = \frac{3^{k+1} - 1}{2}$

(1) *Basis step:* $\frac{3^1 - 1}{2} = \frac{2}{2} = 1$ is true.

(2) *Induction step:* Assume S_k . Add 3^k on both sides.
 $1 + 3 + \dots + 3^{k-1} + 3^k$
 $= \frac{3^k - 1}{2} + 3^k = \frac{3^k - 1}{2} + 3^k \cdot \frac{2}{2}$
 $= \frac{3 \cdot 3^k - 1}{2} = \frac{3^{k+1} - 1}{2}$

28.

$S_n: \left(1 - \frac{1}{2}\right)\left(1 - \frac{1}{3}\right) \dots \left(1 - \frac{1}{n}\right) = \frac{1}{n}$

$S_2: \left(1 - \frac{1}{2}\right) = \frac{1}{2}$

$S_k: \left(1 - \frac{1}{2}\right)\left(1 - \frac{1}{3}\right) \dots \left(1 - \frac{1}{k}\right) = \frac{1}{k}$

$S_{k+1}: \left(1 - \frac{1}{2}\right)\left(1 - \frac{1}{3}\right) \dots \left(1 - \frac{1}{k}\right)\left(1 - \frac{1}{k+1}\right) = \frac{1}{k+1}$

(1) *Basis step:* S_2 is true by substitution.

(2) *Induction step:* Assume S_k . Deduce S_{k+1} . Starting with the left side of S_{k+1} , we have

$$\begin{aligned} &\underbrace{\left(1 - \frac{1}{2}\right)\left(1 - \frac{1}{3}\right) \dots \left(1 - \frac{1}{k}\right)}_{\frac{1}{k}} \left(1 - \frac{1}{k+1}\right) \\ &= \frac{1}{k} \cdot \left(1 - \frac{1}{k+1}\right) \quad \text{By } S_k \\ &= \frac{1}{k} \cdot \frac{(k+1) - 1}{k+1} \end{aligned}$$

$$= \frac{1}{k} \cdot \frac{k}{k+1}$$

$$= \frac{1}{k+1} \quad \text{Simplifying}$$

29. $6! = 720$ 30. $9 \cdot 8 \cdot 7 \cdot 6 = 3024$ 31. $\binom{15}{8} = 6435$

32. $24 \cdot 23 \cdot 22 = 12,144$ 33. $\frac{9!}{1!4!2!2!} = 3780$

34. $3 \cdot 4 \cdot 3 = 36$ 35. (a) ${}_6P_5 = 720$; (b) $6^5 = 7776$;

(c) ${}_5P_4 = 120$; (d) ${}_3P_2 = 6$ 36. 2^8 , or 256

37. $m^7 + 7m^6n + 21m^5n^2 + 35m^4n^3 + 35m^3n^4 + 21m^2n^5 + 7mn^6 + n^7$ 38. $x^5 - 5\sqrt{2}x^4 + 20x^3 - 20\sqrt{2}x^2 + 20x - 4\sqrt{2}$ 39. $x^8 - 12x^6y + 54x^4y^2 - 108x^2y^3 + 81y^4$ 40. $a^8 + 8a^6 + 28a^4 + 56a^2 + 70 + 56a^{-2} + 28a^{-4} + 8a^{-6} + a^{-8}$ 41. $-6624 + 16,280i$

42. $220a^9x^3$ 43. $-\binom{18}{11}128a^7b^{11}$ 44. $\frac{1}{12}; 0$ 45. $\frac{1}{4}$

46. $\frac{6}{5525}$ 47. $\frac{86}{206} \approx 0.42, \frac{97}{206} \approx 0.47, \frac{23}{206} \approx 0.11$

48. B 49. A 50. D 51. S_1 fails for both (a) and (b).

52. $\frac{a_{k+1}}{a_k} = r_1, \frac{b_{k+1}}{b_k} = r_2$, so $\frac{a_{k+1}b_{k+1}}{a_k b_k} = r_1 r_2$, a constant.

53. (a) No (unless a_n is all positive or all negative); (b) yes; (c) yes; (d) no (unless a_n is constant); (e) no (unless a_n is constant); (f) no (unless a_n is constant) 54. $-2, 0, 2, 4$

55. $\frac{1}{2}, -\frac{1}{6}, \frac{1}{18}$ 56. $\left(\log \frac{x}{y}\right)^{10}$ 57. 18 58. 36 59. -9

60. Put the following in the form of a paragraph.

First find the number of seconds in a year (365 days):

$$365 \text{ days} \cdot \frac{24 \text{ hr}}{1 \text{ day}} \cdot \frac{60 \text{ min}}{1 \text{ hr}} \cdot \frac{60 \text{ sec}}{1 \text{ min}} = 31,536,000 \text{ sec.}$$

The number of arrangements possible is $15!$.

The time is $\frac{15!}{31,536,000} \approx 41,466 \text{ yr.}$ 61. For each circular

arrangement of the numbers on a clock face, there are 12 distinguishable ordered arrangements on a line. The number of arrangements of 12 objects on a line is ${}_{12}P_{12}$, or 12!. Thus the number of circular permutations is

$$\frac{{}_{12}P_{12}}{12} = \frac{12!}{12} = 11! = 39,916,800. \quad \text{In general, for each}$$

circular arrangement of n objects, there are n distin-

guishable ordered arrangements on a line. The total number of arrangements of n objects on a line is ${}_nP_n$, or $n!$.

Thus the number of circular permutations is

$$\frac{n!}{n} = \frac{n(n-1)!}{n} = (n-1)!. \quad 62. \text{ Choosing } k \text{ objects from}$$

a set of n objects is equivalent to not choosing the other $n - k$ objects. 63. Order is considered in a combination lock.

64. In expanding $(a + b)^n$, it would probably be better to use Pascal's triangle when n is relatively small. When n is large, and many rows of Pascal's triangle must be computed to get to the

$(n + 1)$ st row, it would probably be better to use factorial notation. In addition, factorial notation allows us to write a particular term of the expansion more efficiently than Pascal's triangle does.

Test: Chapter 11

1. [11.1] -43 2. [11.1] $\frac{2}{3}, \frac{3}{4}, \frac{4}{5}, \frac{5}{6}, \frac{6}{7}$

3. [11.1] $2 + 5 + 10 + 17 = 34$ 4. [11.1] $\sum_{k=1}^6 4k$

5. [11.1] $\sum_{k=1}^{\infty} 2^k$ 6. [11.1] $3, 2\frac{1}{3}, 2\frac{3}{7}, 2\frac{7}{17}$ 7. [11.2] 44

8. [11.2] 38 9. [11.2] -420 10. [11.2] 675

11. [11.3] $\frac{5}{512}$ 12. [11.3] 1000 13. [11.3] 510

14. [11.3] 27 15. [11.3] $\frac{56}{99}$ 16. [11.1] \$10,000, \$8000, \$6400, \$5120, \$4096, \$3276.80 17. [11.2] \$12.50

18. [11.3] \$74,399.77

19. [11.4]

$$S_n: \quad 2 + 5 + 8 + \cdots + (3n - 1) = \frac{n(3n + 1)}{2}$$

$$S_1: \quad 2 = \frac{1(3 \cdot 1 + 1)}{2}$$

$$S_k: \quad 2 + 5 + 8 + \cdots + (3k - 1) = \frac{k(3k + 1)}{2}$$

$$S_{k+1}: \quad 2 + 5 + 8 + \cdots + (3k - 1) + [3(k + 1) - 1] \\ = \frac{(k + 1)[3(k + 1) + 1]}{2}$$

(1) *Basis step:* $\frac{1(3 \cdot 1 + 1)}{2} = \frac{1 \cdot 4}{2} = 2$, so S_1 is true.

(2) *Induction step:*

$$2 + 5 + 8 + \cdots + (3k - 1) + [3(k + 1) - 1]$$

$$= \frac{k(3k + 1)}{2} + [3k + 3 - 1] \quad \text{By } S_k$$

$$= \frac{3k^2}{2} + \frac{k}{2} + 3k + 2$$

$$= \frac{3k^2}{2} + \frac{7k}{2} + 2 = \frac{3k^2 + 7k + 4}{2}$$

$$= \frac{(k + 1)(3k + 4)}{2} = \frac{(k + 1)[3(k + 1) + 1]}{2}$$

20. [11.5] 3,603,600 21. [11.6] 352,716

22. [11.6] $\frac{n(n-1)(n-2)(n-3)}{24}$ 23. [11.5] ${}_6P_4 = 360$

24. [11.5] (a) $6^4 = 1296$; (b) ${}_5P_3 = 60$

25. [11.6] ${}_{28}C_4 = 20,475$ 26. [11.6] ${}_{12}C_8 \cdot {}_8C_4 = 34,650$

27. [11.7] $x^5 + 5x^4 + 10x^3 + 10x^2 + 5x + 1$

28. [11.7] $35x^3y^4$ 29. [11.7] $2^9 = 512$ 30. [11.8] $\frac{4}{7}$

31. [11.8] $\frac{48}{1001}$ 32. [11.1] B 33. [11.5] 15

This page intentionally left blank

Index of Applications

Agriculture

Baled hay, 105
Corral design, 169, 269
Farm acreage, 762
Garden plantings, 928
Grass seed, 187
Number of farms, 461
Seed test plots, 872
Top apple growers, 760

Astronomy

Comets, 858
Distance between points on the Earth, 535
Distance to a star, 15
Distance to Neptune, 12
Earth's orbit, 15, 850
Hyperbolic mirror, 860
Linear speed of an Earth satellite, 530
Linear speed of the Earth, 534
Meteor Crater, 660
Parabolic orbit, 891
Parsecs, 15
Planet orbits, 847
Radius of the Earth, 503
Satellite location, 568, 638
Weight of an astronaut, 219
Weight on Mars, 218

Automotive

Automobiles produced and VIN number, 78
Car distance, 161–162
Deadly distractions, 280
Fuel economy, 134
Gas mileage, 753
Lamborghini 350 GT, 462

License plates, 955
Maximizing mileage, 810
Miles per car, 155
New tires, 581
Reaction time, 106
Vehicle curb weight, 134

Biology/Life Sciences

Bacteria growth, 411, 919
Eagle's flight, 704
Height of an Indian elephant, 152
Limited population growth in a lake, 455, 463
Maximizing animal support in a forest, 812
Rabbit population growth, 459, 919
Temperature and depth of the Earth, 152
Tomb in the Valley of the Kings, 460–461
Volume of a tree, 216

Business

Advertising, 412, 428, 771, 939
Allocation of resources, 812
Average cost, 359
Bestsellers, 138
Big sites, 280
Book shipments, 762
Break-even point, 753
Circulation of daily newspapers, 308
Coffee mixtures, 752
Consumer complaints, 751
Cost, 791
Cost of business on the Internet, 142
Defective gears, 984
e-commerce, 753, 784, 944
Food service management, 781, 826, 829

Gift cards, 209
Home improvement stores, 186
Internet retail sales, 753
Junk mail, 978
Mail-order business, 752, 760
Maximizing profit, 269, 807–808, 810, 811, 830
Minimizing cost, 269, 810
Packaging and price, 138
Pricing, 155
Printing press, 534
Processing telephone orders, 829
Produce, 780
Production, 775–776, 781, 782, 928
Profit, 778, 782
Sales, 209, 473, 637, 752, 791
Salvage value, 411–412, 919, 988
Snack mixtures, 744–745
Snow sports sales, 99, 120, 758–759
Supermarkets, 126
Ticket sales, 829
Total cost, 93, 106, 152, 155
Total cost, revenue, and profit, 178
Total profit, 370
Trademarks, 826
Volume and cost, 219

Chemistry

Antifreeze mixtures, 753
Boiling point and elevation, 90
Carbon dating, 458, 460, 464, 471, 473
Converting Fahrenheit, Celsius, and Kelvin temperatures, 153, 179–180, 399
Half-life, 456
Hydrogen ion concentration, 427, 473
Mass of a neutron, 14

Mass of a proton, 14
 Newton's law of cooling, 463
 Nuclear disintegration, 15
 pH of substances, 427
 Radioactive decay, 461

Construction

Arch of a circle in carpentry, 74
 Beam deflection, 328
 Box construction, 255, 873
 Bridge expansion, 85
 Building a doll house, 48
 Carpentry, 850, 871
 Chesapeake Bay Bridge Tunnel, 15
 Fencing, 871, 908
 Floor plans, 986
 Framing a closet, 499
 Norman window, 269
 Office dimensions, 872
 Play space, 168
 Rafters for a building, 492–493, 501
 Ramp for the disabled, 97
 Recording studio construction, 662, 666–667
 Road grade, 96, 121
 Safety ladders, 482
 Stacking poles, 925–926, 927
 Storage area, 162–163
 Surveying, 51
 Wedge bevel, 668

Consumer

Baskin-Robbins ice cream, 962
 Bottled water as primary source of drinking water, 59, 137
 Cab fare, 130, 135
 Coffee consumption, 104
 Concert ticket prices, 752
 Condiment choices, 969–970
 Consumption of broccoli, 104
 Cost of a funeral, 400
 Cost of snack food, 762
 First class postage cost, 389, 390
 Mother's Day spending, 760
 Moving costs, 142, 156
 Parking costs, 170
 Price increases, 761
 Restaurant meals, 737, 760
 Spending on pets, 399
 Stamp purchase, 771

Economics

Cost of the census, 400, 411
 Decreasing value of the dollar, 90
 Economic multiplier, 911, 935, 939, 985
 e-filing taxes, 209
 Energy sources in the United States, 60

Income taxes, 134
 IRS tax code, 410
 Median home price, 295, 308
 Sales tax, 217
 Social Security distributions, 473
 Straight-line depreciation, 106, 928–929
 Supply and demand, 464, 747–748, 752
 U.S. exports, 459
 U.S. gross domestic product, 115–117

Education

Foreign students from India, 410
 Forgetting on a final exam, 427
 Grading on a curve, 955
 Homeschooled children in the U.S., 153
 Master's degrees earned by women, 411
 Math proficiency, 120
 Maximizing a test score, 827
 Price of school supplies, 791
 Public libraries, 137
 Student loans, 128–129, 136, 762
 Test options, 962, 988
 Test scores, 229, 826
 Where the textbook dollar goes, 134

Engineering

Beam weight, 217
 Bridge arch, 850
 Bridge supports, 849
 Canyon depth, 672
 Depth of a well, 264–265
 Distance to fire cave, 483
 Electricity, 464
 Field microphone, 839
 Flashlight mirror, 839
 Gears, 662
 Guy wire, 55, 57
 Height of a cliff, 269
 Height of an elevator shaft, 269
 Minimizing power line costs, 171
 Nanowires, 15
 Power of electric current, 229
 Pumping rate and time, 217, 229
 Satellite dish, 839, 908
 Solar power, 461
 Spotlight, 839, 906
 Suspension bridge, 840
 Wind energy capacity, 115, 400
 Windmill power, 90

Environment

Cloud height, 500
 Daylight hours, 583, 637
 Distance to a forest fire, 496
 Earthquake magnitude, 424, 427, 468, 473, 475
 Fire direction, 661

Height of a bamboo plant, 495
 Hydrology, 97
 Lightning detection, 501–502
 Ocean depth, 134
 Recycling plastic bags, 411
 River speed, 534
 Solid waste, 14
 Trash on U.S. roadways, 1, 15
 Volcanic activity, 137
 Water from melting snow, 212
 Weather balloon height, 500
 Wind, 703, 733

Finance

Account overdraft fees, 105
 Amount borrowed, 135
 Amount of an annuity, 935, 938, 946, 985, 988
 Borrowing, 770–771
 Budget, 780
 Child's allowance, 217
 Coins, 826
 College fund, 16
 Compound interest, 13, 16, 308, 382, 404–405, 409, 467, 475, 912, 919
 Credit card debt, 120
 Credit card penalties, 105
 Growth of a stock, 412
 Interest compounded continuously, 452–454, 460, 470, 473
 Interest in a college trust fund, 409
 Interest on a CD, 409
 Investment, 135, 136, 143, 153, 473, 752, 757–758, 761, 791, 826, 828, 871–872, 927, 944
 Loan repayment, 938
 Mortgage payments, 55–56
 Present value, 464
 Retirement account, 16
 Saving for college, 473
 Savings, 16, 927
 Savings account interest rate, 292

General Interest

Aerial photography, 498
 Band formation, 928
 Blouse sizes, 186
 Book arrangements, 986, 987
 Card drawing, 976–977, 979, 986
 Circular arrangements, 987
 Code symbols, 986
 Coin arrangements, 955
 Cremations, 119
 Dog years, 308
 Doubling the thickness of paper, 938
 Drawing coins, 979, 988
 Drawing marbles, 975, 978–979, 984, 988

Favorite pets, 760
 Filling a swimming pool, 214
 Fish attractor, 670
 Flag displays, 986
 Fraternity-sorority names, 986
 Golden Gate Bridge, 500
 Hands on a clock, 535
 Landscaping, 831, 871, 908, 946
 Lawn irrigation, 660
 Letter arrangements, 986
 Linguistics, 978
 Loading ramp, 499
 Mason Dots, 978
 Memorial flag case, 499
 Money combinations, 971
 Norman Rockwell painting, 462
 Numerical relationship, 873, 906
 Pendant design, 187
 Phone numbers, 955
 Picasso painting, 460
 Prize choices, 986
 Program planning, 955
 Quilt design, 501
 Rolling a die, 976, 979
 Selecting a number, 978
 Selecting coins, 979
 Solar cooking, 838
 Spring cleaning, 761
 Street names, 751
 The Ellipse, 849
 Theater seating, 927
 Ticket line, 753
 Time of return, 771
 Tossing three coins, 979
 Total gift, 985
 Tower of Hanoi problem, 945
 Typing speed, 412
 Wheelbarrow, 703
 When was the murder committed?, 463
 Whispering gallery, 847
 Women's shoe sizes, 399
 Zip codes, 955

Geometry

Angle measure, 135
 Angle of depression, 624
 Angle of elevation, 501, 582
 Angle of inclination, 624
 Area of a circle, 219
 Area of a parallelogram, 662, 731
 Area of a quadrilateral, 662
 Area of a triangular garden, 659
 Area of an isosceles triangle, 672
 Area of back yard, 660
 Area of squares, 939
 Banner design, 871
 Carpet area, 168

Diameter of a pipe, 502–503
 Dimensions of a box, 291, 873
 Dimensions of a piece of land, 867
 Dimensions of a poster, 255
 Dimensions of a rectangle, 906
 Dimensions of a rug, 256
 Dimensions of a sail, 671
 Distance across a lake, 735
 Distance from a lighthouse, 501
 Flower garden, 731
 Garden area, 167
 Garden dimensions, 135
 Gas tank volume, 168
 Graphic design, 871
 Guy wire, 55, 57, 624
 Height of a building, 500–501
 Height of a kite, 501
 Height of a mural, 579, 625
 Inscribed pentagon, 500
 Inscribed rectangle, 227
 Inscribed rhombus, 168
 Isosceles trapezoid, 671
 Legs of a right triangle, 255, 291
 Length of a pole, 661
 Length of an antenna, 502
 Lines and triangles from points, 962
 Maximizing area, 262–263, 268, 269, 271, 293, 327
 Maximizing volume, 268, 291
 Minimizing area, 228, 270
 Molding plastics, 169
 Number of diagonals, 370
 Parking lot dimensions, 155
 Perimeter, 906
 Petting zoo dimensions, 256
 Picture frame dimensions, 256, 871
 Poster dimensions, 135
 Radius of a circle, 906
 Sandbox, 731
 Sidewalk width, 291
 Sign dimensions, 871
 Surface area of a right circular cylinder, 186
 Tablecloth area, 227
 Test plot dimensions, 135
 Triangular pennant, 231
 Triangular scarf, 167
 Vietnam Veteran's Memorial, 649, 654
 Volume conversion, 11
 Volume of a box, 169
 Volume of an inscribed cylinder, 171

Government

Election poll, 986
 House of Representatives, 217
 Senate committees, 962
 Social Security numbers, 667

Supreme Court appointments, 77
 Years of presidential elections, 78

Health/Medicine

Added sugar in soft drinks, 751
 Adolescent obesity, 98
 Calcium content in foods, 136
 Child's age related to recommended daily amount of fiber, 75–76
 Declining number who smoke, 155
 Estimating adult height, 101, 105–106
 Fat intake, 217
 Health-care costs, 751
 Ibuprofen in the bloodstream, 305
 Joint-replacement surgery, 751
 Jolts of caffeine, 760
 Lithotripter, 847
 Medical dosage, 358, 383
 Medicare premiums, 410
 Minimizing nutrition cost, 811
 Minimum ideal weight, 105
 Nutrition, 134, 752, 761, 781, 826
 Overweight troops, 410
 Salt consumption, 153
 Spending on antipsychotic drugs, 256
 Spread of an epidemic, 463
 Temperature during an illness, 355, 370, 638
 Threshold weight, 308
 Twin births, 307
 Water weight, 135, 136

Labor

Commission, 135, 752
 Commission versus salary, 135
 Daily doubling salary, 934, 938
 Hourly wages, 135, 925, 988
 Income plans, 141–142, 143
 Job loss, 762
 Maximizing income, 810, 811
 Minimizing salary cost, 812
 Minimum wage, 151
 Salary comparison, 134
 Veterinary assistant's earnings, 211
 Wage sequence, 919
 Work rate, 217

Physics

Acceleration due to gravity, 604–605, 638
 Alternating current, 612
 Angular speed, 529, 530, 534, 535, 579
 Atmospheric drag, 218
 Atmospheric pressure, 474
 Beer–Lambert law, 464
 Bouncing golf ball, 985
 Bouncing ping-pong ball, 938

Boyle's law, 219
 Damped oscillations, 568
 Electrical theory, 612
 Forces, 700, 702, 704, 719, 727, 733
 Height of a ball, 268
 Height of a projectile, 268
 Height of a rocket, 263–264, 268, 384, 386
 Height of a thrown object, 370
 Hooke's law, 218
 Intensity of light, 218
 Linear speed, 529, 530, 534, 575, 579, 582
 Loudness of sound, 428, 473
 Mechanics, 612
 Musical pitch, 157, 218
 Nuclear plant cooling tower, 860
 Parachutist free fall, 927
 Pressure at sea depth, 105
 Projectile motion, 308, 895–896, 897, 907, 909
 Relative aperture, 218
 Ripple spread, 186
 Rotating beacon, 568
 Shipping crate, 701–702, 704
 Sound of an airplane, 503
 Stopping distance, 106, 219, 232
 Suspended block, 716, 718, 730
 Tension, 718, 719, 730
 Time of a free fall, 250, 255, 293
 Water wave, 568

Social Sciences

Adopting abroad, 760
 Committee selection, 961, 962
 Flags of nations, 952
 Forming committees, 961
 Fraternity officers, 962
 Number of handshakes, 370
 Production unit, 979
 Scuba club officers, 988
 Selecting people, 977
 Small group interaction, 928
 Sociological survey, 973–974

Sports/Entertainment

Actors portraying James Bond, 87
 Baseball, 671, 704
 Batting orders, 952
 Biggest weekend at the box office, 761
 Bobsled/luge course, 96–97
 Book titles and American novelists, 86
 Bridge hands, 962
 Bungee jumping, 938
 Carousel, 529, 534
 Circus guy wire, 596
 Circus high wire act, 670
 Climbing wall, 596
 Dart throwing, 974, 980

Double-elimination tournaments, 956
 Earned-run average, 219
 Ferris wheel seats, 518
 Flush, 963
 Four of a kind, 980
 Four Square, 488
 Full house, 963, 980
 Games in a sports league, 962, 963
 Giraffe exhibit, 660–661
 Golf, 168
 Gondola aerial lift, 494–495
 Grade of treadmills, 97, 107
 Hot-air balloons, 488, 703
 In-line skater, 671
 Jogging, 753
 Longest zip line, 477, 499
 Michigan lottery, 960–961
 Mount Rushmore National Memorial, 500
 Movie ticket price, 327
 NASCAR, 72, 78
 NFL stadium elevation, 136
 Nielsen ratings, 135
 Olympic ticket prices, 209
 Poker hands, 962, 979, 980
 Rolling dice, 974–975, 979, 986
 Rope course, 596
 Roulette, 979–980
 Running versus walking, 138
 Setting a fishing line counter, 499
 Single-elimination tournaments, 956
 Ski Dubai Resort, 500
 Slow-pitch softball, 671
 Soccer fields, 129–130, 135
 Survival trip, 671
 Swimming, 399, 672
 T206 Wagner baseball card, 462
 Television ratings, 973
 Television viewers, 134
 Tennis participation, 411
 Theater attendance, 763
 Three of a kind, 980
 Tour de France, 534
 TV channels, 255
 Two pairs, 980
 U.S. Cellular Field, 497–498
 Videos on Hulu, 11
 Walking at Niagara Falls, 492
 Walking speed, 423, 427, 473
 Winter Olympic sites, 759–760
 Winter sports injuries, 751

Statistics/Demographics

Foreign-born population, 72, 385
 Highway deaths, 104
 Median age, 120
 Multigenerational American households, 233, 255

Obesity among American children, 60
 Panama Canal, 65–66
 Population density, 15
 Population growth, 359, 370, 384, 450–452, 454, 459–460, 470, 473, 475, 938
 Population loss, 105, 146
 U.S. census count, 60
 World population growth, 459

Technology

Digital hubs, 142
 Networking sites, 136
 Tech security spending, 14
 World Internet use, 119, 125–126

Transportation

Aerial navigation, 515–516, 517, 519, 573
 Airplane, 624, 671, 703, 704, 718, 731, 733, 746–747
 Airplane distance, 51, 168
 Airplane speed and direction, 127–128, 700–701, 713–714
 Angle of revolution, 531, 533
 Angular speed of a Capstan, 530
 Bicycling speed, 291
 Boat speed, 134
 Boats, 703, 718
 Bus travel, 213
 Decline in air travel, 753
 Distance between towns, 501
 Distance to Nassau, 661
 Distance traveled, 136
 Flying into a headwind or with a tailwind, 136, 153
 John Deere tractor, 534
 Lighthouse, 661
 Lobster boat, 502
 Location, 579, 582, 735
 Long-range navigation system (LORAN), 858
 Luggage wagon, 703
 Minimizing transportation cost, 811
 Motion, 752, 753
 Nautical mile, 604, 638
 Navigation, 861, 907
 Private jets, 104
 Railroad miles, 307
 Rate of travel, 217
 Reconnaissance airplane, 661, 672
 Rising hot-air balloon, 167
 Ships, 671, 703, 718, 733
 Taxi medallions, 387, 410–411
 Tourism, 919
 Train speeds, 136, 251–252
 Transcontinental railroad, 763
 Traveling up or downstream, 136
 Valve cap on a bicycle, 518

Index

- Abscissa, 61
- Absolute value, 6, 53
 - of complex numbers, 674, 722
 - equations with, 280, 289
 - inequalities with, 282, 289
 - and roots, 49, 53
- Absolute value function, 194
- Absorption, coefficient of, 464
- ac*-method of factoring, 26
- Acceleration due to gravity, 604, 638
- Acute angle, 478, 505
- Addition. *See also* Sums.
 - associative property, 5, 53
 - commutative property, 5, 53
 - of complex numbers, 236, 285
 - of exponents, 10, 53
 - of functions, 172, 221
 - of matrices, 772, 821
 - of ordinates, 562
 - of polynomials, 18, 19
 - of radical expressions, 47
 - of rational expressions, 39
 - of vectors, 699, 708, 710, 727, 728
- Addition principle
 - for equations, 31, 53, 122, 148
 - for inequalities, 139, 149
- Addition properties
 - for matrices, 775
 - for real numbers, 5, 53
- Additive identity
 - for matrices, 774, 775
 - for real numbers, 5, 53
 - for vectors, 710, 729
- Additive inverse
 - for matrices, 774
 - for real numbers, 5, 53
- Aerial navigation, 515, 573
- Algebra, fundamental theorem of, 330, 376
- Algebra of functions, 172, 221
- Alternating sequence, 913
- Ambiguous case, 655
- Amplitude, 544, 553, 559, 577, 578
- Angles, 504
 - acute, 478, 505
 - central, 527
 - complementary, 486, 506, 571
 - coterminal, 504, 571
 - decimal degree form, 484
 - of depression, 493
 - direction, 712, 729
 - D°M'S" form, 484
 - drift, 700
 - of elevation, 493
 - initial side, 504
 - between lines, 595
 - negative rotation, 504
 - obtuse, 505
 - positive rotation, 504
 - quadrantal, 510, 572
 - radian measure, 523, 572
 - reference, 512, 572
 - right, 478, 505
 - standard position, 504
 - straight, 505
 - supplementary, 506, 571
 - terminal side, 504
 - between vectors, 715, 730
 - vertex, 504
- Angular speed, 529, 575
- Annuity, 935
- Applications. *See Index of Applications*
- Arc length, 527, 536, 575
- Arccos, 616
- Arcsin, 616
- Arctan, 616
- Area of a triangle, 658, 659, 721
- Argument of $a + bi$, 674
- Arithmetic mean, 928
- Arithmetic progressions. *See* Arithmetic sequences
- Arithmetic sequences, 920, 981
 - common difference, 920, 981
 - n th term, 921, 981
 - sums, 923, 981
- Arithmetic series, 635
- ASK mode, 124
- Associative properties
 - for matrices, 779
 - for real numbers, 5, 53
- Astronomical unit, 12
- Asymptotes
 - crossing, 349, 379
 - of exponential functions, 402, 466
 - horizontal, 345–348, 378
 - of a hyperbola, 852
 - of logarithmic functions, 416, 467
 - oblique, 348, 349, 378
 - slant, 348, 349, 378
 - vertical, 342–345, 378
- Augmented matrix, 764, 821
- AUTO mode, 65
- Average, 928
- Average rate of change, 93, 98, 146, 175
- Axes. *See also* Axis.
 - of a coordinate system, 60
 - of an ellipse, 843
 - of a hyperbola, 851, 852
 - rotation of, 875–880, 902
- Axis
 - conjugate, 852
 - imaginary, 673
 - major, 843
 - minor, 843
 - polar, 686
 - real, 673
 - of symmetry, 257, 287, 832
 - transverse, 851
 - x -, 61
 - y -, 61
- Back-substitution, 755
- Bar graph, 60
- Base
 - change of, 420, 468
 - of an exponential function, 401
 - in exponential notation, 9
- Base e logarithm, 419, 468
- Base–exponent property, 439, 469
- Base-10 logarithm, 418, 468
- Basis step, 940, 982
- Bearing, 496, 515, 573
- Beer–Lambert law, 464
- Bel, 428
- Bevel, 668

- Binomial. *See* Binomials
- Binomial coefficient notation, 958, 983
- Binomial expansion
 $(k + 1)$ st term, 968, 984
 using factorial notation, 967, 984
 using Pascal's triangle, 966, 983
- Binomial theorem, 966, 967, 983
- Binomials, 18
 product of, 20, 53
- Book value, 929
- Break-even point, 753
- Calculator. *See also* Graphing calculator.
 logarithms on, 418
 trigonometric functions on, 485,
 511, 514, 540
- Canceling, 37
- Carbon dating, 458
- Cardiod, 690
- Carry out, 125
- Cartesian coordinate system, 61
- Center
 of circle, 69, 145, 840
 of ellipse, 842
 of hyperbola, 851
- Central angle, 527
- Change-of-base formula, 420, 468
- Checking the solution, 32, 33, 125, 273, 277,
 633
- Circle graph, 60
- Circles, 69, 832, 840
 center, 69, 145, 840
 equation, standard, 69, 145, 840, 898
 graph, 69, 70, 841
 radius, 69, 145, 840
 unit, 75, 520, 573
- Circular arrangements, 987
- Circular functions, 536, 537, 576
- Clearing fractions, 272, 288
- Closed interval, 4
- Coefficient, 17, 296, 372
 of absorption, 464
 binomial, 958, 983
 leading, 17, 296, 372
 of linear correlation, 117
- Coefficient matrix, 764, 821
- Cofactor, 793
- Cofunctions, 486, 487, 570, 597,
 598, 640
- Collecting like (or similar) terms, 18
- Column matrix, 776
- Columns of a matrix, 764
- Combination, linear, of unit vectors,
 711, 729
- Combinations, 956–961, 983
- Combinatorics, 947. *See also*
 Combinations; Permutations.
- Combined variation, 215, 227
- Combining like (or similar) terms, 18
- Common denominator, 39, 40
- Common difference, 920, 981
- Common factors, 22
- Common logarithms, 418
- Common ratio, 929, 982
- Commutative properties
 for matrices, 775
 for real numbers, 5, 53
- Complementary angles, 486, 506, 571
- Completing the square, 244, 286
- Complex conjugates, 238, 285
- Complex numbers, 235, 236, 285
 absolute value, 674, 722
 addition, 236, 285
 argument, 674
 conjugates of, 238, 285
 division of, 239, 285, 678, 723
 graphical representation, 673, 722
 imaginary, 235
 imaginary part, 235, 285
 multiplication of, 236, 285, 677, 723
 polar notation, 674
 powers of, 679, 723
 powers of i , 237
 pure imaginary, 235
 real part, 235, 285
 roots of, 680, 724
 standard notation, 675
 subtraction, 236, 285
 trigonometric notation, 674, 722
- Complex rational expressions, 41
- Component form of a vector, 706, 728
- Components of a vector, 701, 727
 scalar, 705, 728
- Composite function, 179
- Composition of functions, 180, 222
 and inverse functions, 395, 466, 620, 641
 trigonometric, 620, 643
- Compound inequality, 140, 150
- Compound interest, 13, 53, 404, 452, 467, 470
- Conic sections, 832, 885
 circles, 832, 840
 classifying equations, 857
 degenerate, 880
 directrix, in polar form, 885
 discriminant, 880, 902
 eccentricity, 885, 886
 ellipses, 832, 842, 887, 902
 focus, in polar form, 885
 hyperbola, 832, 852, 887, 902
 parabolas, 832, 887, 902
 polar equations, 887, 902
 and rotation of axes, 875–880, 902
- Conjugate axis of hyperbola, 852
- Conjugates
 of complex numbers, 238, 285
 as zeros, 331, 376
 of radical expressions, 49
- Conjunction, 140, 150
- CONNECTED mode, 341
- Connecting the Concepts, 29, 86, 132, 252,
 258, 301, 325, 403, 416, 545, 619, 668,
 857, 961
- Consistent system of equations,
 739, 819
- Constant, variation, 211, 213, 226
- Constant function, 92, 296
- Constant of proportionality, 211,
 213, 226
- Constant term, 17
- Constraints, 806
- Continuous compounding of interest,
 452, 470
- Continuous functions, 298
- Converting
 between degree and radian measure, 525,
 526, 574
 between $D^{\circ}M'S''$ and decimal degree
 notation, 484, 570
 between exponential and logarithmic
 equations, 417
 between parametric and rectangular
 equations, 892–894
 between polar and rectangular coordinates,
 687, 724, 725
 between polar and rectangular equations,
 689, 725, 889, 903
 between radical and exponential notation,
 49, 53
 between trigonometric and standard
 notation, 675, 676
- Cooling, Newton's law of, 463
- Coordinate system
 Cartesian, 61
 polar, 686
- Coordinates, 61
- Correlation, coefficient of, 117
- Correspondence, 76. *See also* Functions;
 Relation.
- Cosecant function, 479, 507, 537, 548, 569
 graph, 548
- Cosine function, 478, 479, 507, 537,
 569, 577
 amplitude, 544, 545
 domain, 543, 545
 graph, 541, 545
 period, 543, 545
 range, 543, 545
- Cosines, law of, 663, 664, 721
- Cost
 fixed, 106
 total, 269
 variable, 106
- Cotangent function, 479, 507, 537, 547,
 548, 569
- Coterminal angles, 504, 571
- Counting principle, fundamental, 948, 982
- Cramer's rule, 796, 797
- Critical value, 365
- Cube root, 45
- Cube root function, 194
- Cubes, factoring sums and differences, 28, 53
- Cubic function, 296, 297
- Cubing function, 194

- Curve, plane, 891, 892, 904
 Curve fitting, 114
- Damped oscillation, 563
 Dead Sea scrolls, 458
 Decay, exponential, 456, 471
 Decay rate, 456, 457, 471
 Decibel, 428
 Decimal degree form, 484
 Decimal notation, 2
 Decomposing a function, 184, 222
 Decomposition, partial fraction, 813
 Decreasing function, 158, 220
 Degenerate conic section, 880
 Degree
 of a polynomial, 17, 18
 of a polynomial function, 296, 372
 of a term, 18
 Degree measure, 484, 504
 converting to radians, 525, 574
 decimal form, 484
 $D^{\circ}M'S''$ form, 484
 DeMoivre, Abraham, 679
 DeMoivre's theorem, 679, 723
 Denominator
 least common, 39, 40
 rationalizing, 48
 Dependent equations, 739, 819
 Dependent variable, 64
 Depreciation, straight-line, 106
 Depression, angle of, 493
 Descartes, René, 335
 Descartes' rule of signs, 336, 377
 Descending order, 17
 Determinants, 792–795, 823
 Diagonals of a polygon, 370
 Difference. *See also* Subtraction.
 common, 920, 981
 of cubes, factoring, 28, 53
 of functions, 172, 221
 of logarithms, 432, 436, 468
 square of, 20, 53
 of squares, factoring, 27
 Difference identities, 589–593, 639
 Difference quotient, 175, 222
 Dimensions of a matrix, 764
 Direct variation, 211, 226
 Direction angle, 712, 729
 Direction of a vector, 697
 Directly proportional, 211, 226
 Directrix
 of a conic section in polar form, 885
 of a parabola, 833
 Discontinuous function, 298
 Discriminant, 248, 287, 880, 902
 Disjunction, 141, 150
 Displacement, 697
 Distance. *See also* Distance formula.
 of a fall, 250
 on the number line, 6
 projectile motion, 263
 major axis, 843
 minor axis, 843
 vertices, 843
 x -, y -intercepts, 843
 Distance formula. *See also* Distance.
 for motion, 127
 between points, 66, 144
 Distinguishable permutations, 954, 983
 Distributive property
 for matrices, 779
 for real numbers, 5, 53
 Dividend, 320, 321
 Division
 of complex numbers, 239, 285, 678, 723
 of exponential expressions, 10, 53
 of functions, 172, 221
 of polynomials, 320–324, 375
 of radical expressions, 46, 53
 of rational expressions, 37
 synthetic, 322, 375
 Divisor, 320, 321
 $D^{\circ}M'S''$ form, 484
 Domain
 of a function, 76, 82, 145, 174, 182, 221
 polynomial, 298
 rational, 341
 trigonometric, 536, 543, 545, 575
 of a rational expression, 36
 of a relation, 78
 restricting, 396
 DOT mode, 341
 Dot product, 714, 728
 Double angle identities, 599–601, 640
 Doubling time, 451, 454, 470
 DRAW menu, 70
 Drift angle, 700
- e , 405, 467
 Earthquake magnitude, 424, 468
 Eccentricity
 of a conic in polar form, 885, 886
 of an ellipse, 849, 885, 886
 of a hyperbola, 860, 885, 886
 Economic multiplier effect, 935
 Element
 in a function's domain, 76
 of a set, 3
 Elements of a matrix, 764
 Elevation, angle of, 493
 Eliminating the parameter, 892
 Eliminating the xy -term, 879, 902
 Elimination
 Gauss–Jordan, 767
 Gaussian, 754, 820
 Elimination method, 740, 820
 Ellipse, 842, 887, 902
 center, 842
 eccentricity, 849, 885, 886
 equations, 843, 845, 880, 887, 899, 902
 foci, 842
 graphs, 843, 845
- Empty set, 282
 End behavior, 299, 300, 373
 Endpoints, 3
 Entries of a matrix, 764
 Equality of matrices, 772
 Equally likely outcomes, 975
 Equation, 31, 121
 with absolute value, 280, 289
 checking the solutions, 32, 33, 273, 277
 of circles, 69, 145, 840, 880, 887, 898, 902
 of ellipses, 843, 845, 880, 887, 899, 902
 equivalent, 31
 exponential, 417, 439
 graphs of, 62, 144. *See also* Graphs.
 of hyperbolas, 593, 596, 617, 852, 855, 880, 887, 900, 902
 of inverse relations, 388
 linear, 31, 100, 121
 logarithmic, 417, 445
 logistic, 455
 matrix, 789
 in one variable, 121
 of parabolas, 833, 835, 880, 887, 898, 902
 parametric, 892, 904
 point–slope, 110, 147
 polar, 688
 of conics, 887, 902
 Pythagorean, 481
 quadratic, 31, 241, 286
 quadratic in form, 249, 287
 radical, 274, 289
 rational, 272, 289
 rectangular, 688
 reducible to quadratic, 249, 287
 related, 360, 800
 roots of, 241. *See also* Solutions, of equations.
 slope–intercept, 100, 109, 146, 147
 solution of, 61
 solution set, 31
 solving, 31, 53, 122, 123, 148, 241, 272, 274, 280, 286, 289, 439
 solving systems of. *See* Solving systems of equations
 systems of, 738, 819
 in three variables, 754
 translating to, 125
 trigonometric, 625, 644
 Equation–editor screen, 64
 Equilibrium, forces in, 715, 730
 Equilibrium point, 464
 Equilibrium price, 464
 Equivalent equations, 31
 systems, 742
 Equivalent expressions, 38
 Equivalent inequalities, 138

- Equivalent vectors, 697, 707, 726, 728
Euler, Leonhard, 405
Evaluating a determinant, 792–795
Even functions, 193, 223
Even multiplicity, 303, 373
Even roots, 46, 53
Event, 974
Experimental probability, 972, 973, 984
Exponent(s), 9
 integer, 8
 negative, 9
 properties of, 10, 53
 rational, 49, 53
 of zero, 9
Exponential decay model, 456, 471
Exponential equations, 417, 439
Exponential function, 401, 466
 asymptote, 402, 403, 466
 base, 401
 graphs, 407
 inverses, 413. *See also* Logarithmic functions.
 properties, 403
 y -intercept, 403, 466
Exponential growth model, 450, 470
 and doubling time, 451, 454, 470
 growth rate, 450, 454
Exponential notation. *See* Exponent(s)
Expressions
 complex rational, 41
 equivalent, 38
 radical, 36
 rational, 36
 with rational exponents, 49, 53
Factor, common, 22
Factor theorem, 324, 376
Factorial notation, 949, 982
 and binomial expansion, 967, 984
Factoring
 ac -method, 26
 common factors, terms with, 22
 completely, 28
 differences of cubes, 28, 53
 differences of squares, 27
 FOIL method, 25
 by grouping, 23
 grouping method, 26
 polynomial functions, 324, 330, 376
 polynomials, 22–29
 strategy, 29
 sums of cubes, 28, 53
 trinomials, 23–27
Factors of polynomials, 320, 324, 376
Familiarize, 125
Feasible solutions, 806, 824
Fibonacci sequence, 919
Finite sequence, 912, 981
Finite series, 915, 981
First coordinate, 61
Fitting a curve to data, 114
Fixed costs, 106
Foci. *See* Focus
Focus
 of a conic in polar form, 885
 of an ellipse, 842
 of a hyperbola, 851
 of a parabola, 832
FOIL, 20
 and factoring, 25
Force, 697
Forces in equilibrium, 715, 730
Formulas, 33
 change-of-base, 420, 468
 compound interest, 13, 53, 404, 452, 467, 470
 diagonals of a polygon, 370
 distance
 of a free fall, 250
 between points, 66, 144
 Heron's, 672
 for inverses of functions, 393, 465
 midpoint, 68, 144
 mortgage payment, 55
 motion, 127
 quadratic, 247, 287
 recursion, 917, 981
 rotation of axes, 877, 902
 savings plan, 16
 simple interest, 128
 solving for a given variable, 33
FRAC feature, 50
Fractional equations. *See* Rational equations
Fractional exponents, 49, 53
Fractional expressions. *See* Rational expressions
Fractions
 clearing, 272, 288
 partial, 813
Functions, 76, 145
 absolute value, 194
 algebra of, 172, 221
 circular, 536, 537, 576
 cofunctions, 486, 487, 570
 composite, 179
 composition of, 180, 222, 620, 643
 constant, 92, 158, 220, 296
 continuous, 298
 as correspondences, 76
 cube root, 194
 cubic, 296, 297
 cubing, 194
 decomposing, 184, 222
 decreasing, 158, 220
 defined piecewise, 163, 221
 difference of, 172, 221
 difference quotient, 175, 222
 discontinuous, 298
 domain, 76, 82, 83, 145, 174, 182, 221
 element, 76
 even, 193, 223
 exponential, 401, 466
 graphs, 80
 greatest integer, 165, 221
 horizontal-line test, 392, 465
 identity, 92, 194
 increasing, 158, 220
 input, 79
 inverse trigonometric, 616, 619, 642
 inverses of, 391, 465
 library of, 194. *See also inside back cover.*
 linear, 92, 296
 logarithmic, 415, 467
 logistic, 456
 nonlinear, 92
 nonpolynomial, 298
 notation for, 79
 objective, 546
 odd, 193, 223
 one-to-one, 390, 465
 output, 79
 periodic, 543, 544, 576
 phase shift, 558, 578
 piecewise, 163, 221
 polynomial, 296, 372
 product of, 172, 221
 quadratic, 241, 286, 296, 297
 quartic, 296
 quotient of, 172, 221
 range, 76, 83, 145
 rational, 340, 378
 reciprocal, 194
 trigonometric, 479, 569
 reflections, 190, 198, 199, 204, 224
 relative maxima and minima, 159, 160, 220
 sequence, 912
 shrinking, 200, 201, 204, 225
 square root, 194
 squaring, 194
 stretching, 200, 201, 204, 225
 sum of, 172, 221
 transformations, 194–204, 224–226, 551–561, 577
 translations, 195–197, 204, 224, 552, 557, 559, 577
 trigonometric, 478, 479, 507, 514, 537, 543, 545, 569
 values, 79, 80, 305, 323, 375
 vertical-line test, 81, 145
 zeros of, 130, 131, 149, 243, 301
Fundamental counting principle, 948, 982
Fundamental theorem of algebra, 330, 376
Gauss, Karl Friedrich, 494, 507
Gauss–Jordan elimination, 507
Gaussian elimination, 494, 560
General term of a sequence, 913, 914
Geometric progressions. *See* Geometric sequences
Geometric sequences, 929, 982
 common ratio, 929, 982
 infinite, 932

- n th term, 930, 982
- sums, 931, 933, 982
- Geometric series, 931
 - infinite, 932, 933, 982
- Grade, 96
- Graph styles, 801
- Graphing calculator
 - and absolute value, 6, 674
 - ANGLE menu, 484, 525
 - and circles, 70, 841, 842
 - coefficient of linear correlation, 117
 - and combinations, 959
 - and complex numbers, 236, 237, 239, 674, 675, 676, 677, 679, 680, 682
 - and composition of functions, 180, 181
 - CONNECTED mode, 341
 - converting to/from degrees and radians, 526
 - converting to/from $D^{\circ}M'S''$ and decimal degree form, 484
 - and cube roots, 46
 - DEGREE mode, 484, 514
 - and determinants, 796
 - DIAGNOSTIC, 117
 - DMS feature, 484
 - $D^{\circ}M'S''$ notation, 484
 - DOT mode, 341, 547
 - DRAW menu, 70
 - and ellipses, 844
 - equation-editor screen, 64
 - and factorial notation, 950
 - FRAC feature, 50
 - and function values, 80, 305
 - graph styles, 587, 599, 801
 - graphing equations, 64
 - graphing logarithmic functions, 421
 - graphing rational functions, 341
 - graphing trigonometric functions, 542, 547
 - and greatest integer function, 166
 - and hyperbolas, 854, 856
 - and identities, 587, 599, 602
 - and inequalities, 139, 140, 141, 801, 802, 804, 805
 - INEQUALZ, 801, 802, 804, 805
 - INTERSECT feature, 123
 - and inverse trigonometric functions, 485, 617
 - and inverses of functions, 394, 421, 485, 617
 - linear regression, 116, 117
 - and logarithms, 418, 419
 - LOGIC menu, 140
 - and matrices, 766, 768, 773, 775, 787, 788, 789, 795
 - MAXIMUM feature, 160
 - MINIMUM feature, 160
 - and n th roots, 46
 - and order of operations, 13
 - and parabolas, 262, 834, 836, 837
 - and parametric equations, 541, 543, 682
 - and permutations, 949, 952
 - and polar equations, 691, 886, 888, 889
 - and polynomial inequalities, 365
 - PolySmlt, 768
 - and probability, 977
 - quadratic regression, 759
 - RADIAN mode, 526, 540
 - and reduced row-echelon form, 768
 - regression, 116, 117, 759
 - and relative maxima and minima, 160
 - row-equivalent operations, 766
 - scatterplot, 114
 - and scientific notation, 12
 - and sequences, 913, 915, 916, 917
 - SEQUENTIAL mode, 587
 - and solving equations, 123, 250, 265, 275, 277, 442, 444, 447, 452, 630, 633
 - and square roots, 46
 - and systems of equations, 738, 864, 866
 - and systems of inequalities, 868
 - TABLE feature, 65, 124
 - TEST menu, 140
 - and trigonometric function values, 485, 511, 514, 540
 - TVM solver, 13
 - VALUE feature, 80
 - viewing window, 64
 - squaring, 70
 - standard, 64
 - and x th roots, 46
 - ZERO feature, 132
 - and zeros of functions, 132, 245, 303, 447, 454
 - ZOOM menu, 64, 70
- Graphs, 60
 - asymptotes. *See* Asymptotes
 - bar, 60
 - circle, 60
 - of circles, 69, 70, 841, 898
 - of complex numbers, 673, 722
 - of conics, polar equations, 887
 - cosecant function, 548
 - cosine function, 541, 543
 - cotangent function, 547
 - ellipses, 843, 845
 - equations, 62, 64, 101, 144
 - exponential functions, 407
 - functions, 80
 - hole in, 353
 - horizontal lines, 92
 - hyperbolas, 852, 855
 - identity function, 92, 194
 - inequalities, 800, 823
 - intercepts, 62, 144. *See also* x -intercept; y -intercept.
 - of intervals, 4
 - inverse function, 394
 - trigonometric, 617
 - inverse relations, 388
 - inverses of exponential functions, 413
 - leading-term test, 300, 372
 - line, 60
 - linear inequalities, 139
 - logarithmic functions, 421, 467
 - and multiplicity of zeros, 303
 - of ordered pairs, 61
 - parabolas, 257, 258, 287, 833, 835, 898
 - parametric equations, 891
 - of points, 61
 - of polar equations, 690, 724
 - of polynomial functions, 309–316, 373
 - quadratic functions, 257–262, 287
 - rational functions, 340, 350, 378
 - reflection, 190, 198, 199, 204, 224
 - rotation of axes, 875–880, 902
 - scatterplot, 114
 - secant function, 548
 - of sequences, 914
 - shrinking, 200, 201, 204, 225
 - sine function, 541, 543
 - solving equations using, 123
 - stretching, 200, 201, 204, 225
 - of sums, 562
 - symmetry, 189–194, 223
 - systems of equations, 738
 - systems of inequalities, 804, 824
 - tangent function, 547
 - transformations, 194–204, 224–226, 551–561, 577
 - translation, 195–197, 204, 224, 551, 556, 557, 559, 578
 - turning point, 309, 373
 - vertical lines, 92
 - x -intercept, 62, 144
 - y -intercept, 62, 99, 144
- Gravity, acceleration due to, 604, 638
- Greater than ($>$), 3
- Greatest integer function, 165, 221
- Gross domestic product, 115
- Grouping, factoring by, 23
- Growth, limited, 454
- Growth model, exponential, 450, 470
- Growth rate, exponential, 450, 454

- Half-angle identities, 601, 602, 641
- Half-life, 456, 457, 471
- Half-open interval, 4
- Half-plane, 800
- Heron's formula, 672
- Hole in a graph, 350
- Hooke's law, 218
- Horizontal asymptotes, 345–348, 378, 402, 466
- Horizontal component of a vector, 701, 727
 - scalar, 705, 728
- Horizontal line, 92, 113, 146
 - slope, 95, 146
- Horizontal-line test, 392, 465
- Horizontal stretching and shrinking, 201, 204, 225, 555, 559, 577
- Horizontal translation, 196, 204, 224, 556, 557, 559, 578

- Hyperbola, 851
 asymptotes, 852
 center, 851
 conjugate axis, 852
 eccentricity, 860, 885, 886
 equations, 852, 855, 880, 887, 900, 902
 foci, 851
 graphs, 852, 855
 transverse axis, 851
 vertices, 851
- Hypotenuse, 47, 478
- i , 234, 285
 powers of, 237
- Identities
 additive
 matrix, 774, 775
 real numbers, 5, 53
 cofunction, 486, 489, 570, 597, 598, 640
 multiplicative
 matrix, 785, 822
 real numbers, 5, 53
 Pythagorean, 584–586, 639
 trigonometric, 487, 570, 584–596,
 597–602, 609, 610, 639–642
 proving, 606, 641
- Identity, 584, 639. *See also* Identities.
- Identity function, 92, 194
- Identity matrix, 785, 822
- Imaginary axis, 673
- Imaginary numbers, 235
- Imaginary part, 235, 285
- Inconsistent system of equations,
 739, 819
- Increasing function, 158, 220
- Independent equations, 739, 819
- Independent variable, 64
- Index
 of a radical, 45
 of summation, 916
- Induction, mathematical, 940, 982
- Induction step, 940, 982
- Inequalities, 138
 with absolute value, 282, 289
 compound, 140, 150
 conjunction, 140, 150
 disjunction, 141, 150
 equivalent, 138
 graphing, 800
 linear, 139, 800
 polynomial, 360, 380
 quadratic, 360
 rational, 365, 381
 solutions, 138, 800
 solving, 138–141, 282, 289
 systems of, 804, 823, 867, 901
- INEQUALZ, 801, 802, 804, 805
- Infinite sequence, 912, 981
- Infinite series, 915, 932
- Initial point of a vector, 698
- Initial side of an angle, 504
- Input, 79
- Integers, 2
 as exponents, 8
- Intercepts, 62, 144. *See also* x -intercept;
 y -intercept.
- Interest
 compound, 13, 53, 404, 467
 continuously, 452, 470
 simple, 128
- Intermediate value theorem, 315, 374
- INTERSECT feature, 123
- Intersect method, 123, 133
- Interval notation, 3, 4
- Inverse of a function. *See* Inverses
- Inverse relation, 388, 465
- Inverse variation, 213, 226
- Inversely proportional, 213, 226
- Inverses
 additive
 of matrices, 774
 of real numbers, 5, 53
 function, 391, 465
 and composition, 395, 466
 exponential, 413
 formula for, 393, 465
 and reflection across $y = x$, 394, 465
 trigonometric, 616, 619, 642
 multiplicative
 of matrices, 786, 822
 of real numbers, 5, 53
 relation, 388, 465
- Invertible matrix, 788
- Irrational numbers, 2
- Irrational zeros, 332, 376
- Irreducible quadratic factor, 813
- Isosceles triangle, 482
- Joint variation, 215, 227
- Jordan, Wilhelm, 767
- $(k + 1)$ st term, binomial expansion,
 968, 984
- Latitude, 604
- Law of cosines, 663, 664, 721
- Law of sines, 652, 720
- Leading coefficient, 17
- Leading 1, 767
- Leading term, 296, 372
- Leading-term test, 300
- Least common denominator (LCD), 39, 40
- Legs of a right triangle, 47
- Length of a vector, 697, 698, 706, 728
- Less than ($<$), 3
- Less than or equal to (\leq), 3
- Libby, Willard E., 456
- Library of functions, 194. *See also* *inside back cover*.
- Light-year, 15
- Like terms, 18
- Limit, infinite geometric series, 933, 982
- Limited population growth, 454
- Limiting value, 455
- Line graph, 60
- Line of symmetry. *See* Axis, of symmetry
- Linear combination of unit vectors,
 711, 729
- Linear correlation, coefficient of, 117
- Linear equations, 31, 100, 121
 in three variables, 574
- Linear functions, 92, 296
 applications, 101
 slope, 93, 146
 zero of, 130
- Linear inequalities, 139, 800
 systems of, 804, 823
- Linear programming, 806
- Linear regression, 116, 117
- Linear speed, 529, 575
- Lines
 angle between, 595
 horizontal, 92, 113, 146
 parallel, 111, 147
 perpendicular, 111, 112, 148
 point-slope equation, 110, 113, 147
 slope of, 93, 113, 146
 slope-intercept equation, 100, 109, 113,
 146, 147
 vertical, 92, 113, 146
- Lithotripter, 847
- \ln , 419
- \log , 418. *See also* Logarithm.
- Logarithm, 417, 467. *See also* Logarithmic
 functions.
 base e , 419, 468
 base-exponent property, 439, 469
 base-10, 418, 468
 a base to a logarithmic power, 435, 469
 of a base to a power, 435, 469
 on a calculator, 418
 change-of-base, 420, 468
 common, 418, 468
 natural, 419, 468
 power rule, 431, 436, 468
 product rule, 430, 436, 468
 properties, 430–432, 436, 468
 quotient rule, 432, 436, 468
- Logarithm function. *See* Logarithmic
 functions
- Logarithmic equality, property of, 440, 469
- Logarithmic equation, 417, 445
- Logarithmic functions, 413–415, 467.
See also Logarithm.
 asymptote, 416, 467
 domain, 416, 467
 graphs, 421, 467
 properties, 416, 467
 range, 416, 467
 x -intercept, 416, 467
- Logistic function, 455
- LORAN, 858
- Loudness of sound, 428

- Magnitude of a vector, 697, 698, 706, 728
 Magnitude of an earthquake, 424, 468
 Main diagonal, 764
 Major axis of an ellipse, 843
 Mathematical induction, 940, 982
 Mathematical models, 91, 114, 304, 758, 867.
 See also Regression.
- Matrices, 764, 821
 addition of, 772, 821
 additive identity, 774, 775
 additive inverses of, 774, 775
 augmented, 764, 821
 coefficient, 764, 821
 cofactor, 793
 column, 779
 columns of, 764
 determinant of, 792–795, 823
 dimensions, 764
 elements, 764, 821
 entries, 764, 821
 equal, 772
 and Gauss–Jordan elimination, 767
 and Gaussian elimination, 764
 identity, multiplicative, 785, 822
 inverses of, 786, 822
 invertible, 788
 main diagonal, 764
 minor, 792
 multiplicative inverse, 786, 822
 multiplying, 776, 822
 by a scalar, 775
 nonsingular, 788
 opposite of, 774
 order, 764
 reduced row-echelon form, 767
 row, 779
 row-echelon form, 766, 767, 821
 row-equivalent, 764
 row-equivalent operations, 765, 821
 rows of, 764
 and scalar multiplication, 774, 822
 singular, 788
 square, 764
 subtraction, 772
 and systems of equations, 754, 764, 767,
 789, 820, 822
 zero, 774
- Matrix. *See* Matrices
 Matrix equation, 789
 Maximum
 linear programming, 806, 824
 quadratic function, 258, 287
 relative, 159, 160, 220
- MAXIMUM feature, 160
 Mean, arithmetic, 928
 Midpoint formula, 68, 144
 Mil, 535
 Minimum
 linear programming, 806, 824
 quadratic function, 258, 287
 relative, 159, 160, 220
- MINIMUM feature, 160
 Minor, 792
 Minor axis of an ellipse, 843
 Models, mathematical, 91, 114, 304, 758, 867.
 See also Regression.
- Monomial, 18
 Mortgage payment formula, 55
 Motion, projectile, 263
 Motion formula, 127
 Multiple, scalar, 707
- Multiplication
 associative property, 5, 53, 779
 commutative property, 5, 53
 of complex numbers, 236, 285,
 677, 723
 of exponential expressions, 10, 53
 of exponents, 10, 53
 of functions, 172, 221
 of matrices, 776, 822
 and scalars, 774, 822
 of ordinates, 562
 of polynomials, 19–21, 53
 of radical expressions, 46, 53
 of rational expressions, 37
 scalar
 for matrices, 774
 for vectors, 707, 710, 728
- Multiplication principle
 for equations, 31, 53, 121, 148
 for inequalities, 139, 149
- Multiplicative identity
 matrices, 785, 822
 real numbers, 5, 53
- Multiplicative inverse
 matrices, 786, 822
 real numbers, 5, 53
- Multiplicity of zeros, 303, 373
- n th partial sum, 915, 981
 n th root, 45
 n th roots of unity, 681
 n th term
 arithmetic sequence, 921, 981
 geometric sequence, 930, 982
- Nanometer, 15
 Nappes of a cone, 832
 Natural logarithms, 419, 468
 Natural numbers, 2
 Nautical mile, 604, 638
 Negative exponents, 9
 Negative rotation, 504
 Newton's law of cooling, 463
 Nondistinguishable objects, permutations of,
 954, 983
- Nonlinear function, 92
 Nonlinear systems of equations, 861, 901
 Nonlinear systems of inequalities,
 867, 901
- Nonnegative root, 45
 Nonpolynomial functions, 298
 Nonreal zeros, 331, 376
- Nonsingular matrix, 788
- Notation
 binomial coefficient, 958, 983
 combination, 957
 decimal, 2
 exponential, 9
 factorial, 949, 982
 function, 79
 interval, 3
 inverse function, 390, 465
 trigonometric, 616
 for matrices, 772
 permutation, 949, 981
 polar, 674
 radical, 45
 scientific, 11
 set, 4, 37
 sigma, 916
 standard, for complex numbers, 675
 summation, 916
 trigonometric, for complex numbers,
 674, 722
- Number line, 3
 distance between points, 6
- Numbers
 complex, 235, 236, 285
 imaginary, 235
 integers, 2
 irrational, 2
 natural, 2
 pure imaginary, 235
 rational, 2
 real, 2
 whole, 2
- Numerator, rationalizing, 48
- Objective function, 806
 Oblique asymptotes, 348, 349, 378
 Oblique triangle, 650
 Obtuse angle, 505
 Odd functions, 193, 223
 Odd multiplicity, 303, 373
 Odd roots, 46, 53
 One-to-one functions, 390, 465
 and inverses, 391, 465
- Open interval, 3, 4
- Operations
 order of, 12
 row-equivalent, 794
- Opposite of a matrix, 774
- Order
 descending, 17
 of a matrix, 764
 of operations, 12
 of real numbers, 3
- Ordered pair, 61
 Ordered triple, 754
 Ordinate, 61
- Ordinates
 addition of, 562
 multiplication of, 563

- Origin, 61
 symmetry with respect to, 190, 191, 223
- Orthogonal vectors, 719
- Oscillation, damped, 563
- Oscilloscope, 562
- Outcomes, 974
 equally likely, 975
- Output, 79
- Pair, ordered, 61
- Parabola, 257, 287, 832
 axis of symmetry, 257, 287, 832
 directrix, 832
 equations, 833, 835, 898
 focus, 832
 graphs, 257, 258, 287, 833, 835, 898
 vertex, 257, 261, 287, 832
- Parallel lines, 111, 113, 147
- Parallelogram law, 699
- Parameter, 892, 904
- Parametric equations, 892, 904
 converting to/from rectangular equations,
 892–894
- Parsec, 15
- Partial fractions, 813
- Partial sum, 915, 981
- Pascal's triangle, 964
- Perimeter, 129
- Periodic function, 543, 544, 555, 559, 576, 578
- Permutations, 948
 of n objects, k at a time, 951, 983
 allowing repetition, 953, 983
 of n objects, total number, 949, 982
 of nondistinguishable objects, 954, 983
- Perpendicular lines, 111, 112, 113, 148
- pH, 427
- Phase shift, 558, 578
- Pi (π), 3
- Piecewise-defined function, 163, 221
- Plane curve, 891, 892, 904
- Plotting a point, 61, 686, 724
- Point
 coordinates of, 61
 plotting, 61, 686, 724
- Point-slope equation, 110, 113, 147
- Poker hands, 963, 979
- Polar axis, 686
- Polar coordinates, 686
 converting to/from rectangular coordinates,
 687, 724, 725
- Polar equation
 of a conic, 887, 890, 902
 converting to a rectangular equation, 689,
 725, 889, 903
 graphing, 690, 724
- Polar notation, 674
- Pole, 686
- Polygon, number of diagonals, 370
- Polynomial function, 296, 372. *See also*
 Polynomials.
 coefficients, 296, 372
- degree, 296, 372
- domain, 298
- factoring, 324, 330, 376
- graph of, 297, 298, 309–316, 373
- intermediate value theorem, 315, 374
- leading coefficient, 296, 372
- leading term, 296, 372
- leading-term test, 300, 372
- as models, 304
- values, 322, 375
- zeros of, 301–304, 330–337, 373,
 376, 377
- Polynomial inequalities, 360, 380
- Polynomials. *See also* Polynomial function.
 addition, 18, 19
- binomial, 18
- coefficients, 17
- constant term, 17
- degree of, 17, 18
- degree of a term, 18
- descending order, 17
- division of, 320–324, 375
- factoring, 22–29
- factors of, 320, 324, 376
- leading coefficient, 17
- monomial, 18
- multiplication of, 19–21, 53
- in one variable, 17
- prime, 29
- in several variables, 18
- subtraction of, 18, 19
- term of, 17
- trinomial, 18
- PolySmlt, 768
- Population growth, 450, 470
 limited, 454
- Position vector, 705
- Positive rotation, 504
- Power, raising to a power, 10, 53
- Power rule
 for exponents, 10, 53
 for logarithms, 431, 468
- Powers
 of complex numbers, 679, 723
 of i , 237
 principle of, 275, 289
- Present value, 464
- Prime polynomial, 29
- Principal root, 45
- Principles(s)
 addition, 31, 53, 122, 139, 148, 149
 fundamental counting, 948, 982
 of mathematical induction, 940, 982
 multiplication, 31, 53, 122, 139, 148, 149
 P (experimental probability), 973, 984
 P (theoretical probability), 975, 984
 of powers, 275, 289
 of square roots, 31, 53, 241, 286
 of zero products, 31, 53, 241, 286
- Probability, 971
 experimental, 972, 973, 984
 properties, 976
 theoretical, 972, 974, 975, 984
- Problem-solving steps, 125
- Product. *See also* Multiplication.
 dot, 714, 728
 of functions, 172, 221
 logarithm of, 430, 468
 of matrices, 776, 822
 raised to a power, 10, 53
 scalar
 for matrices, 774
 for vectors, 707, 710, 728
 of vectors, 714, 728
- Product rule
 for exponents, 10, 53
 for logarithms, 430, 468
- Product-to-sum identities, 609, 642
- Profit, total, 269
- Programming, linear, 806
- Progressions. *See* Sequences
- Projectile motion, 263
- Properties
 of addition of real numbers, 5, 53
 associative, 5, 53, 779
 base-exponent, 439, 469
 commutative, 5, 53, 775
 of cosine function, 545
 distributive, 5, 53, 779
 of exponential functions, 403
 of exponents, 10, 53
 of logarithmic equality, 440, 469
 of logarithmic functions, 416, 467
 of logarithms, 430–433, 436, 468
 of matrix addition, 775
 of matrix multiplication, 779
 of multiplication of real numbers,
 5, 53
 of probability, 976
 of radicals, 46, 53
 of real numbers, 5, 53
 of scalar multiplication
 for matrices, 775
 for vectors, 710
 of sine function, 545
 of vector addition, 710
- Proportional. *See* Variation
- Proving trigonometric identities,
 606, 641
- Pure imaginary numbers, 235
- Pythagorean equation, 481
- Pythagorean identities, 584–586, 639
- Pythagorean theorem, 48, 53
- Quadrantal angle, 510, 572
- Quadrants, 61
- Quadratic equations, 31, 241, 286.
See also Quadratic function.
 discriminant, 248, 287
 solving, 31, 53, 241, 286
 standard form, 241
- Quadratic form, equation in, 249, 287

- Quadratic formula, 247, 287
- Quadratic function, 241, 286, 296, 297.
 - See also Quadratic equations.
 - applications, 262
 - graph, 257, 262, 287. See also Parabola.
 - maximum value, 258, 287
 - minimum value, 258, 287
 - zeros of, 243
- Quadratic inequalities, 360, 380
- Quadratic regression, 759
- Quartic function, 296
- Quotient
 - difference, 175, 222
 - of functions, 172, 222
 - logarithm of, 432, 468
 - of polynomials, 320, 321
 - raised to a power, 10, 53
- Quotient rule
 - for exponents, 10, 53
 - for logarithms, 432, 468
- Radian measure, 523, 528, 574, 575
 - converting to degree measure, 525, 574
- Radical, 45. See also Radical expressions.
- Radical equation, 274, 289
- Radical expressions, 45. See also Roots.
 - addition, 47
 - conjugate, 49
 - converting to exponential notation, 49, 53
 - division, 46, 53
 - multiplication, 46, 53
 - properties of, 46, 53
 - rationalizing denominators or numerators, 48
 - simplifying, 46
 - subtraction, 47
- Radicand, 45
- Radius, 69, 145, 840
- Raising a power to a power, 10, 53
- Raising a product or quotient to a power, 10, 53
- Range
 - of a function, 76, 83, 145
 - of a relation, 78
- Rate of change, 93, 98, 146, 175
- Ratio, common, 929, 982
- Rational equations, 272, 288
- Rational exponents, 49, 53
- Rational expressions, 36
 - addition, 39
 - complex, 41
 - decomposing, 793
 - division, 37
 - domain, 36
 - multiplication, 37
 - simplifying, 37
 - subtraction, 39
- Rational function, 340, 378
 - asymptotes, 342–349, 378
 - domain, 341
 - graph of, 340, 350, 378
- Rational inequalities, 365, 381
- Rational numbers, 2
- Rational zeros theorem, 333, 377
- Rationalizing denominators or numerators, 48
- Real axis, 673
- Real numbers, 2, 3
 - order, 3
 - properties, 5, 53
- Real part, 235, 285
- Reciprocal, in division, 38
- Reciprocal function, 194
 - trigonometric, 479, 569
- Rectangular coordinates, converting to/from
 - polar coordinates, 687, 724, 725
- Rectangular equations
 - converting to/from parametric equations, 892–894
 - converting to/from polar equations, 689, 725, 889, 903
- Recursion formula, 917, 981
- Recursively defined sequence, 917, 981
- Reduced row-echelon form, 767
- Reducible to quadratic equation, 249, 287
- Reference angle, 512, 572
- Reference triangle, 506
- Reflection, 190, 198, 199, 204, 224
 - and inverse relations and functions, 388, 394
 - on unit circle, 537, 576
- Regression
 - correlation coefficient, 117
 - linear, 116, 117
 - quadratic, 759
- Related equation, 360, 800
- Relation, 78
 - domain, 78
 - inverse, 388, 465
 - range, 78
- Relative maxima and minima, 159, 160, 220
- Remainder, 320, 321
- Remainder theorem, 322, 375
- Repeating decimals, 2
 - changing to fraction notation, 934
- Representing a vector, 701, 727
- Resolving a vector into its components, 701, 727
- Restricting a domain, 396
- Resultant, 699, 727
- Revenue, total, 269
- Richter scale, 424, 468
- Right angle, 478, 505
- Right triangle, 478
 - solving, 490
- Rise, 93, 146
- Roots. See also Radical expressions.
 - of complex numbers, 680, 724
 - cube, 45
 - of equations, 241
 - even, 46, 53
 - n th, 45
 - nonnegative, 45
 - odd, 46, 53
 - principal, 45
 - square, 45
- Rotation of a ray, 504
- Rotation of axes, 875–880, 902
- Row-echelon form, 766, 767, 821
- Row-equivalent matrices, 764
- Row-equivalent operations, 765, 821
- Row matrix, 779
- Rows of a matrix, 764
- Run, 93, 146
- Salvage value, 106, 929
- Sample space, 975
- Savings plan, 16
- Scalar, 705, 707, 774, 822
- Scalar components of a vector, 705, 728
- Scalar multiplication
 - for matrices, 774, 822
 - for vectors, 707, 710, 728
- Scalar product
 - for matrices, 774, 822
 - for vectors, 707, 710, 728
- Scatterplot, 114
- Scientific notation, 11
- Secant function, 479, 507, 537, 548, 569
 - graph, 548
- Secant line, 175
- Second coordinate, 61
- Semiperimeter, 672
- Sequences, 912
 - alternating, 913
 - arithmetic, 920, 982
 - Fibonacci, 919
 - finite, 912, 981
 - general term, 913, 914
 - geometric, 929, 982
 - graph, 914
 - infinite, 912, 981
 - partial sum, 915, 981
 - recursive definition, 917, 981
 - of statements, 940
 - terms, 913
- Series
 - arithmetic, 923
 - finite, 915, 981
 - geometric, 931
 - infinite, 915, 981
 - partial sum, 915, 981
- Set-builder notation, 37
- Sets
 - element of, 3
 - empty, 282
 - notation, 4, 37
 - solution, 31, 121, 138, 800
 - subsets, 3, 960
 - union of, 141
- Shift of a function. See Translation of a function

- Shrinkings, 200, 201, 204, 225, 555, 559, 577, 578
- Sigma notation, 916
- Signs of trigonometric functions, 508, 571
- Similar terms, 18
- Similar triangles, 480
- Simple-interest formula, 128
- Simplifying radical expressions, 46
- Simplifying rational expressions, 37
complex, 41
- Simplifying trigonometric expressions, 586
- Sine function, 478, 479, 507, 537, 569
amplitude, 544, 545
domain, 543, 545
graph, 541, 545
period, 544, 545
range, 543, 545
- Sines, law of, 652, 720
- Singular matrix, 788
- Slant asymptote, 348, 349, 378
- Slope, 93, 113, 146
applications, 96
of horizontal lines, 95, 146
as rate of change, 93, 98, 146
of vertical lines, 95, 146
- Slope-intercept equation, 100, 109, 113, 146, 147
- Solution set, 31, 121, 138, 800
- Solutions
of equations, 61, 121
feasible, 806, 824
of inequalities, 138, 800
of systems of equations, 738, 819
- Solving equations, 31, 53, 122, 123, 148, 241, 272, 274, 280, 286, 289, 439, 625, 644.
See also Solving systems of equations.
- Solving formulas, 33
- Solving inequalities, 138–141, 282, 289, 360–368, 381
systems of, 804, 823, 867, 901
- Solving systems of equations
with Cramer's rule, 796, 797
elimination method, 740, 820
Gauss–Jordan elimination, 767
Gaussian elimination, 754, 764, 820
graphically, 738
with the inverse of a matrix, 779, 822
nonlinear, 861, 901
substitution method, 739, 820
- Solving triangles, 490, 570, 650, 653, 655, 677, 720, 721, 722
oblique, 650, 653, 655, 664, 667, 720, 771, 772
right, 490, 570
- Sound, loudness, 428
- Speed
angular, 529, 575
linear, 529, 575
- Square, completing, 244, 286
- Square matrix, 764
determinant, 792
- Square root, 45
- Square root function, 194
- Square roots, principle of, 31, 53, 241, 286
- Squares, differences of, 27
- Squares of binomials, 20, 53
factoring, 28, 53
- Squaring function, 194
- Squaring the window, 70
- Standard form
for equation of a circle, 69, 145, 840, 898
for equation of an ellipse, 843, 845, 899
for equation of a hyperbola, 852, 855, 900
for equation of a parabola, 833, 835, 898
for quadratic equation, 241
- Standard notation, complex numbers, 675
- Standard position
for an angle, 504
for a vector, 705
- Standard viewing window, 64
- State the answer, 125
- Straight angle, 505
- Straight-line depreciation, 106
- Stretchings, 200, 201, 204, 225, 555, 559, 577, 578
- Study tips, 95, 160, 174, 190, 246, 277, 315, 321, 337, 415, 436, 452, 480, 531, 586, 606, 615, 634, 653, 669, 674, 747, 766, 816, 835, 844, 853, 867, 877, 896, 921, 950, 972
- Subsets, 3, 960
total number, 969, 984
- Substitution method, 739, 820
- Subtraction. *See also* Difference.
of complex numbers, 236, 285
of exponents, 10, 53
of functions, 172, 221
of matrices, 772
of polynomials, 18, 19
of radical expressions, 47
of rational expressions, 39
of vectors, 709, 728
- Sum and difference, product of, 20, 53
- Sum and difference identities, 589–593, 639
- Sum-to-product identities, 610, 642
- Summation, index of, 916
- Summation notation, 916
- Sums. *See also* Addition.
of arithmetic sequences, 923, 981
of cubes, factoring, 28, 53
of functions, 172, 221
of geometric sequences, 931, 933, 982
graphs of, 562
of logarithms, 430, 436, 468
partial, 915, 981
squares of, 20, 53
of vectors, 699, 708, 710, 727, 728
- Supplementary angles, 506, 571
- Supply and demand, 747
- Symmetry, 189
axis of, 257, 287
with respect to the origin, 190, 191, 223
with respect to the x -axis, 190, 191, 223
with respect to the y -axis, 190, 191, 223
tests for, 191, 223
- Synthetic division, 322, 375
- Systems of equations, 738, 819
consistent, 739, 819
in decomposing rational expressions, 816
dependent equations, 739, 819
equivalent, 742
inconsistent, 739, 819
independent equations, 739, 819
in matrix form, 789
nonlinear, 861, 901
and partial fractions, 816
solutions, 738, 819
solving. *See* Solving systems of equations
in three variables, 754, 820
in two variables, 738, 819
- Systems of inequalities, 804, 823, 867, 901
- TABLE feature, 65, 124
- Tangent function, 479, 507, 547, 548, 569, 577
- Term, leading, 296, 372
- Terminal point of a vector, 698
- Terminal side of an angle, 504
- Terminating decimal, 2
- Terms of a polynomial, 17
constant, 17
degree of, 18
leading, 296, 372
like (similar), 18
- Terms of a sequence, 913
- TEST menu, 140
- Theorem
binomial, 966, 967, 983
DeMoivre's, 679, 723
factor, 324, 376
fundamental, of algebra, 330, 376
intermediate value, 315, 374
Pythagorean, 48, 53
rational zeros, 333, 377
remainder, 322, 375
- Theoretical probability, 972, 974, 975, 978
- Time of a free fall, 250
- Total cost, profit, revenue, 269
- Tower of Hanoi problem, 954
- Trade-in value, 106
- Transformations of functions, 194–204, 224–226, 551–561, 577
- Translate to an equation, 125
- Translation of a function, 195–197, 204, 224, 551, 556, 557, 559, 578
- Transverse axis of a hyperbola, 851
- Tree diagram, 947
- Triangle, Pascal's, 964
- Triangles
area, 658, 659, 721
isosceles, 482

- oblique, 650
- reference, 506
- right, 478
- semiperimeter, 672
- similar, 480
- solving, 490, 570, 650, 653, 655, 664, 667, 720, 721, 722
- Trigonometric equations, 625, 644
- Trigonometric expressions, simplifying, 586
- Trigonometric functions
 - of acute angles, 478, 479, 484, 569
 - of any angle, 507, 514, 571, 572
 - circular, 536, 537, 576
 - cofunctions, 486, 487, 570, 597, 598, 640
 - composition, 620, 643
 - domain, 536, 543, 545, 575
 - graphs, 541, 547, 548, 551–561, 577
 - inverse, 616, 619, 642
 - of quadrantal angles, 510, 572
 - range, 536, 619
 - reciprocal, 479, 569
 - signs of, 508, 571
 - value of 30° , 60° , 45° , 481–483, 569
- Trigonometric identities, 487, 570, 584–586, 589–593, 597–602, 609, 610, 639–642
 - proving, 606, 641
- Trigonometric notation for complex numbers, 674, 722
- Trinomial, 18
 - factoring, 23–27
- Triple, ordered, 444
- Turning point, 309, 373

- Undefined slope, 95, 146
- Union of sets, 141
- Unit circle, 75, 520
 - reflections on, 537, 576
- Unit vector, 711, 729
- Unity, n th roots of, 681

- VALUE feature, 80
- Values, critical, 365
- Values, function, 79, 80, 305
- Variable, 64
- Variable costs, 106
- Variation
 - combined, 215, 227
 - direct, 211, 226
 - inverse, 213, 226
 - joint, 215, 227
- Variation constant, 211, 213, 226
- Variations in sign, 335
- Vectors, 697, 726
 - addition of, 699, 708, 710, 727, 728
 - additive identity, 710, 729
 - angle between, 715, 730
 - component form, 706, 727
 - components, 701, 727
 - scalar, 705, 728
 - direction, 697
 - direction angle, 712, 729
 - dot product, 714, 728
 - equivalent, 697, 707, 726, 728
 - and forces in equilibrium, 715, 730
 - initial point, 698
 - length, 697, 698, 706, 728
 - as linear combinations of unit vectors, 711, 729
 - magnitude, 697, 698, 706, 728
 - orthogonal, 719
 - position, 705
 - representing, 701, 727
 - resolving into components, 701, 727
 - resultant, 699, 727
 - scalar multiplication, 707, 710, 728
 - standard position, 705
 - subtraction, 709, 728
 - sum of, 699, 708, 710, 727, 728
 - terminal point, 698
 - unit, 711, 729
 - zero, 710, 729
- Velocity, 697
- Vertex
 - of an angle, 504
 - of an ellipse, 843
 - of a hyperbola, 851
 - of a parabola, 257, 261, 287, 832
- Vertical asymptotes, 342–345, 378
- Vertical component of a vector, 701, 727
 - scalar, 705, 728
- Vertical line, 92, 113, 146
 - slope, 95, 146
- Vertical-line test, 81, 145
- Vertical stretching and shrinking, 200, 204, 225, 553, 559, 578

- Vertical translation, 195, 204, 224, 551, 556, 557, 559, 578
- Vertices. *See* Vertex
- Viewing window, 64
 - squaring, 70
 - standard, 64
- Visualizing the Graph, 71, 102, 205, 266, 317, 356, 425, 489, 565, 635, 694, 869, 936

- Walking speed, 423
- Wedge bevel, 668
- Whispering gallery, 847
- Whole numbers, 2
- Window, 64
 - squaring, 70
 - standard, 64

- x -axis, 61
 - symmetry with respect to, 190, 191, 223
- x -coordinate, 61
- x -intercept, 62, 144
 - ellipse, 843
 - logarithmic function, 416, 467
- xy -term, eliminating, 879, 902

- y -axis, 61
 - symmetry with respect to, 190, 191, 223
- y -coordinate, 61
- y -intercept, 62, 99, 144
 - ellipse, 843
 - exponential function, 403, 466

- Zero, exponent, 9
- ZERO feature, 132
- Zero matrix, 774
- Zero method, 132, 133
- Zero of a function. *See* Zeros of functions
- Zero products, principle of, 31, 53, 241, 286
- Zero slope, 95, 146
- Zero vector, 710, 729
- Zeros of functions, 130, 131, 149, 243, 301–304, 330–337, 373, 376, 377
 - irrational, 332, 376
 - multiplicity, 303, 373
 - nonreal, 331, 376
 - rational, 333, 377
- ZOOM menu, 64, 70

Geometry

Plane Geometry

Rectangle

Area: $A = lw$

Perimeter: $P = 2l + 2w$

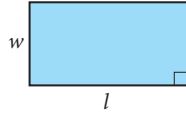

Square

Area: $A = s^2$

Perimeter: $P = 4s$

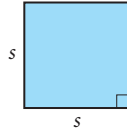

Triangle

Area: $A = \frac{1}{2}bh$

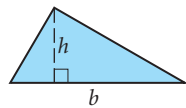

Sum of Angle Measures

$A + B + C = 180^\circ$

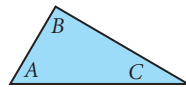

Right Triangle

Pythagorean theorem

(equation):

$$a^2 + b^2 = c^2$$

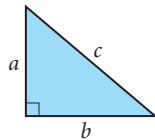

Parallelogram

Area: $A = bh$

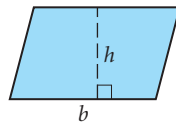

Trapezoid

Area: $A = \frac{1}{2}h(a + b)$

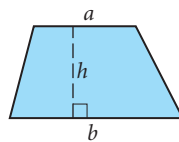

Circle

Area: $A = \pi r^2$

Circumference:

$$C = \pi d = 2\pi r$$

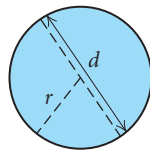

Solid Geometry

Rectangular Solid

Volume: $V = lwh$

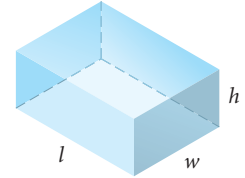

Cube

Volume: $V = s^3$

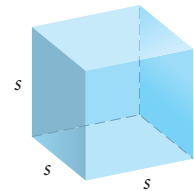

Right Circular Cylinder

Volume: $V = \pi r^2 h$

Lateral surface area:

$$L = 2\pi r h$$

Total surface area:

$$S = 2\pi r h + 2\pi r^2$$

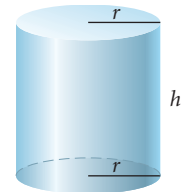

Right Circular Cone

Volume: $V = \frac{1}{3}\pi r^2 h$

Lateral surface area:

$$L = \pi r s$$

Total surface area:

$$S = \pi r^2 + \pi r s$$

Slant height:

$$s = \sqrt{r^2 + h^2}$$

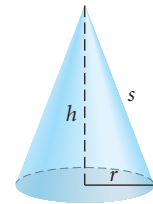

Sphere

Volume: $V = \frac{4}{3}\pi r^3$

Surface area: $S = 4\pi r^2$

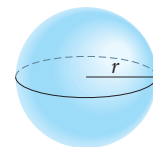

Algebra

Properties of Real Numbers

Commutative:	$a + b = b + a; ab = ba$
Associative:	$a + (b + c) = (a + b) + c;$ $a(bc) = (ab)c$
Additive Identity:	$a + 0 = 0 + a = a$
Additive Inverse:	$-a + a = a + (-a) = 0$
Multiplicative Identity:	$a \cdot 1 = 1 \cdot a = a$
Multiplicative Inverse:	$a \cdot \frac{1}{a} = \frac{1}{a} \cdot a = 1, a \neq 0$
Distributive:	$a(b + c) = ab + ac$

Exponents and Radicals

$$a^m \cdot a^n = a^{m+n} \qquad \frac{a^m}{a^n} = a^{m-n}$$
$$(a^m)^n = a^{mn} \qquad (ab)^m = a^m b^m$$
$$\left(\frac{a}{b}\right)^m = \frac{a^m}{b^m} \qquad a^{-n} = \frac{1}{a^n}$$

If n is even, $\sqrt[n]{a^n} = |a|$.

If n is odd, $\sqrt[n]{a^n} = a$.

$$\sqrt[n]{a} \cdot \sqrt[n]{b} = \sqrt[n]{ab}, a, b \geq 0$$

$$\sqrt[n]{\frac{a}{b}} = \frac{\sqrt[n]{a}}{\sqrt[n]{b}}$$

$$\sqrt[n]{a^m} = (\sqrt[n]{a})^m = a^{m/n}$$

Special-Product Formulas

$$(a + b)(a - b) = a^2 - b^2$$

$$(a + b)^2 = a^2 + 2ab + b^2$$

$$(a - b)^2 = a^2 - 2ab + b^2$$

$$(a + b)^3 = a^3 + 3a^2b + 3ab^2 + b^3$$

$$(a - b)^3 = a^3 - 3a^2b + 3ab^2 - b^3$$

$$(a + b)^n = \sum_{k=0}^n \binom{n}{k} a^{n-k} b^k, \text{ where}$$

$$\binom{n}{k} = \frac{n!}{k!(n-k)!}$$
$$= \frac{n(n-1)(n-2) \cdots [n-(k-1)]}{k!}$$

Factoring Formulas

$$a^2 - b^2 = (a + b)(a - b)$$

$$a^2 + 2ab + b^2 = (a + b)^2$$

$$a^2 - 2ab + b^2 = (a - b)^2$$

$$a^3 + b^3 = (a + b)(a^2 - ab + b^2)$$

$$a^3 - b^3 = (a - b)(a^2 + ab + b^2)$$

Interval Notation

$$(a, b) = \{x \mid a < x < b\}$$

$$[a, b] = \{x \mid a \leq x \leq b\}$$

$$(a, b] = \{x \mid a < x \leq b\}$$

$$[a, b) = \{x \mid a \leq x < b\}$$

$$(-\infty, a) = \{x \mid x < a\}$$

$$(a, \infty) = \{x \mid x > a\}$$

$$(-\infty, a] = \{x \mid x \leq a\}$$

$$[a, \infty) = \{x \mid x \geq a\}$$

Absolute Value

$$|a| \geq 0$$

For $a > 0$,

$$|X| = a \rightarrow X = -a \text{ or } X = a,$$

$$|X| < a \rightarrow -a < X < a,$$

$$|X| > a \rightarrow X < -a \text{ or } X > a.$$

Equation-Solving Principles

$$a = b \rightarrow a + c = b + c$$

$$a = b \rightarrow ac = bc$$

$$a = b \rightarrow a^n = b^n$$

$$ab = 0 \leftrightarrow a = 0 \text{ or } b = 0$$

$$x^2 = k \rightarrow x = \sqrt{k} \text{ or } x = -\sqrt{k}$$

Inequality-Solving Principles

$$a < b \rightarrow a + c < b + c$$

$$a < b \text{ and } c > 0 \rightarrow ac < bc$$

$$a < b \text{ and } c < 0 \rightarrow ac > bc$$

(Algebra continued)

Algebra (continued)

The Distance Formula

The distance from (x_1, y_1) to (x_2, y_2) is given by

$$d = \sqrt{(x_2 - x_1)^2 + (y_2 - y_1)^2}.$$

The Midpoint Formula

The midpoint of the line segment from (x_1, y_1) to (x_2, y_2) is given by

$$\left(\frac{x_1 + x_2}{2}, \frac{y_1 + y_2}{2} \right).$$

Formulas Involving Lines

The slope of the line containing points (x_1, y_1) and (x_2, y_2) is given by

$$m = \frac{y_2 - y_1}{x_2 - x_1}.$$

Slope–intercept equation: $y = f(x) = mx + b$

Horizontal line: $y = b$ or $f(x) = b$

Vertical line: $x = a$

Point–slope equation: $y - y_1 = m(x - x_1)$

The Quadratic Formula

The solutions of $ax^2 + bx + c = 0, a \neq 0$, are given by

$$x = \frac{-b \pm \sqrt{b^2 - 4ac}}{2a}.$$

Compound Interest Formulas

Compounded n times per year: $A = P \left(1 + \frac{i}{n} \right)^{nt}$

Compounded continuously: $P(t) = P_0 e^{kt}$

Properties of Exponential and Logarithmic Functions

$$\log_a x = y \leftrightarrow x = a^y \qquad a^x = a^y \leftrightarrow x = y$$
$$\log_a MN = \log_a M + \log_a N \qquad \log_a M^p = p \log_a M$$

$$\log_a \frac{M}{N} = \log_a M - \log_a N$$

$$\log_b M = \frac{\log_a M}{\log_a b}$$

$$\log_a a = 1 \qquad \log_a 1 = 0$$
$$\log_a a^x = x \qquad a^{\log_a x} = x$$

Conic Sections

Circle: $(x - h)^2 + (y - k)^2 = r^2$

Ellipse: $\frac{(x - h)^2}{a^2} + \frac{(y - k)^2}{b^2} = 1,$

$$\frac{(x - h)^2}{b^2} + \frac{(y - k)^2}{a^2} = 1$$

Parabola: $(x - h)^2 = 4p(y - k),$
 $(y - k)^2 = 4p(x - h)$

Hyperbola: $\frac{(x - h)^2}{a^2} - \frac{(y - k)^2}{b^2} = 1,$

$$\frac{(y - k)^2}{a^2} - \frac{(x - h)^2}{b^2} = 1$$

Arithmetic Sequences and Series

$$a_1, a_1 + d, a_1 + 2d, a_1 + 3d, \dots$$

$$a_{n+1} = a_n + d \qquad a_n = a_1 + (n - 1)d$$

$$S_n = \frac{n}{2}(a_1 + a_n)$$

Geometric Sequences and Series

$$a_1, a_1 r, a_1 r^2, a_1 r^3, \dots$$

$$a_{n+1} = a_n r \qquad a_n = a_1 r^{n-1}$$

$$S_n = \frac{a_1(1 - r^n)}{1 - r} \qquad S_\infty = \frac{a_1}{1 - r}, |r| < 1$$

Trigonometry

Trigonometric Functions

Acute Angles

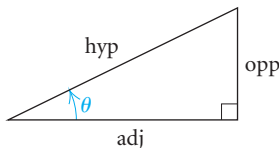

$$\begin{aligned}\sin \theta &= \frac{\text{opp}}{\text{hyp}}, & \csc \theta &= \frac{\text{hyp}}{\text{opp}}, \\ \cos \theta &= \frac{\text{adj}}{\text{hyp}}, & \sec \theta &= \frac{\text{hyp}}{\text{adj}}, \\ \tan \theta &= \frac{\text{opp}}{\text{adj}}, & \cot \theta &= \frac{\text{adj}}{\text{opp}}\end{aligned}$$

Any Angle

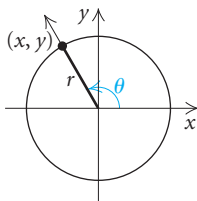

$$\begin{aligned}\sin \theta &= \frac{y}{r}, & \csc \theta &= \frac{r}{y}, \\ \cos \theta &= \frac{x}{r}, & \sec \theta &= \frac{r}{x}, \\ \tan \theta &= \frac{y}{x}, & \cot \theta &= \frac{x}{y}\end{aligned}$$

Real Numbers

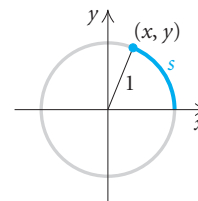

$$\begin{aligned}\sin s &= y, & \csc s &= \frac{1}{y}, \\ \cos s &= x, & \sec s &= \frac{1}{x}, \\ \tan s &= \frac{y}{x}, & \cot s &= \frac{x}{y}\end{aligned}$$

Basic Trigonometric Identities

$$\begin{aligned}\sin(-x) &= -\sin x, \\ \cos(-x) &= \cos x, \\ \tan(-x) &= -\tan x,\end{aligned}$$

$$\begin{aligned}\tan x &= \frac{\sin x}{\cos x}, \\ \cot x &= \frac{\cos x}{\sin x},\end{aligned}$$

$$\begin{aligned}\csc x &= \frac{1}{\sin x}, \\ \sec x &= \frac{1}{\cos x}, \\ \cot x &= \frac{1}{\tan x}\end{aligned}$$

Pythagorean Identities

$$\begin{aligned}\sin^2 x + \cos^2 x &= 1, \\ 1 + \cot^2 x &= \csc^2 x, \\ 1 + \tan^2 x &= \sec^2 x\end{aligned}$$

Identities Involving $\pi/2$

$$\begin{aligned}\sin(\pi/2 - x) &= \cos x, \\ \cos(\pi/2 - x) &= \sin x, & \sin(x \pm \pi/2) &= \pm \cos x, \\ \tan(\pi/2 - x) &= \cot x, & \cos(x \pm \pi/2) &= \mp \sin x\end{aligned}$$

Sum and Difference Identities

$$\begin{aligned}\sin(u \pm v) &= \sin u \cos v \pm \cos u \sin v, \\ \cos(u \pm v) &= \cos u \cos v \mp \sin u \sin v, \\ \tan(u \pm v) &= \frac{\tan u \pm \tan v}{1 \mp \tan u \tan v}\end{aligned}$$

Double-Angle Identities

$$\begin{aligned}\sin 2x &= 2 \sin x \cos x, \\ \cos 2x &= \cos^2 x - \sin^2 x \\ &= 1 - 2 \sin^2 x \\ &= 2 \cos^2 x - 1, \\ \tan 2x &= \frac{2 \tan x}{1 - \tan^2 x}\end{aligned}$$

Half-Angle Identities

$$\begin{aligned}\sin \frac{x}{2} &= \pm \sqrt{\frac{1 - \cos x}{2}}, & \cos \frac{x}{2} &= \pm \sqrt{\frac{1 + \cos x}{2}}, \\ \tan \frac{x}{2} &= \pm \sqrt{\frac{1 - \cos x}{1 + \cos x}} = \frac{\sin x}{1 + \cos x} = \frac{1 - \cos x}{\sin x}\end{aligned}$$

(Trigonometry continued)

Trigonometry (continued)

The Law of Sines

In any $\triangle ABC$,

$$\frac{a}{\sin A} = \frac{b}{\sin B} = \frac{c}{\sin C}$$

The Law of Cosines

In any $\triangle ABC$,

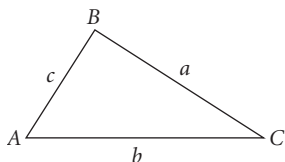

$$a^2 = b^2 + c^2 - 2bc \cos A,$$

$$b^2 = a^2 + c^2 - 2ac \cos B,$$

$$c^2 = a^2 + b^2 - 2ab \cos C.$$

Trigonometric Function Values of Special Angles

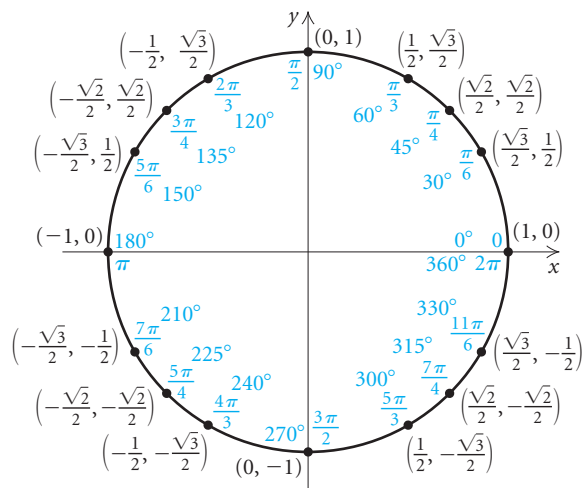

Graphs of Trigonometric Functions

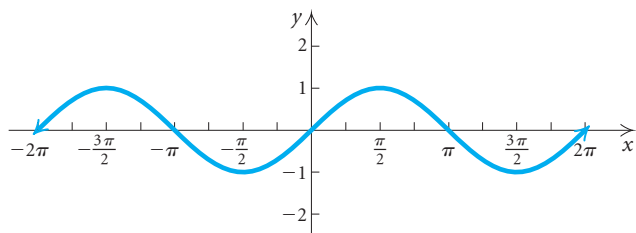

The sine function: $f(x) = \sin x$

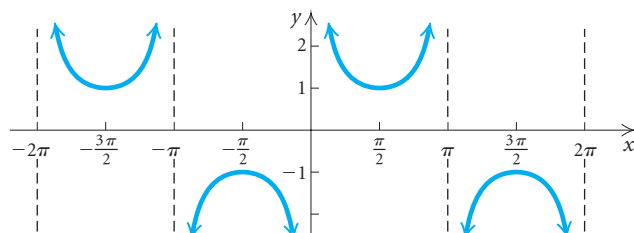

The cosecant function: $f(x) = \csc x$

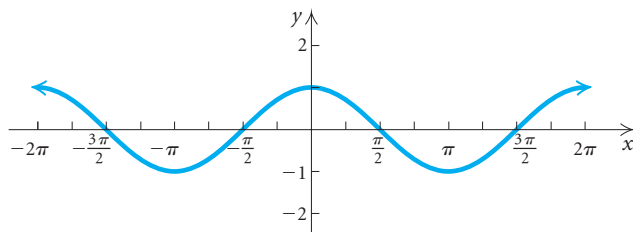

The cosine function: $f(x) = \cos x$

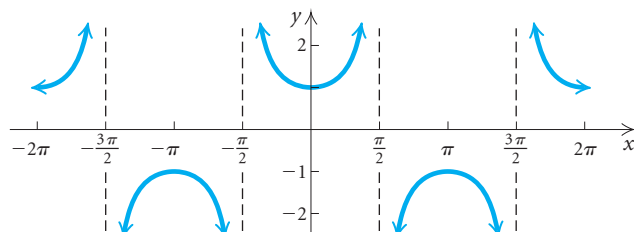

The secant function: $f(x) = \sec x$

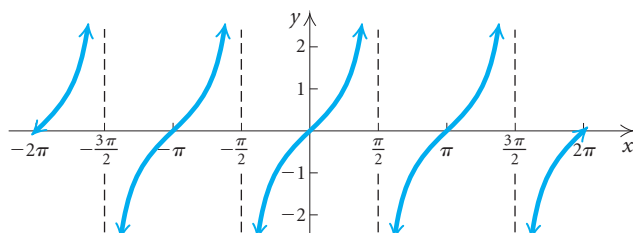

The tangent function: $f(x) = \tan x$

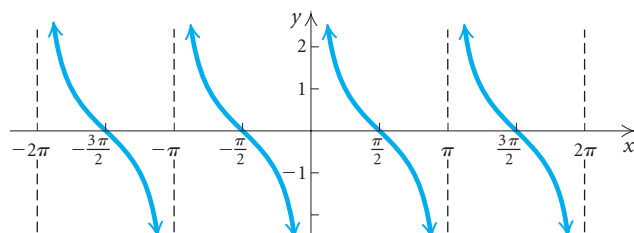

The cotangent function: $f(x) = \cot x$

A Library of Functions

Linear function

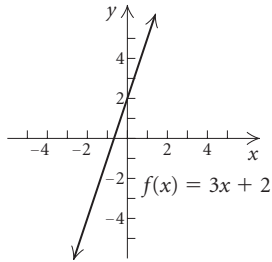

Linear function

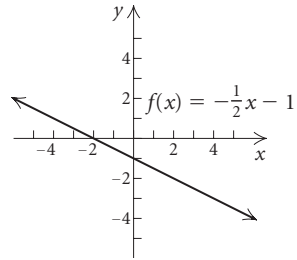

Constant function

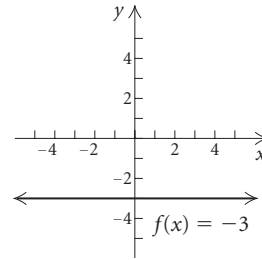

Absolute-value function

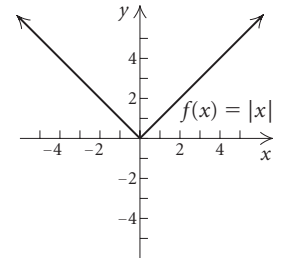

Squaring function

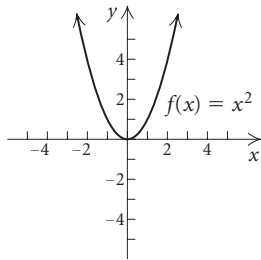

Quadratic function

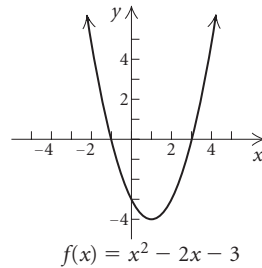

Quadratic function

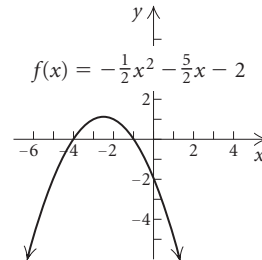

Square-root function

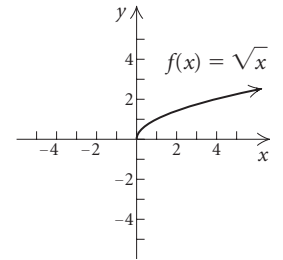

Cubing function

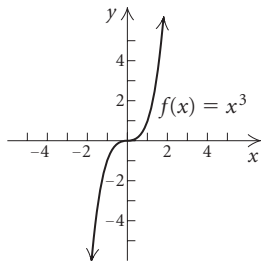

Cube root function

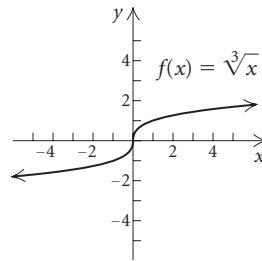

Greatest integer function

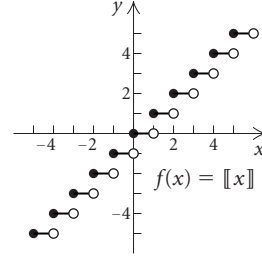

Rational function

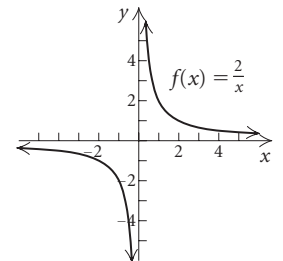

Exponential function

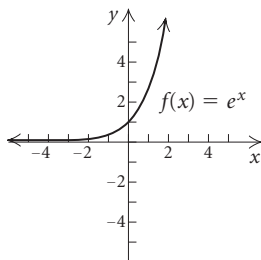

Exponential function

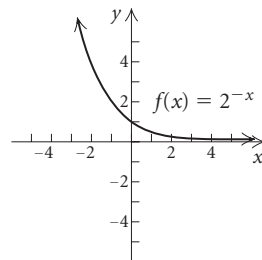

Logarithmic function

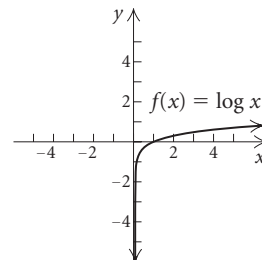

Logistic function

